

Auto Crane Company

P.O. BOX 580697 • TULSA, OKLAHOMA 74158-0697
4707 N. MINGO ROAD • TULSA, OKLAHOMA 74117
918-836-0463 • TELEX 158108 RAMSEY TUL
FAX 918-438-6688

OWNER'S MANUAL

2003 SERIES

SERIAL NO. _____

2003 SERIES - OWNER'S MANUAL

- CONTENTS -

	SECTION/PAGE
1. INTRODUCTION	1-1.0.0
2. MAINTENANCE OF BATTERIES	1-4.0.0
3. INSTALLATION	2-1.0.0
4. OPERATION INSTRUCTIONS	3-1.0.0
5. GENERAL ASSEMBLY	4-1.0.0
6. ACTUATOR ASSEMBLY	4-3.0.0
7. GENERAL DIMENSIONS	4-5.0.0
8. ELECTRICAL SECTION	5-1.0.0
9. TROUBLESHOOTER - ELECTRICAL	5-3.0.0
10. WARRANTY	LAST PAGE

INTRODUCTION --2003 SERIES

Auto Crane products have been engineered to provide safe, trouble-free, dependable service for many years when these products are properly used and maintained.

To assist you in obtaining the best service from your crane and to avoid untimely failure of the unit and/or the vehicle on which it is mounted, the following operating and service instructions are herein published, and it is specifically recommended that all operating and service personnel consider this manual as mandatory material for reading and study before operating or servicing Auto Crane products. It is highly recommended that crane owners, equipment managers and supervisors also read this manual.

Auto Crane has incorporated several safety features in the 2003 series for your protection. The material and electrical systems were designed to minimize weight and lengthen durability. For your convenience the overall dimensions of the 2003 series are included on the Decal & Dimension Drawing. Remember that the crane adds weight to the vehicle and may change the driving and riding characteristics of the vehicle on which it is mounted unless this weight is properly provided for with appropriate overload springs. The payload of the vehicle is also reduced by the amount that the crane weighs, and as the vehicle is loaded, care should be exercised not to overload the vehicle. Exercising care in distributing the payload on the vehicle will greatly improve the driving and riding characteristics of the vehicle.

The 2003 series cranes are attached directly to your 12 volt truck electrical system. The power cable and retaining clips are included with the crane. A typical power cable mounting and hookup is shown. The performance of your new crane depends on the truck electrical system. The use of the low maintenance battery is not recommended for use on any Auto Crane product. The recommended alternator and battery that will give the longest life with the most useful duty cycle is a 50 amp. alternator with a 450 cold cranking rated battery. These specifications should be considered minimum.

It has always been Auto Crane Company policy to handle all warranty claims we receive as promptly as possible. If material or workmanship is involved, immediate corrective action is taken. It is therefore, understandable that Auto Crane Company cannot assume responsibility or liability when our products have obviously been abused, mis-used, overloaded or otherwise damaged by inexperienced persons trying to operate the equipment without even reading the manual. The Auto Crane is designed and built to be safe and efficient. Auto Crane will not assume responsibility or liability for any unit which has been modified, changed, or which has unauthorized or unapproved components installed.

Auto Crane maintains a strong distributor network and a knowledgeable Customer Service Department. In most cases an equipment problem can be solved through a telephone conversation with our Customer Service Department. The Customer Service Department also has the ability to bring a local distributor, a regional sales manager, or a factory serviceman into the solution of an equipment problem if necessary. If through no fault of Auto Crane Company it is necessary to send an experienced factory serviceman on a field service call, the rates stated in the Auto Crane Distributor's Flat Rate manual will apply.

Auto Crane Company's extensive Research and Development Program assures our customers of the best equipment on the market, and our Engineering Staff, as well as our knowledgeable sales people are always available to our customers in solving crane and winch-type application problems. When in doubt-call the the Auto Crane factory.

DISTRIBUTOR ASSISTANCE:

Should you require any assistance not given in this manual, we recommend that you consult your nearest Auto Crane Distributor. Our distributors are stocked with authorized replacement parts and a service department that can solve almost any needed repair.

NOTE: THIS MANUAL SHOULD REMAIN WITH THE CRANE AT ALL TIMES.

The material herein does not imply to cover all maintenance, instructions, operations, or variations pertinent to every possible situation. If additional information is required, please refer to the Auto Crane Company at the following telephone number: 918 - 438-2760. The information contained in the manual was in effect at the time of printing. Auto Crane Company reserves the right to update this material at any time without prior notice or obligation.

Auto Crane Company issues a limited warranty certificate with each unit sold. See last page for warranty policy.

-IMPORTANT-

SAFETY TIPS AND PRECAUTIONS

1. Make certain the vehicle meets minimum chassis requirements. (These requirements do not guarantee unit stability.)
2. Make certain the crane is installed per factory specifications. Contact your local Distributor or the Auto Crane factory if any questions arise.
3. Keep the vehicle in as level a position as possible while loading or unloading.
4. ALWAYS set the vehicle emergency brake before beginning crane operations
5. ALWAYS use outriggers from vehicle to the ground during crane operation. Insure that they are firmly positioned on solid footings.
6. All load ratings are based on crane capacity, NOT unit stability.
7. ALWAYS comply with load chart capacities (centerline of rotation to hoist hook).
8. NEVER OPERATE THE CRANE NEAR ELECTRICAL POWER LINES. Auto Crane Company recommends that a crane never be moved any closer to a power line (including telephone lines) than 20 feet at any point.
9. Keep objects and personnel clear of crane path during operation.
10. Keep hoist cable pulled tight at all times.
11. WARNING NEVER un-reel last wrap of cable from drum.
12. WARNING NEVER wrap cable around load.
13. REMEMBER - in lifting a heavy load, the weight can create enough tipping moment to overturn the vehicle.
14. WARNING NEVER attempt to lift or drag a load from the side- the boom can fail far below its rated capacity.
15. Oil gears as required.
16. Periodic adjustment of hoist worm brake may be required (NOT NEEDED FOR 2003).
17. WARNING NEVER weld, modify, or use unauthorized components on any Auto Crane unit. This will void any warranty or liability. Also failure of the crane may result.
18. An important item which an operator should consider and use properly is the hoist hook. It should be checked on a 30-day basis for distortion or cracks.
19. WARNING NEVER place a chain link on the tip of the hook and try to lift a load with the hoist.
20. WARNING NEVER use a sling bar or anything larger than the hook throat which could prevent the hook from closing with the block, thus negating the safety feature.
21. WARNING In using a safety hook, ALWAYS insure that the hook throat is closed before lifting a load. Proper attention and common sense applied to the use of the hoist hook and various slings will prevent possible damage to material being hoisted and may prevent injury to personnel.
22. WARNING NEVER hold any pendant Select switch on that will negate safe operating conditions.
23. ALWAYS store outriggers before road travel.

OPERATION OF UNIT

1. Make sure this manual has been thoroughly read by all crane operating personnel.
2. A routine inspection of the crane should be mandatory before each operating day. Any defects should be corrected immediately.
3. At a job site the vehicle should be positioned so that the crane can adequately reach the load within the rated capacity (centerline of rotation to hoist hook).
4. Keep the vehicle as level as possible during operation.
5. Engage emergency brake, and turn ignition off with transmission left in gear or in park (for automatic transmissions). This is for Auto Crane units requiring only battery operation. For larger Auto Crane units requiring battery and hydraulic operation, engage emergency brake and place gear select in neutral; press clutch and pull PTO knob in gear; release clutch and set throttle control to proper engine speed.
WARNING: DO NOT EXCEED ENGINE SPEED NECESSARY TO MEET PUMP RPM REQUIREMENT - (see hydraulic section) POSSIBLE DAMAGE MAY RESULT.
6. Always use outriggers from the truck to the ground. Be sure these are firm and adequately positioned.
7. Then remove pendant control from cab (on smaller units) and plug into receptacle on crane. Crane is now ready for operation. On Auto Crane's larger units, remove pendant control from guard and unwrap cable from boom. Crane is now ready for operation.
8. Always boom up before rotating so that the boom will clear the required boom support.
9. When extending the boom always maintain clearance between the boom crown and the traveling block or hoist hook.
10. Always observe safe and practical operation to avoid possible accidents. Refer to Safety Tips and Precautions.
11. After completing lifting operations, return the boom to stowed position on the boom support. Avoid excess pressure on the boom support.
12. Store pendant control on proper location (in cab or on crane).
13. Return outriggers to stowed position. Make sure they are pinned in place or jacklegs are returned to compartment.
14. Check work area for any tools or equipment not stored.
15. Press clutch and disengage PTO. Release throttle control and emergency brake.
16. Report any unusual occurrence during crane operation that may indicate required maintenance or repair.

MAINTENANCE OF BATTERIES

Maintenance of Auto Crane unit batteries differs very little from the generally prescribed maintenance of any lead acid battery. All batteries must be kept properly charged; they must be kept properly filled with water; and they must be kept relatively clean.

Many things affect the proper charge to a battery, such as regulator settings, the proper tightness of belts on the alternator or generator, and good, clean connections of all cables and wires at the battery, regulator, starting motor, alternator or generator, and – most important – the ground connections.

Keeping the battery as fully charged as possible without overcharging is of extreme importance, especially when vehicles are left outside for extended periods of time in extremely cold climates. A battery can freeze; freezing points for various specific gravities of acid are as follows:

Specific Gravity (Corrected to 80°F)	Freezing Temperature Degrees F.
1.280	-90°F
1.250	-62°F
1.200	-16°F
1.150	5°F
1.100	19°F

From the above, it is apparent that a half-charged battery (about 1.200 specific gravity) cannot stand for any length of time at – 20°F or it will freeze.

The main reason for keeping the battery as fully charged as possible without overcharging, of course, is to assure that power is available even though the vehicle has been standing for some time.

The battery should be properly filled with water at all times. If the electrolyte level is allowed to fall below the top of the plates, the results become threefold: 1, the exposed portion of the plate will become sulfated; 2, the portion of the plate exposed is not usable; and 3, that portion of the acid remaining becomes more concentrated and may cause more rapid deterioration of the remaining parts of the battery.

The battery should be kept clean. Batteries filled with acid and which are not in use self-discharge to a limited degree because of the nature of the materials within the battery; but if dirt is allowed to collect on the top of the battery, and this dirt absorbs moisture, an electrical path can be set up between the various terminals of the battery of the ground. Once such a path has been established, the self-discharge of the battery is considerably accelerated. This also accelerates corrosion of the battery cables at the terminals.

Periodic Maintenance is Needed.

A definite program of periodic maintenance of all batteries should be conducted on a regular basis. Periodic maintenance includes checking belts for tightness on the charging equipment, checking battery electrolyte levels, checking cables for good connections, and cleaning where corrosion is apparent. When corrosion is cleaned off, the cable terminals and battery terminals should be coated with a light coating of petroleum jelly before they are replaced. When terminals are cleaned the top of the battery should be cleaned with a mild solution of soda water.

If the condition of the battery is in question, it should be removed from the vehicle, taken to the shop, and allowed to reach room temperature. It should then be recharged until specific gravity readings are unchanged over three readings taken at one-half hour intervals. If the specific gravity readings are fairly uniform, the battery should be checked with a high rate tester in accordance with instructions on the tester. A load test is the best test one can make on a battery.

Low maintenance batteries should not be used on Auto Cranes or trucks equipped with Auto Cranes. These batteries are not designed for "deep" discharge.

If, after charging, it is noted that the specific gravity reading of one cell is 30 points less than any of the other cells, it may be assumed that that cell is bad and that the battery should be replaced. If all cells are uniform but not up to full charge, a low rate of charge should be attempted for an extended period of time. This usually will recover a badly sulfated battery.

If it necessary to replace a battery, and a dry charge battery is used, the following procedure applies:

1. Fill the battery with electrolyte of the proper specific gravity.
2. Place the battery on charge in accordance with instructions given by the manufacturer.

It is essential that the second step above be followed to assure that the battery going on the vehicle is fully charged.

It is also very important that the battery hold-downs be checked periodically to assure that the batteries are properly positioned to avoid vibration problems, breakage of cables, or terminal breakage. Care must be taken to avoid cracking or breaking containers or covers by tightening hold-down fixtures excessively, yet they must not be so loose that breakage results from a too loose hold-down.

WIRE LINE LUBRICATION

Lubrication of the wire line serves two important purposes: (1) helps to prevent corrosion; (2) lubricates the cable strands to reduce wear due to flexing and abrasion caused by contact with the sheaves, rollers, and cable on the drum.

PREPARATION:

Remove rust and foreign matter with a wire brush and wipe clean. Be sure cable is dry.

APPLICATION:

Two methods are illustrated in figures 1 and 2. A light weight motor oil may be used, as in figure 1; or a heavier lubricant such as grease gun lubricant, as in figure 2.

Illustrated in figure 1 is one easy and effective method of applying lubrication. Dip the brush into the lubricant and apply. In some cases a rag or piece of sheepskin is dipped in the lubricant and used to swab the lubricant on to the rope.

Another simple method is shown in figure 2. Leather gloves are preferred to canvas because of greater protection and less penetration of the grease.

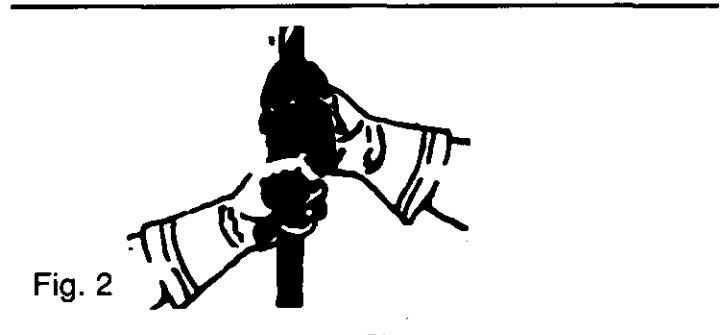
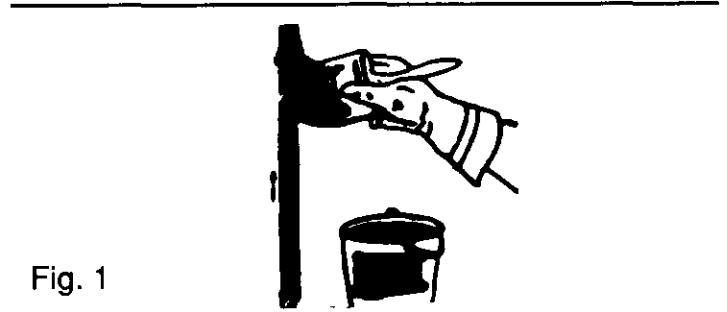

"LIFE OF WIRE LINE"

So many variable factors can cause the deterioration of wire line cable that it is not possible to determine a definite life expectancy.

Some of these factors are:

1. Load being handled.
2. Corrosive conditions.
3. Maintenance of the unit.
 - a. Keep the sheaves turning freely.
 - b. Maintain tension of cable to insure proper spooling.
 - c. Lubricate line (See above).
 - d. Avoid kinks in cable.
 - e. Avoid abrasive action and contact with sharp corners.
4. Frequency of use.

Auto Crane units, up to 2400 pound ratings, use 3/16 inch diameter galvanized preformed 7 x 19 aircraft cable which, when new, has a minimum strength of 4,200 pounds. It is recommended when 1200 pound loads are exceeded to use a two-part line with a traveling block. It can be seen that there is a safety factor of 3.5 to 1 when the cable is new.

Keeping the above factor of safety in mind and knowing the kind of loads that will be handled, the user can determine by inspection of the cable as to when it should be replaced.

Items to look for while inspecting the cables are:

1. Broken strands
2. Kinks and flattened sections.
3. Corrosion and abrasion.

2-1.0.0

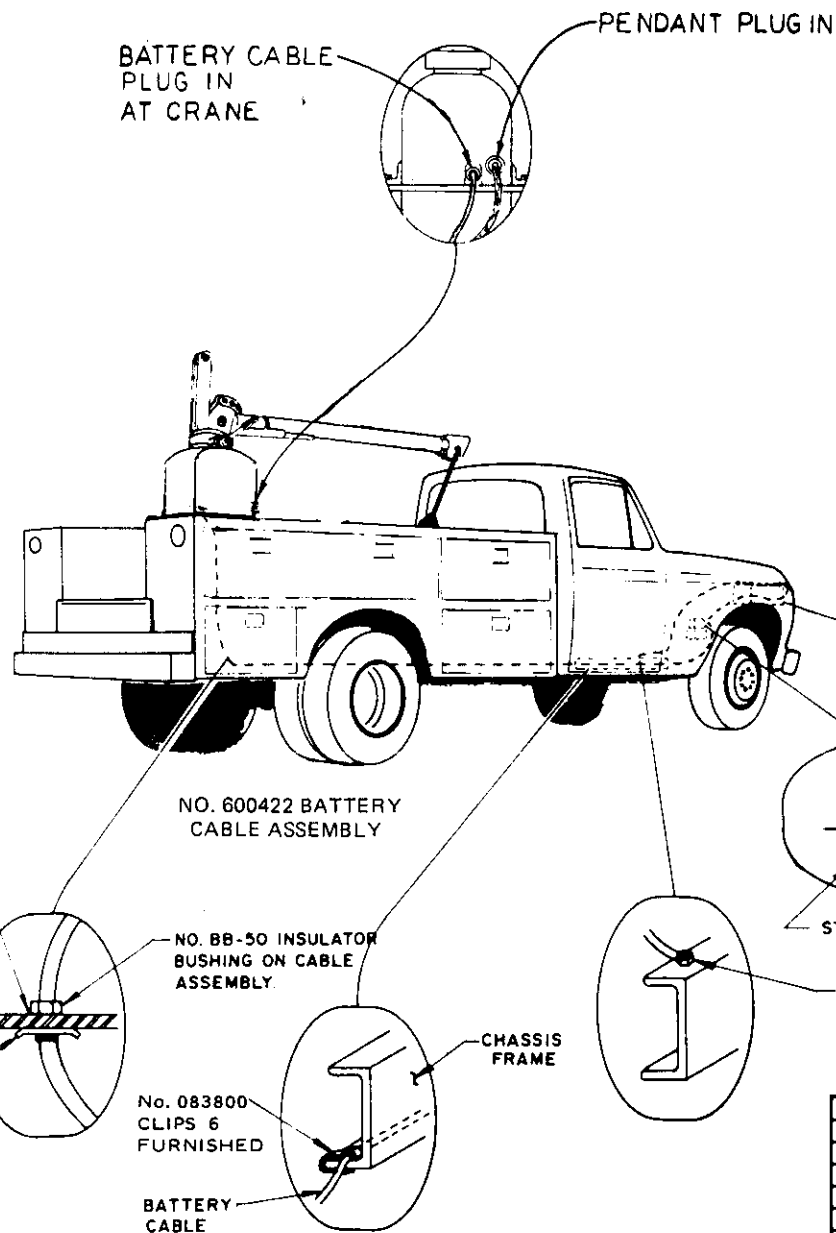

1. DRILL 13/16 DIAMETER HOLE IN FLOOR. INSTALL CABLE, AND BUSHING WHICH IS FURNISHED ON CABLE, AS SHOWN. WRAP ELECTRICAL TAPE AROUND CABLE SO IT WILL FIT BUSHING SNUG.
2. RUN CABLE INSIDE CHASSIS FRAME TO STARTER SOLENOID BATTERY CONNECTION. LOCATE CABLE SO THAT IT WILL BE PROTECTED, AVOID SHARP EDGES. INSTALL THE NO. 838 FRAME CLIPS TO HOLD CABLE SECURELY IN PLACE. IF SURPLUS CABLE EXISTS THE CABLE CAN BE CUT OFF, AND EXTRA TERMINAL FURNISHED WITH CABLE INSTALLED.
3. REMOVE NUT ON SOLENOID BATTERY TERMINAL POST, INSTALL CRANE POWER CABLE, REPLACE NUT AND TIGHTEN.
4. IF THE BATTERY IS GROUNDED TO THE ENGINE IT MAY BE NECESSARY TO ADD AN ADDITIONAL GROUND CABLE FROM THE ENGINE TO THE CHASSIS FRAME IN ORDER TO OBTAIN MAXIMUM POWER AT CRANE. THE CRANE SHOULD BE GROUNDED TO THE CHASSIS FRAME. THIS IS USUALLY ACCOMPLISHED THROUGH THE MOUNTING BRACKET.

ITEM	D/S	PART NO	DESCRIPTION
QUANTITY		LIST OF MATERIAL	
UNLESS OTHERWISE NOTED ALL DIMENSIONS ARE IN INCHES TOLERANCES UNLESS OTHERWISE SPECIFIED			
DRAWN BY		AUTO CRANE COMPANY	
DATE		P. O. BOX 45548 • TULSA, OKLAHOMA 74115	
CHK'D BY		9260 BROKEN ARROW EXPRESSWAY • 918 627 9475	
DATE		TITLE	
ENG BY		INSTALLATION - BATTERY CABLE	
DATE		SCALE	DRAWING NO
TOLERANCES NOT SHOWN ABOVE ARE PER ANSI Y14.5 1973		C	AW-6018
THIS PRINT IS THE PROPERTY OF AUTO CRANE CO AND MUST NOT BE USED IN ANY MANNER DETRIMENTAL TO THEIR INTERESTS		WEIGHT	REVISION
NEXT ASSY			SHEET 1 OF 1

NOTE:
For mounting bolt hole
pattern - see dimensional
drawing AW-2003

MAKE SURE HOIST ANCHOR IS USED
FOR OVER THE ROAD USE.

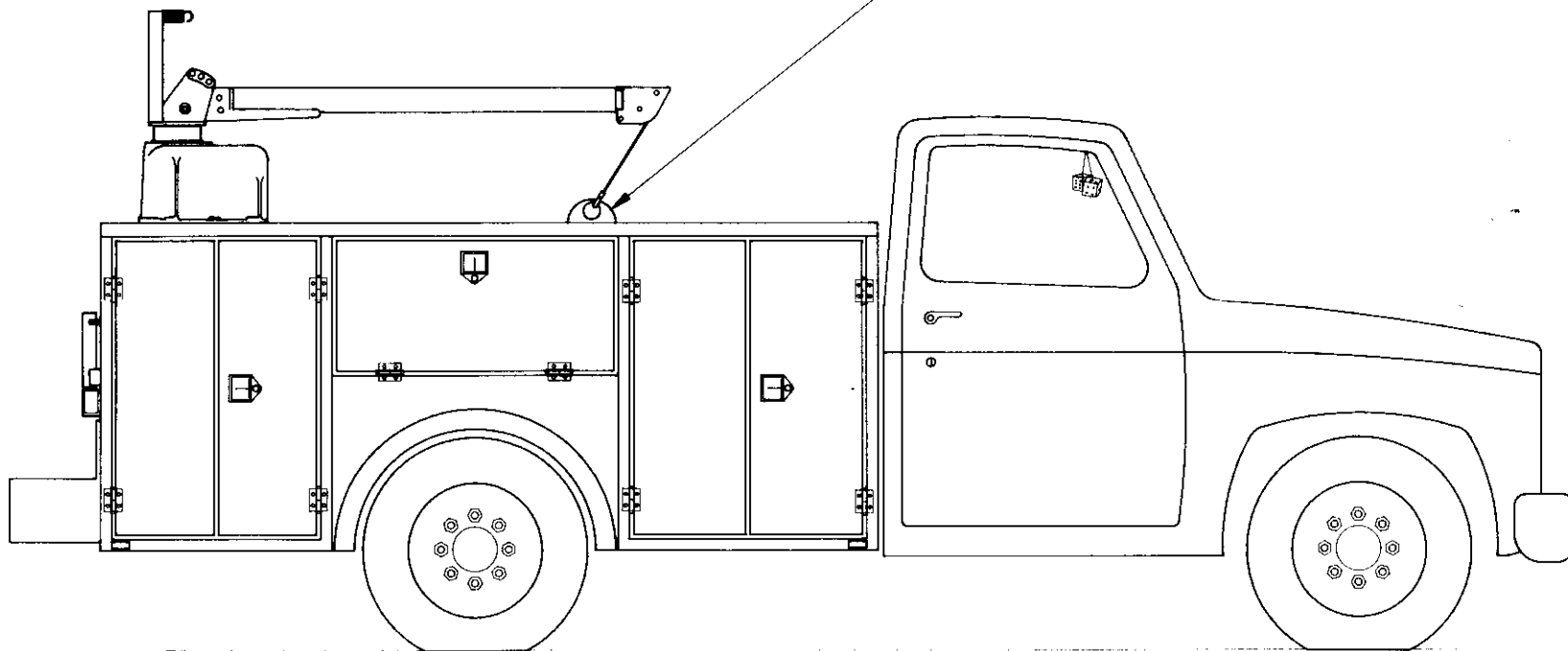

2-2.0.0

AW-087, 2003

PLOT SCALE: .0833

2003 OPERATING INSTRUCTIONS

TO EXTEND: RELEASE BRAKE (2) AND TURN BOOM TO ANY CONVENIENT LOCATION FOR EXTENDING. PULL UPPER BOOM (3) OUTWARDLY WHILE PUSHING "DOWN" BUTTON (1). WHEN UPPER BOOM HITS STOP, ROTATE BOOM UNTIL LUG (4) WILL SLIDE THROUGH SLOT (5) IN SLEEVE LOCATED IN END OF LOWER BOOM (6). ROTATE UPPER BOOM UNTIL LUG (4) IS ON UNDERSIDE. PUSH BOOM IN UNTIL LUG (4) ENGAGES NOTCH IN END OF LOWER BOOM.

BOOM IS NOW READY TO RAISE

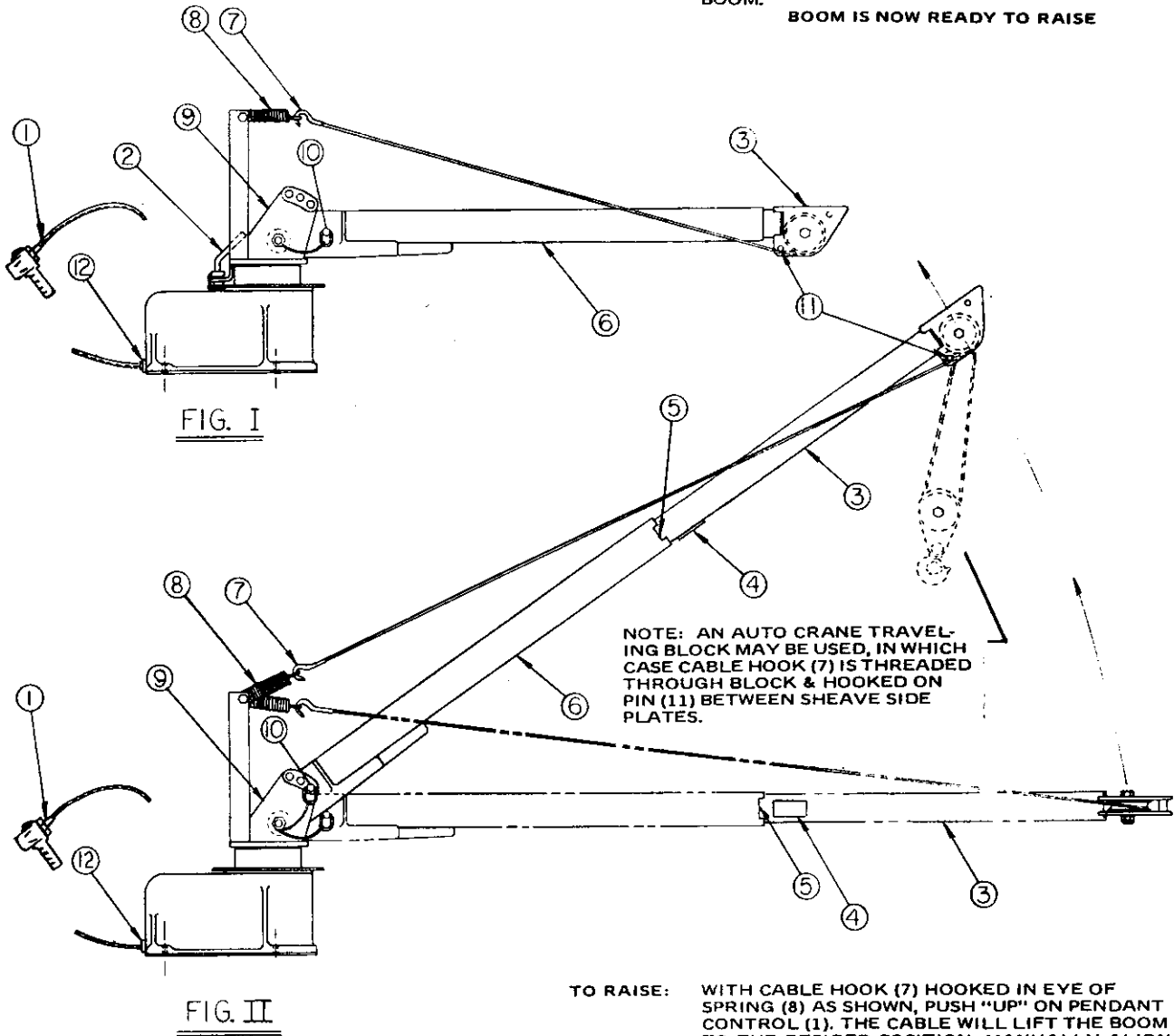

TO RAISE: WITH CABLE HOOK (7) HOOKED IN EYE OF SPRING (8) AS SHOWN, PUSH "UP" ON PENDANT CONTROL (1). THE CABLE WILL LIFT THE BOOM TO THE DESIRED POSITION. MANUALLY ALIGN HOLES IN HINGED END OF BOOM (6) WITH HOLES IN SIDE PLATE OF QUILL (9) INSERT POSITION PIN (10). RELEASE HOOK (7) FROM SPRING (8).

THE UNIT IS NOW READY TO LIFT THE LOAD

TO RETURN BOOM TO POSITION SHOWN IN VIEW I: PERFORM THE ABOVE OPERATIONS THE SAME AS BEFORE, ONLY IN REVERSE ORDER.

CAUTION: WHEN SPOOLING CABLE OUT OR IN, MANUALLY PULL ON CABLE TO INSURE PROPER SPOOLING ON DRUM. ALSO WHEN NOT IN USE DISCONNECT PENDANT CONTROL AT PLUG IN (12) AND STORE IN CABLE OF TRUCK TO AVOID UNINTENTIONAL OR UNAUTHORIZED OPERATION OF THE UNIT.

PROCEDURE FOR REPLACEMENT OF HOIST CABLE

STEPS:

1. — PRESS PENDANT "DOWN" TOGGLE & RUN ALL OF OLD HOIST CABLE OFF DRUM (A).
2. — THEN REMOVE POWER CABLE (B) AT "TWECO" CONNECTION AT BASE OF UNIT.
3. — IF EQUIPPED WITH REMOVABLE PENDANT CABLE (C) ALSO REMOVE FROM CONNECTION AT BASE OF UNIT.
4. — WITH BOOM (D) EITHER LAYING IN BOOM SUPPORT RACK OR BY BLOCKING UP TO BOTTOM OF BOOM, REMOVE THE (4) 1/2" MOUNTING BOLTS (E) & THE (2) 1/4" BOLTS (F) THAT HOLD THE CASE (G) TO THE MOUNTING PLATE (H).
5. — LIFT CASE & BOOM AS AN ASSEMBLY UP VERTICALLY UNTIL CASE CLEARS ACTUATOR (I) & SET TO ONE SIDE.
6. — REPLACE (1) OF 1/2" BOLTS IN THE MOUNTING BRACKET & TIGHTEN SO AS TO OBTAIN A POSITIVE GROUND TO UNIT TO PREVENT ARCING OF NEW HOIST CABLE.
7. — REINSTALL POWER CABLE (B) & PENDANT CABLE (C).

STEPS:

8. — REMOVE CABLE SET SCREW (J) IN DRUM & REMOVE OLD HOIST CABLE FROM DRUM. USE PENDANT CONTROL IF NECESSARY TO ROTATE DRUM FOR ACCESS TO SET SCREW.
9. — REMOVE OLD HOIST CABLE (K) FROM CASE & BOOM BY PULLING ON HOOK END OF HOIST CABLE.
10. — INSTALL THE NEW HOIST CABLE BY INSERTING PLAIN END IN CROWN (L) OVER CROWN SHEAVE (M) & FEEDING IT BACK TO & OVER PIVOT SHEAVE (N) & THEN DOWN THRU QUILL (O) & OUT BOTTOM OF CASE & INTO DRUM AS SHOWN & TIGHTEN SET SCREW.
11. — WITH RAG OR LEATHER GLOVE HOLD HOIST CABLE UNDER TENSION & WIND CABLE ON DRUM TIGHTLY UNTIL HOOK (P) ALMOST REACHES CROWN SHEAVE.
12. — REMOVE THE (1) 1/2" BOLT INSTALLED IN STEP 6.
13. — REMOVE POWER CABLE & PENDANT CABLE.
14. — REINSTALL CASE & BOOM ASSEMBLY OVER MOUNTING PLATE. CAUTION: APPLY TENSION ON HOOK END OF CABLE SO IT WILL NOT BECOME ENTANGLED INSIDE THE CASE.
15. — REINSTALL THE (4) MOUNTING BOLTS & TIGHTEN SECURELY.
16. — REINSTALL THE (2) 1/4" BOLTS & TIGHTEN.
17. — REINSTALL POWER CABLE & PENDANT CABLE.

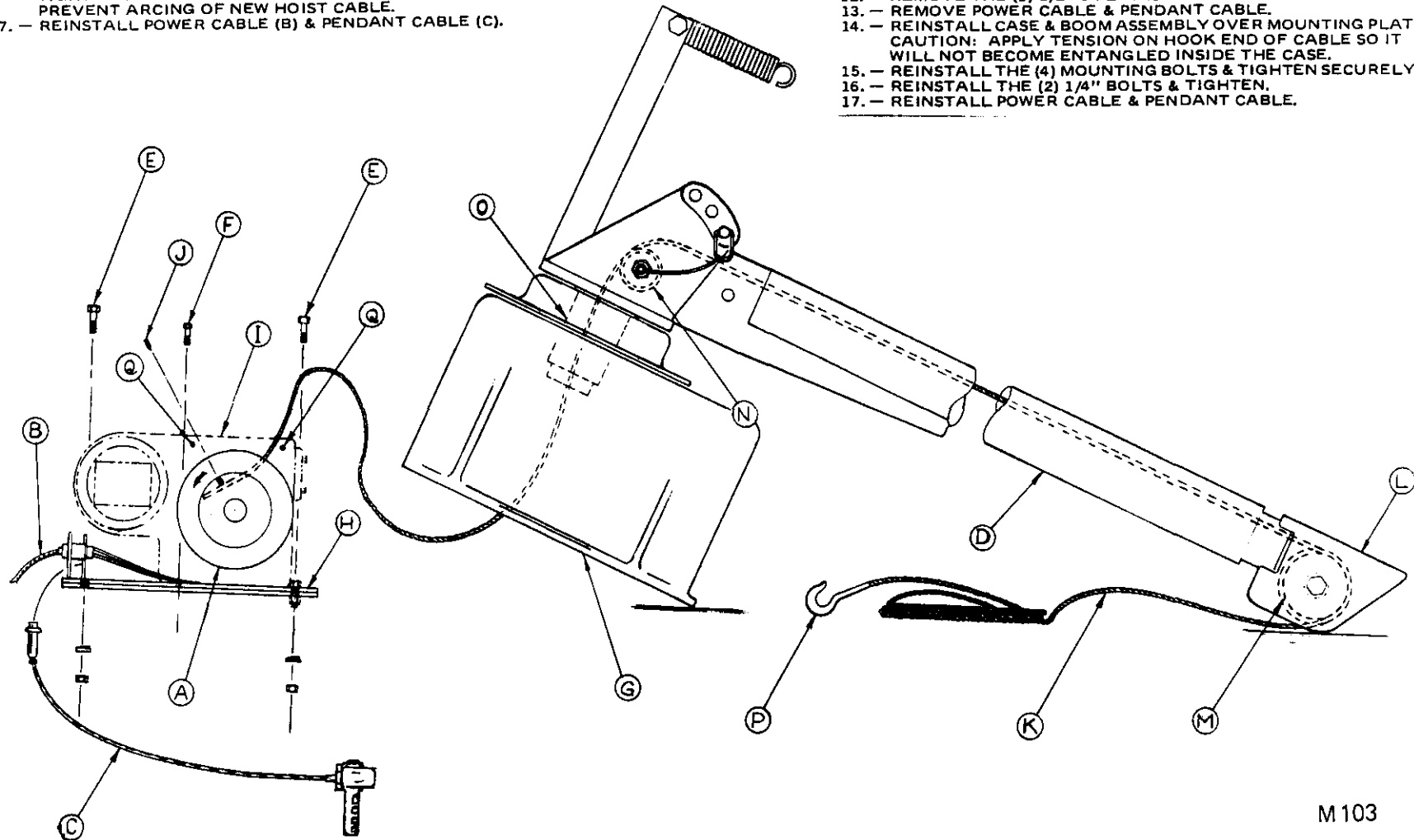

3-2.0.0

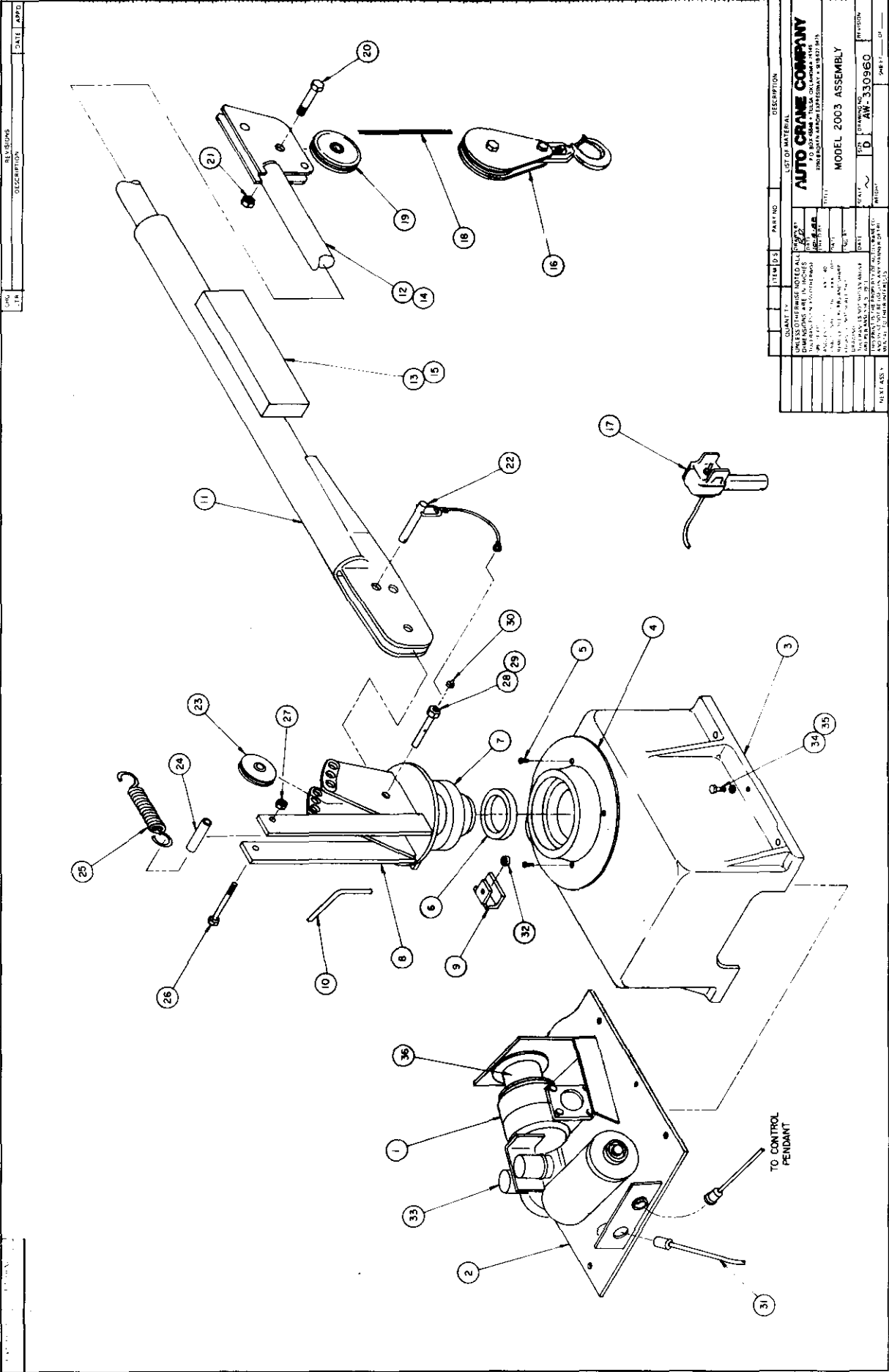

QUANTITY	ITEM ID	PART NO.	DESCRIPTION
LIST OF MATERIAL			
AUTO CRANE COMPANY			
TO THE ENGINEERING DEPARTMENT			
INDUSTRIAL DIVISION, 1000 HARRIS STREET, ST. LOUIS, MO. 63103			
MODEL 2003 ASSEMBLY			
DATE	DESIGNED BY	SCALE	REV. NO.
CHECKED BY			DATE
APPROVED BY			DATE
DRAWN BY			
PART NO. D AM-330960			
REV. NO. 01			
PAGE 1 OF 1			

GENERAL ASSEMBLY 2003, AW-330960

ITEM	QTY.	PART NO.	DESCRIPTION
1	1	300006	HOIST ASSEMBLY
2	1	300600	FRAME, HOIST
3	1	301001	CASE, HOIST
4	1	200414	BRAKE, RING
5	4	007200	SCREW, MACH. FL. HD. 5/16 X 3/4
6	1	200308	BEARING
7	1	200205	BEARING
8	1	200403	QUILL ASSEMBLY
9	1	202301	CLAMP, SHOE BRAKE
10	1	202400	HANDLE, BRAKE
11	1	330964	BOOM, LOWER 9' (SEE NOTE 1)
12	1	200609	BOOM, UPPER 9' (SEE NOTE 1)
13	1	666400	LOAD SENSOR (OPT.)
14	1	REF.	BOOM STOP INST. (M-105)
15	1	REF.	SEE RELAY PANEL ASSEMBLY (AW - 330411)
16	1	100300	TRAVELING, BLOCK
17	1	675205	PENDANT
18	45'	201245	CABLE 3 / 16"
19	1	200909	SHEAVE (BEARING 200100)
20	1	012200	SCREW, 5 / 8 NF X 1 3 / 4
21	1	018100	NUT, LOCK 5 / 8 NF
22	1	201104	PIN, BOOM POSITION
23	1	200808	SHEAVE
24	1	202200	SPACER
25	1	201800	SPRING
26	1	006801	SCREW, 1 / 2 NF X 4"
27	1	017700	NUT, LOCK 1/2 NF
28	1	201001	PIN HINGE
29	1	018600	NUT, LOCK 3/4 NF
30	1	239300	ZERK, GREASE 1/8 NPT
31	22'	600422	POWER CABLE
32	1	202201	SHOE, BRAKE
33	1	330411	RELAY ASSEMBLY
34	2	006200	SCREW 1/4 NC X 1 1/4
35	2	020200	WASHER, SP. LK. 1/4
36	1	400301	DRUM

NOTES:

1. BOOM LOWER 14', 330965
BOOM UPPER 14', 200614

FIXTURE NO.	FINISHING
-------------	-----------

CHG	REVISIONS	DATE	APPD
LTR	DESCRIPTION		

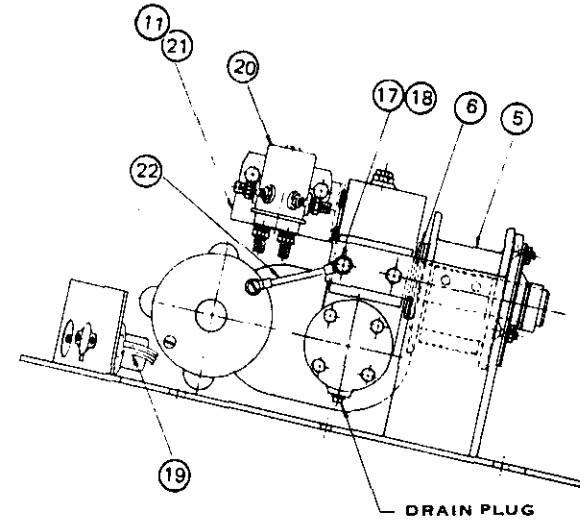
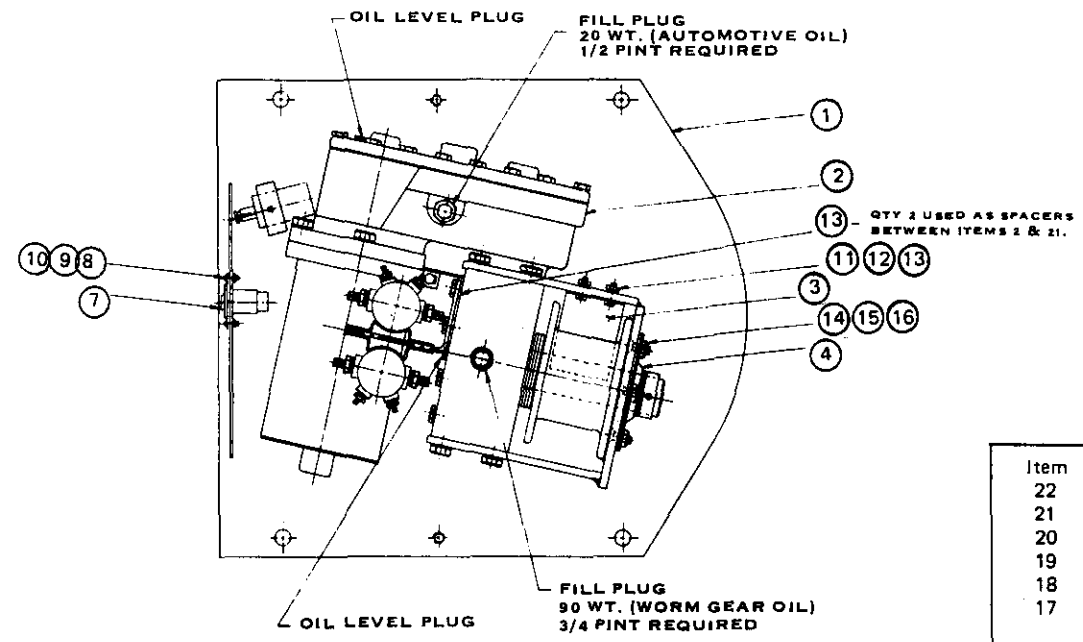

MAINTENANCE:
CHANGE OIL AT LEAST
ONCE A YEAR.

Item	Qty	Part No.	Description
22	1	300039	CONDUCTOR ASSY.
21	1	300037	BRACKET, RELAY (REF.)
20	2	200182	RELAY, 12 V. (REF.)
19	1	330411	WIRING ASSEMBLY
18	4	020600	LOCKWASHER 5/16
17	4	007807	BOLT HEX HD 5/16-18 NC x 3/4" LG.
16	3	021100	LOCKWASHER 3/8
15	3	017100	NUT HEX 3/8-16 NC
14	3	008300	SCREW FLAT HD 3/8-16 NC x 1" LG.
13	4	020200	LOCKWASHER 1/4
12	2	015900	NUT HEX 1/4-20
11	4	005500	BOLT HEX HD 1/4-20 x 3/4" LG
10	2	019600	LOCKWASHER #6
9	2	015400	NUT HEX #6-32
8	2	000605	SCREW RD.HD #6-32 x 3/8" LG
7	1	676400-001	PLUG ASSY.
6	3	022500	SPACER
5	1	400301	DRUM
4	1	300403	BEARING
3	1	300036	RETAINER, CABLE
2	1	300038	ACTUATOR ASSEMBLY
1	1	300600	FRAME-HOIST BASE ASSY.

QUANTITY	LIST OF MATERIAL
UNLESS OTHERWISE NOTED ALL DIMENSIONS ARE IN INCHES. TOLERANCES UNLESS OTHERWISE SPECIFIED	AUTO CRANE COMPANY P.O. BOX 16686 • FULDA, CALIFORNIA 95116 2000 SHOOKEN AVENUE (APPROXIMATELY) • BIRNEY, ILL.
ANGLES: 1/2" HOLE: 1/8" FRACTIONAL: 1/16" DEC: .010	
REMOVE ALL BURRS AND SHARP EDGES. DO NOT SCALE THIS DRAWING.	TITLE: HOIST ASSEMBLY SCALE: D SIZE: AW-300006 DRAWING NO. SHEET 1 OF 1
100063	TOL. FRANCES NOT SHOWN ABOVE ARE PER ANSI Y14.5-1973 THIS PRINT IS THE PROPERTY OF AUTO CRANE CO. AND MUST NOT BE USED IN ANY MANNER DETRIMENTAL TO THEIR INTERESTS.

4-2.0.0

ORG. DIV.	REVISIONS	DATE	APP'D.
	DESCRIPTION		

FIGURE NO.	PART NO.

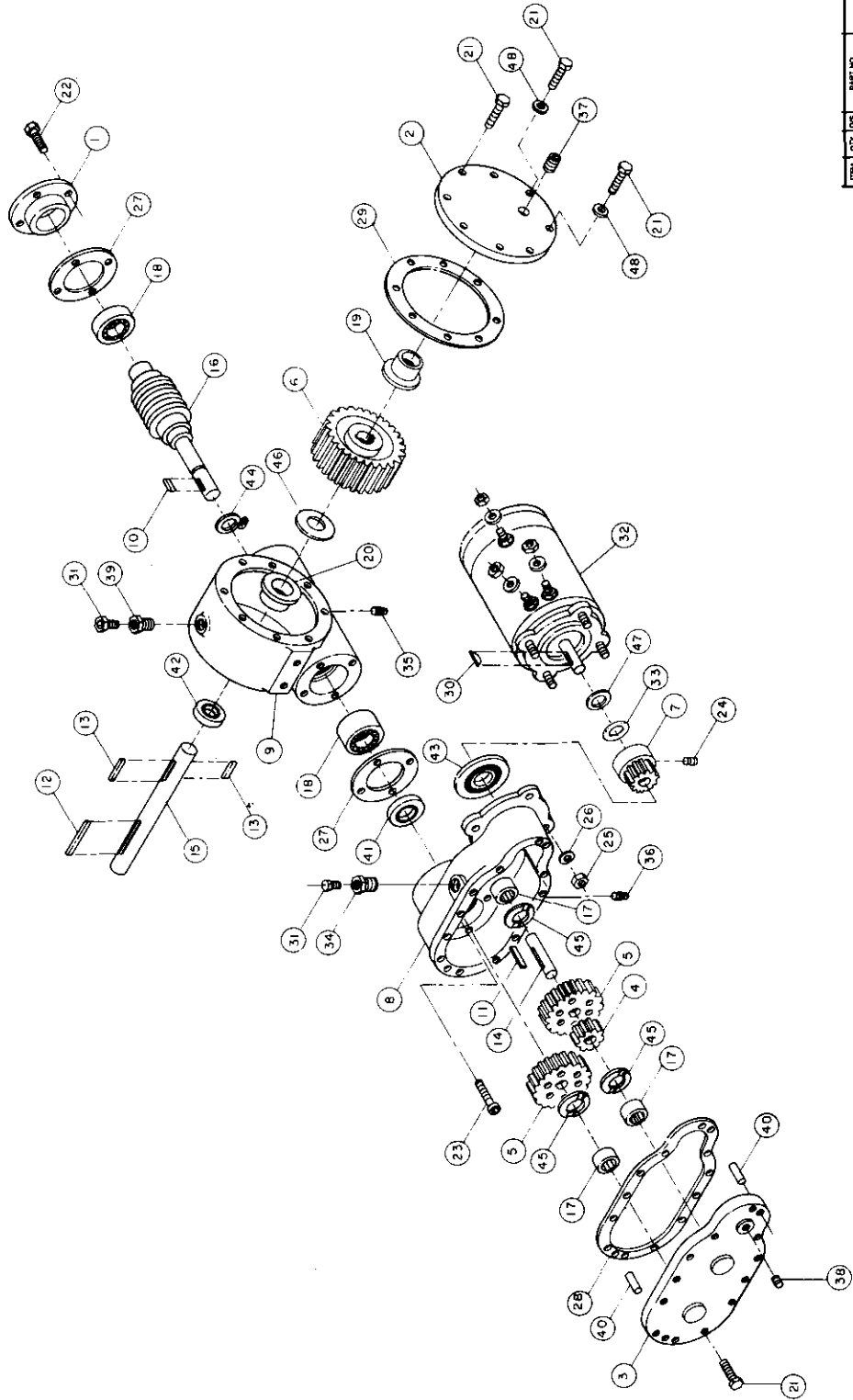

ITEM		QTY	ORG.	PART NO.	DESCRIPTION
ALL DIMENSIONS UNLESS ALL DIMENSIONS ARE IN INCHES DIMENSIONS ARE IN MILLIMETERS UNLESS OTHERWISE SPECIFIED FINISHES: UNLESS OTHERWISE SPECIFIED DIMENSIONS: UNLESS OTHERWISE SPECIFIED DIMENSIONS: UNLESS OTHERWISE SPECIFIED DIMENSIONS: UNLESS OTHERWISE SPECIFIED DIMENSIONS: UNLESS OTHERWISE SPECIFIED					
AUTO CRANE COMPANY 1500 N. 10TH ST. SUITE 100 DENVER, CO 80202 TEL: (303) 733-1111 FAX: (303) 733-1112 E-MAIL: SALES@AUTO-CRANE.COM WWW.AUTO-CRANE.COM					
ACTUATOR ASSEMBLY DATE: _____ DRAWN BY: _____ CHECKED BY: _____ DATE: _____ REVISION: _____ PART NO.: DAW-00038 SHEET: 1 OF 2					

ACTUATOR ASSEMBLY AW - 300038

ITEM	QTY.	PART NO.	DESCRIPTION
1	1	300040	CAP - BRG.
2	1	300041	COVER - GH
3	1	300042	COVER - SPUR GH
4	1	300043	GEAR - IDLER
5	2	300044	GEAR - INTER. & DRIVE
6	1	300045	GEAR - RH
7	1	300046	PINION
8	1	300047	HOUSING, SPUR GEAR
9	1	300048	HOUSING, GEAR
10	1	300049	KEY, SQ. ENDS
11	1	300050	KEY, RD. ENDS
12	1	300051	KEY, OUTPUT
13	2	300052	KEY, RD. ENDS
14	1	300053	SHAFT, SPUR
15	1	300054	SHAFT, OUTPUT
16	1	300055	WORM, RH
17	3	300056	BEARING, NEEDLE
18	2	300057	BEARING, BALL
19	1	300058	BUSHING
20	1	300059	BUSHING
21	20	050500	CAPSCREW, HX. HD. 1/4 NC X 3/4 GR.5
22	4	005604	CAPSCREW, HX. HD. 1/4 NC X 1"
23	4	300060	CAPSCREW, SOC. HD. 1/4 NC X 1 3/4
24	1	300061	SETSCREW, SOC. HD. 1/4 NC
25	3	017102	NUT, HX. 3/8 NFCP
26	3	021100	LOCKWASHER, 3/8" MED. SECT.
27	2	300062	GASKET
28	1	300063	GASKET
29	1	300064	GASKET
30	1	300065	KEY, MOTOR
31	2	300066	RELIEF FITTING
32	1	300067	MOTOR
33	1	300068	O - RING
34	1	300069	REDUCER
35	1	300070	PIPE PLUG
36	1	300071	PIPE PLUG
37	1	300072	PIPE PLUG
38	1	300073	PIPE PLUG
39	1	300074	REDUCER
40	2	300075	DOWEL PIN
41	1	300076	OIL SEAL
42	1	300077	OIL SEAL
43	1	300078	OIL SEAL
44	1	300079	SNAP RING
45	3	300080	WASHER, THRUST
46	1	300081	WASHER, THRUST
47	1	300082	WASHER, FIBER
48	2	300083	SEAL, THREAD

FIXTURE NO.	FINISH NO.

CHG LTR	REVISIONS		
	DESCRIPTION	DATE	APP'D

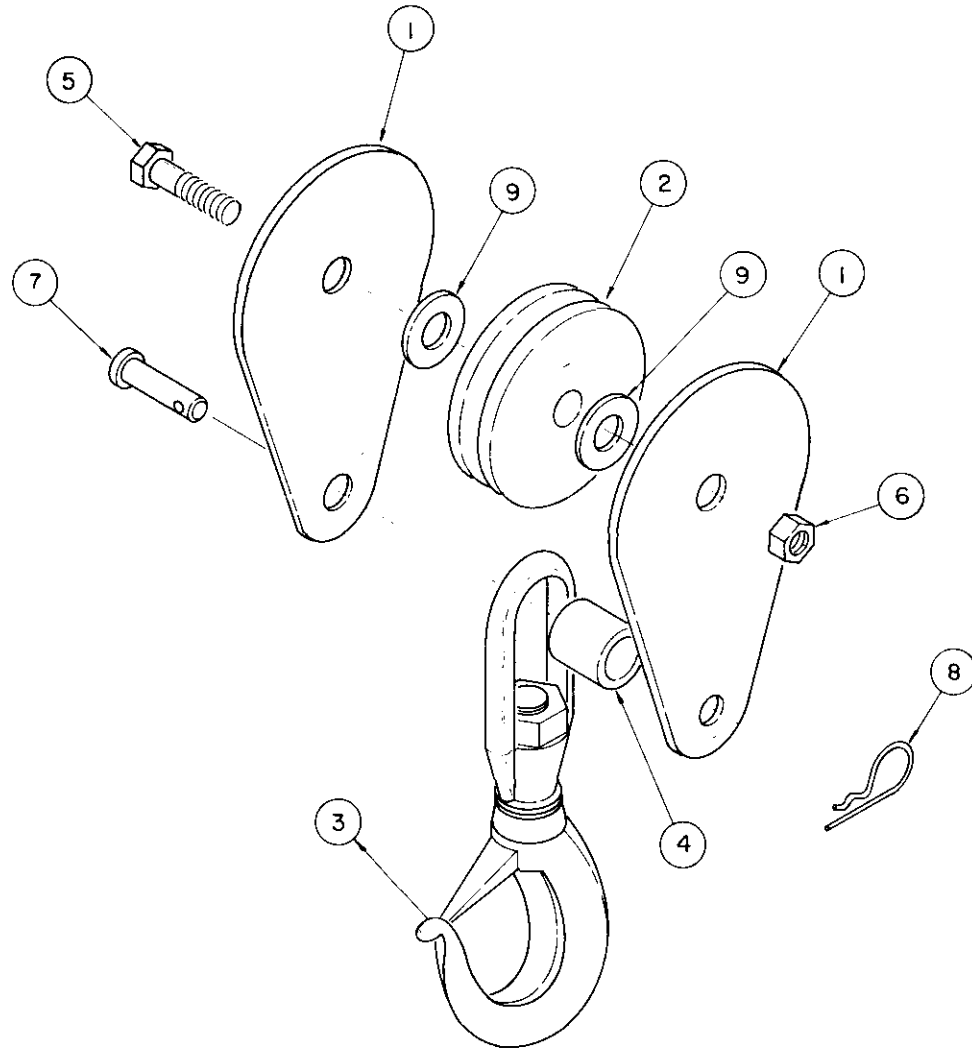

NOTE:
REF. - BEARING P/N 200100 USED IN SHEAVE ASSEMBLY, (200209) ITEM 2.

9	2	330100	WASHER, FLAT ADJUSTING
8	1	360124	HITCH PIN
7	1	330634	PIN, TRAVELING BLOCK
6	1	018100	NUT, HX. HLF. LK. 5/8"-18
5	1	013507	SCREW, HX. 5/8"-18X2" GR 5
4	1	800203-004	PIPE, BLACK 1/2"
3	1	100309	SWIVEL HOOK ASS'Y W/LATCH
2	1	200909	SHEAVE ASSEMBLY
1	2	100303	PLATE, SIDE SHEAVE

ITEM	D/S	PART NO.	DESCRIPTION
QUANTITY			
LIST OF MATERIAL			
UNLESS OTHERWISE NOTED ALL DIMENSIONS ARE IN INCHES. TOLERANCES UNLESS OTHERWISE SPECIFIED:			DRAWN BY <i>L.P.</i> DATE <i>1-18-00</i> CHK'D BY DATE ENG. BY DATE
ANGLES: 1/2" xx: 40 FRACTIONAL: 1/16 xxx: .010 REMOVE ALL BURRS AND SHARP EDGES DO NOT SCALE THIS DRAWING. TOLERANCES NOT SHOWN ABOVE ARE PER ANSI Y14.5 19/3			
THIS PRINT IS THE PROPERTY OF AUTO CRANE CO AND MUST NOT BE USED IN ANY MANNER DETRIMENTAL TO THEIR INTERESTS.			AUTO CRANE COMPANY TITLE TRAVELING BLOCK ASSEMBLY SCALE C SIZE AW-100300 REVISION SHEET <u>1</u> OF <u>1</u>
NEXT ASS'Y		WEIGHT	

4-4.0.0

FIXTURE NO.	FINISH NO.

CHG	REVISIONS		DATE	APP'D
	LTR	DESCRIPTION		

4-5-0-0

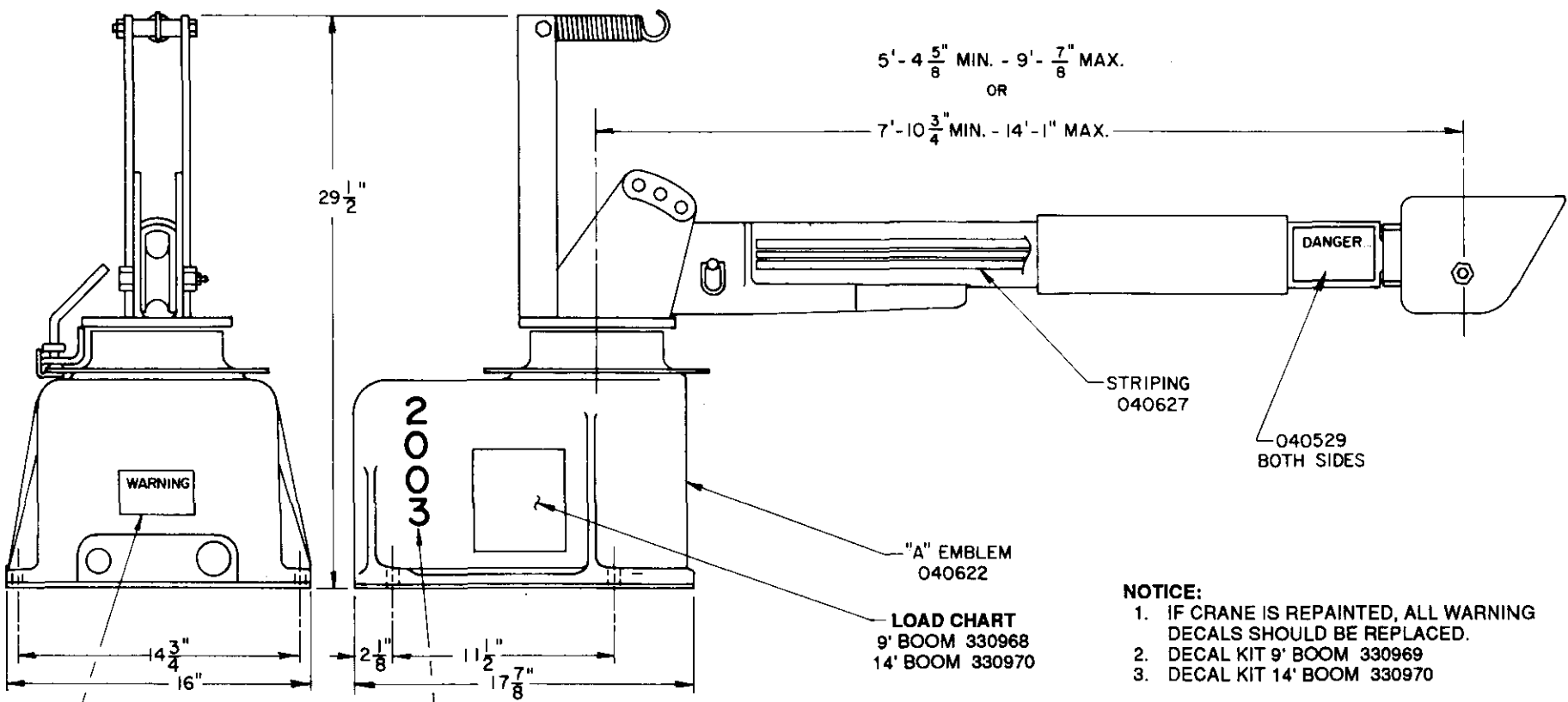

- NOTICE:**
1. IF CRANE IS REPAINTED, ALL WARNING DECALS SHOULD BE REPLACED.
 2. DECAL KIT 9' BOOM 330969
 3. DECAL KIT 14' BOOM 330970

NOTE:
ALL DIMENSIONS SHOWN ARE TYPICAL AND ARE SUBJECT TO CHANGE WITHOUT NOTICE.

330967
SHOWN THIS SIDE FOR CLARITY.

QUANTITY	ITEM	D/S	PART NO.	DESCRIPTION
LIST OF MATERIAL				
AUTO CRANE COMPANY P.O. BOX 46548 • TULSA, OKLAHOMA 74145 9280 B BOKEN ARROW EXPRESSWAY • 918-627-9475				
DRAWN BY <i>R.P.</i> DATE 1-30-00 CHK'D BY			TITLE DECAL AND DIMENSIONAL - 2003	
ANGLES: 1/2° XX: 40 FRACTIONAL: 1/16 .XXX: 010 REMOVE ALL BURRS AND SHARP EDGES. DO NOT SCALE THIS DRAWING. TOLERANCES NOT SHOWN ABOVE ARE PER ANSI Y14.5-1973			ENG BY DATE SCALE C DRAWING NO. AW-2003 REVISION	
THIS PRINT IS THE PROPERTY OF AUTO CRANE CO. AND MUST NOT BE USED IN ANY MANNER DETRIMENTAL TO THEIR INTERESTS.			WEIGHT SHEET ___ OF ___	
NEXT ASS'Y				

FIXTURE NO.	FINISH NO.

CHG LTR	REVISIONS		DATE	APP'D
		DESCRIPTION		

NOTE:
ADDITIONAL LENGTHS AVAILABLE
ON REQUEST.

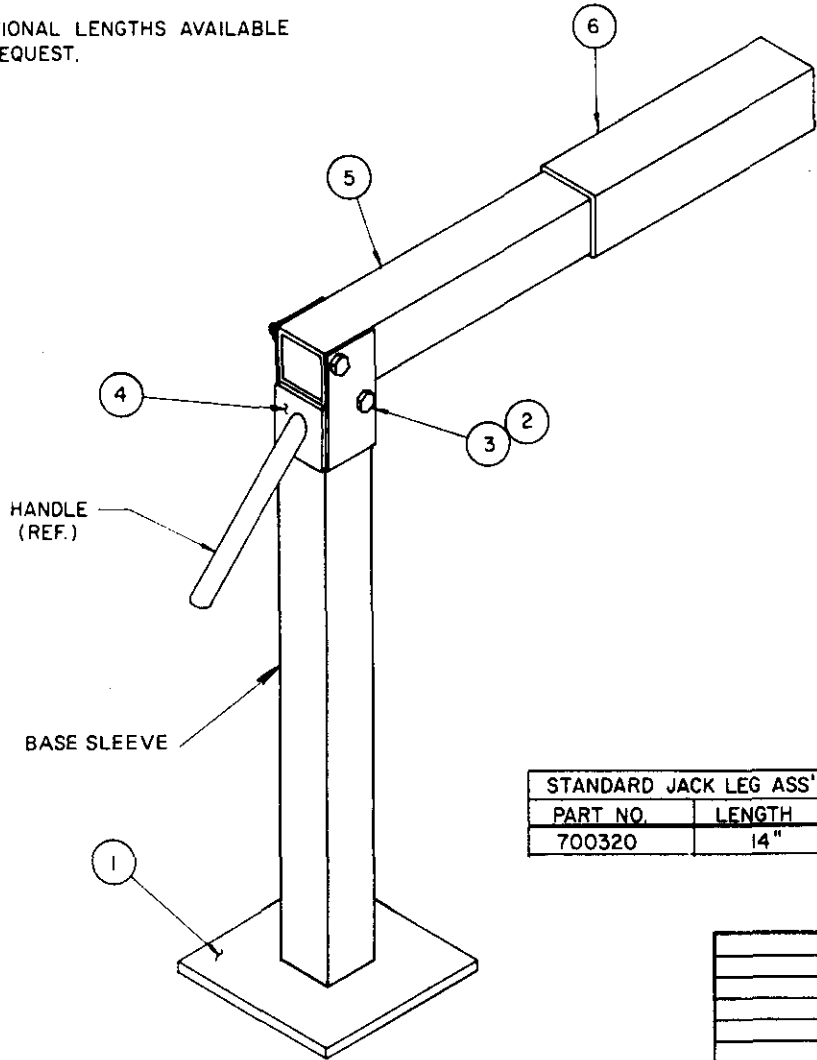

INSTALLATION INSTRUCTIONS (JACK LEG)

MAKE SURE TRUCK IS PARKED ON LEVEL SURFACE. WELD POCKET (Item 6) TO TRUCK BODY AT REAR JUST INSIDE BUMPER, OR DESIRABLE LOCATION. END OF POCKET SHOULD BE FLUSH WITH OUTSIDE OF THE TRUCK BODY. BE SURE THE POCKET IS WELDED SECURELY. NEXT, SLIDE HORIZONTAL MEMBER (Item 5) INTO POCKET. MAKE SURE LEG ASSEMBLY IS FULLY INSERTED IN POCKET.

JACK LEG IS READY FOR USE. UPON USE, MAKE SURE JACK LEG HAS ADEQUATE TENSION (SELF-DETERMINING), BEFORE SELF-LOCKING IN PLACE.

STANDARD JACK LEG ASS'Y	
PART NO.	LENGTH
700320	14"

6	1	200372	TUBE, POCKET
5	1	200282	MEMBER, HORIZONTAL
4	1	200074	TOGGLE
3	2	009101	CAPSCREW, HEX.HD. 3/8"NF X2-3/4"
2	2	017400	LOCKNUT, HEX. NF 3/8"
1	1	200454	BASE ASSEMBLY

4-6.0.0

QUANTITY		PART NO.		DESCRIPTION	
LIST OF MATERIAL					
UNLESS OTHERWISE NOTED ALL DIMENSIONS ARE IN INCHES TOLERANCES UNLESS OTHERWISE SPECIFIED			DRAWN BY DATE CHK'D BY		
ANGLES * 15' XX * 40			TITLE		
FRACTIONAL * 1/16 XX * 010			DATE		
REMOVE ALL BURRS AND SHARP EDGES DO NOT SCALE THIS DRAWING			ENG BY		
TOLERANCES NOT SHOWN ABOVE ARE PER ANSI Y14.5 1973			DATE		
THIS PRINT IS THE PROPERTY OF AUTO CRANE CO AND MUST NOT BE USED IN ANY MANNER DETRIMENTAL TO THEIR INTERESTS			SCALE	SIZE	DRAWING NO
NEXT ASS'Y	WEIGHT	REVISION	AW-700320	SHEET	OF

AUTO CRANE COMPANY
P O BOX 45548 • TULSA, OKLAHOMA 74145
9760 BROKEN ARROW EXPRESSWAY • 918 627 9475

JACK LEG ASSEMBLY, SMALL

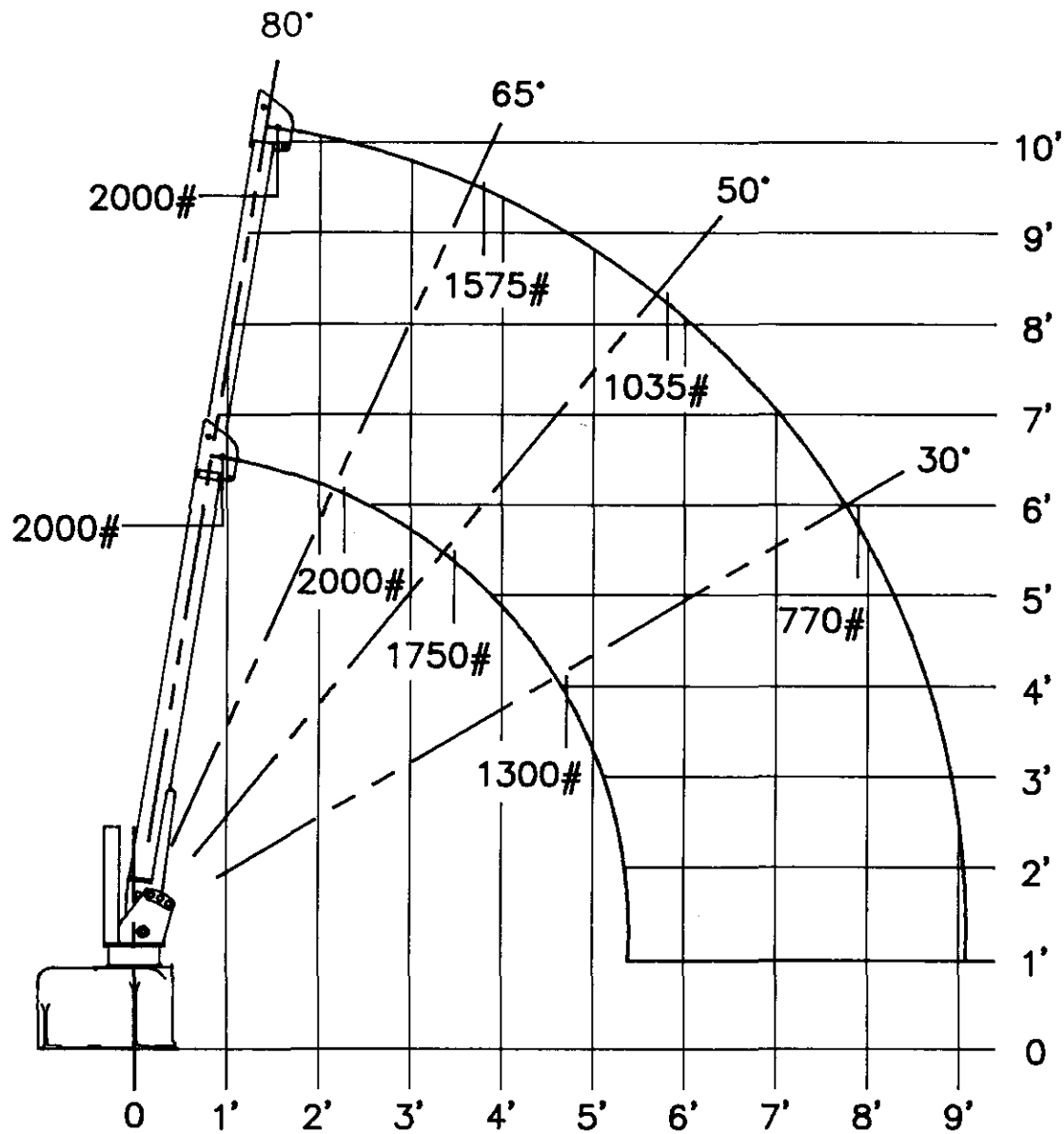

**HORIZONTAL REACH IN FT
CAPACITY IN POUNDS
FOR ALL LOADS OVER 1,000 POUNDS
USE DOUBLE LINE**

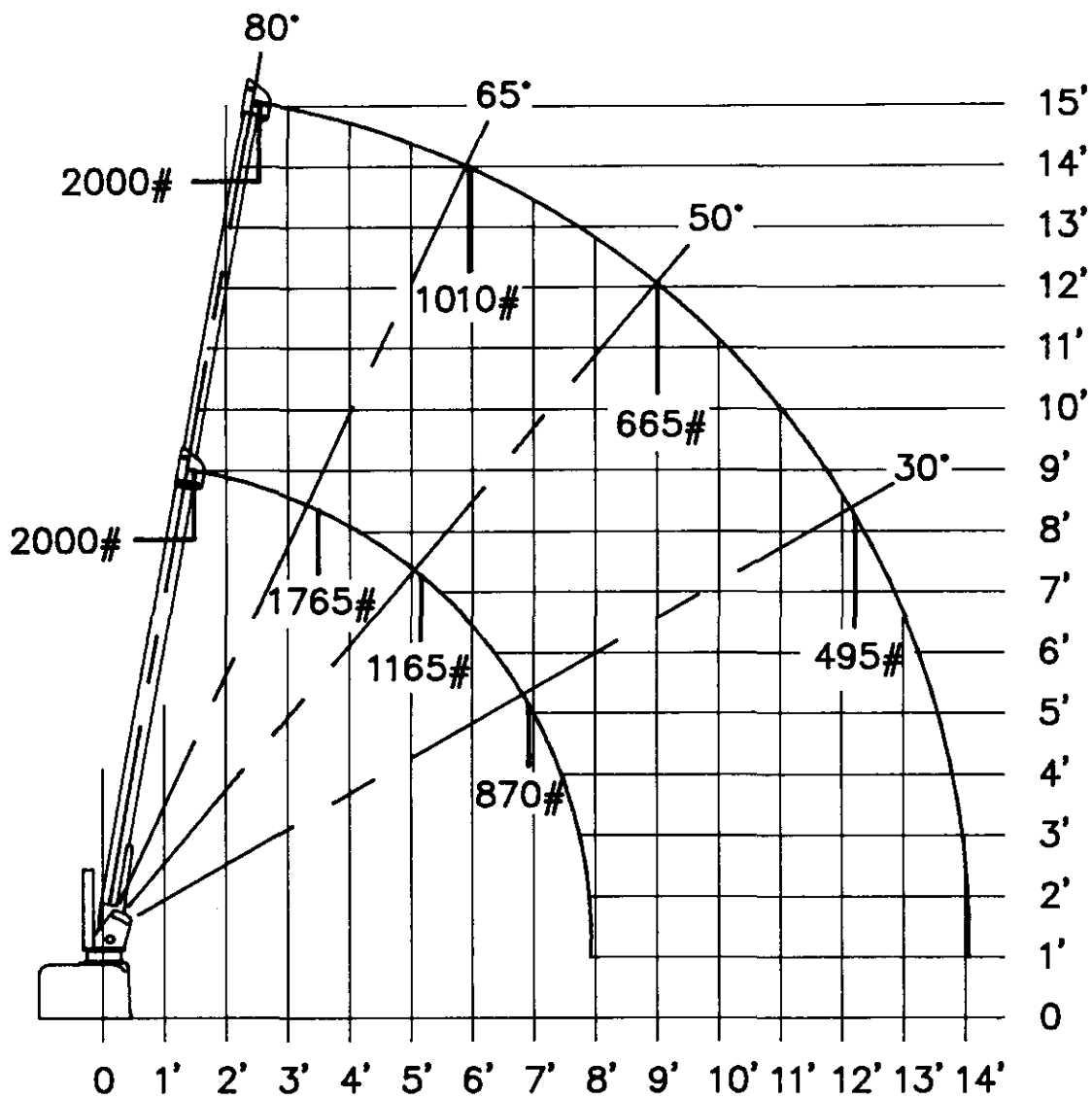

HORIZONTAL REACH IN FT
 CAPACITY IN POUNDS
 ALL LOADS OVER 1000 LBS USE DOUBLE LINE

P/N 330971

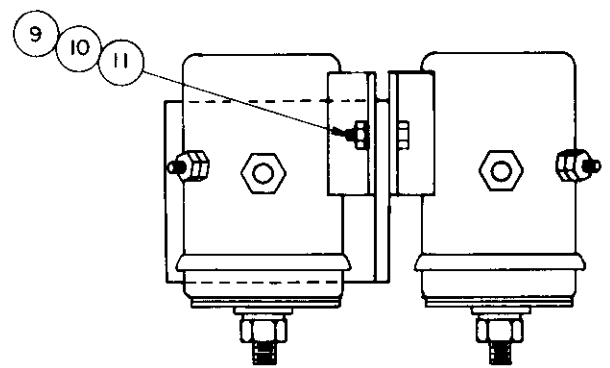
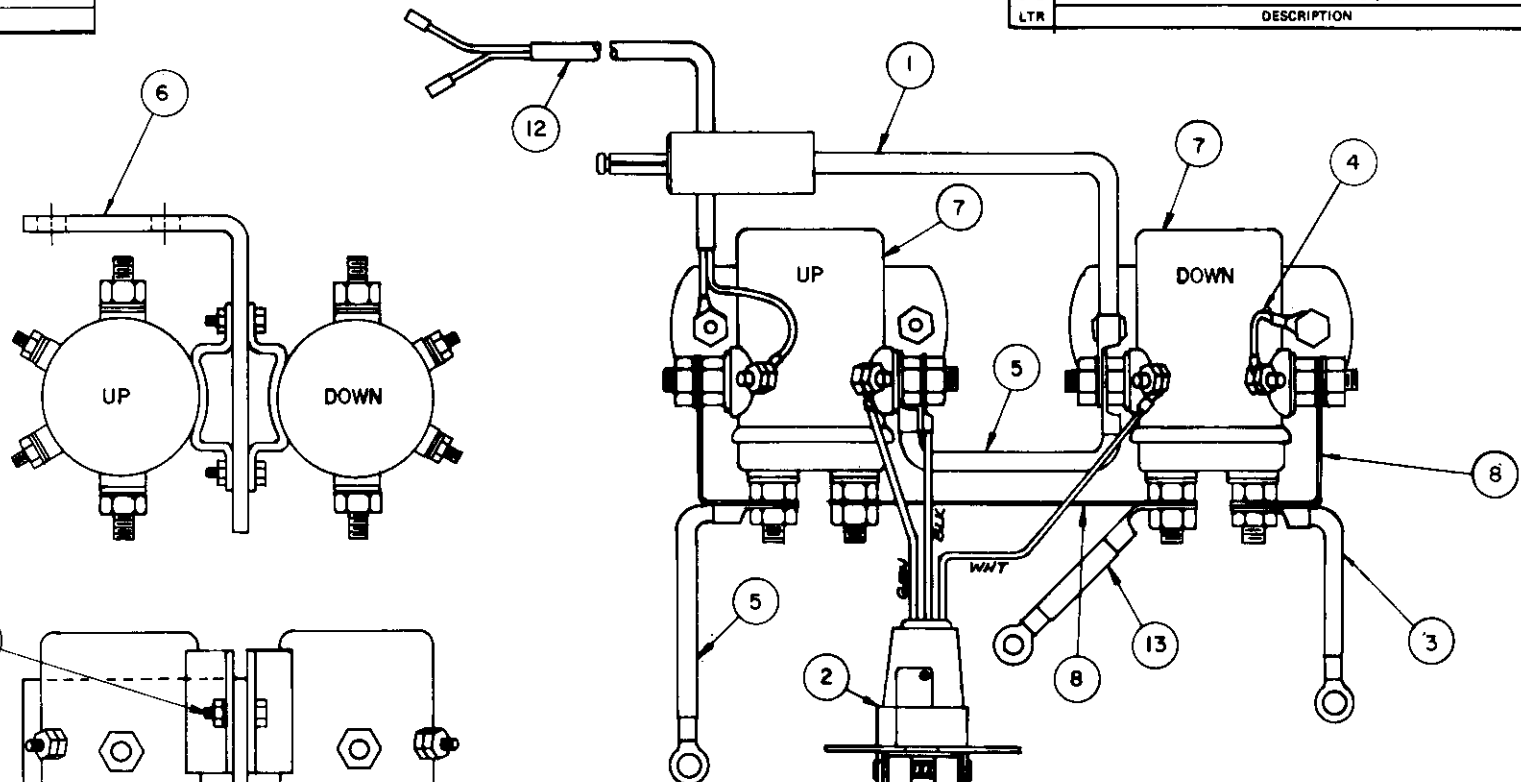

NOTE:
OMIT ITEM 12 IF LOAD SENSOR
IS NOT USED AND ADD ITEM 4.

13	1	600302	CONDUCTOR
12	1	330004	CONDUCTOR, CABLE
11	2	015900	NUT, 1/4-20
10	2	020200	WASHER, SPLK. 1/4
9	2	005500	SCREW, 1/4-20 X 3/4"
8	3	658300	CONDUCTOR, RELAY
7	2	200182	RELAY, 12V.
6	1	300037	BRACKET, RELAY
5	2	600303	CONDUCTOR
4	1	659904	CONDUCTOR
3	1	600306	CONDUCTOR
2	1	676400-001	PLUG ASSEMBLY
1	1	629617	CONDUCTOR

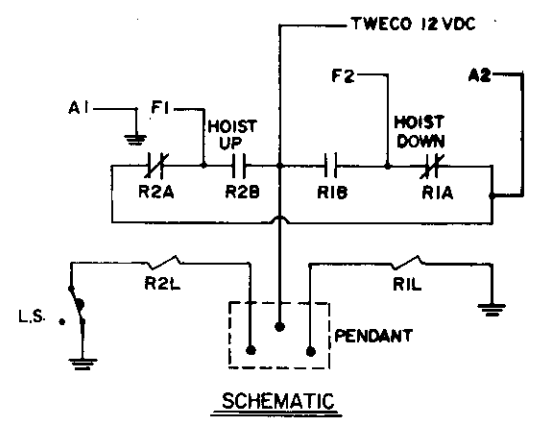

SCHEMATIC

ITEM	QTY	D/S	PART NO.	DESCRIPTION
LIST OF MATERIAL				
AUTO CRANE COMPANY				
P.O. BOX 48648 • TULSA, OKLAHOMA 74145 8280 BROKEN ARROW EXPRESSWAY • 918-627-9475				
UNLESS OTHERWISE NOTED ALL DIMENSIONS ARE IN INCHES. TOLERANCES UNLESS OTHERWISE SPECIFIED.			DRAWN BY DATE	
ANGLES ± 1/2° .XX ± .40			CHK'D BY	
FRACTIONAL ± 1/16 .XXX ± .010			DATE	
REMOVE ALL BURRS AND SHARP EDGES. DO NOT SCALE THIS DRAWING.			ENG. BY	
TOLERANCES NOT SHOWN ABOVE ARE PER ANSI Y14.5 - 1973			DATE	
THIS PRINT IS THE PROPERTY OF AUTO CRANE CO. AND MUST NOT BE USED IN ANY MANNER DETRIMENTAL TO THEIR INTERESTS.			SCALE	
NEXT ASS'Y			SIZE C	
			DRAWING NO. AW-330411	
			REVISION	
			WEIGHT	
			SHEET <u>1</u> OF <u>1</u>	

5-1.0.0

5-2.0.0

FIXTURE NO.	FINISH NO.	CHG	REVISIONS	
		LTR	DESCRIPTION	DATE APP'D

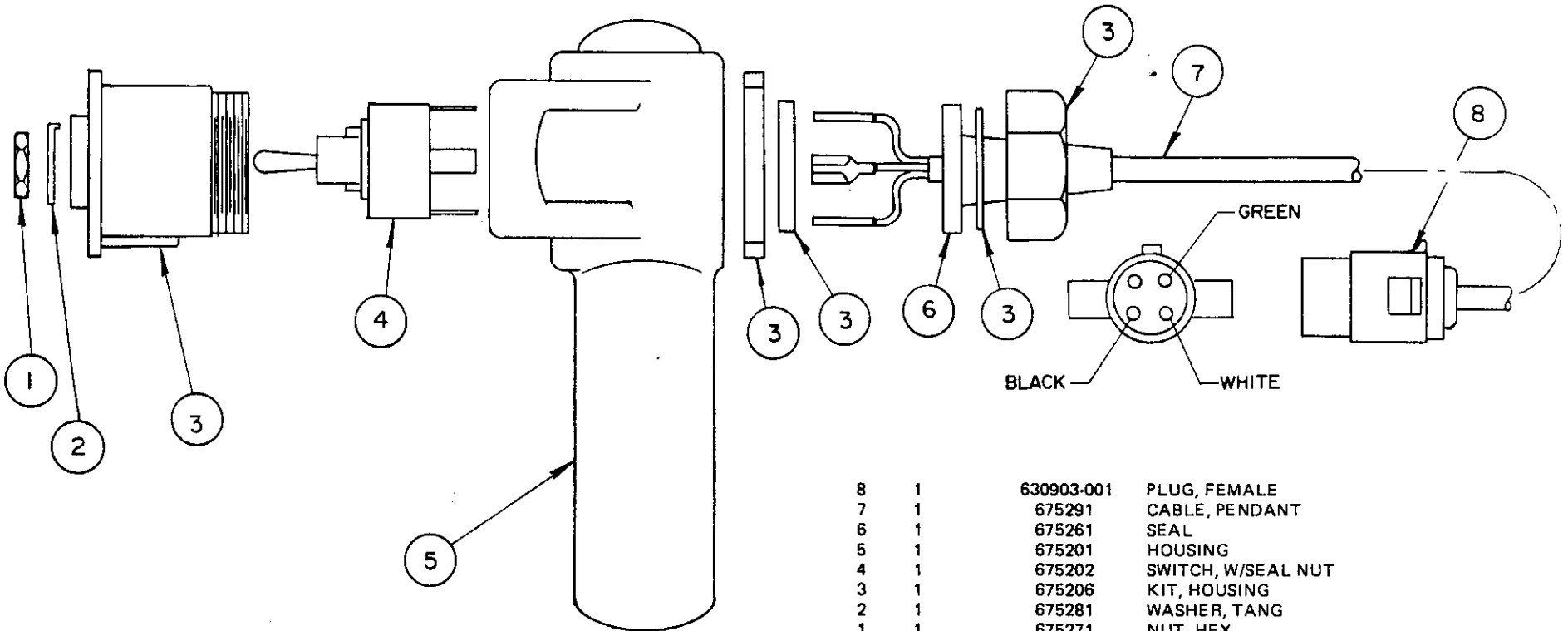

8	1	630903-001	PLUG, FEMALE
7	1	675291	CABLE, PENDANT
6	1	675261	SEAL
5	1	675201	HOUSING
4	1	675202	SWITCH, W/SEAL NUT
3	1	675206	KIT, HOUSING
2	1	675281	WASHER, TANG
1	1	675271	NUT, HEX.

- NOTES:
1. IF NEW PENDANT WITHOUT PLUG IS REQUIRED, USE P/N 675200 WHEN ORDERING.
 2. ITEM 3 MUST BE ORDERED AS AN ASSEMBLY.

ITEM	QTY	D/S	PART NO.	DESCRIPTION
LIST OF MATERIAL				
UNLESS OTHERWISE NOTED ALL DIMENSIONS ARE IN INCHES. TOLERANCES UNLESS OTHERWISE SPECIFIED.			AUTO CRANE COMPANY P.O. BOX 45548 • TULSA, OKLAHOMA 74145 9260 BROKEN ARROW EXPRESSWAY • 918-627-9475	
ANGLES ± 1/2° .XX ± .				
FRACTIONAL ± 1/16 .XXX ± .010				
REMOVE ALL BURRS AND SHARP EDGES. DO NOT SCALE THIS DRAWING.				
TOLERANCES NOT SHOWN ABOVE ARE PER ANSI Y14.5-1973			TITLE PENDANT, HOIST CONTROL	
THIS PRINT IS THE PROPERTY OF AUTO CRANE CO. AND MUST NOT BE USED IN ANY MANNER DETRIMENTAL TO THEIR INTERESTS.			SCALE	SIZE
NEXT ASS'Y			~	B
			DATE	DRAWING NO.
				AW-675205
			WEIGHT	REVISION
			SHEET 1 OF 1	

TROUBLESHOOTER 2003 SERIES

PROBLEM

CRANE WILL NOT HOIST UP.
CRANE WILL NOT HOIST DOWN.

CAUSE

Bad relay, crane not grounded properly, or power cable not connected to 12V power source. Bad switch in pendant, broken wire in pendant connector, pendant not plugged together properly, wire on relay not in proper place or lead wires to motor not connected properly.

SOLUTION

Problems can be solved by replacing bad relay, grounding the crane properly to the truck chassis, connecting the power cable properly to 12V+ power source, switch in pendant can be replaced, cord in remote control can be replaced, check connector on cord to make sure of contact of all the prongs on it are plugged together correctly, make sure wires on relays are according to the wiring print supplied with each new crane in the owner book and also wires going to motor are connected properly.

WITH LOAD SENSOR (OPT.)

PROBLEM

CRANE WILL NOT HOIST UP.

CAUSE

Crane is overloaded.
Sensor switch is bad.
Bad connection to relays.

SOLUTION

Hoist down. Do not overload crane. Replace sensor switch. Check for loose or damaged wiring.

PROBLEM

CRANE RUNS UP OR DOWN ANY TIME
POWER SOURCE IS CONNECTED.

CAUSE

Relay stuck in run position which will let crane run up or down any time 12V power source is connected. Wires shorted together in remote control. Lead or cable can also cause this problem. Wires jumped across relay in wrong place can cause crane to run all the time.

SOLUTION

Problem can be solved by checking the relays and replacing the bad one or removing jumper wires from the relays or replacing the remote control cord or switch.

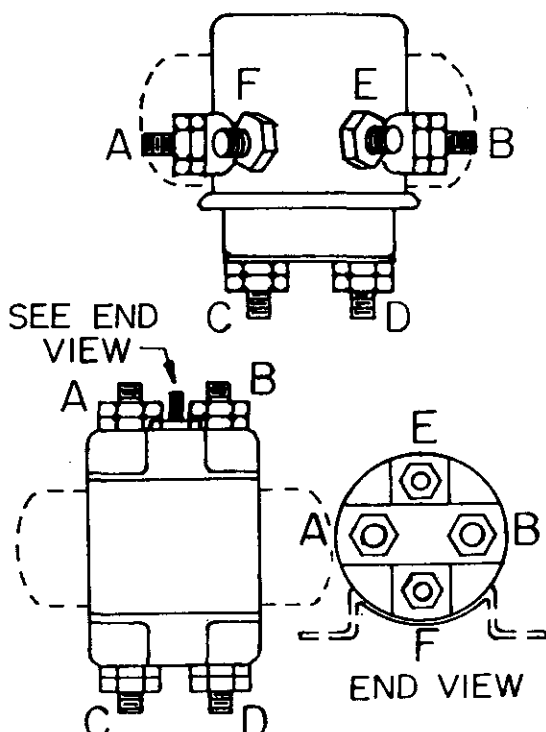

HOW TO CHECK RELAY:

To check a relay on this or any Auto Crane product is the same. The difference being in physical appearance. Shown at left are two types of relays Auto Crane uses. Our relays are normally closed across the bottom posts (C & D). When activated, they will open across (C & D) and close across (A & B). To activate these relays, use 12V positive and 12V negative wires and place them on posts (F & E). You may place 12V+ on post F or E as long as you place 12V on the remaining post (F & E) using an ohm meter or test light. Check across posts (A & B). You should get an ohm reading or your test light should be on when you have the relay activated. With the relay still activated, check across posts (C & D). You should have no ohm reading or test light at this point with relay activated. (At this point, disconnect 12V+ and 12V- from posts (F & E). This should let relay return to its normal position. Using your ohm meter or test light again, check the relay across posts (A & B). If relay is working correctly, you should have no reading at all. Then check across posts (C & D). You should have an ohm reading or test light should be on. If you get the above results, relay is okay. If you get any variation in the above explanation on the relay you are checking, check the relay again. If it still shows a difference, the relay is bad and should be replaced.

NOTE: The above explanation is with relays completely disconnected from all wires on motor circuits and ground wires. These circuits can give you false readings sometimes.



AUTO CRANE COMPANY

P. O. BOX 581510 • TULSA, OKLAHOMA 74158

Limited Warranty

Auto Crane will warranty to consumer for a period of twelve months from date of purchase that each new Auto Crane product it sells will be free under normal use and service, from defects in material and workmanship. Date of purchase will be honored as either date of purchase by distributor or his date of sale of the product as substantiated by Distributor Delivery Report.

Obligation of Auto Crane under this warranty is limited to replacement or repair of parts that appear to manufacturer after review and / or inspection to be defective. This warranty does not obligate Auto Crane to bear the cost of labor or transportation charges in connection with the replacement or repair of defective parts. Responsibility for customer's claims arising from misapplication, abuse, misuse or alteration of equipment or parts lies with the distributor or user and no warranty obligation is assumed in the circumstances by Auto Crane.

Auto Crane will in no event be liable for any consequential damages or contingent liabilities arising out of the failure of any Auto Crane product or parts to operate properly.

Auto Crane makes no warranty in respect to component accessories, same being subject to the warranties of their respective manufacturers.

If field service, at the request of buyer, is rendered and fault is found not to be with Auto Crane's product, the buyer shall pay the time and expense of the field representative. Claims for service labor or other expenses that have been incurred by the buyer without approval or authorization of Auto Crane will not be accepted.

AUTO CRANE COMPANY IS UNDER NO OBLIGATION TO EXTEND THIS WARRANTY TO ANY CUSTOMER FOR WHICH AN AUTO CRANE WARRANTY REGISTRATION CARD HAS NOT BEEN COMPLETED AND MAILED TO AUTO CRANE COMPANY WITHIN FIFTEEN (15) DAYS AFTER DATE OF PURCHASE.