

OWNERS MANUAL

2703 SERIES

REVISION 2/2000

PART NO. 999949

SERIAL NO. _____

AUTO CRANE COMPANY

PO BOX 580697, TULSA, OK 74158-0697

4707 N. MINGO ROAD, TULSA, OK 74117

PHONE (918) 836-0463

SALES FAX (918) 438-6688 SERVICE FAX (918) 834-5979

<http://www.autocrane.com>

!! DISTRIBUTORS !!

**PROTECT YOUR CUSTOMER'S WARRANTY!
SUBMIT DELIVERY REPORT WITHIN 15 DAYS.**

Mail to: Auto Crane Company
P.O. Box 580697
Tulsa, OK 74158-0697

Or Fax to: 918/834-5979

Protect your customers warranty - Submit within 15 days from delivery date.



AUTO CRANE COMPANY

**DISTRIBUTOR
DELIVERY REPORT**

DISTRIBUTOR _____		OWNER _____	
ADDRESS _____		CITY/STATE _____	
CITY/STATE/ZIP _____		BUSINESS _____	
MODEL #	SERIAL #	DATE DELIVERED	UNIT DESTINATION

IMPORTANT: ATTACH SIGNED COPY OF CUSTOMER INVOICE / DELIVERY RECEIPT

AC-109 REPORT AUTHORIZED BY: _____

*** REGISTER ONE UNIT ONLY PER CARD ***

WARNINGS - READ THIS PAGE!

WARNING! Federal law (49 cfr part 571) requires that the Final Stage Manufacturer of a vehicle certify that the vehicle complies with all applicable federal regulations. Any modifications performed on the vehicle prior to the final stage are also considered intermediate stage manufacturing and must be certified as to compliance. The installer of this crane and body is considered one of the manufacturers of the vehicle. As such a manufacturer, the installer is responsible for compliance with all applicable federal and state regulations, and is required to certify that the vehicle is in compliance.

WARNING! It is the further responsibility of the installer to comply with the OSHA Truck Crane Stability Requirements as specified by 29 CFR part 1910.180 (C) (1).

WARNING! NEVER OPERATE THE CRANE NEAR ELECTRICAL POWER LINES! Death or serious injury will result from boom, line, or load contacting electric lines. Do not use crane within 10 feet (3.05m) of electric power lines carrying up to 50,000 volts. One foot additional clearance is required for every additional 30,000 volts or less.

WARNING! NEVER

- v **EXCEED** load chart capacities (centerline of rotation to hoist hook).
- v un-reel last 5 wraps of cable from drum!
- v wrap cable around load!
- v attempt to lift or drag a load from the side! The boom can fail far below its rated capacity.
- v weld, modify, or use unauthorized components on any Auto Crane unit! This will void any warranty or liability. Also failure of the crane may result.
- v place a chain link on the tip of the hook and try to lift a load!
- v use a sling bar or anything larger than the hook throat that could prevent the hook latch from closing, thus negating the safety feature!
- v hold on any pendant Select Switch that will cause unsafe operating conditions!

WARNING! In using a hook with latch, **ALWAYS** make sure that the hook throat is closed before lifting a load! Proper attention and common sense applied to the use of the hoist hook and various slings will prevent possible damage to material being hoisted and may prevent injury to personnel.

WARNING! Failure to correctly plumb and wire crane can cause inadvertent operation and damage to crane and/or personnel!

WARNING! Auto Crane Company remote controlled cranes are not designed or intended to be used for any applications involving the lifting or moving of personnel.

WARNING! ALWAYS operate the crane in compliance with the load capacity chart. **Do not use** the overload shutdown device to determine maximum rated loads, if your crane is equipped with this type of device.



2703 SERIES - OWNER'S MANUAL
TABLE OF CONTENTS



	PAGE
1 INTRODUCTION	1-1.0.0
2 OPERATING PRACTICES & WARNINGS	1-2.0.0
3 OPERATION OF UNIT / OUTRIGGERS	1-3.0.0
4 QUALIFICATIONS FOR OPERATORS	1-4.0.0
5 INSPECTION, TESTING, & MAINTENANCE	1-5.0.0
6 LIFE OF WIRE LINE / WIRE LINE LUBRICATION	1-6.0.0
7 LUBRICATION & MAINTENANCE SCHEDULE	1-7.0.0
8 INSTALLATION	2-1.0.0
9 GENERAL ASSEMBLY	3-1.0.0
10 MANUAL BRAKE ASSEMBLY	3-4.0.0
11 TURNER ASSEMBLY	3-6.0.0
12 HOIST ACTUATOR ASSEMBLY	3-8.0.0
13 SAFETY DECAL SECTION	4-1.0.0
14 GENERAL DIMENSIONS	5-1.0.0
15 ELECTRICAL SECTION	6-1.0.0
16 RELAY ASSEMBLY	6-5.0.0
17 TROUBLESHOOTING	7-1.0.0
18 OUTRIGGERS	8-1.0.0
19 LOAD CHART	9-9.9.9
20 WARRANTY	LAST PAGE



INTRODUCTION

2703 SERIES

Auto Crane products have been engineered to provide safe, trouble-free, dependable service for many years when these products are properly used and maintained.

To assist you in obtaining the best service from your crane and to avoid untimely failure of the unit and / or the vehicle on which it is mounted, the following operating and service instructions are herein published, and it is specifically recommended that all operating and service personnel consider this manual as mandatory material for reading and study before operating or servicing Auto Crane products. It is highly recommended that crane owners, equipment managers and supervisors also read this manual.

For your convenience the overall dimensions of the 2703 series crane are on the General Dimension Drawing. Maximum turning radius is shown at the outside point of the hoist actuator (M model) and the outside edge of the rotation gear motor (MR & PR model).

Remember, the crane adds weight to the vehicle. Adding weight may change the driving and riding characteristics of the vehicle unless the appropriate overload spring(s) are installed on the truck. The payload of the vehicle is reduced by the weight of the crane. The operator should exercise care when loading the vehicle. Distributing the payload on the vehicle evenly will greatly improve the driving and riding characteristics of the vehicle. **A minimum G.V.W. of 8,000 lbs. with two rear jacklegs (or outriggers) is recommended for mounting the 2703 series cranes. Crane side jackleg should extend 45" from centerline of truck chassis.**

The 2703 series cranes are attached directly to your 12 volt truck electrical system. The power cable and retaining clips are included with the crane. A typical power cable

mounting and hookup is shown on page 2-1.0.0. The performance of your new crane depends on the truck electrical system. The use of the low maintenance battery is not recommended for use on any Auto Crane product. The recommended alternator and battery that will give the longest life with the most useful duty cycle is a 60 amp. alternator with a 500 cold cranking rated battery. These specifications should be considered minimum.

Auto Crane Company issues a limited warranty certificate with each unit sold. See last page for warranty policy.

It has always been Auto Crane Company policy to handle all warranty claims we receive as promptly as possible. If a warranty claim involves discrepant material or workmanship, Auto Crane will take immediate corrective action. It is understandable that Auto Crane company cannot assume responsibility of liability when it is obvious that our products have been abused, mis-used, overloaded or otherwise damaged by inexperienced persons trying to operate the equipment without reading the manual.

Auto Crane will not assume responsibility or liability for any modifications or changes made to unit, or installation of component parts done without authorization.

Auto Crane maintains a strong distributor network and a knowledgeable Customer Service Department. In most cases, an equipment problem is solved via phone conversation with our customer service department. The customer service department also has the ability to bring a local distributor, a regional sales manager, or a factory serviceman into the solution of an equipment problem. If, through no fault of Auto Crane Company, it is necessary to send an experienced factory



INTRODUCTION

2703 SERIES

serviceman on a field service call, the rates stated in the Auto Crane Distributor's Flat Rate Manual will apply.

Auto Crane Company's extensive Research and Development Program allow our customers to use the best equipment on the market. Our Engineering Staff and our knowledgeable sales people, are always available to our customers in solving crane and winch-type application problems. When in doubt, call the Auto Crane factory.

DISTRIBUTOR ASSISTANCE:

Should you require any assistance not given in this manual, we recommend that you consult your nearest Auto Crane Distributor. Our distributors sell authorized parts and have

service departments that can solve almost any needed repair.

***NOTE: THIS MANUAL
SHOULD REMAIN WITH
THE CRANE AT ALL TIMES.***

This manual does not cover all maintenance, operating, or repair instructions pertinent to all possible situations. If you require additional information, please contact the **Auto Crane Company** at the following telephone number: **(918) 438-2760**. The information contained in the manual is in effect at the time of this printing. Auto Crane Company reserves the right to update this material without notice or obligation.

GENERAL SPECIFICATIONS

2703 SERIES

DIMENSIONS

Width: [M]19.0 in (.48 m)
 [MR]21.5 in (.55m)
 [PR]21.5 in (.55m)

Height: 28.25 in (.72 m)

Length: 6 ft 11 in (2.11 m)
 [boom(s) stored]

Weight:

- M 6-10 365 lbs (166 kg)
- M 6-10-14 430 lbs (195 kg)
- MR 6-10 430 lbs (195 kg)
- MR 6-10-14 460 lbs (209 kg)
- PR 6-10 490 lbs (222 kg)
- PR 6-10-14 520 lbs (236 kg)
- [Add 5 lbs (2.25 kg) for cable length of 75 feet (23 m)]

CAPACITY

8,100 ft lbs (1.12 ton/m)
 [ft lbs = horizontal distance from centerline of rotation to free hanging weight (feet) x amount of weight (pounds)]

LIFTING CAPACITIES			
ft	lbs	ft	lbs
3	2,700	9	900
4	2,025	10	810
5	1,620	11	735
6	1,350	12	675
7	1,150	13	620
8	1,010	14	575

REACH

Second boom will reach from 6 ft to 10 ft
 Third boom will reach from 10 ft to 14 ft

CABLE

62 ft (18.9 m) of 7/32 in diameter aircraft quality cable is standard [75 ft (22.86 m) optional]. This cable has a single line breaking strength of 5600 lbs (2540 kg).

CHASSIS REQUIREMENTS

8,000 lbs (3,628 kg) GVWR minimum

ELECTRICAL SYSTEM

Hoist Motor: 12 volt DC series wound

Rotation Gearmotor: 12 volt DC, PM type

ELECTRICAL SYSTEM REQUIREMENTS

Alternator: 60 amp (minimum)

Battery: 100 minute reserve capacity (minimum)
 Maintenance type

ROTATION

- M model: 360° Continuous manual rotation
- MR model: 360° Continuous power rotation
- PR model: 360° Continuous power rotation

--- IMPORTANT ---

OPERATING PRACTICES & WARNINGS

1. Make certain the vehicle meets minimum chassis requirements. (These requirements do not guarantee unit stability)
2. Make certain the crane is installed per factory specifications. Contact your local Distributor or the Auto Crane factory if any questions arise.
3. Keep the vehicle in as level a position as possible while loading or unloading.
4. **ALWAYS** set the vehicle emergency brake before beginning crane operations.
5. **ALWAYS** use outriggers from vehicle to the ground during crane operation. Make sure they are firmly positioned on solid footings.
6. All load ratings are based on crane capacity, **NOT** truck/crane stability.
7. Keep objects and personnel clear of crane path during operation.
8. Keep hoist cable pulled tight at all times.
9. **REMEMBER**, in lifting a heavy load, the weight can create enough tipping momentum to overturn the vehicle.
10. **ALWAYS** keep load as close to ground as possible.
11. Oil gears as required.
12. Periodic adjustment of hoist worm brake may be required (see automatic safety brake drawing in this manual).
13. Hydraulic hoses need to be inspected frequently for signs of deterioration, and be replaced as required.
14. The hoist hook is an important item that an operator should consider and use properly. It should be checked on a daily basis for distortion or cracks.
15. **ALWAYS** store outriggers before road travel.
16. **WARNING! NEVER OPERATE THE CRANE NEAR ELECTRICAL POWER LINES!** Death or serious injury will result from boom, line, or load contacting electric lines. Do not use crane within 10 feet (3.05m) of electric power lines carrying up to 50,000 volts. One foot additional clearance is required for every additional 30,000 volts or less.
17. **WARNING! NEVER EXCEED** load chart capacities (centerline of rotation to hoist hook).
18. **WARNING! NEVER** un-reel last 5 wraps of cable from drum!
19. **WARNING! NEVER** wrap cable around load!
20. **WARNING! NEVER** attempt to lift or drag a load from the side! The boom can fail far below its rated capacity.
21. **WARNING! NEVER** weld, modify, or use unauthorized components on any Auto Crane unit! This will void any warranty or liability. Also failure of the crane may result.
22. **WARNING! NEVER** place a chain link on the tip of the hook and try to lift a load!
23. **WARNING! NEVER** use a sling bar or anything larger than the hook throat that could prevent the hook latch from closing, thus negating the safety feature!
24. **WARNING!** In using a hook with latch, **ALWAYS** insure that the hook throat is closed before lifting a load! Proper attention and common sense applied to the use of the hoist hook and various slings will prevent possible damage to material being hoisted and may prevent injury to personnel.
25. **WARNING! NEVER** hold any pendant Select Switch on that will cause unsafe operating conditions!

WARNING!

Auto Crane Company remote controlled, stiff boom cranes are not designed or intended to be used for any applications involving the lifting or moving of personnel.

--- IMPORTANT --- OPERATION OF UNIT

26. Make sure this manual has been thoroughly read by all crane operating personnel and supervisors.
27. A routine inspection of the crane should be mandatory before each operating day. Any defects should be corrected immediately.
28. At a job site the vehicle should be positioned so that the crane can adequately reach the load within the rated capacity (centerline of rotation to hoist hook).
29. Keep the vehicle as level as possible during operation.
30. For electric cranes, **engage emergency brake** and leave ignition on with transmission in neutral (or in park for automatic transmissions). Activate any crane power switches. For Auto Crane units requiring battery and hydraulic operation, **engage emergency brake**, place gear selector in neutral, press clutch, activate PTO, release clutch and after hydraulic fluid is warm, set throttle control to proper engine speed.
31. Always use outriggers from the truck to the ground. Be sure these are firm and adequately positioned. When rotating, **keep load as low to the ground as possible**.
32. Remove pendant control from cab or storage area. On smaller units, plug pendant into receptacle on crane. On larger units, remove pendant control from guard and unwrap cable from boom. Do not operate crane until cable is unwound completely. On all cranes, detach hook from dead man. Crane is now ready for operation.
33. Always boom up before rotating so the boom will clear the required boom support.
34. When extending the boom, always maintain clearance between the boom crown and the traveling block or hoist hook.
35. Always observe safe and practical operation to avoid possible accidents. Refer to Safety Tips and Precautions.
36. After completing lifting operations, return the boom to stowed position on the boom support. Avoid unneeded pressure on the boom support.
37. Store pendant control on proper location (in cab or on crane).
38. Return outriggers to stowed position. Make sure they are pinned in place or jacklegs are returned to compartment.
39. Check work area for any tools or equipment not stored.
40. Release throttle control, depress clutch and disengage PTO. Deactivate any crane power switches.
41. Report any unusual occurrence during crane operation that may indicate required maintenance or repair.
42. **NEVER** use two cranes to support a load too large for either crane.
43. Spray all electrical equipment with special corrosion resistant coating. This eliminates rust or corrosion due to melting and freezing action of condensation.

OPERATION OF OUTRIGGERS

For hydraulic outriggers:

1. Shift crane/outrigger control valve to "outrigger" position.
2. While operating the outrigger control valves (located on the outrigger cylinders) simultaneously operate the boom-up control switch. This will allow the hydraulic system to build pressure.
3. After outriggers are positioned, return crane/outrigger selector to "crane" position.
4. Crane is now ready to operate.

For manual outriggers:

1. Pull lock pins to release jack leg or drop down outrigger and move to outermost lock position.
2. Make sure lock pins are reinstalled properly.
3. Lower outrigger pad to firm ground and adjust foot to take out slack.
4. Crane is now ready to operate.

QUALIFICATIONS FOR AND CONDUCT OF OPERATORS AND OPERATING PRACTICES

OPERATORS

- 1 Crane operation shall be limited to personnel with the following minimum qualifications:**
 - A. designated persons
 - B. trainees under the direct supervision of a designated person
 - C. maintenance and test personnel (when it is necessary in the performance of their duties)
 - D. inspectors (crane).
- 2 No one other than the personnel specified above shall enter the operating area of a crane with the exception of persons such as oilers, supervisors, and those specified persons authorized by supervisors whose duties require them to do so and then only in the performance of their duties and with the knowledge of the operator or other persons.**

QUALIFICATIONS FOR OPERATORS

- 3 Operators shall be required by the employer to pass a practical operating examination. Qualifications shall be limited to the specific type of equipment for which examined.**
- 4 Operators and operator trainees shall meet the following physical qualifications:**
 - A. Vision of at least 20/30 Snellen in one eye and 20/50 in the other, with or without corrective lenses.
 - B. Ability to distinguish colors, regardless of position, if colors differentiation is required for operation.
 - C. Adequate hearing with or without hearing aid for the specific operation.
- 5 Evidence of physical defects or emotional instability which render a hazard to operator or others, which in the opinion of the examiner could interfere with the operator's performance may be sufficient cause for disqualification. In such cases, specialized clinical or medical judgment and tests may be required.**
- 6 Evidence that the operator is subject to seizures or loss of physical control shall be sufficient reason for disqualification. Specialized medical tests may be required to determine these conditions.**

- 7 Operators and operator trainees should have normal depth perception, coordination, and no tendencies to dizziness or similar undesirable characteristics.**
- 8 In addition to the above listed requirements, the operator shall:**
 - A. Demonstrate the ability to comprehend and interpret all labels, operator's manuals, safety codes and other information pertinent to correct crane operations.
 - B. Possess knowledge of emergency procedures and implementation of same.
 - C. Demonstrate to the employer the ability to operate the specific type of equipment.
 - D. Be familiar with the applicable safety regulations.
 - E. Understand responsibility for maintenance requirements of crane.
 - F. Be thoroughly familiar with the crane and its control functions.
 - G. Understand the operating procedures as outlined by the manufacturer.

CONDUCT OF OPERATORS

- 9 The operator shall not engage in any practice which will divert his attention while actually operating the crane.**
- 10 Each operator shall be responsible for those operations under the operator's direct control. Whenever there is any doubt as to safety, the operator shall consult with the supervisor before handling the loads.**
- 11 The operator should not leave a suspended load unattended unless specific precautions have been instituted and are in place.**
- 12 If there is a warning sign on the switch or engine starting controls, the operator shall not close the switch or start the engine until the warning sign has been removed by the appointed person.**
- 13 Before closing the switch or starting the engine, the operator shall see that all controls are in the "OFF" or neutral position and all personnel are in the clear.**
- 14 If power fails during operation, the operator shall:**
 - A. move power controls to the "OFF" or neutral position.

QUALIFICATIONS FOR AND CONDUCT OF OPERATORS AND OPERATING PRACTICES

B. land the suspended load and boom, if practical.

15 The operator shall be familiar with the equipment and its proper care. If adjustments or repairs are necessary, the operator shall report the same promptly to the appointed person, and shall also notify the next operator.

16 All controls shall be tested by the operator at the start of each shift. If any controls do not operate properly, they shall be adjusted or repaired before operations are begun.

17 Stabilizers shall be visible to the operator while extending or setting unless operator is assisted by a signal person.

OPERATING PRACTICES

HANDLING THE LOAD

18 Size of load

- A. No crane shall be loaded beyond the rated load except for test purposes.
- B. The load to be lifted is to be within the rated load of the crane and its existing configuration.
- C. When loads which are not accurately known are to be lifted, the person responsible for the job shall ascertain that the weight of the load does not exceed the crane rated load at the radius at which the load is to be lifted.

19 Attaching the load

- A. The load shall be attached to the hook by means of slings or other devices of sufficient capacity.
- B. Hoist rope shall not be wrapped around the load.

20 Moving the load

- A. The operator shall determine that:
- B. The crane is level and, where necessary, the vehicle/carrier is blocked properly.
- C. The load is well secured and balanced in the sling or lifting device before it is lifted more than a few inches.
- D. Means are provided to hold the vehicle stationary while operating the crane.
- E. Before starting to lift, the hook shall be brought over the load in such a manner as to minimize swinging.

F. During lifting care shall be taken that:

- 1. **there is no sudden acceleration or deceleration of the moving load.**
- 2. **load, boom or other parts of the crane do not contact any obstruction.**

G. Cranes shall not be used for dragging loads sideways.

H. This standard recognizes that articulating boom cranes are designed and intended for handling materials. They do not meet personnel lift or elevator requirements. Therefore, no lifting, lowering, swinging or traveling shall be done while a person is on the hook or load. Hook attached suspended work platforms (baskets) shall not be used with cranes covered by this standard. Work platforms attached to the boom must be approved by crane manufacturer.

I. The operator should avoid carrying loads over people.

J. When the crane is so equipped, the stabilizers shall be fully extended and set. Blocking under stabilizers shall meet the requirements as follows:

- 1. **strong enough to prevent crushing.**
- 2. **of such thickness, width and length as to completely support the stabilizer pad.**

K. Firm footing under all tires, or individual stabilizer pads should be level. Where such a footing is not otherwise supplied, it should be provided by timbers, cribbing, or other structural members to distribute the load so as to not exceed allowable bearing capacity or the underlying material.

L. In transit, the boom shall be carried in stowed position.

M. When rotating the crane, sudden starts and stops shall be avoided. rotational speed shall be such that the load does not swing out beyond the radius at which it can be controlled.

N. The crane shall not be transported with a load on the hook unless recommended by the manufacturer.

O. No person should be permitted to stand or pass under a suspended load.

21 Stowing procedure. Follow the manufacturer's procedure and sequence when stowing and un-stowing the crane.

QUALIFICATIONS FOR AND CONDUCT OF OPERATORS AND OPERATING PRACTICES

MISCELLANEOUS

OPERATING NEAR ELECTRICAL POWER LINES

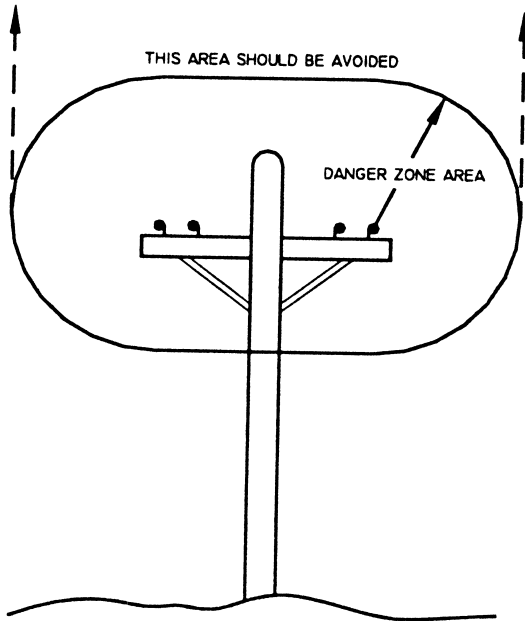

22 Cranes shall be operated so that no part of the crane or load enters into the danger zone shown above.

EXCEPTIONS

- A. The danger zone may be entered after confirmation by an appointed person that the electrical distribution and transmission lines have been de-energized and visibly grounded at the point of work; or
- B. The danger zone may be entered if insulating barriers (not a part of nor an attachment to the crane) have been erected to prevent physical contact with the lines.

23 For lines rated 50 kV or below, minimum clearance between the lines and any part of the crane or load (including handling appendages) shall be 10 ft. (3m). For higher voltages, see Table 1.

24 Caution shall be exercised when working near overhead lines, because they can move horizontally or vertically due to wind, moving the danger zone to new positions.

25 In transit with no load and boom lowered the clearance shall be specified in Table 1.

26 A qualified signalperson shall be assigned to observe the clearance and give warning before approaching the above limits.

- A. Any overhead wire shall be considered to be an energized line unless and until the person owning such line or the electrical utility authorities verify that it is not an energized line.
- B. Exceptions to this procedure, if approved by the administrative or regulatory authority if the alternate procedure provides equivalent protection and set forth in writing.
- C. Durable signs shall be installed at the operator's station and on the outside of the crane, warning that electrocution or serious bodily injury may occur unless a minimum clearance of 10 ft. (3.0m) between the crane or the load being handled and energized power lines. Greater clearances are required because of higher voltage as stated above. These signs shall be revised but not removed when local jurisdiction requires greater clearances.

TABLE 1

normal voltage, kV (phase to phase)		minimum required clearance	
		ft	(m)
<u>when operating near high voltage power lines</u>			
over	to 50	10	(3.05)
over	50 to 200	15	(4.6)
over	200 to 350	20	(6.1)
over	350 to 500	25	(7.62)
over	500 to 750	35	(10.67)
over	750 to 1000	45	(13.72)
<u>while in transit with no load and boom lowered</u>			
over	to 0.75	4	(1.22)
over	0.75 to 50	6	(1.83)
over	50 to 345	10	(3.83)
over	345 to 750	16	(4.87)
over	750 to 1000	20	(6.1)

INSPECTION, TESTING AND MAINTENANCE

GENERAL

INSPECTION CLASSIFICATION

27 Initial inspection. Prior to initial use, all new, altered, modified or extensively repaired cranes shall be inspected by a designated person to insure compliance with provisions of this standard.

28 Regular inspection. Inspection procedure for cranes in regular service is divided into two general classifications based upon the intervals at which inspection should be performed. The intervals in turn are dependent upon the nature of the components of the crane and the degree of their exposure to wear, deterioration, or malfunction. The two general classifications are herein designated as "frequent" and "periodic" with respective intervals between inspections as defined below.

- A. frequent inspection - daily to monthly intervals
- B. periodic inspection - one to twelve intervals, or as specifically recommended by the manufacturer

FREQUENT INSPECTION

29 Inspection shall be performed by designated personnel.

- A. control mechanisms for maladjustment interfering with proper operation - daily, when used
- B. control mechanisms for excessive wear of components and contamination by lubricants or other foreign matter
- C. safety devices for malfunction
- D. all hydraulic hoses, particularly those which flex in normal operation of crane functions, should be visually inspected once every working day, when used
- E. hooks and latches for deformation, chemical damage, cracks, and wear. Refer to ANSI/ASME B30.10
- F. rope reeving for compliance with crane manufacturer's specifications, if optional winch is used

G. electrical apparatus for malfunctioning, signs of excessive deterioration, dirt and moisture accumulation

H. hydraulic system for proper oil level and leaks daily

I. tires for recommended inflation pressure, cuts and loose wheel nuts

J. connecting pins and locking device for wear and damage

PERIODIC INSPECTION

30 Deformed, cracked or corroded members in the crane structure and carrier.

31 Loose bolts, particularly mounting bolts.

32 Cracked or worn sheaves and drums.

33 Worn, cracked, or distorted parts such as pins, bearings, shafts, gears, rollers and devices.

34 Excessive wear on brake and clutch system parts and lining.

35 Crane hooks inspected for cracks.

36 Travel steering, braking, and locking devices, for malfunction.

37 Excessively worn or damaged tires.

38 Hydraulic and pneumatic hose, fittings, and tubing inspection.

A. evidence of leakage at the surface of the flexible hose or its junction with metal and coupling

B. blistering, or abnormal deformation to the outer covering of the hydraulic or pneumatic hose

C. leakage at threaded or clamped joints that cannot be eliminated by normal tightening or recommended procedures

D. evidence or excessive abrasion or scrubbing on the outer surface of a hose, rigid tube, or fitting. Means shall be taken to eliminate the interference of

INSPECTION, TESTING AND MAINTENANCE

GENERAL

elements in contact or otherwise protect the components

necessary to determine origin of the problem before corrective action can be taken.

39 Hydraulic and pneumatic pumps and motors inspection.

- A. loose bolts or fasteners
- B. leaks at joints between sections
- C. shaft seal leaks
- D. unusual noises or vibrations
- E. loss of operating speed
- F. excessive heating of the fluid
- G. loss of pressure

40 Hydraulic and pneumatic valves inspection.

- A. cracks in valve housing
- B. improper return of spool to neutral position
- C. leaks at spools or joints
- D. sticking spools
- E. failure of relief valves to attain or maintain correct pressure setting
- F. relief valve pressure shall be checked as specified by the manufacturers

41 Hydraulic and pneumatic cylinders inspection.

- A. drifting caused by fluid leaking across piston
- B. rod seals leaking
- C. leaks at welding joints
- D. scored, nicked, or dented cylinder rods
- E. damaged case (barrel)
- F. loose or deformed rod eyes or connecting joints

42 Hydraulic filters. Evidence of rubber particles on the filter elements may indicate hose, "O" ring, or other rubber component deterioration. Metal chips or pieces on the filter may denote failure in pumps, motors, or cylinders. Further checking will be

43 Labels are to be in place and legible.

CRANES NOT IN REGULAR USE

44 A crane which has been idle for a period of over one month or more, but not less than six months, shall be given an inspection conforming with the initial-regular- frequent inspections.

45 A crane which has been idle for a period of over six months shall be given a complete inspection conforming with the initial-regular-frequent inspection requirements.

INSPECTION RECORDS

46 Dated records for periodic inspection should be made on critical items such as brakes, crane hooks, rope, hydraulic and pneumatic cylinders, and hydraulic and pneumatic relief pressure valves. Records should be kept available to an appointed person.

OPERATIONAL TESTS

47 Prior to initial use, all new, altered, modified, or extensively repaired cranes shall be tested for compliance with the operational requirements of this section, including functions such as the following:

- A. load lifting and lowering mechanisms
- B. boom lifting and lowering mechanisms
- C. boom extension and retraction mechanisms
- D. swing mechanisms
- E. safety devices
- F. operating controls comply with appropriate function labels

Operational crane test results shall be made available to an appointed person.

RATED TEST LOAD

Prior to initial use, altered, modified, or extensively repaired cranes shall be load

INSPECTION, TESTING AND MAINTENANCE

GENERAL

tested by or under the direction of an appointed person.

48 Test loads shall not exceed 110% of the manufacturer's load ratings.

49 Written reports shall be maintained showing test procedures and confirming the adequacy of repairs.

MAINTENANCE

PREVENTIVE MAINTENANCE

50 Before adjustment and repairs are started on a crane, the following precautions shall be taken as applicable:

- A. crane placed where it will cause the least interference with other equipment or operations
- B. all controls at the "off" position
- C. starting means rendered inoperative
- D. boom lowered to the ground if possible or otherwise secured against dropping
- E. relieve hydraulic oil pressure from all hydraulic circuits before loosening or removing hydraulic components

51 Warning or "OUT OF ORDER" signs shall be placed on the crane controls.

52 After adjustments and repairs have been made, the crane shall not be returned to service until all guards have been reinstalled, trapped air removed from hydraulic system (if required), safety devices reactivated, and maintenance equipment removed.

ADJUSTMENTS AND REPAIRS

53 Any hazardous conditions disclosed by the inspection requirements shall be corrected before operation of crane is resumed, Adjustments and repairs shall be done only by designated personnel.

54 Adjustments shall be maintained to assure correct functioning of components, The following are examples:

- A. functional operating mechanism
- B. safety devices
- C. control systems

55 Repairs or replacements shall be provided as needed for operation.

The following are examples:

- A. critical parts of functional operating mechanisms which are cracked, broken, corroded, bent, or excessively worn
- B. critical parts of the crane structure which are cracked, bent, broken, or excessively corroded
- C. crane hooks showing cracks, damage, or corrosion shall be taken out of service. Repairs by welding are not recommended

56 Instructions shall be provided by the manufacturer for the removal of air from hydraulic circuits.

LUBRICATION

All moving parts of the crane, for which lubrication is specified, should be regularly lubricated per the manufacturer's recommendations and procedures.

ROPE INSPECTION

57 Frequent Inspection

- A. All running ropes in service should be visually inspected once each working day. A visual inspection shall consist of observation of all rope which can be in use during the days operations. These visual observations should be considered with discovering gross damage such as listed below, which may be an immediate hazard.

- 1. distortion of the rope such as kinking, crushing, un-stranding, birdcaging, main strand displacement, or core protrusion. Loss of rope diameter in a short length or unevenness of outer strands should be replaced**

- 2. general corrosion**

INSPECTION, TESTING AND MAINTENANCE

GENERAL

3. broken or cut strands;
4. number, distribution and type of visible broken wires. When such damage is discovered, the rope shall either be removed from service or given as inspection.

B. Care shall be taken when inspecting sections of rapid deterioration such as flange points, crossover points, and repetitive pickup points on drums.

58 Periodic inspection

A. The inspection frequency shall be determined by a qualified person and shall be based on such factors as:

1. expected rope life as determined by experience on the particular installation or similar installations
2. severity of environment
3. percentage of capacity lifts
4. frequency rates of operation
5. exposure to shock loads

Inspection need not be at equal calendar intervals and should be more frequent as the rope approaches the end of its service life. This inspection shall be made at least annually.

B. Periodic inspection shall be performed by a designated person. This inspection shall cover the entire length of the rope. Only the surface wires need be inspected. No attempt should be made to open the rope. Any deterioration results in appreciable loss of original strength, such as described below, shall be noted and determination made as to whether use of the rope would constitute a hazard: points listed above reduction of rope diameter below nominal diameter due to loss of core support, internal or external corrosion, or wear of outside wires; severely corroded, cracked, bent, worn or improperly applied connections;

C. Care shall be taken when inspecting sections subject to rapid deterioration such as the following:

1. sections in contact with saddles, equalizer sheaves, or other sheaves where rope travel is limited
2. sections of the rope at or near terminal ends where corroded or broken wires may protrude

ROPE REPLACEMENT

59 No precise rules can be given for determination of the exact time for replacement of rope, since many variable factors are involved.

Continued use in this respect depends upon good judgement by a designated person in evaluating remaining strength in a used rope after allowance for deterioration disclosed by inspection. Continued rope operation depends upon this remaining strength.

60 Conditions such as the following shall be reason for questioning continued use of the rope or increasing the frequency of inspection:

- A. in running ropes, six randomly distributed broken wires in one lay or three broken wires in one strand in one lay
- B. one outer wire broken at the contact point with the core of the rope structure and protrudes or loops out of the rope structure. Additional inspection of this section is required
- C. wear of one third of the original diameter of the outside individual wire
- D. kinking, crushing, birdcaging, or any other damage resulting in distortion of the rope structure
- E. evidence of any heat damage from any cause
- F. reduction from nominal diameter of more than 1/64 in. (0.4mm) for diameters up to and including 5/16 in. (8 mm), 1/32 in. (0.8 mm) for diameter 3/8 in. (9.5 mm) to and including 1/2 in. (13 mm), 3/64 in. (1.2 mm) for diameter 9/16 in. (14.5 mm) to and including 3/4 in. (19 mm). 1/16 in. (1.6 mm) for diameter 7/8 in. (22 mm) to and including 11/8 in. (29 mm), 3/32 in. (2.4 mm) for diameters 11/4 in. (32 mm) to and including 11/2 in. (38 mm)

INSPECTION, TESTING AND MAINTENANCE

GENERAL

G. In standing ropes, more than two broken wires in one lay in sections beyond end connections or more than one broken wire at an end connection.

H. Replacement rope shall have a strength rating at least as great as the original rope furnished or recommended by the crane manufacturer. Any deviation from the original size, grade, or construction shall be specified by a rope manufacturer, or a qualified person.

61 Rope not in regular use: all rope which has been idle for a period of a month or more due to shutdown or storage of a crane on which it is installed, shall be given and inspection in accordance with above information before it is placed in service. This inspection shall be for all types of deterioration and shall be performed by a qualified person.

62 Inspection records

A. frequent inspection- no records required

B. periodic inspections- in order to establish data as a basis for judging the proper time for replacement, a dated report condition at each periodic inspection should be kept on file. This report shall cover points of deterioration listed above.

ROPE MAINTENANCE

63 Rope should be stored to prevent damage or deterioration.

64 Unreeling or uncoiling of rope shall be done as recommended by the rope manufacturer and with care to avoid kinking or inducing twist.

65 Before cutting a rope, seizing shall be placed on each side of the place where the rope is to be cut to prevent unlaying of the strands. On pre-formed rope, one seizing on each side of the cut is required. On non-preformed ropes of 7/8 in. (22 mm) diameter or smaller, two seizings on each side of the cut are required, and for non-preformed rope 1 in. (25 mm) diameter or larger, three seizings on each side of the cut are required.

66 During installation care should be exercised to avoid dragging of the rope in the dirt or around objects which will scrape, nick crush or induce sharp bends in it.

67 Rope should be maintained in a well-lubricated condition. It is important that lubricant applied as a part of a maintenance program shall be compatible with the original lubricant and to this end the rope manufacturer should be consulted. Lubricant applied shall be the type which does not hinder visual inspection. Those sections of rope which are located over sheaves or otherwise hidden during inspection and maintenance procedures require special attention when lubricating rope. The object of rope lubrication is to reduce internal friction and to prevent corrosion.

68 When an operating rope shows greater wear or well defined localized areas than on the remainder of the rope, rope life can be extended in cases where a section at the worn end, and thus shifting the wear to different areas of the rope.

MAINTENANCE OF BATTERIES

Maintenance of Auto Crane unit batteries differs very little from the generally prescribed maintenance of any lead acid battery. All batteries must be kept *properly charged, properly filled with water, and relatively clean.*

Keep Properly Charged

Many things affect the proper charge to a battery, such as:

- 1 Regulator settings
- 2 Proper tightness of belts on the alternator or generator
- 3 Good, clean connections of all cables and wires at the following places:
 - A. Battery
 - B. Regulator
 - C. Starting motor
 - D. Alternator or generator
 - E. Ground connections (most important)

It is of extreme importance to keep the battery as fully charged as possible without overcharging, especially when vehicles are left outside for extended periods in extremely cold climates. A battery *can* freeze. Freezing points for various specific gravities of acid are as follows:

Specific Gravity (Corrected to 80°F)	Freezing Temp. Degrees F.
1.280	-90°F
1.250	-62°F
1.200	-16°F
1.150	5°F
1.100	19°F

As shown, a half-charged battery (about 1.200 specific gravity) cannot stand for any length of time at 20°F or it will freeze.

The *main reason* for keeping the battery as fully charged as possible without over-charging is to ensure that power is available even though the vehicle has been standing for some time.

Keep Properly Filled with Water

The battery should *always* be properly filled with water. If the electrolyte level is allowed to fall below the top of the plates, the results become threefold:

- 1 The exposed portion of the plate will become sulfated.
- 2 The portion of the plate exposed is not usable.
- 3 That portion of the acid remaining becomes more concentrated and may cause more rapid deterioration of the remaining parts of the battery.

Keep A Relatively Clean Battery

The battery should be kept clean. Batteries filled with acid and which are not in use self-discharge to a limited degree because of the nature of the materials within the battery. If dirt is allowed to collect on the top of the battery (and this dirt absorbs moisture) and electrical path can be set up between the various terminals of the battery and the ground. Once such a path has been established, the self-discharge of the battery is accelerated. This also accelerates corrosion of the battery cables at the terminals.

Periodic Maintenance is Needed

A definite program of periodic maintenance of all batteries should be conducted on a regular basis. Periodic maintenance includes:

- 1 Checking belts for tightness on the charging equipment
- 2 Checking battery electrolyte levels
- 3 Checking cables for good connections
- 4 Cleaning where corrosion is apparent

When corrosion is cleaned off, the cable terminals and battery terminals should be coated with a light coating of petroleum jelly before they are replaced. When terminals are cleaned, the top of the battery should be cleaned with a mild solution of soda water.

MAINTENANCE OF BATTERIES

Low Maintenance Batteries (Maintenance Free)

Low maintenance batteries should not be used on Auto Cranes or trucks equipped with Auto Cranes. The batteries are not designed for "deep" discharge.

Testing Your Battery

If the condition of the battery is in question, it should be removed from the vehicle, taken to the shop, and allowed to reach room temperature. It should then be recharged until specific gravity readings taken at one-half hour intervals. If the specific gravity readings are fairly uniform, the battery should be checked with a high rate tester. Use the tester in accordance with the manufacturer's instructions. The high rate tester is the best method to test a questionable battery.

If, after charging, it is noted that the specific gravity reading of one cell is 30 points less than any of the other cells, it may be assumed that the cell is bad and that the battery should be replaced. If all cells are uniform but not up to full charge, a low rate of charge

should be attempted for an extended time. This usually will recover a badly sulfated battery.

Replacing a Battery

If it is necessary to replace a battery, and a dry charge battery is used, the following procedure applies:

- 1 Fill the battery with electrolyte of the proper specific gravity.
- 2 Place the battery on charge according to the manufacturer's instructions.

It is essential that the second step above be followed to ensure that the battery going on the vehicle is fully charged.

It is also very important that the battery hold-downs be checked periodically to ensure that the batteries are properly positioned to avoid vibration problems, breakage of cables or terminals. Care must be taken to avoid cracking or breaking containers or covers by tightening hold-down fixtures excessively. They also must not be so loose that breakage results from a hold-down that is too loose.

LIFE OF WIRE LINE

So many variable factors can cause the deterioration of wire line cable that it is not possible to determine a definite life expectancy. Some of these factors are:

- **Load being handled.**
- **Corrosive conditions.**
- **Maintenance of the unit:**
 - Keep the sheaves turning freely.
 - Maintain tension on cable to insure proper spooling.
 - Avoid kinks in cable.
 - Avoid abrasive action and contact with sharp corner.
- **Frequency of use.**

Auto Crane units, up to 2,400 pound ratings use 3/16 inch diameter galvanized pre-formed 7 x 19 aircraft cable. This cable has a working strength, when new, of 4,200 pounds. It is recommended when 1,200 pound loads are exceeded to use a two part line with a traveling block. This will ensure a 3.5 to 1 safety factor when the cable is new.

Keeping the above factor of safety in mind and knowing the kind of loads that will be handled, the user can determine by inspection of the cable as to when it should be replaced.

Items to look for while inspecting the cables are:

- Broken strands.
- Kinks and flattened sections.
- Corrosion and abrasion.

WIRE LINE LUBRICATION

Lubrication of the wire line serves two important purposes:

- Prevent corrosion.
- Reduce wear due to flexing and abrasion caused by contact with the sheaves, rollers, and cable on the drum.

Preparation

Remove rust and foreign matter with a wire brush and wipe clean. Be sure cable is dry.

Application

Method 1: Dip a brush into a light weight motor oil and apply. In some cases, dip a rag or a piece of sheepskin into the lubricant and swab the lubricant on to the rope.

Method 2: Apply a heavier lubricant such as a grease gun lubricant with hands while wearing leather gloves. (Leather gloves give greater protection and less penetration of the grease than canvas gloves.)

LUBRICATION & MAINTENANCE SCHEDULE 2703 CRANE

SERVICE PERFORMED	DAY	WEEK	MONTH	6 MOS	YEAR	NOTES
LOAD HOOK	X					INSPECT HOOK & LATCH FOR DEFORMATION, CRACKS, & CORROSION
CABLE DRUM	X					MAKE SURE CABLE IS WOUND EVENLY ON DRUM
HOIST CABLE	X					CHECK FOR FLATTENING, KINKS, & BROKEN STRANDS, SEE MANUAL
MOUNTING BOLTS		X				CHECK-TORQUE TO 85 FT-LBS (DRY) AS REQUIRED
MOTOR CONNECTION		X				CHECK TERMINALS FOR TIGHT CONNECTIONS
SHEAVE BEARINGS		X				SEALED BEARING, REPLACE IF ROUGH OR LOOSE
ALL OTHER BOLTS		X				CHECK-TIGHTEN AS REQUIRED
BOOM CYLINDER		X				CHECK AROUND CYLINDER ROD FOR EXCESS FLUID LEAKAGE
BOOM CYLINDER PINS		X				GREASE WITH MOBILPLEX EP-2 OR EQUIVALENT @ ZERKS
BATTERY CONNECTIONS		X				CHECK FOR CORROSION & TIGHT CONNECTIONS. CLEAN & COAT AS REQUIRED
ROTATION BRAKE (M)		X				CHECK ADJUSTMENT
SAFETY DECALS			X			INSPECT AND REPLACE AS NEEDED
POWER CABLE			X			CHECK INSULATION FOR DAMAGE OR DETERIORATION
ROTATION GEAR (MR) (PR)			X			WATER PROOF BEARING GREASE OR DRY MOLYLUBE IF DUSTY CONDITIONS
ROTATION WORM BEARINGS (MR) (PR)				X		GREASE WITH MOBILPLEX EP-2 OR EQUIVALENT @ ZERKS
HOIST GEARBOX				X		WORM GEAR-EP GEAR LUBE SAE 80-90, SPUR GEAR SAE 30 OIL
HYDRAULIC FLUID					X	DRAIN, FLUSH, & REFILL WITH MOBIL DTE 13, OR EQUIVALENT
ROTATION BEARINGS	SEALED BEARING-NO MAINTENANCE REQUIRED					

LUBRICATION & MAINTENANCE SCHEDULE 2703 CRANE

BOOM SLIDE PADS	PADS GREASED WHEN REPLACED
FOR ADDITIONAL INFORMATION SEE:	1) OWNER'S MANUAL 2) OSHA SECTION 1910.180 3) ANSI B30.5-1989

CAUTION

vRoutine maintenance insures trouble-free operation and protects your investment. All warranties are void if maintenance is neglected.

NOTES:

- { Use only authorized parts. Any damage or malfunction caused by the use of unauthorized parts is not covered by Warranty or Product Liability.
- { Once a bolt has been torqued to its rated capacity and then removed; the bolt should be replaced with a new one.
- { Auto Crane Company recommends that this crane be serviced per “Crane Inspection Log” P/N 999978. These logs should be filled in at the intervals noted and kept as a permanent record. Additional copies are available from your local distributor.

ASSEMBLY & INSTALLATION INSTRUCTIONS

2703 SERIES

NOTE: For mounting bolt hole pattern - see page 5-1.0.0.

NOTE:
FOR MOUNTING BOLT HOLE
PATTERN - SEE GENERAL
DIMENSION DRAWING AW-631.

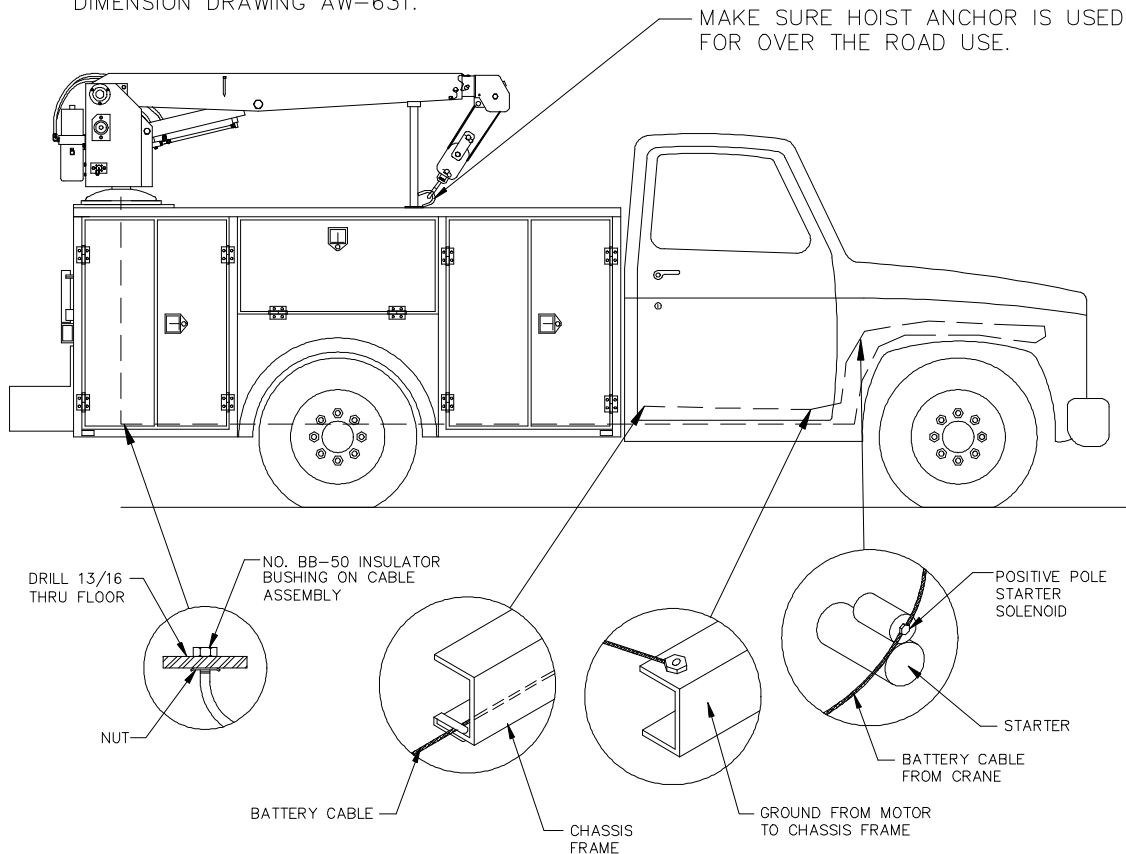

INSTALLATION - BATTERY CABLE

1. Drill 13/16" hole in floor. Install bushing, which is connected to cable, so it fits hole snug.
2. Run cable to positive battery terminal. Connect black cable to negative battery terminal or suitable chassis ground point. Locate cables so that they will be protected. Avoid sharp edges. Use the No. 083800 frame clips provided to hold cables securely in place.
3. If the battery is grounded to the engine it may be necessary to add an additional ground cable from the engine to the chassis frame to obtain maximum power at crane

BOOM SUPPORT

2703 SERIES

WARNING:

As with all Auto Crane power rotation units, the 2703 does require a boom support.

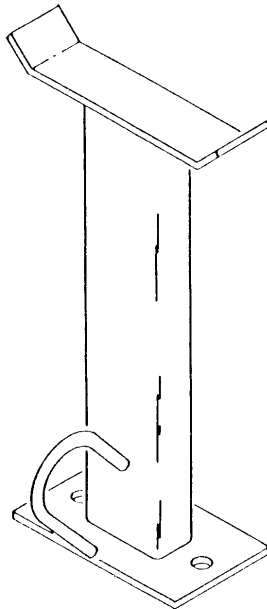

**Suggested Boom Support:
Auto Crane P/N 725045**

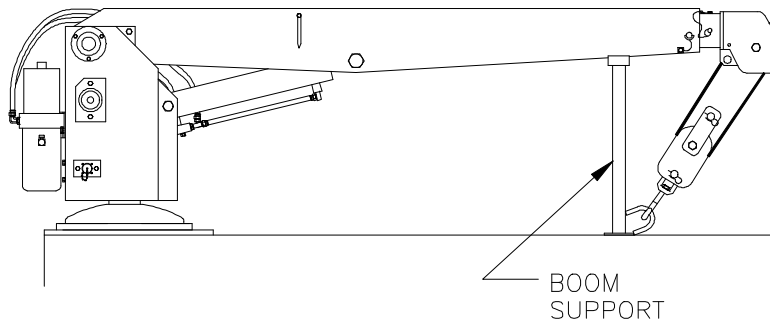

GENERAL ASSEMBLY

P/N 270300 - 2703 M, 6-10-14 BOOM

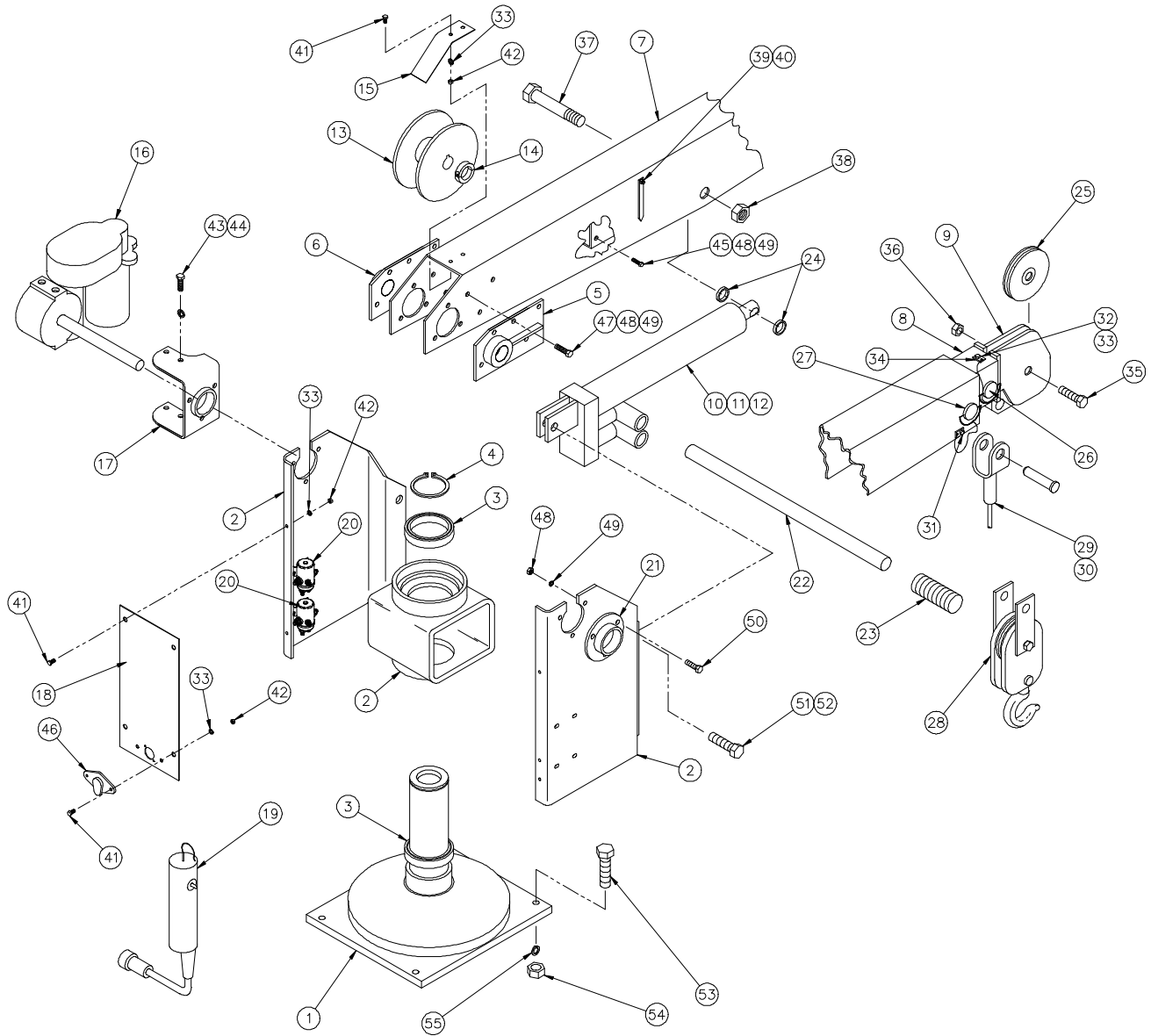

GENERAL ASSEMBLY

P/N 270300 - 2703 M, 6-10-14 BOOM

<u>ITEM</u>	<u>QTY</u>	<u>P/N</u>	<u>DESCRIPTION</u>
1	1	270432	QUILL / BASE
2	1	270419	QUILL HOUSING WELDMENT
3	2	330192	SEALED BALL BEARING
4	1	330182	SNAP RING
5	1	330471	RIGHT PIVOT BOOM
6	1	330471-001	LEFT PIVOT BOOM
7	1	270380	LOWER WELDMENT BOOM
8	1	270408	MID BOOM
9	1	320423	MANUAL BOOM w/ CROWN
10	1	270325	HYDRAULIC CYLINDER
11	1	270325-001	SEAL KIT (FOR 270325 CYL)
12	1	270325-002	REPAIR KIT (FOR 270325 CYL)
13	1	320379	DRUM
14	2	330468	COLLAR SP LK
15	1	270389	CABLE GUARD
16	1	320324	ACTUATOR ASSEMBLY
17	1	270403	ACTUATOR BRACKET
18	1	270391	REAR PANEL
19	1	330519	PENDANT CONTROL
20	1	270404	RELAY ASSEMBLY
21	1	330470	BEARING FLANGE
22	1	270325-006	PUMP HANDLE
23	1	270325-007	GRIP HANDLE
24	2	340303	SPACER
25	1	227401	SHEAVE ASSEMBLY (BEARING ONLY 200100)
26	1	370002	POSITION PIN
27	1	320328	LONG POSITION PIN
28	1	320433	TRAVELING BLOCK
29	1	320338	62' STANDARD CABLE ASSEMBLY
30	1	320339	75' OPTIONAL CABLE ASSEMBLY
31	1	002614	SCREW HEX HD 5/16-18 x 5/8 SELF-TAP
32	1	005501	SCREW HEX HD 1/4-28 NC x 3/4
33	7	020200	WASHER SP LK 1/4
34	1	320415	RETAINER MANUAL BOOM
35	1	012200	SCREW HEX HD 5/8-18 NF x 1 3/4 GR5
36	1	018100	NUT HEX HALF-LOCK 5/8-18 NF
37	1	330185	SCREW HEX HD 1-12 NF x 5 1/2 GR5
38	1	019106	NUT HEX 1-12 NF

GENERAL ASSEMBLY

P/N 270300 - 2703 M, 6-10-14 BOOM

<u>ITEM</u>	<u>QTY</u>	<u>P/N</u>	<u>DESCRIPTION</u>
39	1	360038	ANGLE INDICATOR
40	1	016300	NUT HEX LOCK 1/4-20 NC
41	5	005500	SCREW HEX HD 1/4 NC x 3/4
42	5	015900	NUT HEX 1/4-20 NC
43	4	007807	SCREW HEX HD 5/16-18 NC x 3/4
44	4	020600	WASHER SP LK 5/16
45	1	008401	SCREW HEX HD 3/8 NC x 1/2
46	1	REF	RECEPTACLE ASSEMBLY (<i>see RELAY ASSEMBLY</i>)
47	12	330370	SCREW HEX HD 3/8-16 NC x 7/8
48	19	330372	NUT HEX 3/8-16 NF
49	19	021100	WASHER SP LK 3/8
50	6	330371	SCREW HEX HD 3/8-16 NC x 1 GR8
51	1	014400	SCREW HEX HD 3/4-16 NC x 5 GR5
52	1	018600	NUT HEX LOCK 3/4-16 NF
53	4	011200	SCREW HEX HD 1/2-20 NF x 2 1/2 GR5
54	4	017704	NUT HEX 1/2-20 NF HEAVY
55	4	021500	WASHER SP LK 1/2

GENERAL ASSEMBLY

P/N 270302 - 2703 MR, 6-10-14 BOOM

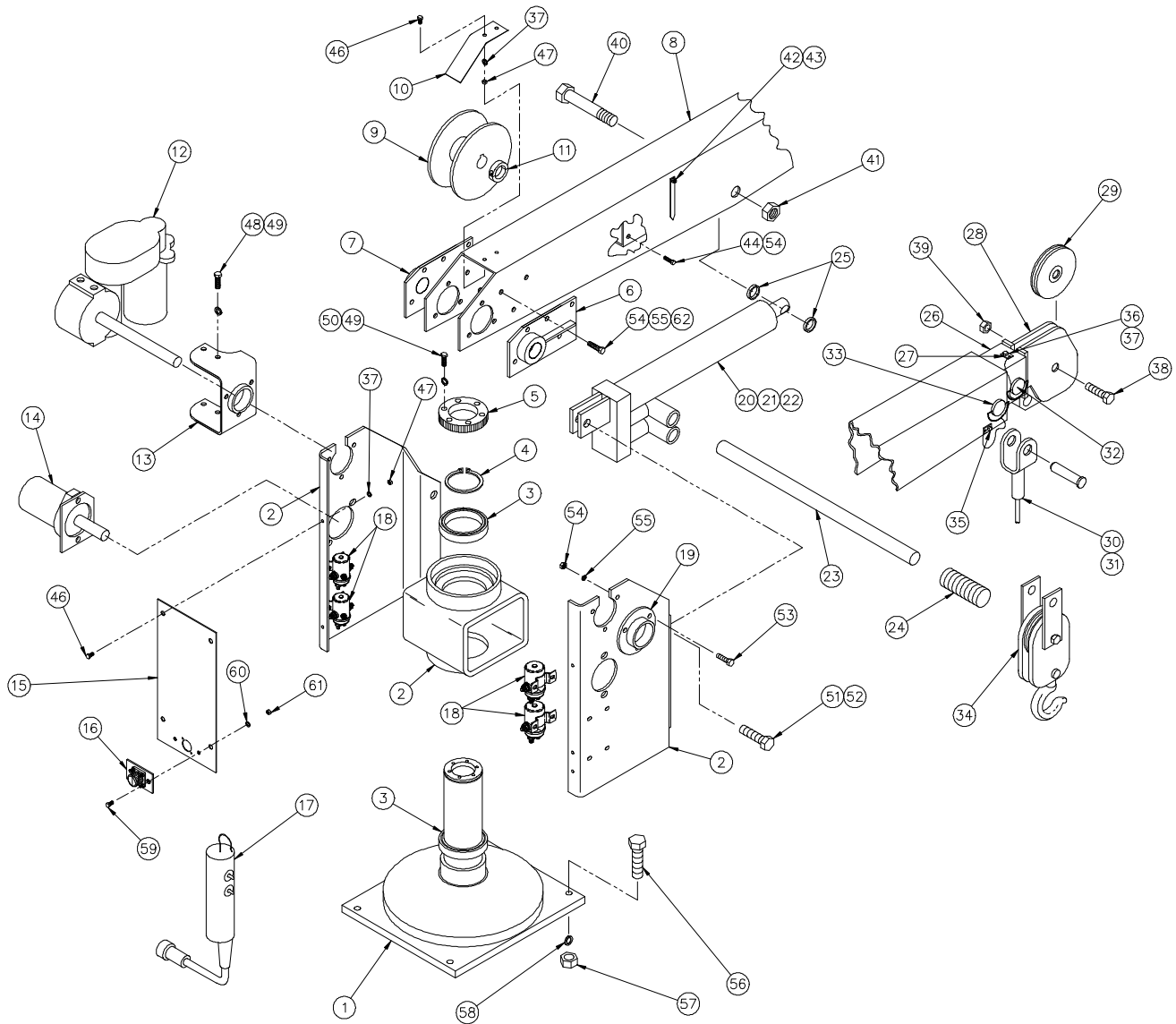

GENERAL ASSEMBLY

P/N 270302 - 2703 MR, 6-10-14 BOOM

<u>ITEM</u>	<u>QTY</u>	<u>P/N</u>	<u>DESCRIPTION</u>
1	1	270432	QUILL / BASE
2	1	270419	QUILL HOUSING WELDMENT
3	2	330192	SEALED BALL BEARING
4	1	330182	SNAP RING
5	1	270385	WORM GEAR
6	1	330471	RIGHT PIVOT BOOM
7	1	330471-001	LEFT PIVOT BOOM
8	1	270380	LOWER WELDMENT BOOM
9	1	320379	DRUM
10	1	270389	CABLE GUARD
11	2	330468	COLLAR SP LK
12	1	320324	ACTUATOR ASSEMBLY (see page 3-8.0.0)
13	1	270403	ACTUATOR BRACKET
14	1	330313	12V MOTOR GEAR
15	1	270391	REAR PANEL
16	1	REF	RECEPTACLE ASSEMBLY (see RELAY ASSEMBLY)
17	1	680068	PENDANT CONTROL (see page 6-2.0.0)
18	1	680052	RELAY ASSEMBLY (see page 6-5.0.0)
19	1	330470	BEARING FLANGE
20	1	270325	HYDRAULIC CYLINDER
21	1	270325-001	SEAL KIT (FOR 270325 CYLINDER)
22	1	270325-002	REPAIR KIT (FOR 270325 CYLINDER)
23	1	270325-006	PUMP HANDLE
24	1	270325-007	HANDLE GRIP
25	2	340303	SPACER
26	1	270408	MID MANUAL BOOM
27	1	320415	RETAINER MANUAL BOOM
28	1	320423	MANUAL BOOM w/ CROWN
29	1	227401	SHEAVE ASSEMBLY (BEARING ONLY 200100)
30	1	320338	62' STANDARD CABLE ASSEMBLY
31	1	320339	75' OPTIONAL CABLE ASSEMBLY
32	1	370002	PIN ASSEMBLY w/ LANYARD
33	1	320328	POSITION PIN (LONG)
34	1	320433	TRAVELING BLOCK
35	1	002614	SCREW HEX HD 5/16-18 NF x 5/8 SELF-TAP
36	1	005501	SCREW HEX HD 1/4-28 NF x 3/4
37	3	020200	WASHER SP LK 1/4
38	1	012200	SCREW HEX HD 5/8-18 NF x 1 3/4 GR5

GENERAL ASSEMBLY

P/N 270302 - 2703 MR, 6-10-14 BOOM

<u>ITEM</u>	<u>QTY</u>	<u>P/N</u>	<u>DESCRIPTION</u>
39	1	018100	NUT HEX HALF-LOCK 5/8-18 NF
40	1	330185	SCREW HEX HD 1-12 NF x 5 1/2 GR 5
41	1	019106	NUT HEX 1-12 NF
42	1	360038	ANGLE INDICATOR
43	1	016300	NUT HEX LOCK 1/4-20 NC
44	1	008401	SCREW HEX HD 3/8 NC x 1/2
45	-	-	-
46	3	005500	SCREW HEX HD 1/4-20 NC x 3/4
47	3	015900	NUT HEX 1/4-20 NC
48	4	007807	SCREW HEX HD 5/16-18 NC x 3/4
49	10	020600	WASHER SP LK 5/16
50	6	007805	SCREW HEX HD 5/16-18 NC x 1 1/2 GR5
51	1	014400	SCREW HEX HD 3/4 NF x 5 GR5
52	1	018600	NUT HEX 3/4-16 NF
53	6	330371	SCREW HEX HD 3/8-16 NC x 1 GR8
54	19	330372	NUT HEX 3/8-16 NC
55	19	021100	WASHER SP LK 3/8
56	4	011200	SCREW HEX HD 1/2-20 NF x 2 1/2 GR5
57	4	17704	NUT HEX 1/2-20 NF HEAVY
58	4	21500	WASHER SP LK 1/2
59	2	404	SCREW RD HD #6-32 NC x 5/8
60	2	019600	WASHER SP LK #6
61	2	015400	NUT HEX #6-32 NC
62	12	330370	SCREW HEX HD 3/8-16 NC x 7/8

GENERAL ASSEMBLY

P/N 270304 - 2703 PR, 6-10-14 BOOM

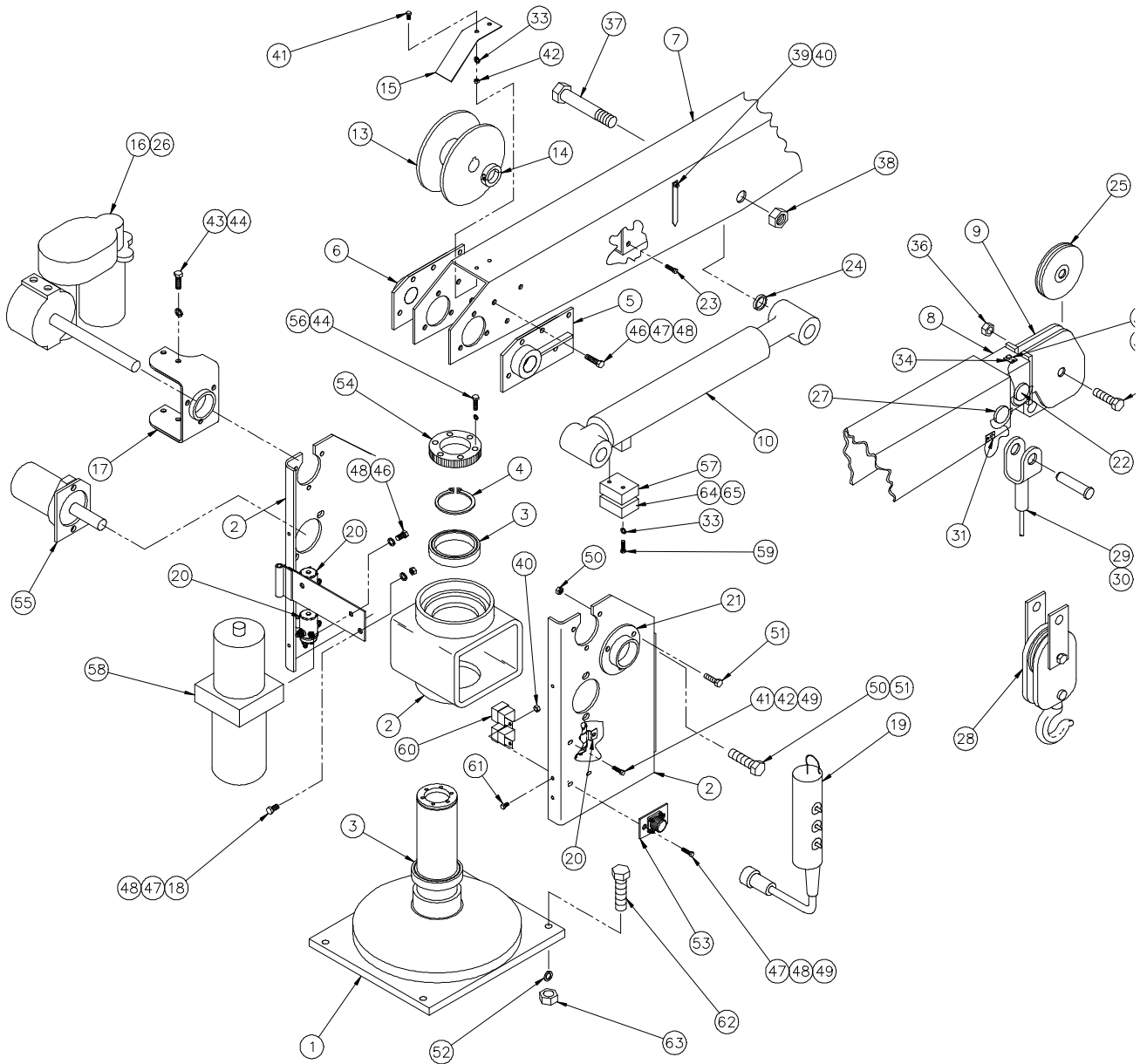

GENERAL ASSEMBLY

P/N 270304 - 2703 PR, 6-10-14 BOOM

<u>ITEM</u>	<u>QTY</u>	<u>P/N</u>	<u>DESCRIPTION</u>
1	1	270432	QUILL / BASE
2	1	270419	QUILL HOUSING WELDMENT
3	2	330192	SEALED BALL BEARING 5.9055 OD
4	1	330182	SNAP RING
5	1	330471	RIGHT PIVOT BOOM
6	1	330471-001	LEFT PIVOT BOOM
7	1	270380	LOWER BOOM WELDMENT
8	1	270408	MANUAL MID BOOM
9	1	320423	MANUAL BOOM w/ CROWN
10	1	330250	HYDRAULIC CYLINDER
11	1	270325-001	SEAL KIT FOR 270325 CYL (<i>not shown</i>)
12	1	270325-002	REPAIR KIT FOR 270325 CYL (<i>not shown</i>)
13	1	320379	CABLE DRUM
14	2	330468	COLLAR 1 1/4 ID
15	1	270389	CABLE GUARD
16	1	320324	ACTUATOR ASSEMBLY (<i>see page 3-8.0.0</i>)
17	1	270403	ACTUATOR BRACKET
18	1	008702	SCREW HEX HD 3/8 NC x 1 1/4
19	1	270410	PENDANT CONTROL (<i>see page 6-1.0.0</i>)
20	1	270416	RELAY ASSEMBLY (<i>see page 6-6.0.0</i>)
21	1	330470	BEARING FLANGE
22	1	370002	PIN ASSEMBLY w/ LANYARD
23	1	008401	SCREW HEX HD 3/8 NC x 1/2
24	2	340303	SPACER
25	1	227401	SHEAVE ASSEMBLY (BEARING ONLY 200100)
26	1	340523	KEY 1/4 x 1/4 x 2 3/4
27	1	320328	LONG POSITION PIN
28	1	320433	TRAVELING BLOCK (<i>see page 3-7.0.0</i>)
29	1	320338	62' STANDARD CABLE ASSEMBLY
30	1	320339	75' OPTIONAL CABLE ASSEMBLY
31	5	002614	SCREW HEX HD 5/16-18 x 5/8 SELF-TAP
32	1	005501	SCREW HEX HD 1/4-28 NC x 3/4
33	13	020200	LOCK WASHER 1/4
34	1	320415	RETAINER MANUAL BOOM
35	1	012200	SCREW HEX HD 5/8-18 NF x 1 3/4 GR8
36	1	018100	NUT HEX LOCK 5/8-18 NF
37	1	330185	SCREW HEX HD 1-12 NF x 5 1/2 GR5
38	1	019106	NUT HEX 1-12 NF

GENERAL ASSEMBLY

P/N 270304 - 2703 PR, 6-10-14 BOOM

<u>ITEM</u>	<u>QTY</u>	<u>P/N</u>	<u>DESCRIPTION</u>
39	1	360038	ANGLE INDICATOR
40	3	016300	NUT HEX LOCK 1/4-20 NC
41	8	005500	SCREW HEX HD 1/4 NC x 3/4
42	8	015900	NUT HEX 1/4-20 NC
43	4	007807	SCREW HEX HD 5/16-18 NC x 3/4
44	10	020600	LOCK WASHER 5/16
45	1	REF	TURNER ASSEMBLY (<i>not shown, see page 3-6.0.0</i>)
46	14	330370	SCREW HEX HD 3/8-16 NC x 7/8
47	22	330372	NUT HEX 3/8-16 NF
48	25	021100	LOCK WASHER 3/8
49	9	330371	SCREW HEX HD 3/8-16 NC x 1 GR8
50	2	018600	NUT HEX 3/4-16 NF
51	2	014400	SCREW HEX HD 3/4-16 NC x 1 GR8
*52	4	021500	LOCK WASHER
53	1	REF	RECEPTACLE ASSEMBLY (<i>see RELAY ASSEMBLY</i>)
54	1	270385	WORM GEAR
55	1	330313	12V MOTOR GEAR
56	6	007805	SCREW HEX HD 5/16-18 NC x 1 1/2 GR5
57	1	330412	HOLDING VALVE
58	1	270324	HYDRAULIC PUMP
59	2	006700	SCREW HEX HD 1/4 NC x 2 1/2
60	2	REF	RELAY DROP OUT
61	2	005604	SCREW HEX HD 1/4 NC x 1
*62	4	011200	SCREW HEX HD 1/2 NF 2 1/2 GR 5
*63	4	017704	NUT HEX 1/2 NF 20 GR 5
64	1	368985	MANIFOLD SENSE VALVE
65	1	241169	O-RING

*BASE MOUNTING HARDWARE TO TRUCK FRAME.

GENERAL ASSEMBLY

P/N 270301 - 2703 M, 6-10 BOOM

P/N 270303 - 2703 MR, 6-10 BOOM

P/N 270305 - 2703 PR, 6-10 BOOM

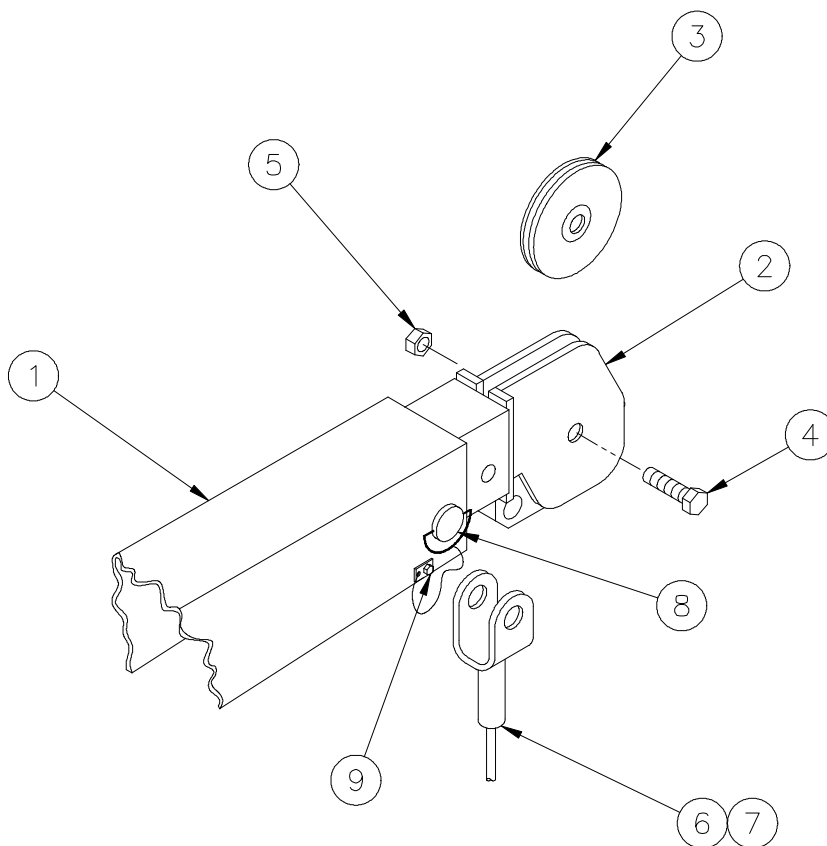

<u>ITEM</u>	<u>QTY</u>	<u>P/N</u>	<u>DESCRIPTION</u>
1	1	270380	LOWER BOOM WELDMENT
2	1	270402	MANUAL BOOM w/ CROWN
3	1	227401	SHEAVE ASSEMBLY (BEARING ONLY 200100)
4	1	012200	SCREW HEX HD 5/8 x 1 3/4 NF GR5
5	1	018100	LOCK NUT 5/8 NF
6	1	320338	62' STANDARD CABLE ASSEMBLY
7	1	320339	75' OPTIONAL CABLE ASSEMBLY
8	1	320328	POSITION PIN
9	1	002614	SCREW HEX HD 5/16 ST

BRAKE ASSEMBLY

2703 M

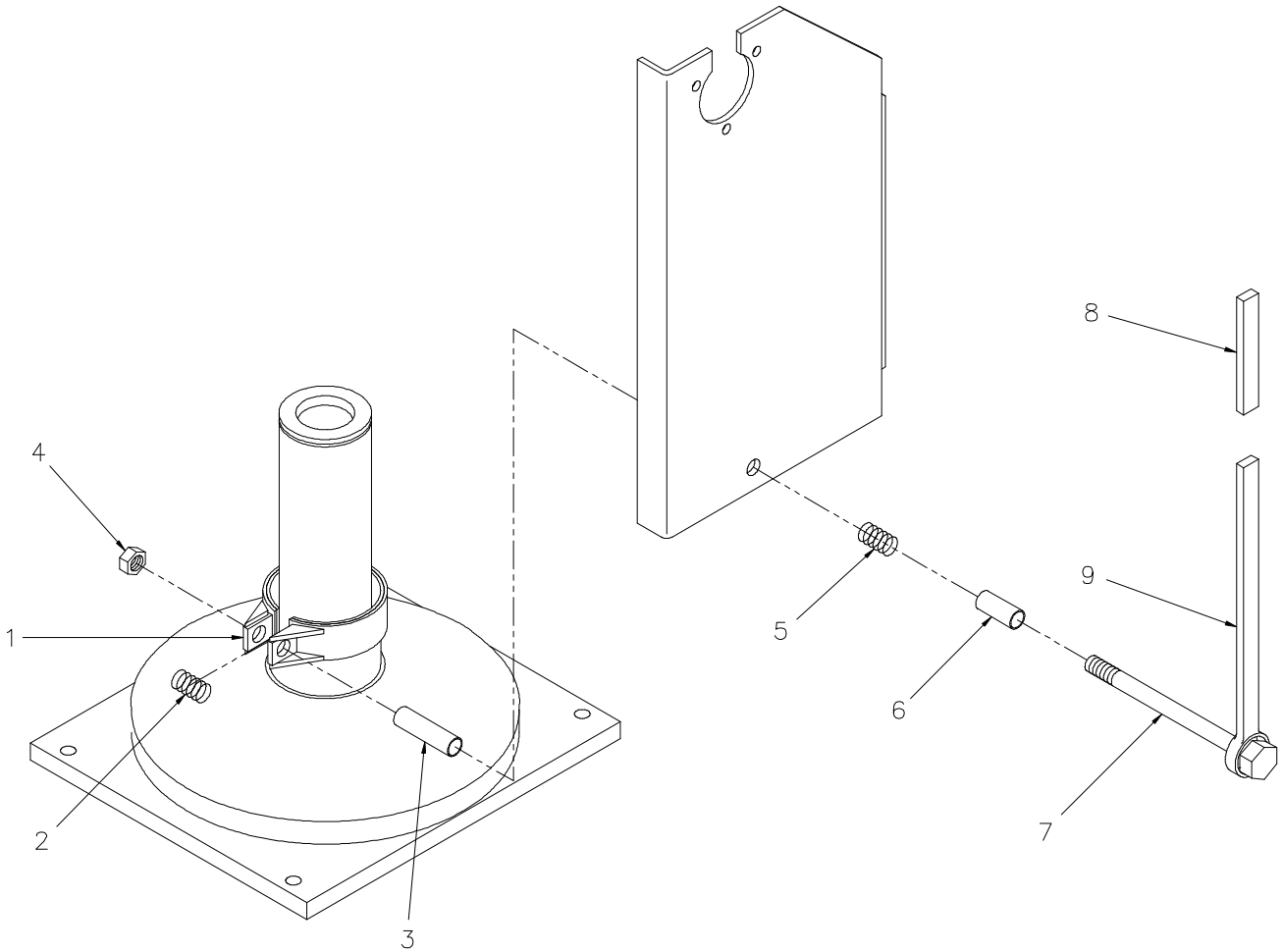

<u>ITEM</u>	<u>QTY</u>	<u>P/N</u>	<u>DESCRIPTION</u>
1	1	270376	BRAKE BAND ASSEMBLY
2	1	330184	COMPRESSION SPRING
3	1	330490	SPACER
4	1	018301	NUT HEX 5/8 NC
5	1	330488	COMPRESSION SPRING
6	1	330489	SPACER
7	1	013503	SCREW HEX HD 5/8 NC x 7 GR5
8	1	330303	HANDLE GRIP
9	1	330136	BRAKE HANDLE

TWECO ASSEMBLY

2703 SERIES

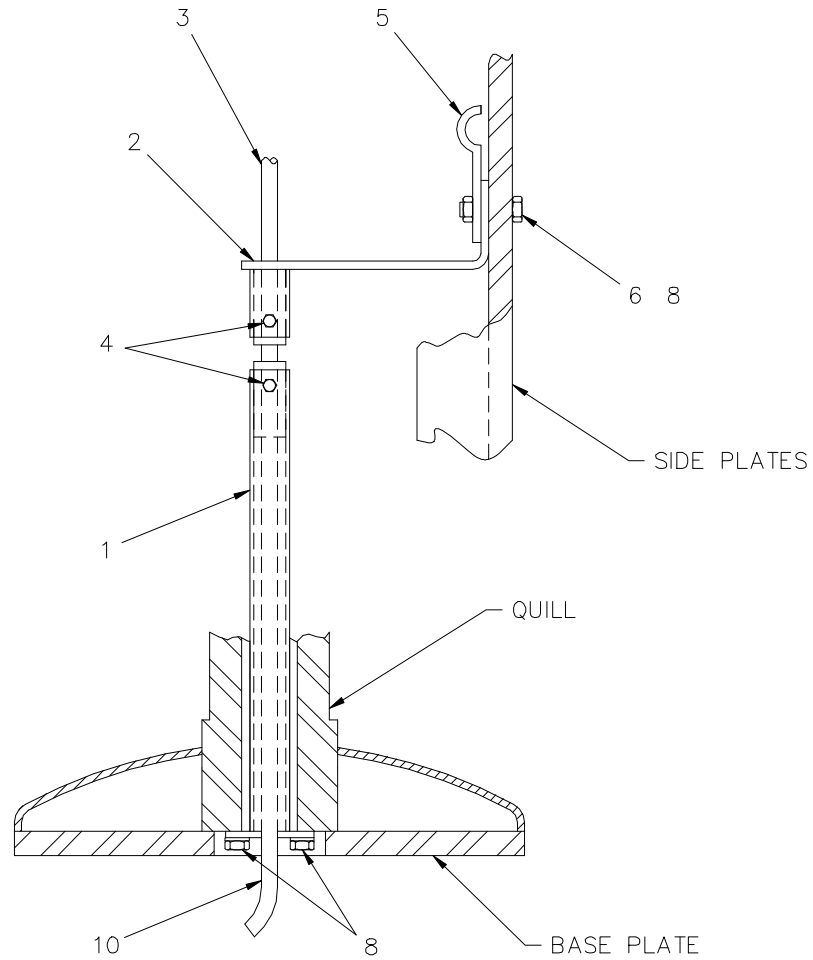

<u>ITEM</u>	<u>QTY</u>	<u>P/N</u>	<u>DESCRIPTION</u>
1	1	320488	POWER CABLE ASSEMBLY
2	1	330212	UPPER TWECO BRACKET
3	1	REF	MALE TWECO CONNECTOR
4	1	002900	SCREW HEX 1/4 x 3/8
5	1	000115	CLAMP
6	1	005500	SCREW HEX HD 1/4 NC x 3/4
7	1	015900	NUT HEX 1/4 NC
8	3	020200	WASHER SP LK 1/4
9	2	005401	SCREW HEX HD 1/4-20 x 5/8
10	1	REF	FEMALE TWECO CONNECTOR

TURNER ASSEMBLY (ELECTRIC)

2703 SERIES

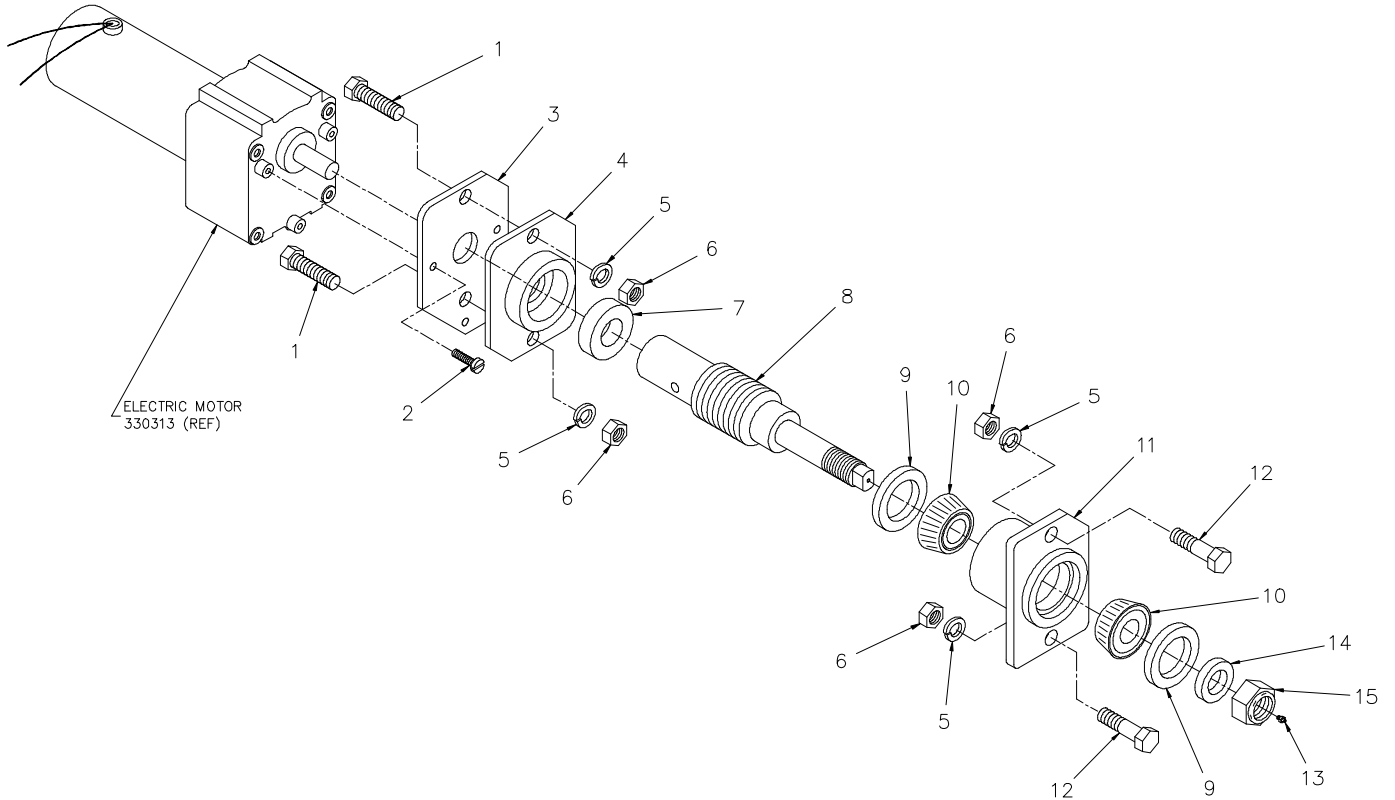

<u>ITEM</u>	<u>QTY</u>	<u>P/N</u>	<u>DESCRIPTION</u>
1	2	010201	SCREW HEX HD 1/2-13 NC x 1 1/2 GR5
2	3	330389	SCREW FLAT HD 1/4-20 NC x 1/2
3	1	330504	MOTOR MOUNT
4	1	330498	MOTOR MOUNT ASSEMBLY
5	4	021500	WASHER SP LK 1/2
6	4	017701	NUT HEX 1/2-13 NC
7	REF	330500	BEARING
8	1	330421	WORM
9	2	330486	OIL SEAL
10	2	330485	CONE BEARING
11	1	330472	BEARING HOUSING
12	2	011603	SCREW HEX HD 1/2-13 NC x 1 3/4 GR5
13	1	239300	GREASE ZERK
14	1	330483	SPACER
15	1	019000	NUT HEX 7/8-14 NF

TRAVELING BLOCK ASSEMBLY

P/N 320433

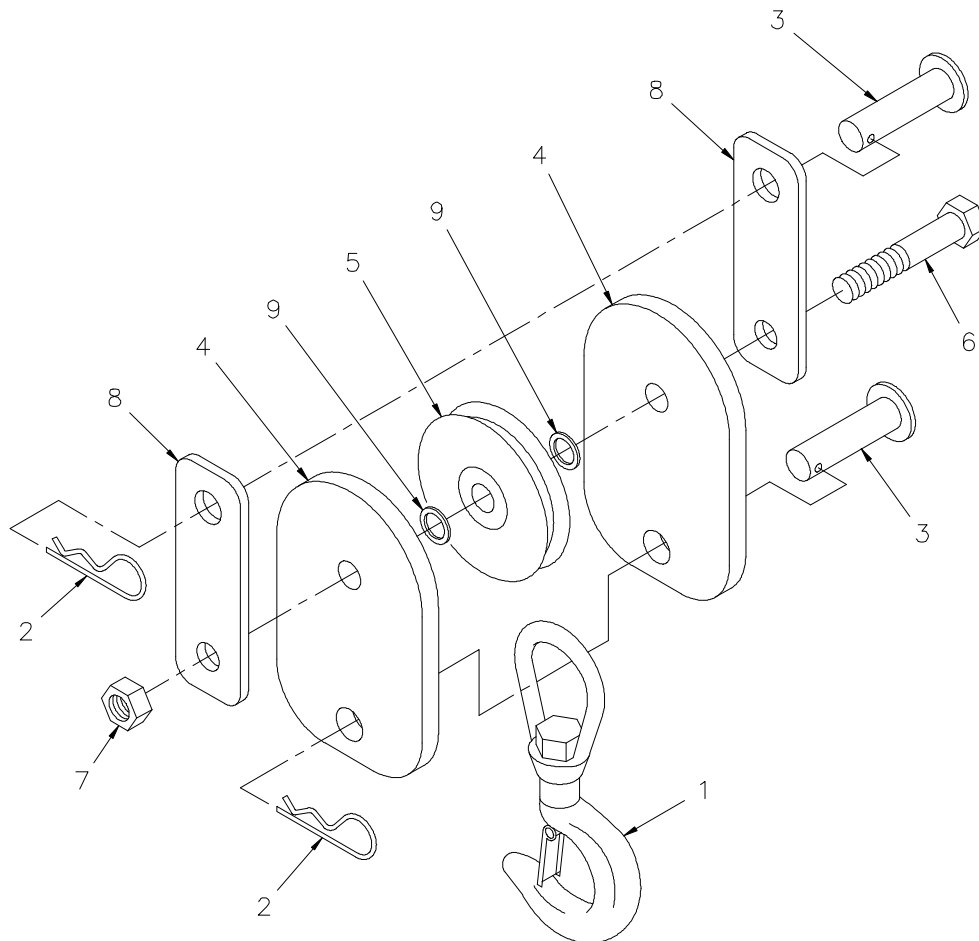

<u>ITEM</u>	<u>QTY</u>	<u>P/N</u>	<u>DESCRIPTION</u>
1	1	100309	SWIVEL HOOK
2	2	360124	HITCH PIN
3	2	320434	BLOCK PIN
4	2	320403	TRAVELING BLOCK
5	1	200909	SHEAVE ASSEMBLY w/ BEARING
6	1	013512	HEX HD SCREW 5/8 NC x 3 1/2
7	1	018200	HEX HALF LOCK NUT 5/8 NC
8	2	320404	BLOCK
9	2	330100	FLAT WASHER

NOTE: STANDARD 62' CABLE ASSEMBLY MAY BE ORDERED USING P/N 320338.
OPTIONAL 75' CABLE ASSEMBLY MAY BE ORDERED USING P/N 320339.

HOIST ACTUATOR ASSEMBLY

P/N 320324

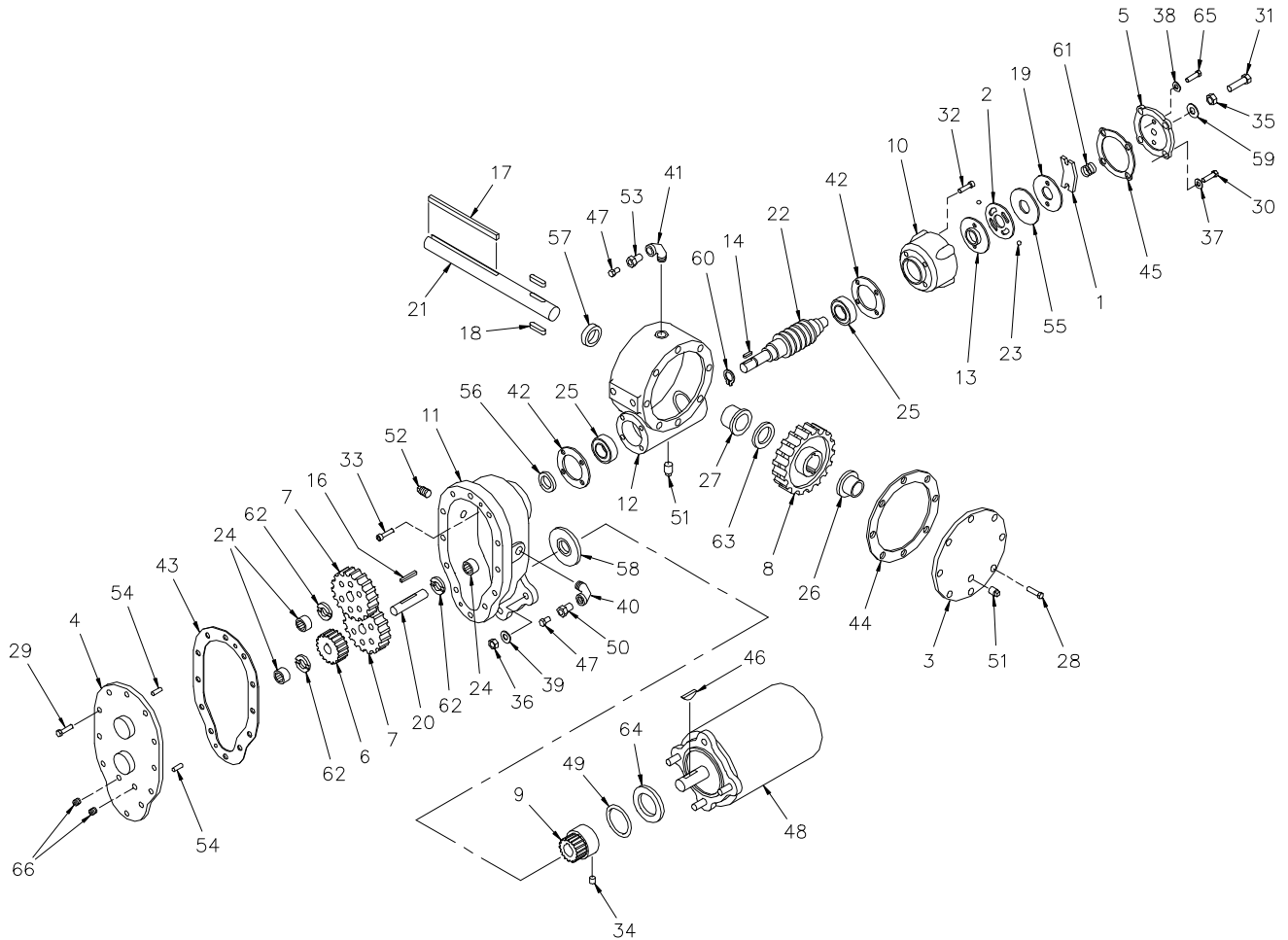

HOIST ACTUATOR ASSEMBLY

P/N 320324

<u>ITEM</u>	<u>QTY</u>	<u>P/N</u>	<u>DESCRIPTION</u>
1	1	360637	FLAT SPRING
2	1	360331	CAM PLATE
3	1	300041	GEAR HOUSING COVER
4	1	300042	SPUR GEAR HOUSING COVER
5	1	360450	BRAKE COVER
6	1	300043	IDLER GEAR
7	2	300044	SPUR GEAR
8	1	300045	WORM R.H. GEAR
9	1	300046	PINION GEAR
10	1	360336	BRAKE HOUSING
11	1	300047	SPUR GEAR HOUSING
12	1	300048	GEAR HOUSING
13	1	360339	BRAKE HUB
14	1	300049	KEY 3/16 SQ x 1/2 LG
15	-	-	-
16	1	300050	KEY 3/16 SQ x 1 9/16 LG
17	1	341561	KEY 1/4 SQ x 2 3/4 LG
18	2	300052	KEY RD 5/16 x 5/16 x 15/16 LG
19	1	360342	RETAINER PLATE
20	1	300053	SPUR GEAR SHAFT
21	1	320323	OUTPUT SHAFT
22	1	320312	RIGHT HAND WORM GEAR
23	2	360345	BALL
24	3	300056	NEEDLE BEARING
25	2	300057	BALL BEARING
26	1	300058	BUSHING
27	1	300059	BUSHING
28	10	320313	CAPSCREW 1/4-20 NC x 3/4 LG NYLOCK
29	12	005500	CAPSCREW 1/4-20 NC x 3/4 LG
30	4	005604	CAPSCREW 1/4-20 NC x 1 LG
31	1	320311	CAPSCREW 3/8 x 1 1/2 LG ALL THREAD
32	4	320310	CAPSCREW 1/4-20 NC x 1 LG
33	4	300060	SOCKET HEAD SCREW 1/4-20 NC x 3/4 LG LOC-WEL
34	1	300061	SETSCREW 1/4-20 NC x 5/16 LG LOC-WEL
35	1	360353	HEX JAM NUT 3/8-16 NC
36	3	071012	HEX NUT 3/8-24 NF
37	4	360354	SPLIT LOCK WASHER 1/4 MED SECT
38	2	360455	FLAT WASHER 1/4 ALUM

HOIST ACTUATOR ASSEMBLY

P/N 320324

<u>ITEM</u>	<u>QTY</u>	<u>P/N</u>	<u>DESCRIPTION</u>
39	3	021100	SPLIT LOCK WASHER 3/8
40	1	320314	90° ELBOW 3/8-18 NPT BOTH ENDS
41	1	320315	90° ELBOW 1/4-18 NPT BOTH ENDS
42	2	300062	GASKET BEARING
43	1	300063	SPUR GEAR HOUSING GASKET
44	1	300064	GEAR HOUSING COVER GASKET
45	1	360359	BRAKE COVER GASKET
46	1	300065	WOODRUFF KEY
47	2	300066	RELIEF FITTING
48	1	300067	12V MOTOR
49	1	300068	O-RING 1 OD x 1/8 THICK
50	1	300069	REDUCER -6 NPT / -2 NPT
51	2	300070	PLUG PIPE -4 NPT SQ HD
52	1	300073	PLUG PIPE -6 NPT HEX SOC HEADLESS
53	1	300074	REDUCER -4 NPT / -2 NPT
54	2	300075	DOWEL PIN
55	2	360364	THRUST PLATE
56	1	300076	OIL SEAL 3/4 ID x 1 1/4 OD x 1/4 THICK
57	1	300077	OIL SEAL 1 1/4 ID x 1 3/4 OD x 1/4 THICK
58	1	300078	OIL SEAL 1 1/2 ID x 2 1/4 OD x 5/16 THICK
59	1	360371	THREAD SEAL
60	1	300079	SNAP RING
61	1	360368	SPRING
62	3	300080	THRUST WASHER
63	1	300081	THRUST WASHER
64	1	300082	FIBER WASHER
65	2	360456	SCREW 1/4-20 NC x 1 LG ALL THREAD
66	2	320382	PIPE PLUG

AUTOMATIC SAFETY BRAKE ASSEMBLY (OIL COOLED) HOIST

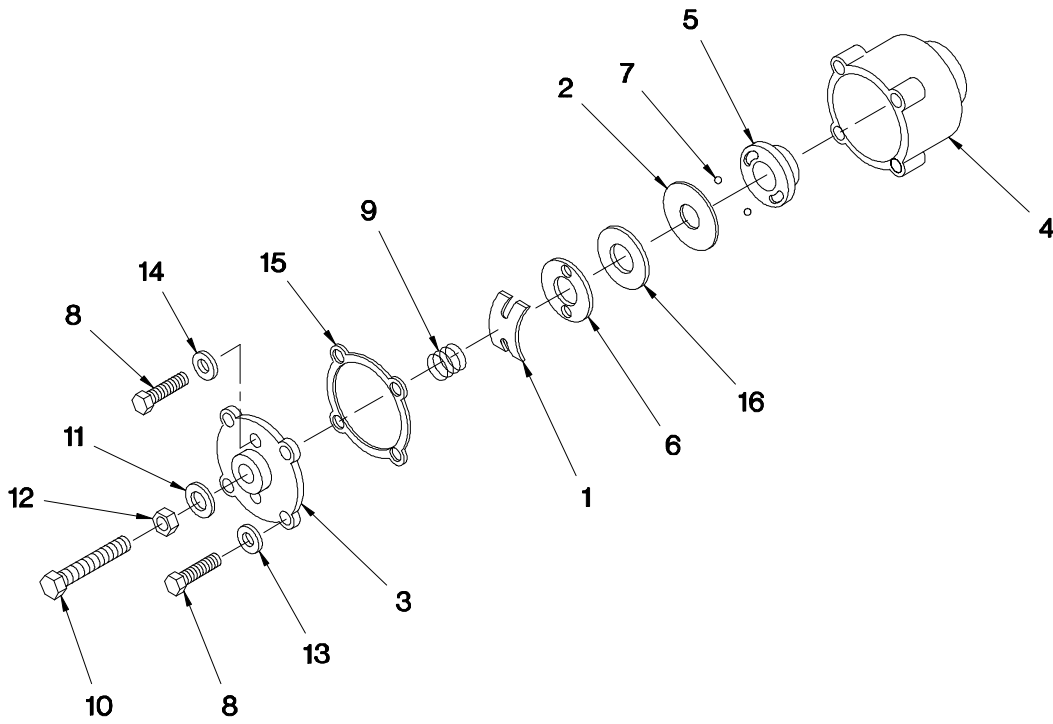

<u>ITEM</u>	<u>QTY</u>	<u>P/N</u>	<u>DESCRIPTION</u>
1	1	360367	FLAT SPRING
2	1	360331	CAM PLATE
3	1	360450	HOUSING COVER
4	1	360336	BRAKE HOUSING
5	1	360339	BRAKE HUB
6	1	360342	RETAINER PLATE
7	2	360345	BRAKE BALL
8	6	360453	CAPSCREW 1/4 NC x 1
9	1	360368	COIL SPRING
10	1	360456	CAPSCREW 3/8 NC x 1 1/2
11	1	360371	THREAD SEAL
12	1	360353	JAM NUT 3/8 NC
13	4	360465	THREAD SEAL
14	2	360455	WASHER FLAT 1/4 ALUM
15	1	360359	GASKET
16	1	360364	THRUST PLATE

AUTOMATIC SAFETY BRAKE ASSEMBLY

(OIL COOLED) HOIST

ASSEMBLY INSTRUCTIONS:

1. Winch has right hand worm and gear. Cable spools over drum. Use number one slots for brake balls(7) in cam plate(2).
2. Install brake hub(5) through brake housing(4) on winch worm with key.
3. Assemble balls(7) in cam plate(2) using hard grease to hold balls in place.
4. Place cam plate(2) on brake hub(5), matching its holes with the balls.
5. Install thrust plate(16).
6. Thread capscrew(10) with jam nut (12) and thread seal (11) through housing cover(3).
7. Place gasket(15) on housing cover(3).
8. Install coil spring(9) on capscrew(10).
9. Install flat spring(1) on capscrew(10).
10. Secure retainer plate(6) and flat spring(1) to housing cover(3) using capscrews(8) and washers(14).
11. Using capscrews(8) and thread seals(13) attach housing cover(3) to brake housing(4).
12. Test brake by shifting winch to UP then DOWN to see if brake is working in proper rotation. If not, remove housing cover(3) and locate brake balls(7) in opposite set of slots of cam plate(2).
13. Adjust to suit by tightening or loosening capscrew(10) on outside of housing cover(3). When proper adjustment is obtained, secure capscrew(10) with jam nut(12).

SAFETY DECAL SECTION

PART NO.: 040517
DECAL: STAY CLEAR OF BOOM
FUNCTION: To inform the operator of the hazard of proximity or contact with the crane boom during operation.
QUANTITY: 2
PLACEMENT: Both sides of crown
(see page 4-2.0.0, Item 1)



FIG. SD-1.

PART NO.: 040518
DECAL: STAY CLEAR OF LOAD
FUNCTION: To inform the operator of the hazard of proximity or contact with the crane load during operation.
QUANTITY: 2
PLACEMENT: Both sides of down haul weight
(see page 4-2.0.0, Item 12)



FIG. SD-2.

PART NO.: 040519
DECAL: SCISSORS POINT
FUNCTION: To inform the operator of possible danger at scissors point on crane.

QUANTITY: 1
PLACEMENT: Both sides of lift cylinder
(see page 4-2.0.0, Item 15)



FIG. SD-3.

SAFETY DECAL SECTION

PART NO.: 040529 QUANTITY: 2
DECAL: ELECTROCUTION HAZARD PLACEMENT: Both sides of lower boom
FUNCTION: To inform the operator of the hazard involved with contacting electrical power lines with crane boom. (see page 4-2.0.0, Item 2)

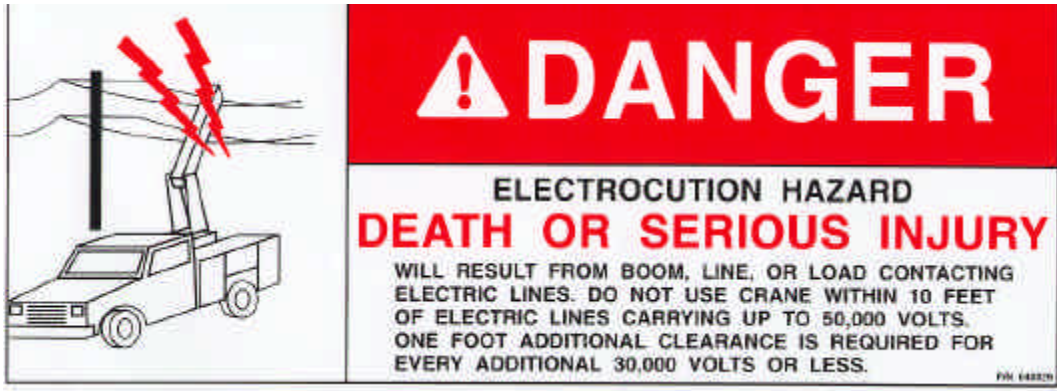

FIG. SD-4.

PART NO.: 040579
DECAL: OPERATION INSTRUCTIONS
FUNCTION: To inform the operator of the proper procedure to follow for safe operation of the crane.
QUANTITY: 1
PLACEMENT: Sideplate
(see page 4-2.0.0, Item 5)

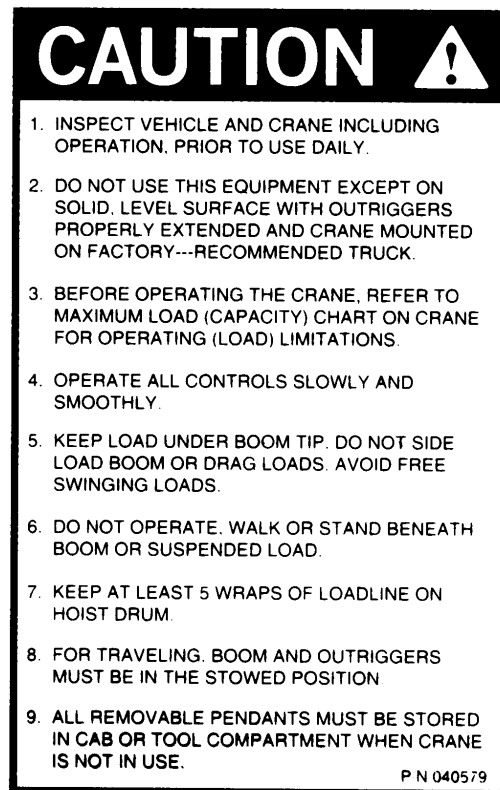

FIG. SD-5.

SAFETY DECAL SECTION

PART NO.: 040580
DECAL: OPERATOR TRAINING
FUNCTION: To inform the operator of the need to receive proper training before using the crane.
QUANTITY: 1
PLACEMENT: Sideplate
(see page 4-2.0.0, Item 6)

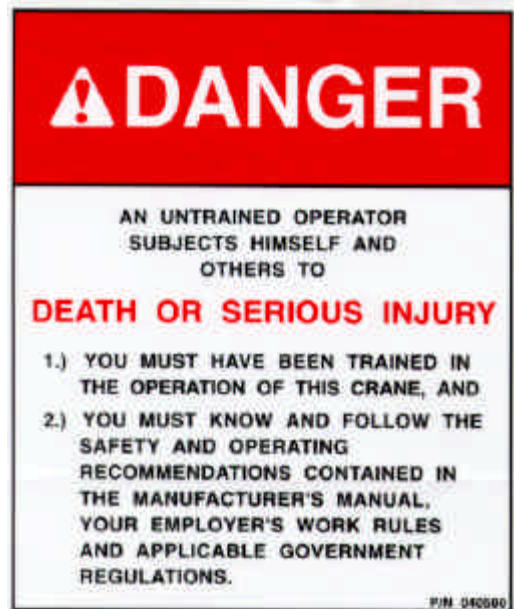
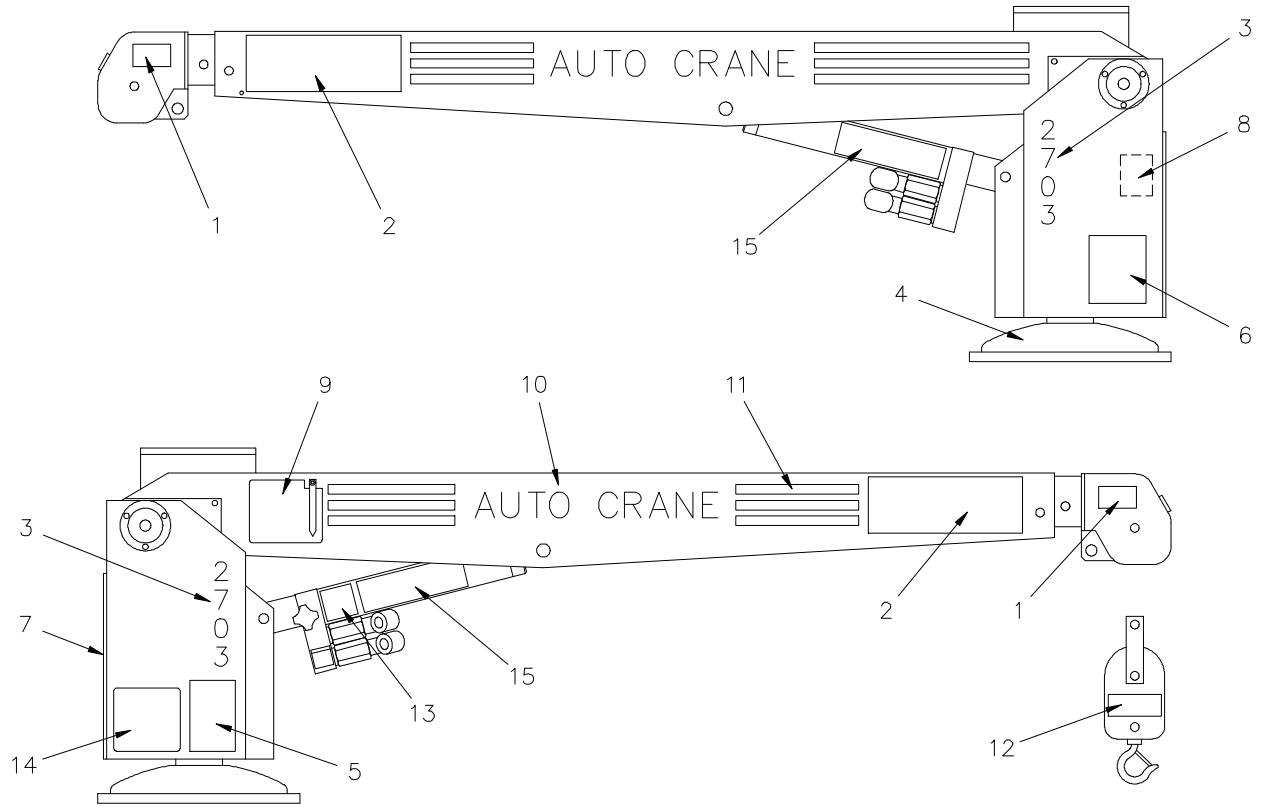

FIG. SD-7.

DECAL DRAWING

2703 SERIES



<u>ITEM</u>	<u>QTY</u>	<u>P/N</u>	<u>DESCRIPTION</u>
1	2	040517	STAY CLEAR DECAL
2	2	040529	DANGER ELECTROCUTION DECAL
3	2	270321	2703 DECAL
4	1	330622	SERIAL NO DECAL
5	1	040579	WORK RULES DECAL
6	1	040580	DANGER DECAL
7	1	040622	A/C LOGO DECAL
8	1	040552	RELAY
9	1	360036	ANGLE INDICATOR DECAL
10	2	040624	AUTO CRANE DECAL
11	10'	040620	STRIPING DECAL
12	2	040518	STAY CLEAR DECAL
13	1	330624	LOWER BOOM DECAL
14	1	270322	LOAD CHART DECAL
15	2	040519	SCISSORS POINT DECAL

GENERAL DIMENSIONS

2703 M 6-10-14

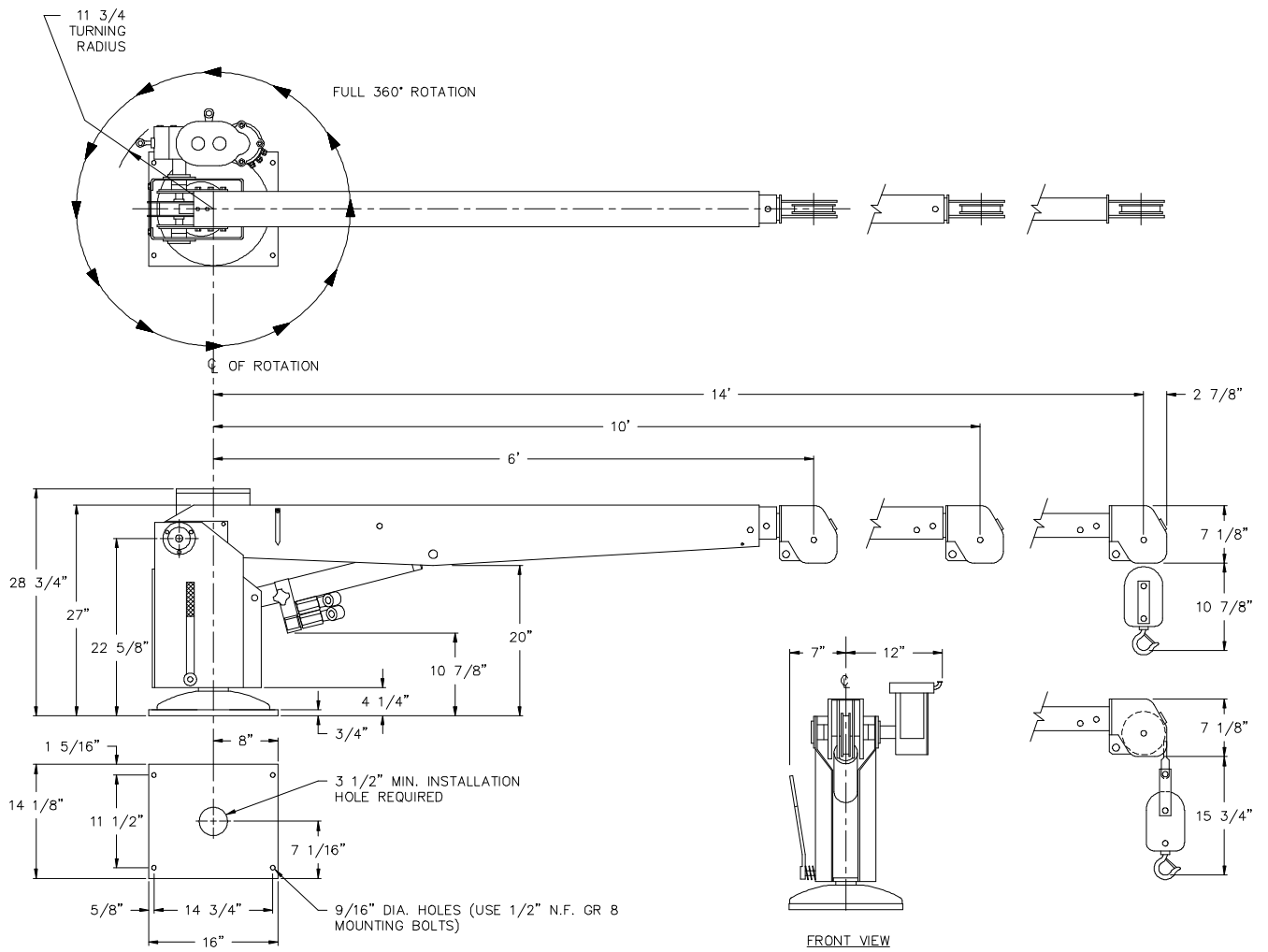

GENERAL DIMENSIONS

2703 M 6-10

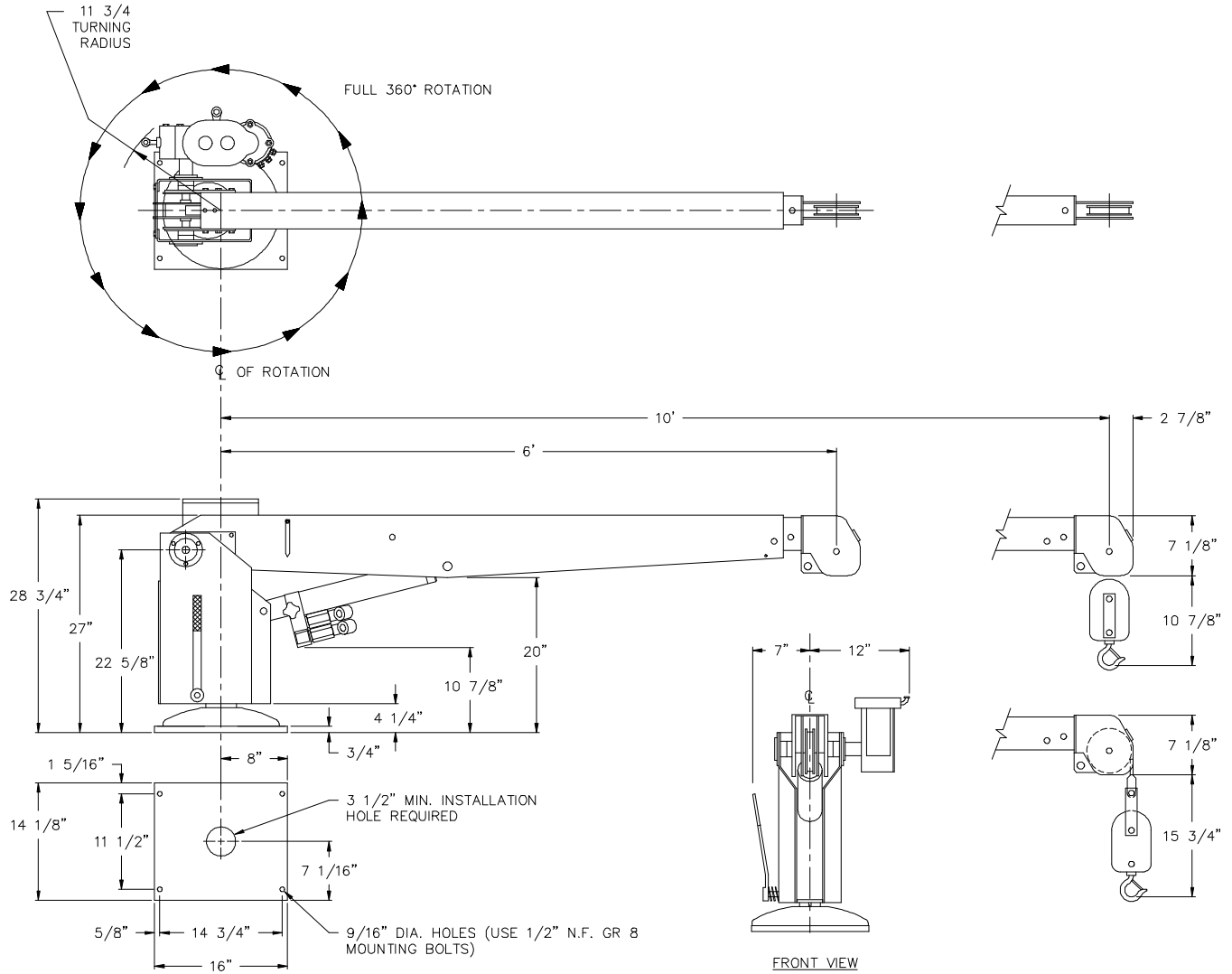

GENERAL DIMENSIONS

2703 MR 6-10-14

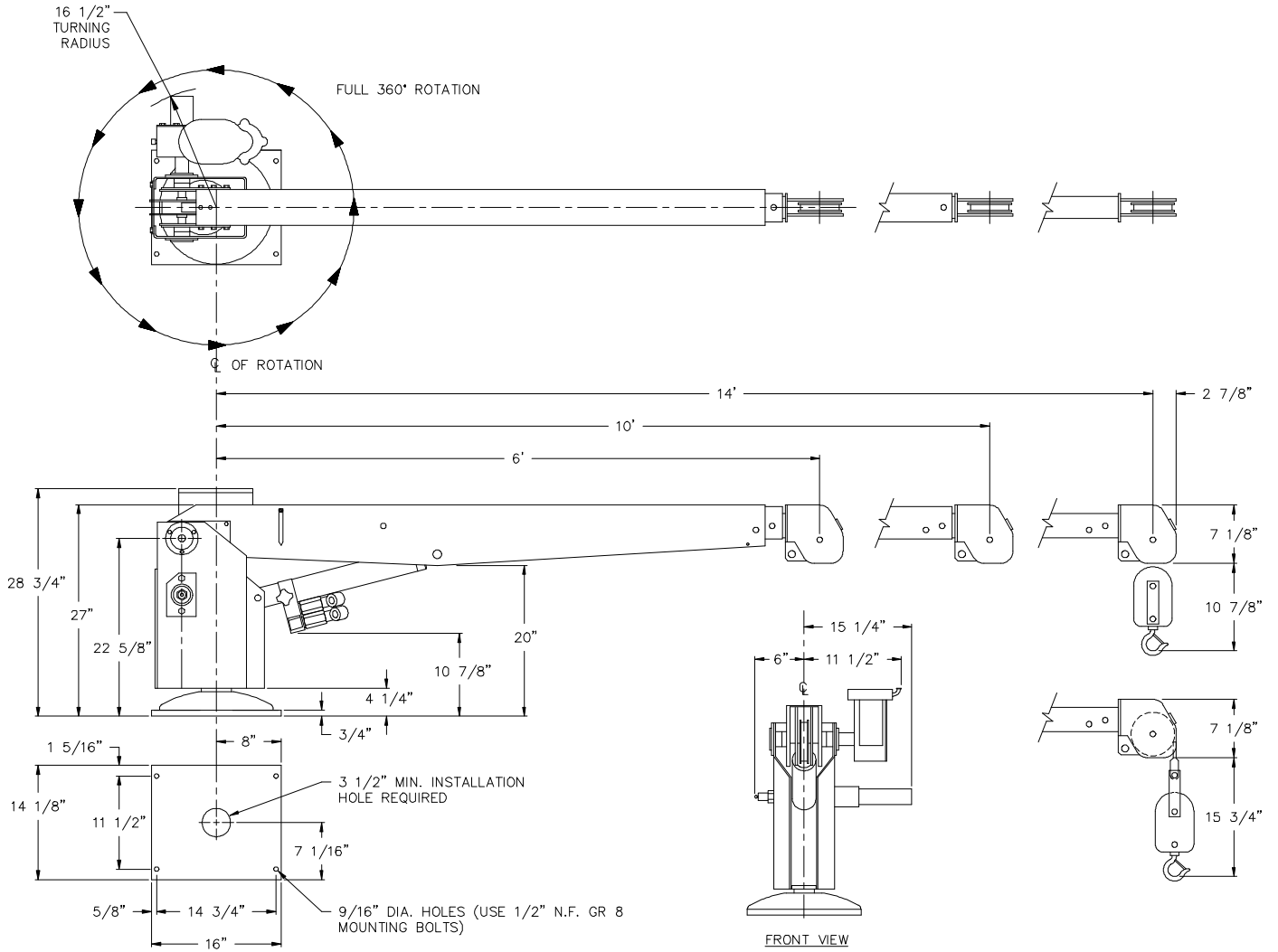

GENERAL DIMENSIONS

2703 MR 6-10

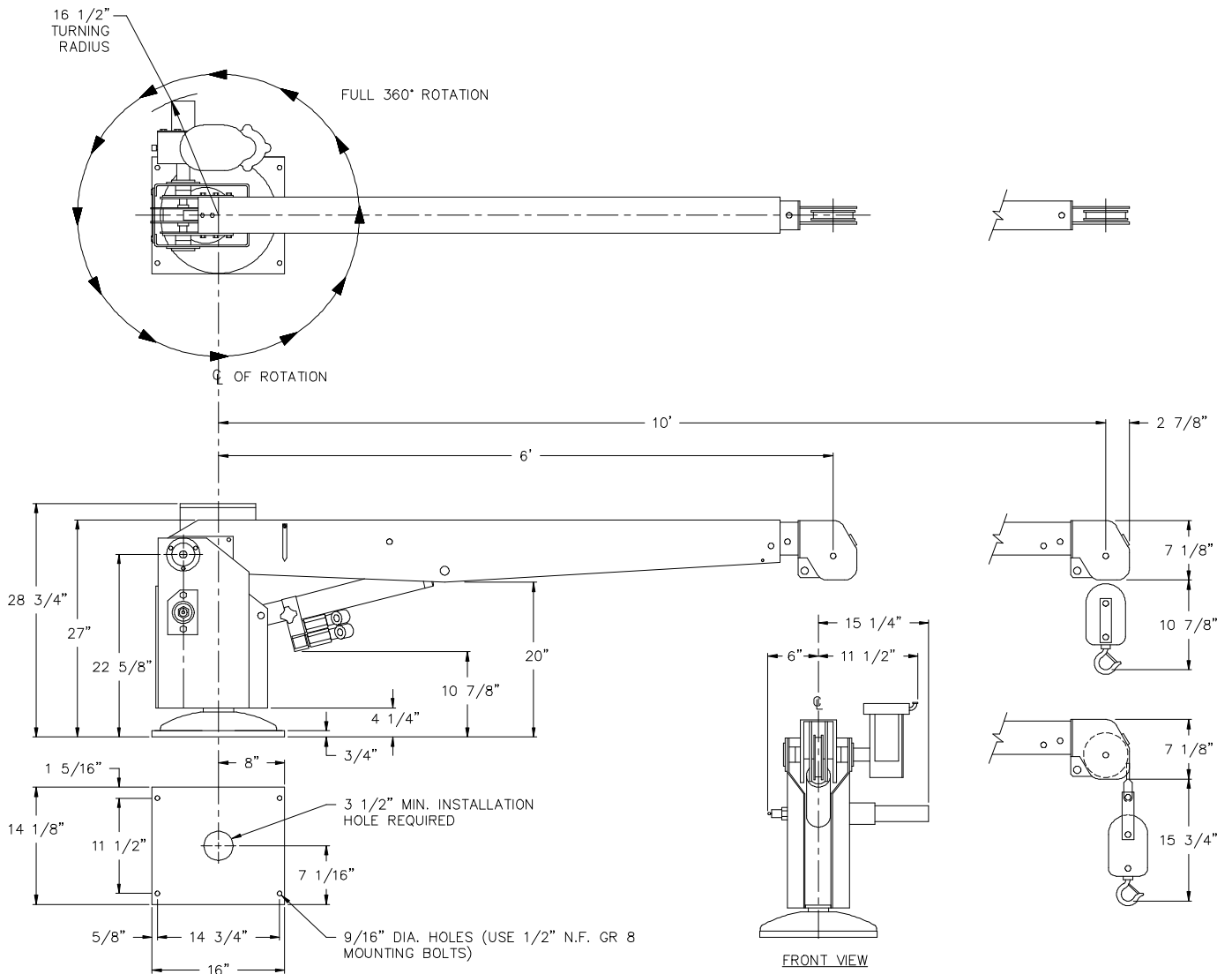

GENERAL DIMENSIONS

2703 PR 6-10-14

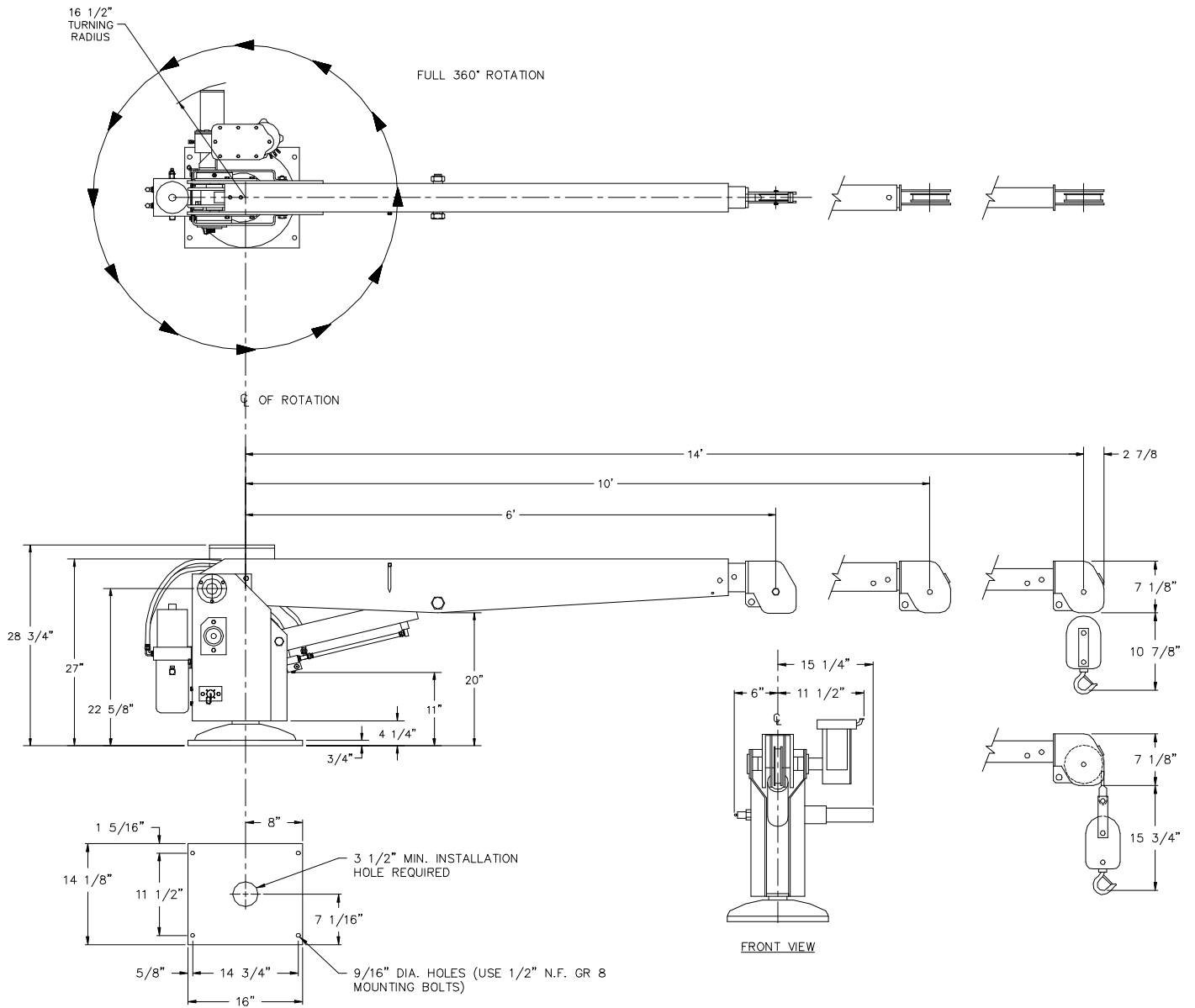

GENERAL DIMENSIONS

2703 PR 6-10

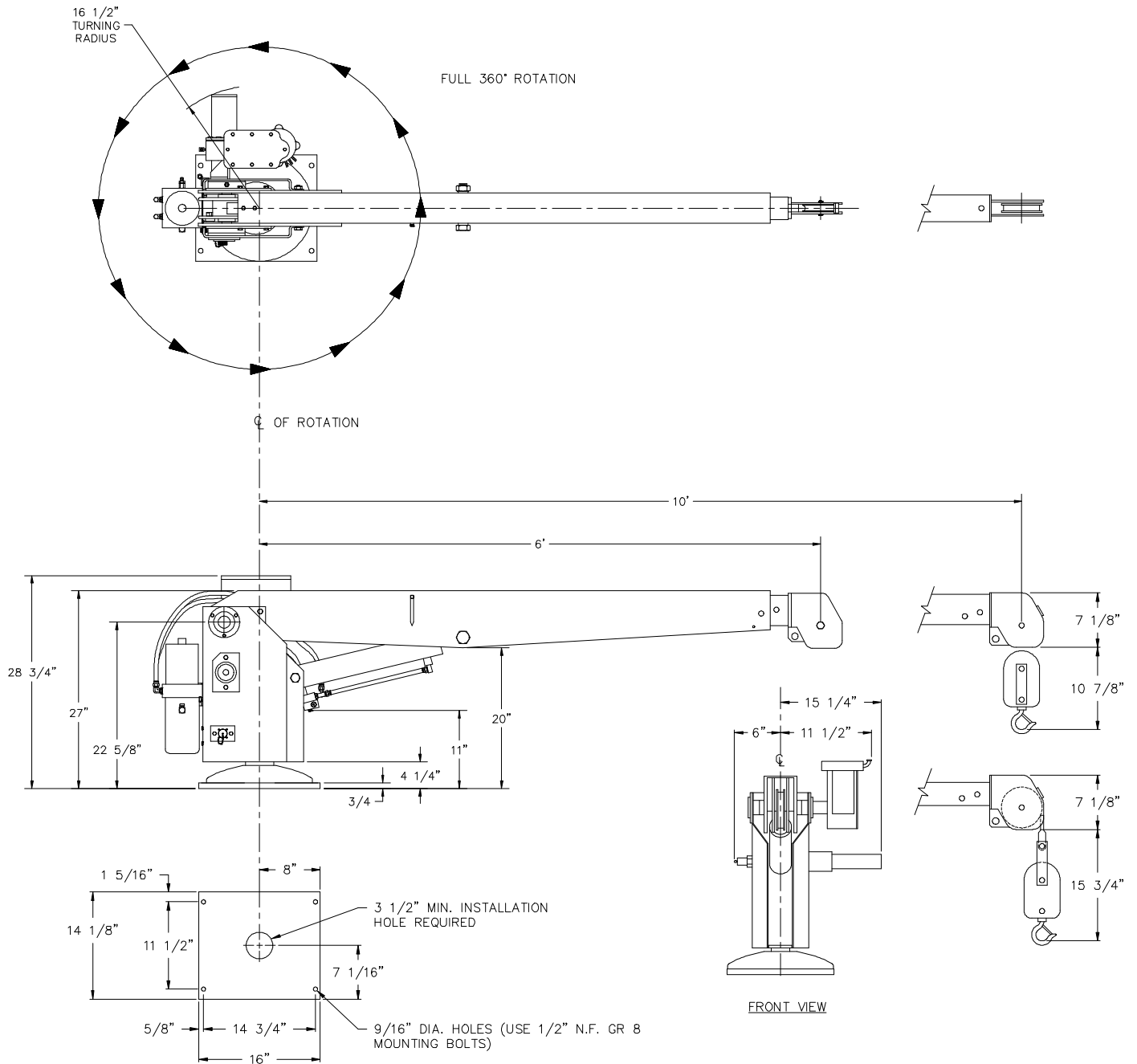

PENDANT ASSEMBLY BAYONET w/ 18' LG CABLE

P/N 270410 - 2703 PR

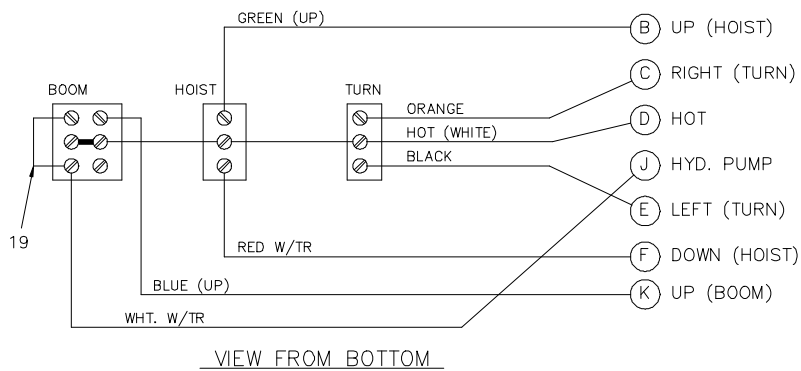
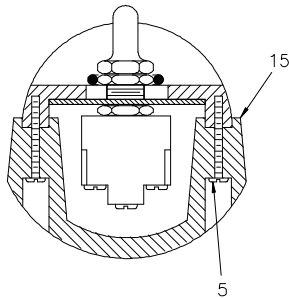
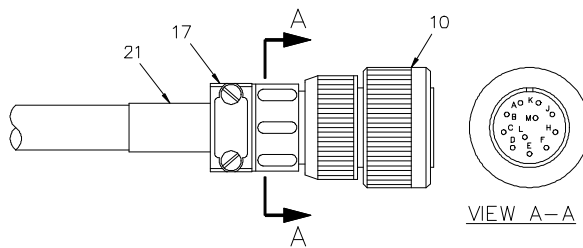
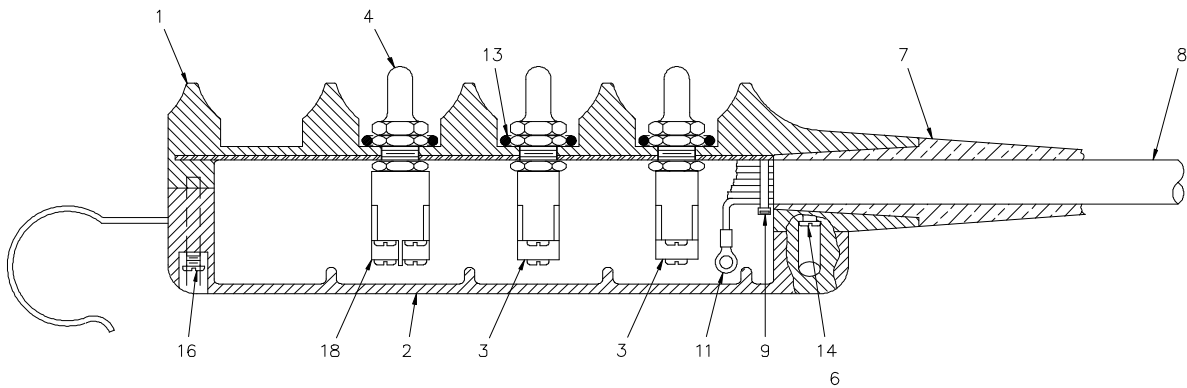

PENDANT ASSEMBLY BAYONET w/ 18' LG CABLE

P/N 270410 - 2703 PR

<u>ITEM</u>	<u>QTY</u>	<u>P/N</u>	<u>DESCRIPTION</u>
1	1	631602	PENDANT HOUSING
2	1	631700	BOTTOM COVER
3	2	622000	TOGGLE SWITCH
4	3	640300	BOOT-TOGGLE SWITCH
5	10	001004	SCREW ST SLT PAN HD #6 x 3/4
6	2	005101	SCREW ST SLT PAN HD #8 x 1 1/4
7	1	633801	CABLE ADAPTER
8	18'	800630	CONDUCTOR CABLE
9	2	634401	TY-RAP CABLE TIE
10	1	320563	11 PIN BAYONET PLUG
11	15	000101	TERMINALS T & B
12	-	-	-
13	3	642100	O-RING
14	4	019700	WASHER SP LK #8 PLATED
15	1.75	800580	3/4 WIDE OKONITE RUBBER TAPE
16	1	004700	SCREW ST SLT PAN HD #8 x 1 1/2
17	1	480515	CABLE CLAMP
18	1	634200	TOGGLE SWITCH
19	2	636600	JUMPER BAR
20	0.25	800592	WHITE WIRE 16GA x 3
21	6"	480243	HEAT SHRINK TUBING

PENDANT ASSEMBLY

P/N 680068 - 2703 MR

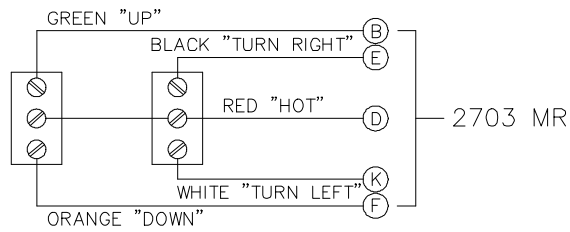
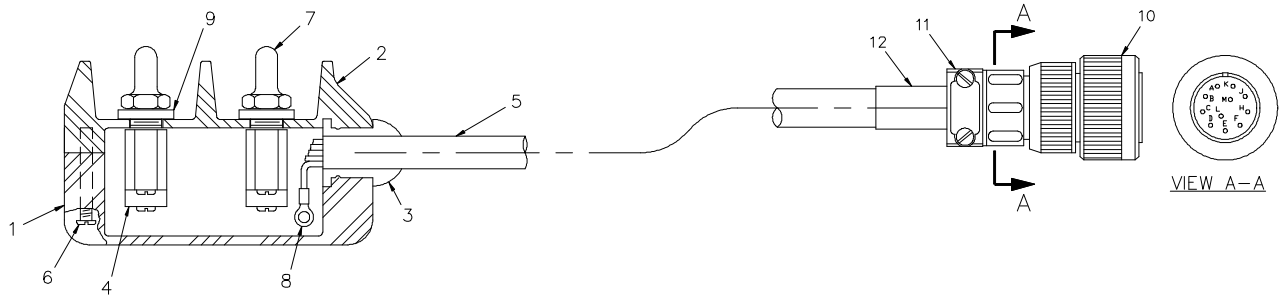

ITEM	QTY	P/N	DESCRIPTION
1	1	370130	PENDANT BOX
2	1	370131	PENDANT COVER
3	1	370132	PENDANT HOUSING GASKET
4	2	622000	TOGGLE SWITCH
5	17'	800629	CONDUCTOR CABLE
6	4	001207	RECESSED CROSS PAN HD SCREW #8 x1"
7	2	640302	BOOT
8	7	000101	TERMINAL RING
9	2	370135	PINION GEAR
10	1	320563	11 PIN BAYONET PLUG
11	1	480515	CABLE CLAMP
12	6"	490243	HEAT SHRINK TUBING

HOIST CONTROL PENDANT

P/N 330519 - 2703 M

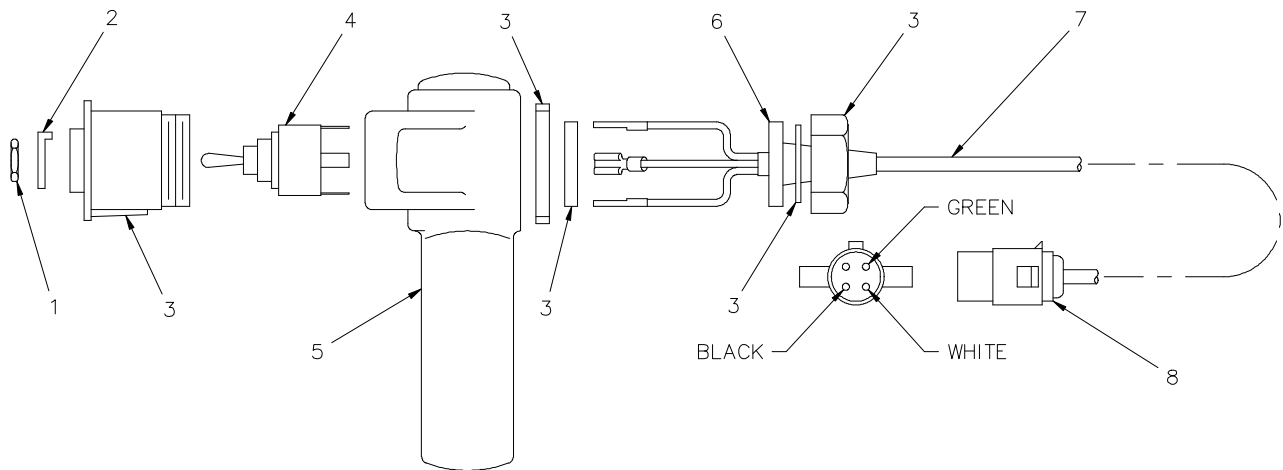

<u>ITEM</u>	<u>QTY</u>	<u>P/N</u>	<u>DESCRIPTION</u>
1	1	675271	HEX NUT
2	1	675281	WASHER TANG
3	1	675206	HOUSING KIT
4	1	675202	SWITCH w/ SEAL NUT
5	1	675201	HOUSING
6	1	675261	SEAL
7	1	675291	CABLE PENDANT
8	1	330518	FEMALE PLUG

HYDRAULIC ASSEMBLY

2703 PR

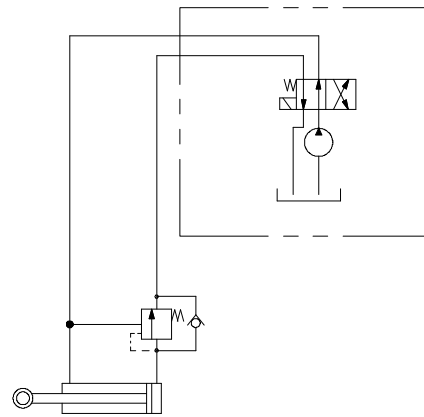
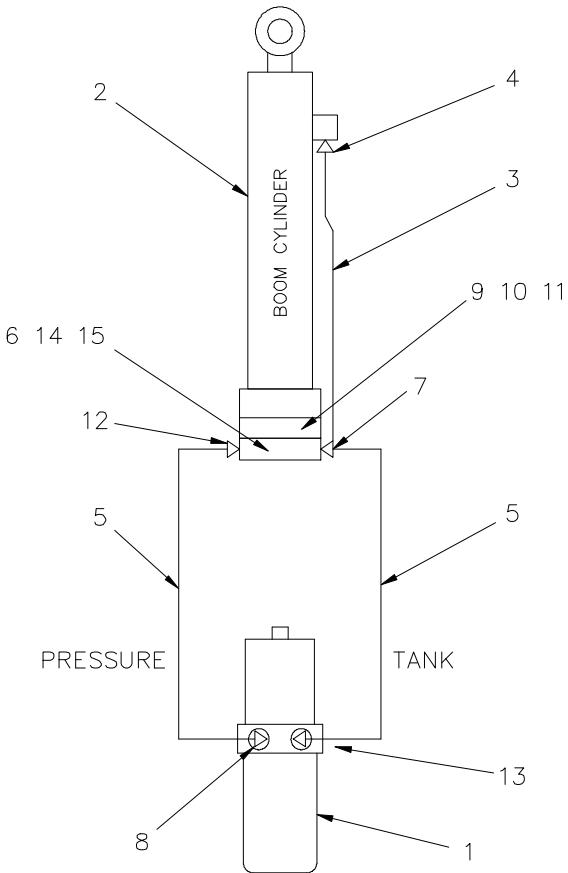

SCHEMATIC

<u>ITEM</u>	<u>QTY</u>	<u>P/N</u>	<u>DESCRIPTION</u>
1	1	270324	HYDRAULIC PUMP
2	1	330250	HYDRAULIC CYLINDER
3	1	812203-014	HOSE ASSEMBLY x 14
4	1	200892	ELBOW 90° 3/8 NPT / -6 JIC
5	2	812206-041	HOSE ASSEMBLY x 41
6	1	330412	HOLDING VALVE
7	1	200877	TEE STRAIGHT THREAD RUN
8	1	241175	ELBOW 90° -6 ORB / -6 JIC
9	1	368985	MANIFOLD SENSE VALVE
10	1	241169	O-RING
11	1	320543	PRESSURE SWITCH (REF)
12	1	200876	ADAPTER ST-6JIC
13	1	330645	ELBOW JIC6/ORB6 LONG
14	2	006700	HEX HD SCREW 1/4 x 2 1/2
15	2	020200	LOCK WASHER 1/4

RELAY ASSEMBLY BAYONET

P/N 680052 - 2703 MR

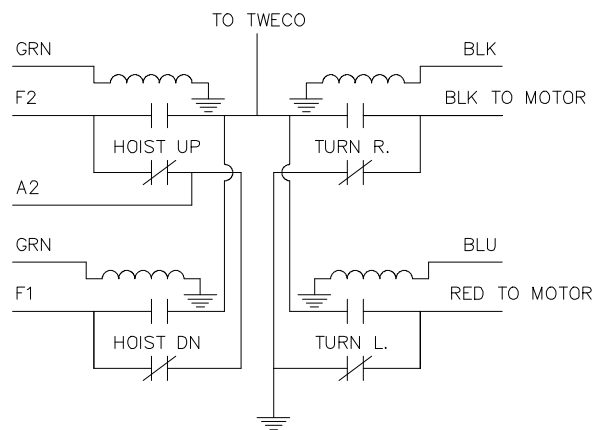
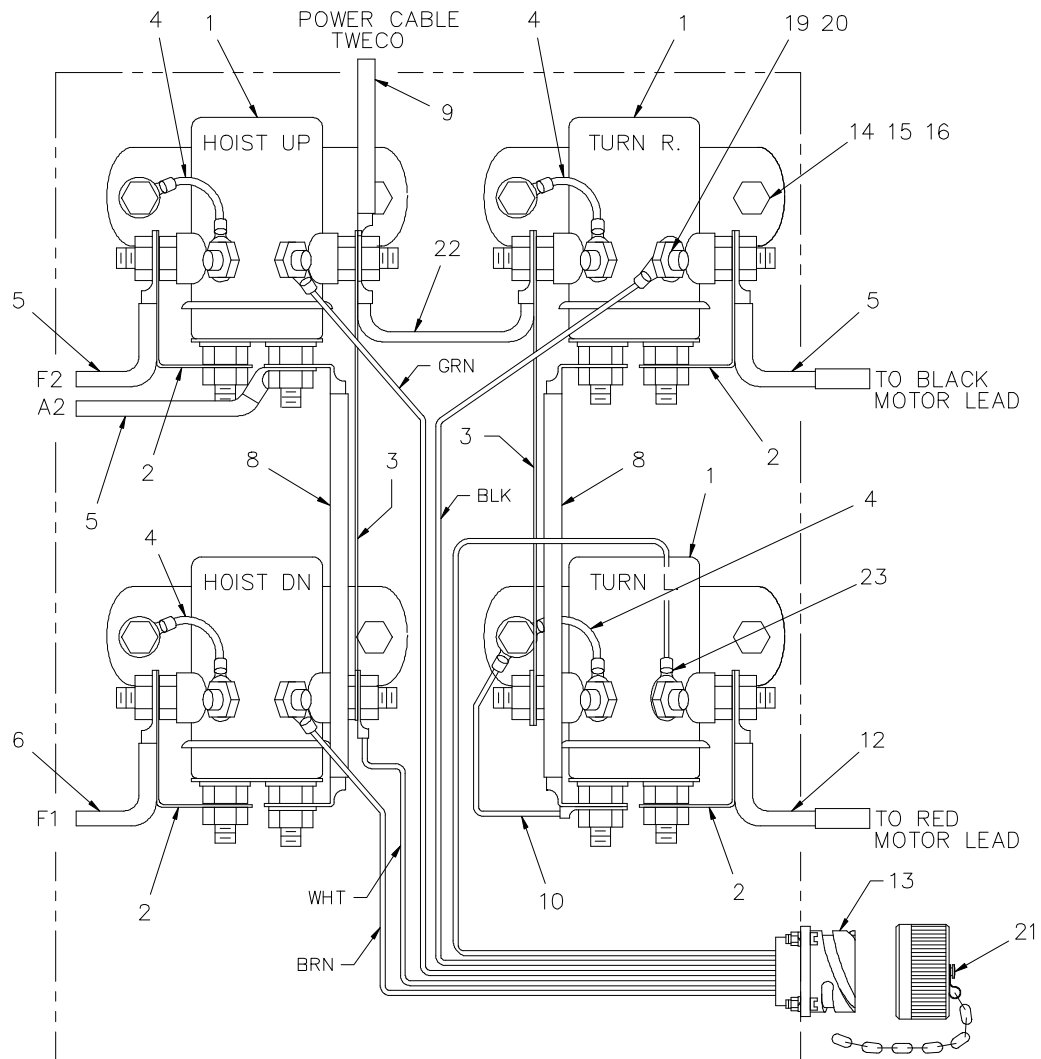

SCHMATIC

RELAY ASSEMBLY BAYONET

P/N 680052 - 2703 MR

<u>ITEM</u>	<u>QTY</u>	<u>P/N</u>	<u>DESCRIPTION</u>
1	4	200182	RELAY
2	4	658300	CONDUCTOR
3	2	658400	CONDUCTOR
4	4	659904	CONDUCTOR
5	2	622323	CONDUCTOR
6	1	622327	CONDUCTOR
7	1	000300	TERMINAL WIRE RB-14-10
8	2	600304	CONDUCTOR
9	1	REF	TWECO ASSEMBLY
10	1	330386	CONDUCTOR
11	1	330388	CONDUCTOR
12	1	330387	CONDUCTOR
13	1	680053	CONDUCTOR
14	8	020200	CONDUCTOR
15	8	015900	CONDUCTOR
16	8	005604	CONDUCTOR
17	16	016800	CONDUCTOR
18	16	020700	TERMINAL WIRE RB-14-10
19	8	015600	CONDUCTOR
20	8	020001	TWECO ASSEMBLY
21	1	320564	CONDUCTOR
22	1	330415	CONDUCTOR

RELAY ASSEMBLY BAYONET

P/N 270416 - 2703 PR

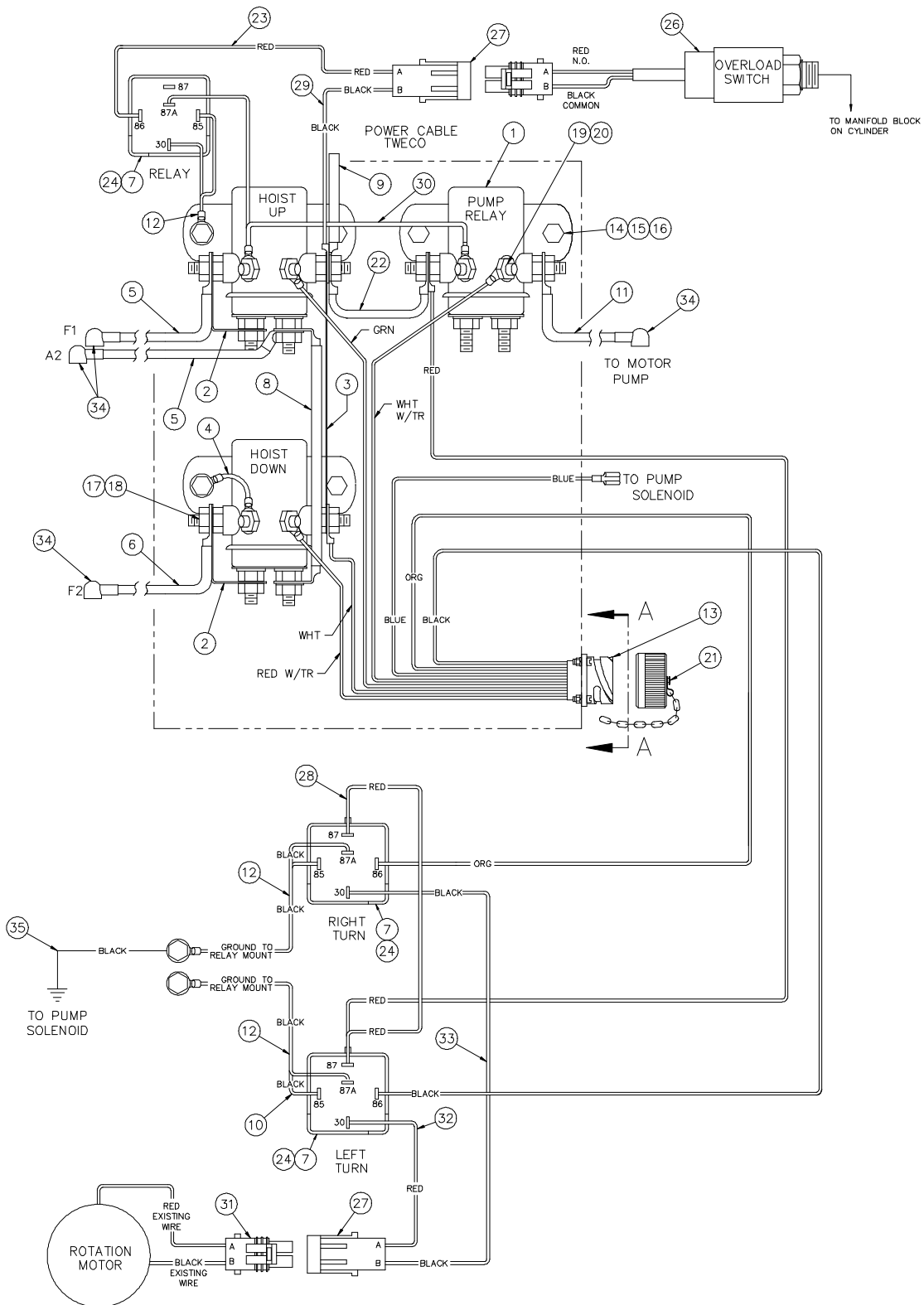

RELAY ASSEMBLY BAYONET

P/N 270416 - 2703 PR

ITEM	QTY	P/N	DESCRIPTION
1	3	200182	RELAY
2	2	658300	RELAY CONDUCTOR
3	1	658400	RELAY CONDUCTOR
4	1	659904	WHITE CONDUCTOR 16GA x 4
5	1	622323	BLACK CONDUCTOR 6GA WELD x 26
6	1	622327	BLACK CONDUCTOR 6GA WELD x 28
7	3	320355	DROP OUT BOSCH RELAY
8	1	600304	BLACK CONDUCTOR 6GA WELD x 4
9	1	330258	TWECO ASSEMBLY (REF)
10	1	270421	WIRE HARNESS x 3
11	1	270434	BLACK CONDUCTOR 4GA WELD x 14
12	3	270422	WIRE HARNESS 7 & 7
13	1	270417	PENDANT CONDUCTOR ASSEMBLY
14	8	020200	LOCK WASHER 1/4
15	8	015900	NUT 1/4-20
16	8	005604	SCREW HEX HD 1/4-20 x 1
17	14	016800	NUT HEX HALF 5/16 NF
18	14	020700	LOCK WASHER INTERNAL 5/16
19	6	015600	NUT #10-32
20	6	020001	LOCK WASHER INTERNAL #10
21	1	320564	BAYONET RECEPTACLE CAP (REF)
22	1	270423	WIRE HARNESS x 24
23	1	270424	WIRE HARNESS x 15
24	3	320363	TERMINAL CONNECTOR PLUG
25	3	750737	CABLE TIE
26	1	320543	LOAD SENSOR SWITCH
27	2	366250	CONNECTION WEATHERPACK 2-WAY MALE 18-20
28	1	270411	WIRE HARNESS 4 & 15
29	1	270425	WIRE HARNESS x 15
30	1	270426	WIRE HARNESS 7 & 20
31	1	366251	CONNECTION WEATHER PACK 2-WAY FEMALE 18-20
32	1	270427	WIRE HARNESS x 4
33	1	270428	WIRE HARNESS x 4
34	4	270326	INSULATOR BOOT BLACK
35	1	270435	WIRE HARNESS x 11

TROUBLESHOOTING 2703

<u>PROBLEM</u>	<u>CAUSE/SOLUTION</u>
CRANE WILL NOT HOIST UP OR DOWN.	<p><u>CAUSE:</u> Bad relay, crane not grounded properly, or power cable not connected to 12V power source. Bad switch in pendant, broken wire in pendant connector, pendant not plugged together properly, wire on relay not in proper place or lead wires to motor not connected properly.</p> <p><u>SOLUTION:</u> Problems can be solved by replacing bad relay, grounding the crane properly to the truck chassis, connecting the power cable properly to 12V+ power source, switch in pendant can be replaced, cord in remote control can be replaced, check connector on cord to make sure of contact of all the prongs on it are plugged together correctly, make sure wires on relays are according to the wiring print supplied with each new crane in the owner book and also wires going to motor are connected properly. NOTE: 12V must pass through opposite relay to complete circuit.</p>
WITH LOAD SENSOR (OPT.) CRANE WILL NOT HOIST UP OR BOOM UP AND DOWN.	<p><u>CAUSE:</u> Crane is overloaded. Sensor switch is bad. Bad connection to relays.</p> <p><u>SOLUTION:</u> Hoist down. Do not overload crane. Replace sensor switch. Check for loose or damaged wiring.</p>
CRANE RUNS UP OR DOWN ANY TIME POWER SOURCE IS CONNECTED.	<p><u>CAUSE:</u> Relay stuck in run position which will let crane run up or down any time 12V power is connected. Wires shorted together in remote control. Lead or cable can also cause this problem. Wires jumped across relay in wrong place can cause crane to run all the time.</p> <p><u>SOLUTION:</u> Problem can be solved by checking the relays and replacing the bad one or removing jumper wires from the relays or replacing the remote control cord or switch.</p>

TROUBLESHOOTING 2703

PROBLEM

CAUSE/SOLUTION

CRANE WILL NOT BOOM UP OR DOWN.

CAUSE:

Bad pump, crane not grounded properly, or power cable not connected to 12V power source. Bad switch in pendant, broken wire in pendant connector, pendant not plugged together properly, wire on relay not in proper place or lead wires to motor not connected properly.

SOLUTION:

Problems can be solved by replacing bad pump, grounding the crane properly to the truck chassis, connecting the power cable properly to 12V+ power source, switch in pendant can be replaced, cord in remote control can be replaced, check connector on cord to make sure of contact of all the prongs on it are plugged together correctly, make sure wires on relays are according to the wiring print supplied with each new crane in the owner book and also wires going to motor are connected properly.

TROUBLESHOOTING 2703

HOW TO CHECK RELAY:

Our relays are normally closed across the bottom posts (C & D). When activated, they will open across (C & D) and close across A & B). To activate these relays, use 12V positive and 12V negative wires and place them on posts (F & E). You may place 12V+ on post F or E as long as you place 12V on the remaining post (F & E) using an ohm meter or test light. Check across posts (A & B). You should get an ohm reading or your test light should be on when you have the relay activated. With the relay still activated, check across posts (C & D). You should have no ohm reading or test light at this point with relay activated. (At this point, disconnect 12V+ and 12V- from posts (F & E). This

should let relay return to its normal position. Using your ohm meter or test light again, check the relay across posts (A & B). If relay is working correctly, you should have no reading at all. Then check across posts (C & D). You should have an ohm reading or test light should be on. If you get the above results, relay is okay. If you get any variation in the above explanation on the relay you are checking, check the relay again. If it still shows a difference, the relay is bad and should be replaced. **NOTE: The above explanation is with relays completely disconnected from all wires on motor circuits and ground wires. These circuits can give you false readings sometimes.**

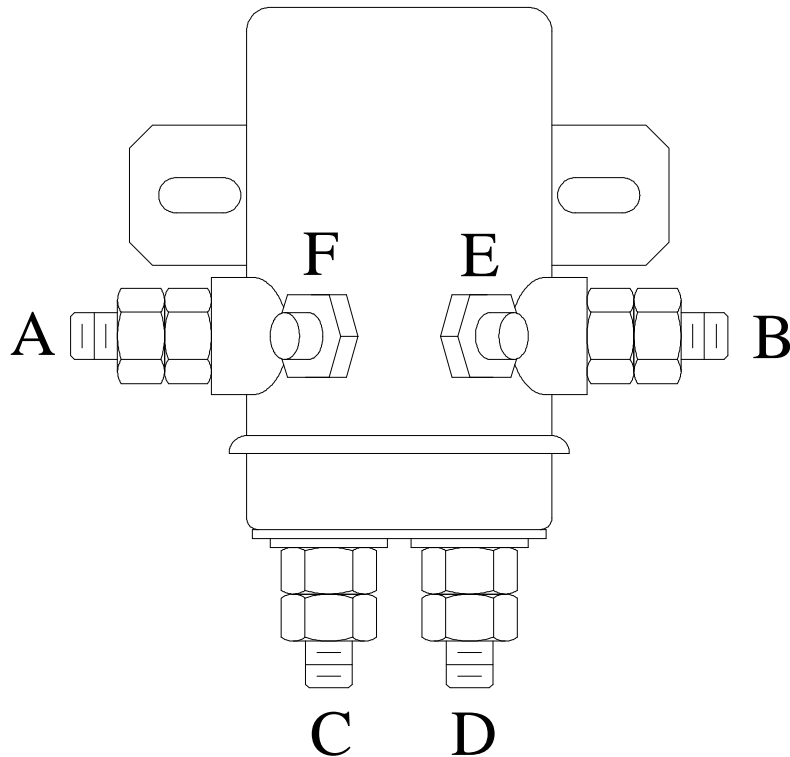

LOAD CHART

2703 SERIES

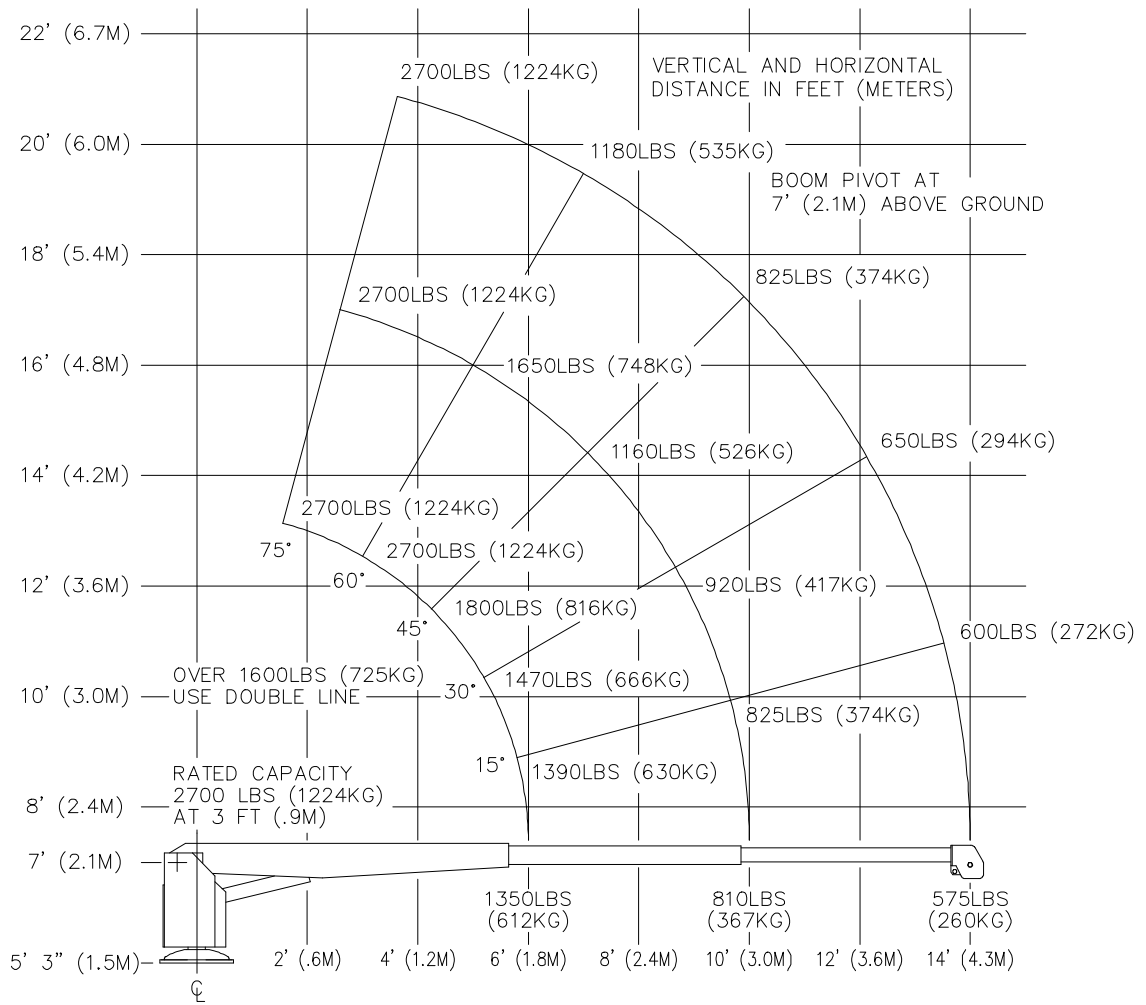

2703 SERIES LOAD CHART



AUTO CRANE COMPANY

P. O. BOX 581510 • TULSA, OKLAHOMA 74158

Limited Warranty

Auto Crane will warranty to consumer for a period of twelve months from date of purchase that each new Auto Crane product it sells will be free under normal use and service, from defects in material and workmanship. Date of purchase will be honored as either date of purchase by distributor or his date of sale of the product as substantiated by Distributor Delivery Report.

Obligation of Auto Crane under this warranty is limited to replacement or repair of parts that appear to manufacturer after review and / or inspection to be defective. This warranty does not obligate Auto Crane to bear the cost of labor or transportation charges in connection with the replacement or repair of defective parts. Responsibility for customer's claims arising from misapplication, abuse, misuse or alteration of equipment or parts lies with the distributor or user and no warranty obligation is assumed in the circumstances by Auto Crane.

Auto Crane will in no event be liable for any consequential damages or contingent liabilities arising out of the failure of any Auto Crane product or parts to operate properly.

Auto Crane makes no warranty in respect to component accessories, same being subject to the warranties of their respective manufacturers.

If field service, at the request of buyer, is rendered and fault is found not to be with Auto Crane's product, the buyer shall pay the time and expense of the field representative. Claims for service labor or other expenses that have been incurred by the buyer without approval or authorization of Auto Crane will not be accepted.

AUTO CRANE COMPANY IS UNDER NO OBLIGATION TO EXTEND THIS WARRANTY TO ANY CUSTOMER FOR WHICH AN AUTO CRANE WARRANTY REGISTRATION CARD HAS NOT BEEN COMPLETED AND MAILED TO AUTO CRANE COMPANY WITHIN FIFTEEN (15) DAYS AFTER DATE OF PURCHASE.