

OWNERS MANUAL

4004EH

REVISION 2/2000

PART NO. 999980

SERIAL NO. _____

AUTO CRANE COMPANY

PO BOX 580697, TULSA, OK 74158-0697
4707 N. MINGO ROAD, TULSA, OK 74117-5904
PHONE (918) 836-0463
FAX (918) 834-5979
<http://www.autocrane.com>

!! DISTRIBUTORS !!

**PROTECT YOUR CUSTOMER'S WARRANTY!
SUBMIT DELIVERY REPORT WITHIN 15 DAYS.**

Mail to: Auto Crane Company
P.O. Box 580697
Tulsa, OK 74158-0697

Or Fax to: 918/834-5979

Protect your customers warranty - Submit within 15 days from delivery date.



AUTO CRANE COMPANY

**DISTRIBUTOR
DELIVERY REPORT**

DISTRIBUTOR _____		OWNER _____	
ADDRESS _____		CITY/STATE _____	
CITY/STATE/ZIP _____		BUSINESS _____	
MODEL #	SERIAL #	DATE DELIVERED	UNIT DESTINATION

IMPORTANT: ATTACH SIGNED COPY OF CUSTOMER INVOICE / DELIVERY RECEIPT

AC-109 REPORT AUTHORIZED BY: _____

*** REGISTER ONE UNIT ONLY PER CARD ***

WARNINGS - READ THIS PAGE!

WARNING! Federal law (49 cfr part 571) requires that the Final Stage Manufacturer of a vehicle certify that the vehicle complies with all applicable federal regulations. Any modifications performed on the vehicle prior to the final stage are also considered intermediate stage manufacturing and must be certified as to compliance. The installer of this crane and body is considered one of the manufacturers of the vehicle. As such a manufacturer, the installer is responsible for compliance with all applicable federal and state regulations, and is required to certify that the vehicle is in compliance.

WARNING! It is the further responsibility of the installer to comply with the OSHA Truck Crane Stability Requirements as specified by 29 CFR part 1910.180 (C) (1).

WARNING! NEVER OPERATE THE CRANE NEAR ELECTRICAL POWER LINES! Death or serious injury will result from boom, line, or load contacting electric lines. Do not use crane within 10 feet (3.05m) of electric power lines carrying up to 50,000 volts. One foot additional clearance is required for every additional 30,000 volts or less.

WARNING! NEVER

- v **EXCEED** load chart capacities (centerline of rotation to hoist hook).
- v un-reel last 5 wraps of cable from drum!
- v wrap cable around load!
- v attempt to lift or drag a load from the side! The boom can fail far below its rated capacity.
- v weld, modify, or use unauthorized components on any Auto Crane unit! This will void any warranty or liability. Also failure of the crane may result.
- v place a chain link on the tip of the hook and try to lift a load!
- v use a sling bar or anything larger than the hook throat that could prevent the hook latch from closing, thus negating the safety feature!
- v hold on any pendant Select Switch that will cause unsafe operating conditions!

WARNING! In using a hook with latch, **ALWAYS** make sure that the hook throat is closed before lifting a load! Proper attention and common sense applied to the use of the hoist hook and various slings will prevent possible damage to material being hoisted and may prevent injury to personnel.

WARNING! Failure to correctly plumb and wire crane can cause inadvertent operation and damage to crane and/or personnel!

WARNING! Auto Crane Company remote controlled cranes are not designed or intended to be used for any applications involving the lifting or moving of personnel.

WARNING! ALWAYS operate the crane in compliance with the load capacity chart. **Do not use** the overload shutdown device to determine maximum rated loads, if your crane is equipped with this type of device.

4004EH SERIES - OWNER'S MANUAL
TABLE OF CONTENTS

	PAGE
1 INTRODUCTION	1-1.0.0
2 OPERATING PRACTICES & WARNINGS	1-2.0.0
3 OPERATION OF UNIT / OUTRIGGERS	1-3.0.0
4 QUALIFICATIONS FOR OPERATORS	1-4.0.0
5 INSPECTION, TESTING, & MAINTENANCE	1-5.0.0
6 LIFE OF WIRE LINE / WIRE LINE LUBRICATION	1-6.0.0
7 SAFETY DECAL SECTION	1-7.0.0
8 LUBRICATION & MAINTENANCE SCHEDULE	1-8.0.0
9 INSTALLATION	2-1.0.0
10 GENERAL ASSEMBLY	3-1.0.0
11 2-BLOCK ASSEMBLY	3-4.0.0
12 HOIST ACTUATOR ASSEMBLY	3-5.0.0
13 AUTOMATIC SAFETY BRAKE	3-6.0.0
14 TURNER ASSEMBLY	3-7.0.0
15 TRAVELING BLOCK ASSEMBLY	3-8.0.0
16 SOLENOID ASSEMBLY	3-9.0.0
17 GENERAL DIMENSIONS	4-1.0.0
18 ELECTRICAL SECTION	5-1.0.0
19 HYDRAULIC SECTION	6-1.0.0
20 LOAD CHART	8-1.0.0
21 WARRANTY	LAST PAGE

INTRODUCTION

4004EH SERIES

Auto Crane products are designed to provide many years of safe, trouble-free, dependable service when properly used and maintained.

To assist you in obtaining the best service from your crane and to avoid untimely crane and/or vehicle failure, this manual provides the following operating and service instructions. It is **specifically recommended** that all operating and service personnel consider this manual as mandatory material for reading and study before operating or servicing Auto crane products. It is **highly recommended** that crane owners, equipment managers and supervisors also read this manual.

Auto Crane has incorporated several safety features in the 4004EH series cranes for your protection. The choice of materials and the design of the electrical system minimizes weight and lengthens durability. The hydraulic components meet or exceed a **3.5:1 safety factor**. Holding valves prevent the load from dropping if a hose should fail. The reservoir has a **40 μ air filter** in the filler cap. The pump has a **100 mesh strainer** in the suction line.

For your convenience the overall dimensions of the 4004EH series crane are in the General Dimension Section. Maximum turning radius at both the hoist motor and the rotation motor are also on that drawing.

Remember, the crane adds weight to the vehicle. Adding weight may change the driving and riding characteristics of the vehicle unless the appropriate overload spring(s) are installed on the truck. The payload of the vehicle is reduced by the weight of the crane. The operator should exercise care when loading the vehicle. Distributing the payload on the vehicle evenly will greatly improve the driving and riding characteristics of the vehicle. **A minimum G.V.W. of 10,500 lbs. with two rear jacklegs (or outriggers) is recommended for mounting the 4004EH series cranes.**

The 4004EH series cranes are attached directly to your 12 volt truck electrical system. The power cable and retaining clips are included with the crane. A typical power cable mounting and hookup is shown in the installation section. The performance of your new crane depends on the truck electrical system. The use of maintenance free batteries is **NOT** recommended for use with any Auto Crane product. The recommended alternator and battery that will give the longest life with the most useful duty cycle is a 60 amp. alternator with a 120 minute reserve capacity, deep cycle battery. These specifications should be considered minimum.

Auto Crane Company issues a limited warranty certificate with each unit sold. See last page for warranty policy.

It has always been Auto Crane Company policy to handle all warranty claims we receive as promptly as possible. If a warranty claim involves discrepant material or workmanship, Auto Crane will take immediate corrective action. It is understandable that Auto Crane company cannot assume responsibility of liability when it is obvious that our products have been abused, mis-used, overloaded or otherwise damaged by inexperienced persons trying to operate the equipment without reading the manual.

Auto Crane will not assume responsibility or liability for any modifications or changes made to unit, or installation of component parts done without authorization.

Auto Crane maintains a strong distributor network and a knowledgeable Customer Service Department. In most cases, an equipment problem is solved via phone conversation with our customer service department. The customer service department also has the ability to bring a local distributor, a regional sales manager, or a factory serviceman into the solution of an equipment problem. If, through no fault of Auto crane company, it is necessary to send an experienced factory serviceman on a field service call, the rates stated in the Auto Crane Distributor's Flat Rate Manual will apply.

Auto Crane Company's extensive Research and Development Program allow our customers to use the best equipment on the market. Our Engineering Staff and our knowledgeable sales people, are always available to our customers in solving crane and winch-type application problems. When in doubt, call the Auto Crane factory.

DISTRIBUTOR ASSISTANCE:

Should you require any assistance not given in this manual, we recommend that you consult your nearest Auto Crane Distributor. Our distributors sell authorized parts and have service departments that can solve almost any needed repair.

NOTE: THIS MANUAL SHOULD REMAIN WITH THE CRANE AT ALL TIMES.

This manual does not cover all maintenance, operating, or repair instructions pertinent to all possible situations. If you require additional information, please contact the **Auto Crane Company** at the following telephone number: **(918) 836-0463**. The information contained in the manual is in effect at the time of this printing. Auto Crane Company reserves the right to update this material without notice or obligation.

GENERAL SPECIFICATIONS

4004EH SERIES

DIMENSIONS

Width: 21 in (.53 m)
Height: 32.50 in (.83 m)
Length: 11 ft 8 5/16 in (3.35 m)
Weight: 950 lbs (430 kg)
[Add 5 lbs (2.25 kg) for cable length
of 75 feet (23 m)]

CAPACITY

16,000 ft lbs (2.31 ton/m)
[ft lbs = horizontal distance from centerline of
rotation to free hanging weight (feet) x amount
of weight (pounds)]
See **Load Chart** section.

REACH

Main boom reaches 8 ft
Power boom will extend to 12 ft
Manual boom will extend to 16 ft

CABLE

80 ft (24.3 m) of 5/16 in (7.93 mm) diameter
aircraft quality cable is standard [75 ft (22.86
m) optional].

CHASSIS REQUIREMENTS

10,500 lbs (4,763 kg) GVWR minimum

HYDRAULIC SYSTEM

Pressure: 2200psi (15,169 kPa) relief setting

Flow: 5 gpm (19 lpm)

Filtration: High pressure 10 micron in
manifold

Oil Type: 10w Hydraulic Oil
[Mobile DTE 13, Sun 2015,
Dextron II]

ELECTRICAL SYSTEM REQUIREMENTS

Control voltage: 12 volt DC

Alternator: 90 amp (minimum)

Battery: 100 minute reserve
capacity (minimum)
Maintenance type

--- IMPORTANT ---

OPERATING PRACTICES & WARNINGS

1. Make certain the vehicle meets minimum chassis requirements. (These requirements do not guarantee unit stability)
2. Make certain the crane is installed per factory specifications. Contact your local Distributor or the Auto Crane factory if any questions arise.
3. Keep the vehicle in as level a position as possible while loading or unloading.
4. **ALWAYS** set the vehicle emergency brake before beginning crane operations.
5. **ALWAYS** use outriggers from vehicle to the ground during crane operation. Make sure they are firmly positioned on solid footings.
6. All load ratings are based on crane capacity, **NOT** truck/crane stability.
7. Keep objects and personnel clear of crane path during operation.
8. Keep hoist cable pulled tight at all times.
9. **REMEMBER**, in lifting a heavy load, the weight can create enough tipping momentum to overturn the vehicle.
10. **ALWAYS** keep load as close to ground as possible.
11. Oil gears as required.
12. Periodic adjustment of hoist worm brake may be required (see automatic safety brake drawing in this manual).
13. Hydraulic hoses need to be inspected frequently for signs of deterioration, and be replaced as required.
14. The hoist hook is an important item that an operator should consider and use properly. It should be checked on a daily basis for distortion or cracks.
15. **ALWAYS** store outriggers before road travel.
16. **WARNING! NEVER OPERATE THE CRANE NEAR ELECTRICAL POWER LINES!** Death or serious injury will result from boom, line, or load contacting electric lines. Do not use crane within 10 feet (3.05m) of electric power lines carrying up to 50,000 volts. One foot additional clearance is required for every additional 30,000 volts or less.
17. **WARNING! NEVER EXCEED** load chart capacities (centerline of rotation to hoist hook).
18. **WARNING! NEVER** un-reel last 5 wraps of cable from drum!
19. **WARNING! NEVER** wrap cable around load!
20. **WARNING! NEVER** attempt to lift or drag a load from the side! The boom can fail far below its rated capacity.
21. **WARNING! NEVER** weld, modify, or use unauthorized components on any Auto Crane unit! This will void any warranty or liability. Also failure of the crane may result.
22. **WARNING! NEVER** place a chain link on the tip of the hook and try to lift a load!
23. **WARNING! NEVER** use a sling bar or anything larger than the hook throat that could prevent the hook latch from closing, thus negating the safety feature!
24. **WARNING!** In using a hook with latch, **ALWAYS** insure that the hook throat is closed before lifting a load! Proper attention and common sense applied to the use of the hoist hook and various slings will prevent possible damage to material being hoisted and may prevent injury to personnel.
25. **WARNING! NEVER** hold any pendant Select Switch on that will cause unsafe operating conditions!

WARNING!

Auto Crane Company remote controlled, stiff boom cranes are not designed or intended to be used for any applications involving the lifting or moving of personnel.

--- IMPORTANT --- OPERATION OF UNIT

26. Make sure this manual has been thoroughly read by all crane operating personnel and supervisors.
27. A routine inspection of the crane should be mandatory before each operating day. Any defects should be corrected immediately.
28. At a job site the vehicle should be positioned so that the crane can adequately reach the load within the rated capacity (centerline of rotation to hoist hook).
29. Keep the vehicle as level as possible during operation.
30. For electric cranes, **engage emergency brake** and leave ignition on with transmission in neutral (or in park for automatic transmissions). Activate any crane power switches. For Auto Crane units requiring battery and hydraulic operation, **engage emergency brake**, place gear selector in neutral, press clutch, activate PTO, release clutch and after hydraulic fluid is warm, set throttle control to proper engine speed.
31. Always use outriggers from the truck to the ground. Be sure these are firm and adequately positioned. When rotating, **keep load as low to the ground as possible**.
32. Remove pendant control from cab or storage area. On smaller units, plug pendant into receptacle on crane. On larger units, remove pendant control from guard and unwrap cable from boom. Do not operate crane until cable is unwound completely. On all cranes, detach hook from dead man. Crane is now ready for operation.
33. Always boom up before rotating so the boom will clear the required boom support.
34. When extending the boom, always maintain clearance between the boom crown and the traveling block or hoist hook.
35. Always observe safe and practical operation to avoid possible accidents. Refer to Safety Tips and Precautions.
36. After completing lifting operations, return the boom to stowed position on the boom support. Avoid unneeded pressure on the boom support.
37. Store pendant control on proper location (in cab or on crane).
38. Return outriggers to stowed position. Make sure they are pinned in place or jacklegs are returned to compartment.
39. Check work area for any tools or equipment not stored.
40. Release throttle control, depress clutch and disengage PTO. Deactivate any crane power switches.
41. Report any unusual occurrence during crane operation that may indicate required maintenance or repair.
42. **NEVER** use two cranes to support a load too large for either crane.
43. Spray all electrical equipment with special corrosion resistant coating. This eliminates rust or corrosion due to melting and freezing action of condensation.

OPERATION OF OUTRIGGERS

For hydraulic outriggers:

1. Shift crane/outrigger control valve to "outrigger" position.
2. While operating the outrigger control valves (located on the outrigger cylinders) simultaneously operate the boom-up control switch. This will allow the hydraulic system to build pressure.
3. After outriggers are positioned, return crane/outrigger selector to "crane" position.
4. Crane is now ready to operate.

For manual outriggers:

1. Pull lock pins to release jack leg or drop down outrigger and move to outermost lock position.
2. Make sure lock pins are reinstalled properly.
3. Lower outrigger pad to firm ground and adjust foot to take out slack.
4. Crane is now ready to operate.

QUALIFICATIONS FOR AND CONDUCT OF OPERATORS AND OPERATING PRACTICES

OPERATORS

- 1 Crane operation shall be limited to personnel with the following minimum qualifications:**
 - A. designated persons
 - B. trainees under the direct supervision of a designated person
 - C. maintenance and test personnel (when it is necessary in the performance of their duties)
 - D. inspectors (crane).
- 2 No one other than the personnel specified above shall enter the operating area of a crane with the exception of persons such as oilers, supervisors, and those specified persons authorized by supervisors whose duties require them to do so and then only in the performance of their duties and with the knowledge of the operator or other persons.**

QUALIFICATIONS FOR OPERATORS

- 3 Operators shall be required by the employer to pass a practical operating examination. Qualifications shall be limited to the specific type of equipment for which examined.**
- 4 Operators and operator trainees shall meet the following physical qualifications:**
 - A. Vision of at least 20/30 Snellen in one eye and 20/50 in the other, with or without corrective lenses.
 - B. Ability to distinguish colors, regardless of position, if colors differentiation is required for operation.
 - C. Adequate hearing with or without hearing aid for the specific operation.
- 5 Evidence of physical defects or emotional instability which render a hazard to operator or others, which in the opinion of the examiner could interfere with the operator's performance may be sufficient cause for disqualification. In such cases, specialized clinical or medical judgment and tests may be required.**
- 6 Evidence that the operator is subject to seizures or loss of physical control shall be sufficient reason for disqualification. Specialized medical tests may be required to determine these conditions.**

- 7 Operators and operator trainees should have normal depth perception, coordination, and no tendencies to dizziness or similar undesirable characteristics.**
- 8 In addition to the above listed requirements, the operator shall:**
 - A. Demonstrate the ability to comprehend and interpret all labels, operator's manuals, safety codes and other information pertinent to correct crane operations.
 - B. Possess knowledge of emergency procedures and implementation of same.
 - C. Demonstrate to the employer the ability to operate the specific type of equipment.
 - D. Be familiar with the applicable safety regulations.
 - E. Understand responsibility for maintenance requirements of crane.
 - F. Be thoroughly familiar with the crane and its control functions.
 - G. Understand the operating procedures as outlined by the manufacturer.

CONDUCT OF OPERATORS

- 9 The operator shall not engage in any practice which will divert his attention while actually operating the crane.**
- 10 Each operator shall be responsible for those operations under the operator's direct control. Whenever there is any doubt as to safety, the operator shall consult with the supervisor before handling the loads.**
- 11 The operator should not leave a suspended load unattended unless specific precautions have been instituted and are in place.**
- 12 If there is a warning sign on the switch or engine starting controls, the operator shall not close the switch or start the engine until the warning sign has been removed by the appointed person.**
- 13 Before closing the switch or starting the engine, the operator shall see that all controls are in the "OFF" or neutral position and all personnel are in the clear.**
- 14 If power fails during operation, the operator shall:**
 - A. move power controls to the "OFF" or neutral position.

QUALIFICATIONS FOR AND CONDUCT OF OPERATORS AND OPERATING PRACTICES

B. land the suspended load and boom, if practical.

15 The operator shall be familiar with the equipment and its proper care. If adjustments or repairs are necessary, the operator shall report the same promptly to the appointed person, and shall also notify the next operator.

16 All controls shall be tested by the operator at the start of each shift. If any controls do not operate properly, they shall be adjusted or repaired before operations are begun.

17 Stabilizers shall be visible to the operator while extending or setting unless operator is assisted by a signal person.

OPERATING PRACTICES

HANDLING THE LOAD

18 Size of load

- A. No crane shall be loaded beyond the rated load except for test purposes.
- B. The load to be lifted is to be within the rated load of the crane and its existing configuration.
- C. When loads which are not accurately known are to be lifted, the person responsible for the job shall ascertain that the weight of the load does not exceed the crane rated load at the radius at which the load is to be lifted.

19 Attaching the load

- A. The load shall be attached to the hook by means of slings or other devices of sufficient capacity.
- B. Hoist rope shall not be wrapped around the load.

20 Moving the load

- A. The operator shall determine that:
- B. The crane is level and, where necessary, the vehicle/carrier is blocked properly.
- C. The load is well secured and balanced in the sling or lifting device before it is lifted more than a few inches.
- D. Means are provided to hold the vehicle stationary while operating the crane.
- E. Before starting to lift, the hook shall be brought over the load in such a manner as to minimize swinging.

F. During lifting care shall be taken that:

- 1. **there is no sudden acceleration or deceleration of the moving load.**
- 2. **load, boom or other parts of the crane do not contact any obstruction.**

G. Cranes shall not be used for dragging loads sideways.

H. This standard recognizes that articulating boom cranes are designed and intended for handling materials. They do not meet personnel lift or elevator requirements. Therefore, no lifting, lowering, swinging or traveling shall be done while a person is on the hook or load. Hook attached suspended work platforms (baskets) shall not be used with cranes covered by this standard. Work platforms attached to the boom must be approved by crane manufacturer.

I. The operator should avoid carrying loads over people.

J. When the crane is so equipped, the stabilizers shall be fully extended and set. Blocking under stabilizers shall meet the requirements as follows:

- 1. **strong enough to prevent crushing.**
- 2. **of such thickness, width and length as to completely support the stabilizer pad.**

K. Firm footing under all tires, or individual stabilizer pads should be level. Where such a footing is not otherwise supplied, it should be provided by timbers, cribbing, or other structural members to distribute the load so as to not exceed allowable bearing capacity or the underlying material.

L. In transit, the boom shall be carried in stowed position.

M. When rotating the crane, sudden starts and stops shall be avoided. rotational speed shall be such that the load does not swing out beyond the radius at which it can be controlled.

N. The crane shall not be transported with a load on the hook unless recommended by the manufacturer.

O. No person should be permitted to stand or pass under a suspended load.

21 Stowing procedure. Follow the manufacturer's procedure and sequence when stowing and un-stowing the crane.

QUALIFICATIONS FOR AND CONDUCT OF OPERATORS AND OPERATING PRACTICES

MISCELLANEOUS

OPERATING NEAR ELECTRICAL POWER LINES

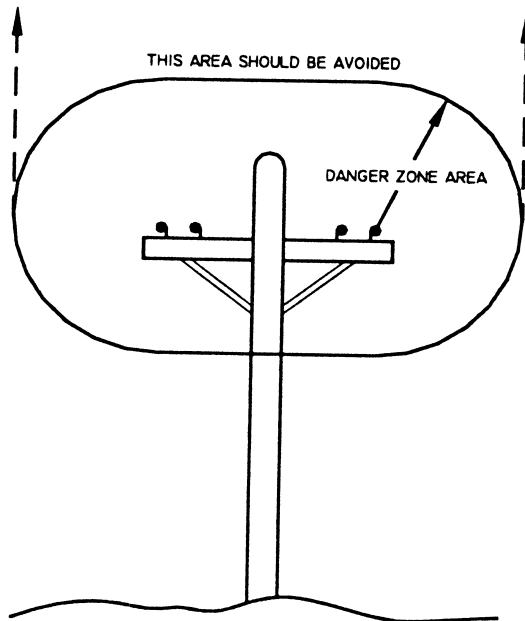

22 Cranes shall be operated so that no part of the crane or load enters into the danger zone shown above.

EXCEPTIONS

- A. The danger zone may be entered after confirmation by an appointed person that the electrical distribution and transmission lines have been de-energized and visibly grounded at the point of work; or
- B. The danger zone may be entered if insulating barriers (not a part of nor an attachment to the crane) have been erected to prevent physical contact with the lines.

23 For lines rated 50 kV or below, minimum clearance between the lines and any part of the crane or load (including handling appendages) shall be 10 ft. (3m). For higher voltages, see Table 1.

24 Caution shall be exercised when working near overhead lines, because they can move horizontally or vertically due to wind, moving the danger zone to new positions.

25 In transit with no load and boom lowered the clearance shall be specified in Table 1.

26 A qualified signalperson shall be assigned to observe the clearance and give warning before approaching the above limits.

- A. Any overhead wire shall be considered to be an energized line unless and until the person owning such line or the electrical utility authorities verify that it is not an energized line.
- B. Exceptions to this procedure, if approved by the administrative or regulatory authority if the alternate procedure provides equivalent protection and set forth in writing.
- C. Durable signs shall be installed at the operator's station and on the outside of the crane, warning that electrocution or serious bodily injury may occur unless a minimum clearance of 10 ft. (3.0m) between the crane or the load being handled and energized power lines. Greater clearances are required because of higher voltage as stated above. These signs shall be revised but not removed when local jurisdiction requires greater clearances.

TABLE 1

normal voltage, kV (phase to phase)		minimum required clearance	
		ft	(m)
<u>when operating near high voltage power lines</u>			
over	to 50	10	(3.05)
over	50 to 200	15	(4.6)
over	200 to 350	20	(6.1)
over	350 to 500	25	(7.62)
over	500 to 750	35	(10.67)
over	750 to 1000	45	(13.72)
<u>while in transit with no load and boom lowered</u>			
over	to 0.75	4	(1.22)
over	0.75 to 50	6	(1.83)
over	50 to 345	10	(3.83)
over	345 to 750	16	(4.87)
over	750 to 1000	20	(6.1)

INSPECTION, TESTING AND MAINTENANCE

GENERAL

INSPECTION CLASSIFICATION

27 Initial inspection. Prior to initial use, all new, altered, modified or extensively repaired cranes shall be inspected by a designated person to insure compliance with provisions of this standard.

28 Regular inspection. Inspection procedure for cranes in regular service is divided into two general classifications based upon the intervals at which inspection should be performed. The intervals in turn are dependent upon the nature of the components of the crane and the degree of their exposure to wear, deterioration, or malfunction. The two general classifications are herein designated as "frequent" and "periodic" with respective intervals between inspections as defined below.

- A. frequent inspection - daily to monthly intervals
- B. periodic inspection - one to twelve intervals, or as specifically recommended by the manufacturer

FREQUENT INSPECTION

29 Inspection shall be performed by designated personnel.

- A. control mechanisms for maladjustment interfering with proper operation - daily, when used
- B. control mechanisms for excessive wear of components and contamination by lubricants or other foreign matter
- C. safety devices for malfunction
- D. all hydraulic hoses, particularly those which flex in normal operation of crane functions, should be visually inspected once every working day, when used
- E. hooks and latches for deformation, chemical damage, cracks, and wear. Refer to ANSI/ASME B30.10
- F. rope reeving for compliance with crane manufacturer's specifications, if optional winch is used

G. electrical apparatus for malfunctioning, signs of excessive deterioration, dirt and moisture accumulation

H. hydraulic system for proper oil level and leaks daily

I. tires for recommended inflation pressure, cuts and loose wheel nuts

J. connecting pins and locking device for wear and damage

PERIODIC INSPECTION

30 Deformed, cracked or corroded members in the crane structure and carrier.

31 Loose bolts, particularly mounting bolts.

32 Cracked or worn sheaves and drums.

33 Worn, cracked, or distorted parts such as pins, bearings, shafts, gears, rollers and devices.

34 Excessive wear on brake and clutch system parts and lining.

35 Crane hooks inspected for cracks.

36 Travel steering, braking, and locking devices, for malfunction.

37 Excessively worn or damaged tires.

38 Hydraulic and pneumatic hose, fittings, and tubing inspection.

A. evidence of leakage at the surface of the flexible hose or its junction with metal and coupling

B. blistering, or abnormal deformation to the outer covering of the hydraulic or pneumatic hose

C. leakage at threaded or clamped joints that cannot be eliminated by normal tightening or recommended procedures

D. evidence or excessive abrasion or scrubbing on the outer surface of a hose, rigid tube, or fitting. Means shall be taken to eliminate the interference of

INSPECTION, TESTING AND MAINTENANCE

GENERAL

elements in contact or otherwise protect the components

necessary to determine origin of the problem before corrective action can be taken.

39 Hydraulic and pneumatic pumps and motors inspection.

- A. loose bolts or fasteners
- B. leaks at joints between sections
- C. shaft seal leaks
- D. unusual noises or vibrations
- E. loss of operating speed
- F. excessive heating of the fluid
- G. loss of pressure

40 Hydraulic and pneumatic valves inspection.

- A. cracks in valve housing
- B. improper return of spool to neutral position
- C. leaks at spools or joints
- D. sticking spools
- E. failure of relief valves to attain or maintain correct pressure setting
- F. relief valve pressure shall be checked as specified by the manufacturers

41 Hydraulic and pneumatic cylinders inspection.

- A. drifting caused by fluid leaking across piston
- B. rod seals leaking
- C. leaks at welding joints
- D. scored, nicked, or dented cylinder rods
- E. damaged case (barrel)
- F. loose or deformed rod eyes or connecting joints

42 Hydraulic filters. Evidence of rubber particles on the filter elements may indicate hose, "O" ring, or other rubber component deterioration. Metal chips or pieces on the filter may denote failure in pumps, motors, or cylinders. Further checking will be

43 Labels are to be in place and legible.

CRANES NOT IN REGULAR USE

44 A crane which has been idle for a period of over one month or more, but not less than six months, shall be given an inspection conforming with the initial-regular- frequent inspections.

45 A crane which has been idle for a period of over six months shall be given a complete inspection conforming with the initial-regular-frequent inspection requirements.

INSPECTION RECORDS

46 Dated records for periodic inspection should be made on critical items such as brakes, crane hooks, rope, hydraulic and pneumatic cylinders, and hydraulic and pneumatic relief pressure valves. Records should be kept available to an appointed person.

OPERATIONAL TESTS

47 Prior to initial use, all new, altered, modified, or extensively repaired cranes shall be tested for compliance with the operational requirements of this section, including functions such as the following:

- A. load lifting and lowering mechanisms
- B. boom lifting and lowering mechanisms
- C. boom extension and retraction mechanisms
- D. swing mechanisms
- E. safety devices
- F. operating controls comply with appropriate function labels

Operational crane test results shall be made available to an appointed person.

RATED TEST LOAD

Prior to initial use, altered, modified, or extensively repaired cranes shall be load

INSPECTION, TESTING AND MAINTENANCE

GENERAL

tested by or under the direction of an appointed person.

48 Test loads shall not exceed 110% of the manufacturer's load ratings.

49 Written reports shall be maintained showing test procedures and confirming the adequacy of repairs.

MAINTENANCE

PREVENTIVE MAINTENANCE

50 Before adjustment and repairs are started on a crane, the following precautions shall be taken as applicable:

- A. crane placed where it will cause the least interference with other equipment or operations
- B. all controls at the "off" position
- C. starting means rendered inoperative
- D. boom lowered to the ground if possible or otherwise secured against dropping
- E. relieve hydraulic oil pressure from all hydraulic circuits before loosening or removing hydraulic components

51 Warning or "OUT OF ORDER" signs shall be placed on the crane controls.

52 After adjustments and repairs have been made, the crane shall not be returned to service until all guards have been reinstalled, trapped air removed from hydraulic system (if required), safety devices reactivated, and maintenance equipment removed.

ADJUSTMENTS AND REPAIRS

53 Any hazardous conditions disclosed by the inspection requirements shall be corrected before operation of crane is resumed, Adjustments and repairs shall be done only by designated personnel.

54 Adjustments shall be maintained to assure correct functioning of components, The following are examples:

- A. functional operating mechanism
- B. safety devices
- C. control systems

55 Repairs or replacements shall be provided as needed for operation.

The following are examples:

- A. critical parts of functional operating mechanisms which are cracked, broken, corroded, bent, or excessively worn
- B. critical parts of the crane structure which are cracked, bent, broken, or excessively corroded
- C. crane hooks showing cracks, damage, or corrosion shall be taken out of service. Repairs by welding are not recommended

56 Instructions shall be provided by the manufacturer for the removal of air from hydraulic circuits.

LUBRICATION

All moving parts of the crane, for which lubrication is specified, should be regularly lubricated per the manufacturer's recommendations and procedures.

ROPE INSPECTION

57 Frequent Inspection

- A. All running ropes in service should be visually inspected once each working day. A visual inspection shall consist of observation of all rope which can be in use during the days operations. These visual observations should be considered with discovering gross damage such as listed below, which may be an immediate hazard.

- 1. distortion of the rope such as kinking, crushing, un-stranding, birdcaging, main strand displacement, or core protrusion. Loss of rope diameter in a short length or unevenness of outer strands should be replaced**

- 2. general corrosion**

INSPECTION, TESTING AND MAINTENANCE

GENERAL

3. broken or cut strands;
4. number, distribution and type of visible broken wires. When such damage is discovered, the rope shall either be removed from service or given as inspection.

B. Care shall be taken when inspecting sections of rapid deterioration such as flange points, crossover points, and repetitive pickup points on drums.

58 Periodic inspection

A. The inspection frequency shall be determined by a qualified person and shall be based on such factors as:

1. expected rope life as determined by experience on the particular installation or similar installations
2. severity of environment
3. percentage of capacity lifts
4. frequency rates of operation
5. exposure to shock loads

Inspection need not be at equal calendar intervals and should be more frequent as the rope approaches the end of its service life. This inspection shall be made at least annually.

B. Periodic inspection shall be performed by a designated person. This inspection shall cover the entire length of the rope. Only the surface wires need be inspected. No attempt should be made to open the rope. Any deterioration results in appreciable loss of original strength, such as described below, shall be noted and determination made as to whether use of the rope would constitute a hazard: points listed above reduction of rope diameter below nominal diameter due to loss of core support, internal or external corrosion, or wear of outside wires; severely corroded, cracked, bent, worn or improperly applied connections;

C. Care shall be taken when inspecting sections subject to rapid deterioration such as the following:

1. sections in contact with saddles, equalizer sheaves, or other sheaves where rope travel is limited
2. sections of the rope at or near terminal ends where corroded or broken wires may protrude

ROPE REPLACEMENT

59 No precise rules can be given for determination of the exact time for replacement of rope, since many variable factors are involved.

Continued use in this respect depends upon good judgement by a designated person in evaluating remaining strength in a used rope after allowance for deterioration disclosed by inspection. Continued rope operation depends upon this remaining strength.

60 Conditions such as the following shall be reason for questioning continued use of the rope or increasing the frequency of inspection:

- A. in running ropes, six randomly distributed broken wires in one lay or three broken wires in one strand in one lay
- B. one outer wire broken at the contact point with the core of the rope structure and protrudes or loops out of the rope structure. Additional inspection of this section is required
- C. wear of one third of the original diameter of the outside individual wire
- D. kinking, crushing, birdcaging, or any other damage resulting in distortion of the rope structure
- E. evidence of any heat damage from any cause
- F. reduction from nominal diameter of more than 1/64 in. (0.4mm) for diameters up to and including 5/16 in. (8 mm), 1/32 in. (0.8 mm) for diameter 3/8 in. (9.5 mm) to and including 1/2 in. (13 mm), 3/64 in. (1.2 mm) for diameter 9/16 in. (14.5 mm) to and including 3/4 in. (19 mm). 1/16 in. (1.6 mm) for diameter 7/8 in. (22 mm) to and including 11/8 in. (29 mm), 3/32 in. (2.4 mm) for diameters 11/4 in. (32 mm) to and including 11/2 in. (38 mm)

INSPECTION, TESTING AND MAINTENANCE

GENERAL

G. In standing ropes, more than two broken wires in one lay in sections beyond end connections or more than one broken wire at an end connection.

H. Replacement rope shall have a strength rating at least as great as the original rope furnished or recommended by the crane manufacturer. Any deviation from the original size, grade, or construction shall be specified by a rope manufacturer, or a qualified person.

61 Rope not in regular use: all rope which has been idle for a period of a month or more due to shutdown or storage of a crane on which it is installed, shall be given and inspection in accordance with above information before it is placed in service. This inspection shall be for all types of deterioration and shall be performed by a qualified person.

62 Inspection records

A. frequent inspection- no records required

B. periodic inspections- in order to establish data as a basis for judging the proper time for replacement, a dated report condition at each periodic inspection should be kept on file. This report shall cover points of deterioration listed above.

ROPE MAINTENANCE

63 Rope should be stored to prevent damage or deterioration.

64 Unreeling or uncoiling of rope shall be done as recommended by the rope manufacturer and with care to avoid kinking or inducing twist.

65 Before cutting a rope, seizing shall be placed on each side of the place where the rope is to be cut to prevent unlaying of the strands. On pre-formed rope, one seizing on each side of the cut is required. On non-preformed ropes of 7/8 in. (22 mm) diameter or smaller, two seizings on each side of the cut are required, and for non-preformed rope 1 in. (25 mm) diameter or larger, three seizings on each side of the cut are required.

66 During installation care should be exercised to avoid dragging of the rope in the dirt or around objects which will scrape, nick crush or induce sharp bends in it.

67 Rope should be maintained in a well-lubricated condition. It is important that lubricant applied as a part of a maintenance program shall be compatible with the original lubricant and to this end the rope manufacturer should be consulted. Lubricant applied shall be the type which does not hinder visual inspection. Those sections of rope which are located over sheaves or otherwise hidden during inspection and maintenance procedures require special attention when lubricating rope. The object of rope lubrication is to reduce internal friction and to prevent corrosion.

68 When an operating rope shows greater wear or well defined localized areas than on the remainder of the rope, rope life can be extended in cases where a section at the worn end, and thus shifting the wear to different areas of the rope.

LIFE OF WIRE LINE

So many variable factors can cause the deterioration of wire line cable that it is not possible to determine a definite life expectancy. Some of these factors are:

- 1. Load being handled.**
- 2. Corrosive conditions.**
- 3. Maintenance of the unit.**
 - A. Keep the sheaves turning freely
 - B. Maintain tension on cable to insure proper spooling
 - C. Avoid kinks in cable
 - D. Avoid abrasive action and contact with sharp corners
- 4. Frequency of use.**

Auto Crane units, up to 2,400 pound ratings, use 3/16 inch diameter galvanized pre-formed 7 x 19 aircraft cable. This cable has a working strength, when new, of 4,200 pounds. It is recommended when 1,200 pound loads are exceeded to use a two part line with a traveling block. This will ensure a 3.5 to 1 safety factor when the cable is new.

Keeping the above factor of safety in mind and knowing the kind of loads that will be handled, the user can determine by inspection of the cable as to when it should be replaced.

Items to look for while inspecting the cables are:

- 1. Broken strands.**
- 2. Kinks and flattened sections.**
- 3. Corrosion and abrasion.**

WIRE LINE LUBRICATION

Lubrication of the wire line serves two important purposes: (1) helps to prevent corrosion; (2) lubricates the cable strands to reduce wear due to flexing and abrasion caused by contact with the sheaves, rollers, and cable on the drum.

PREPARATION:

Remove rust and foreign matter with a wire brush and wipe clean. Be sure cable is dry.

APPLICATION:

Method 1: A light weight motor oil may be used by dipping a brush into the lubricant and applying. In some cases, a rag or piece of sheepskin is dipped in the lubricant and used to swab the lubricant on to the rope.

Method 2: A heavier lubricant such as a grease gun lubricant may be used by applying with hands while wearing leather gloves. (Leather gloves are preferred to canvas because of greater protection and less penetration of the grease)

MAINTENANCE OF BATTERIES

Maintenance of Auto Crane unit batteries differs very little from the generally prescribed maintenance of any lead acid battery. All batteries must be kept *properly charged, properly filled with water, and relatively clean.*

Keep Properly Charged

Many things affect the proper charge to a battery, such as:

- 1 Regulator settings
- 2 Proper tightness of belts on the alternator or generator
- 3 Good, clean connections of all cables and wires at the following places:
 - A. Battery
 - B. Regulator
 - C. Starting motor
 - D. Alternator or generator
 - E. Ground connections (most important)

It is of extreme importance to keep the battery as fully charged as possible without overcharging, especially when vehicles are left outside for extended periods in extremely cold climates. A battery *can* freeze. Freezing points for various specific gravities of acid are as follows:

Specific Gravity (Corrected to 80°F)	Freezing Temp. Degrees F.
1.280	-90°F
1.250	-62°F
1.200	-16°F
1.150	5°F
1.100	19°F

As shown, a half-charged battery (about 1.200 specific gravity) cannot stand for any length of time at 20°F or it will freeze.

The *main reason* for keeping the battery as fully charged as possible without over-charging is to ensure that power is available even though the vehicle has been standing for some time.

Keep Properly Filled with Water

The battery should *always* be properly filled with water. If the electrolyte level is allowed to fall below the top of the plates, the results become threefold:

- 1 The exposed portion of the plate will become sulfated.
- 2 The portion of the plate exposed is not usable.
- 3 That portion of the acid remaining becomes more concentrated and may cause more rapid deterioration of the remaining parts of the battery.

Keep A Relatively Clean Battery

The battery should be kept clean. Batteries filled with acid and which are not in use self-discharge to a limited degree because of the nature of the materials within the battery. If dirt is allowed to collect on the top of the battery (and this dirt absorbs moisture) and electrical path can be set up between the various terminals of the battery and the ground. Once such a path has been established, the self-discharge of the battery is accelerated. This also accelerates corrosion of the battery cables at the terminals.

Periodic Maintenance is Needed

A definite program of periodic maintenance of all batteries should be conducted on a regular basis. Periodic maintenance includes:

- 1 Checking belts for tightness on the charging equipment
- 2 Checking battery electrolyte levels
- 3 Checking cables for good connections
- 4 Cleaning where corrosion is apparent

When corrosion is cleaned off, the cable terminals and battery terminals should be coated with a light coating of petroleum jelly before they are replaced. When terminals are cleaned, the top of the battery should be cleaned with a mild solution of soda water.

MAINTENANCE OF BATTERIES

Low Maintenance Batteries (Maintenance Free)

Low maintenance batteries should not be used on Auto Cranes or trucks equipped with Auto Cranes. The batteries are not designed for "deep" discharge.

Testing Your Battery

If the condition of the battery is in question, it should be removed from the vehicle, taken to the shop, and allowed to reach room temperature. It should then be recharged until specific gravity readings taken at one-half hour intervals. If the specific gravity readings are fairly uniform, the battery should be checked with a high rate tester. Use the tester in accordance with the manufacturer's instructions. The high rate tester is the best method to test a questionable battery.

If, after charging, it is noted that the specific gravity reading of one cell is 30 points less than any of the other cells, it may be assumed that the cell is bad and that the battery should be replaced. If all cells are uniform but not up to full charge, a low rate of charge

should be attempted for an extended time. This usually will recover a badly sulfated battery.

Replacing a Battery

If it is necessary to replace a battery, and a dry charge battery is used, the following procedure applies:

- 1 Fill the battery with electrolyte of the proper specific gravity.
- 2 Place the battery on charge according to the manufacturer's instructions.

It is essential that the second step above be followed to ensure that the battery going on the vehicle is fully charged.

It is also very important that the battery hold-downs be checked periodically to ensure that the batteries are properly positioned to avoid vibration problems, breakage of cables or terminals. Care must be taken to avoid cracking or breaking containers or covers by tightening hold-down fixtures excessively. They also must not be so loose that breakage results from a hold-down that is too loose.

SAFETY DECAL SECTION

PART NO.: 040517
DECAL: STAY CLEAR OF BOOM
FUNCTION: To inform the operator of the hazard of proximity or contact with the crane boom during operation.
QUANTITY: 2
PLACEMENT: Both sides of crown
(see page 1-7.3.0/1-7.4.0, Item 12)



FIG. SD-1.

PART NO.: 040518
DECAL: STAY CLEAR OF LOAD
FUNCTION: To inform the operator of the hazard of proximity or contact with the crane load during operation.
QUANTITY: 2
PLACEMENT: Both sides of crown plate
(see page 1-7.3.0/1-7.4.0, Item 13)



FIG. SD-2.

PART NO.: 040519
DECAL: SCISSORS POINT
FUNCTION: To inform the operator of possible danger at scissors point on crane.
QUANTITY: 1
PLACEMENT: Both sides of lift cylinder
(see page 1-7.3.0/1-7.4.0, Item 17)

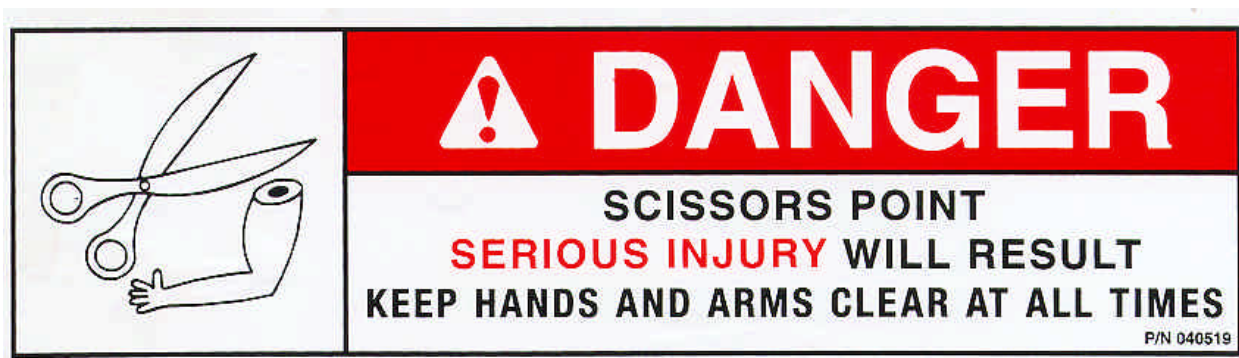

FIG. SD-3.

SAFETY DECAL SECTION

PART NO.: 040529 QUANTITY: 2
DECAL: ELECTROCUTION HAZARD PLACEMENT: Both sides of end of lower boom
FUNCTION: To inform the operator of the hazard involved with contacting electrical power lines with crane boom. (see page 1-7.3.0/1-7.4.0, Item 11)

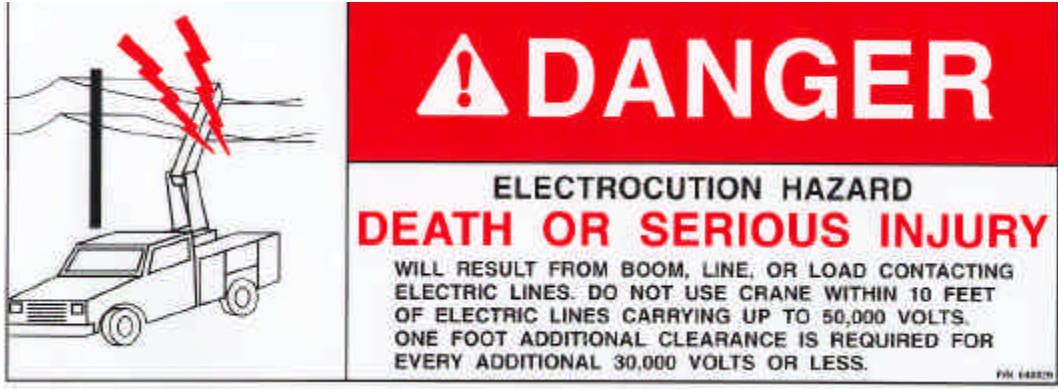

FIG. SD-4.

PART NO.: 040580
DECAL: OPERATOR TRAINING
FUNCTION: To inform the operator of the need to receive proper training before using the crane.
QUANTITY: 1
PLACEMENT: Left Sideplate (see page 1-7.3.0/1-7.4.0, Item 4)

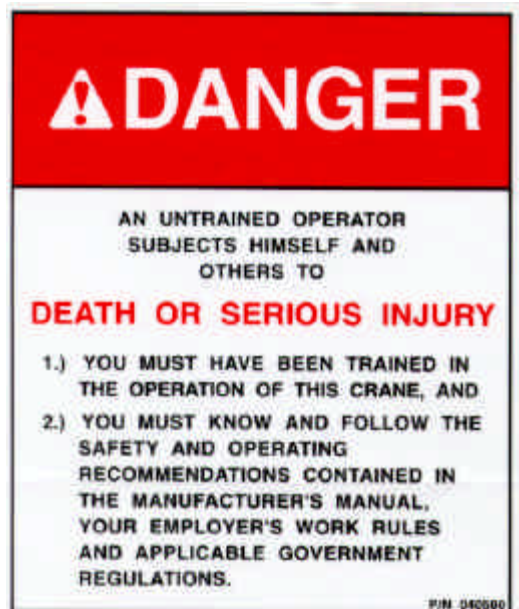

FIG. SD-5.

SAFETY DECAL SECTION

PART NO.: 040579
DECAL: OPERATION INSTRUCTIONS
FUNCTION: To inform the operator of the proper procedure to follow for safe operation of the crane.
QUANTITY: 1
PLACEMENT: Left Sideplate
(see page 1-7.3.0/1-7.4.0, Item 1)

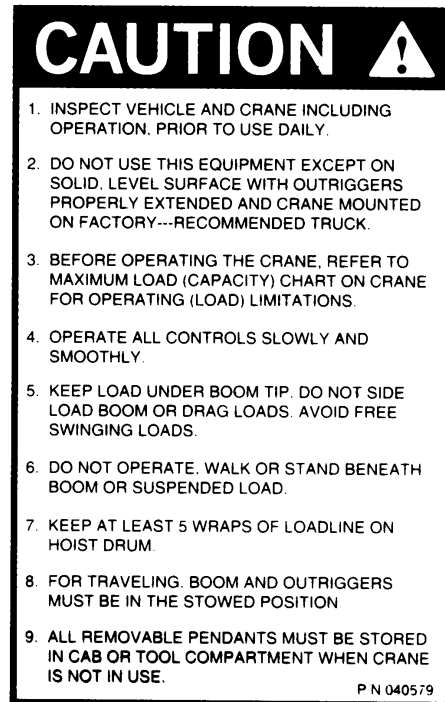

FIG. SD-6.

PART NO.: 040587
DECAL: LOAD SENSOR
FUNCTION: To inform the operator that the load sensor is pre-set and that tampering with the sensor may cause potentially hazardous situation.
QUANTITY: 1
PLACEMENT: On the lift cylinder near the load sensor
(see page 1-7.3.0/1-7.4.0, Item 15)



FIG. SD-7.

PART NO.: 040632
DECAL: TAMPERING WITH OVERLOAD DEVICE
FUNCTION: To inform the operator that tampering with the overload device may cause a unit failure or possible personnel injury.
QUANTITY: 1
PLACEMENT: Right side of lift cylinder
(see page 1-7.3.0/1-7.4.0, Item 5)



FIG. SD-8.

DECAL DRAWING

4004EH 8-12-16 BOOM

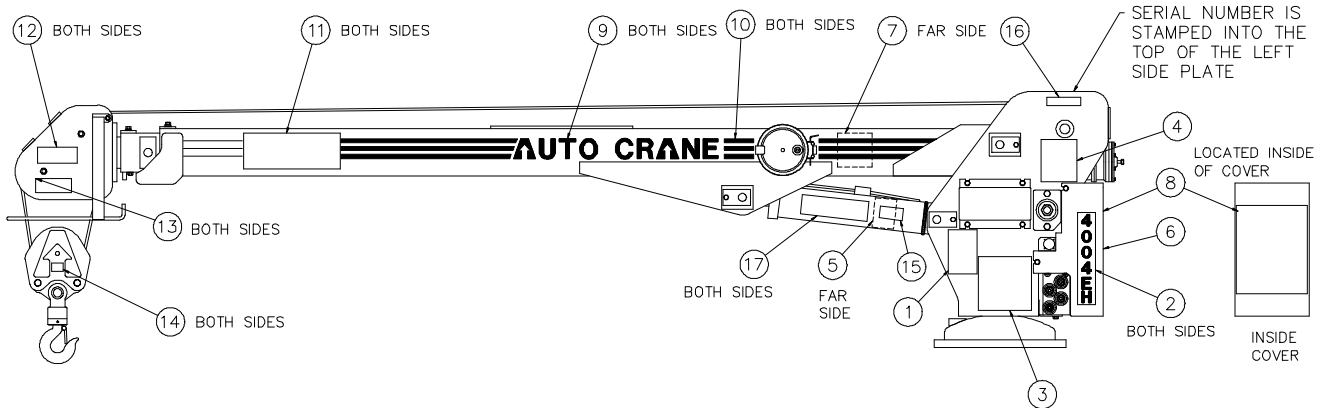

ITEM	QTY	P/N	DESCRIPTION
1	1	040579	CAUTION "INSPECT VEHICLE..." DECAL
2	2	404051	4004EH DECAL
3	1	404050	4004EH LOAD CHART (8-12-16) DECAL
4	1	040580	DANGER "AN UNTRAINED OPERATOR..." DECAL
5	1	040632	WARNING "TAMPERING WITH OVERLOAD..." DECAL
6	1	360034	LOGO DECAL
7	1	320318	ANGLE INDICATOR DECAL
8	2	040519	DANGER "SCISSORS POINT" DECAL
9	2	040624	AUTO CRANE DECAL
10	11 FT	040620	STRIPING DECAL
11	2	040529	DANGER "ELECTROCUTION HAZARD" DECAL
12	2	040517	DANGER "STAY CLEAR OF BOOM" DECAL
13	2	040518	DANGER "STAY CLEAR OF LOAD" DECAL
14	2	360480-100	BLOCK WEIGHT & MAX. LOAD DECAL
15	1	040587	WARNING "LOAD SENSOR PRESET" DECAL
16	1	330622	SERIAL NUMBER DECAL

DECAL DRAWING

4004EH 8-12 BOOM

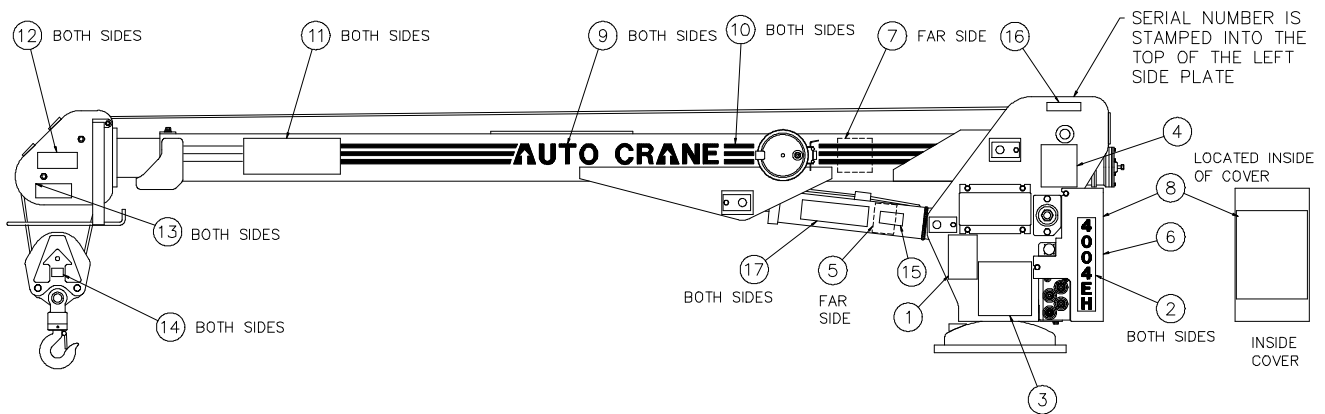

ITEM	QTY	P/N	DESCRIPTION
1	1	040579	CAUTION "INSPECT VEHICLE..." DECAL
2	2	404051	4004EH DECAL
3	1	404101	4004EH LOAD CHART (8-12) DECAL
4	1	040580	DANGER "AN UNTRAINED OPERATOR..." DECAL
5	1	040632	WARNING "TAMPERING WITH OVERLOAD..." DECAL
6	1	360034	LOGO DECAL
7	1	320318	ANGLE INDICATOR DECAL
8	2	040519	DANGER "SCISSORS POINT" DECAL
9	2	040624	AUTO CRANE DECAL
10	11 FT	040620	STRIPING DECAL
11	2	040529	DANGER "ELECTROCUTION HAZARD" DECAL
12	2	040517	DANGER "STAY CLEAR OF BOOM" DECAL
13	2	040518	DANGER "STAY CLEAR OF LOAD" DECAL
14	2	360480-100	BLOCK WEIGHT & MAX. LOAD DECAL
15	1	040587	WARNING "LOAD SENSOR PRESET" DECAL
16	1	330622	SERIAL NUMBER DECAL

LUBRICATION & MAINTENANCE SCHEDULE for 4004EH

SERVICE PERFORMED	DAILY	WEEKLY	6 MOS	YEAR	NOTES
LOAD HOOK	X				INSPECT HOOK & LATCH FOR DEFORMATION, CRACKS, & CORROSION
CABLE DRUM	X				MAKE SURE CABLE IS WOUND EVENLY ON DRUM
HOIST CABLE	X				CHECK FOR FLATTENING, KINKS, & BROKEN STRANDS, SEE MANUAL
HYDRAULIC HOSES	X				VISUAL INSPECTION
HYDRAULIC FLUID	X				CHECK FLUID LEVEL
MOUNTING BOLTS		X			CHECK-TORQUE TO 440 FT-LBS AS REQUIRED
ROTATION WORM GEAR		X			LUBE WITH MOBILTAC LL, OR LUBRIPLATE P/N 15263, OR EQUIVALENT
SHEAVE BEARINGS		X			SEALED BEARING, REPLACE IF ROUGH OR LOOSE
ALL OTHER BOLTS		X			CHECK-TIGHTEN AS REQUIRED
BOOM PIVOTS		X			GREASE WITH MOBILPLEX EP-2 OR EQUIVALENT AT ZERKS
BOOM CYLINDER		X			CHECK AROUND CYLINDER ROD FOR EXCESS FLUID LEAKAGE
BOOM CYLINDER PINS		X			GREASE WITH MOBILPLEX EP-2 OR EQUIVALENT AT ZERKS
EXTENSION DETENT PIN		X			LUBE DETENT SPRING & BALL w/ WD-40
HOIST GEARBOX			X		WORM GEAR-EP GEAR LUBE SAE 80-90, SPUR GEAR SAE 30 OIL
HYDRAULIC FLUID				X	DRAIN, FLUSH, & REFILL WITH SUN 2105 HYDRAULIC OIL, SAE 5W-20
BOOM SLIDE PADS	PADS GREASED WHEN REPLACED				
CAUTION	{ Routine maintenance insures trouble-free operation and protects your investment. All warranties are void if maintenance is neglected.				

NOTES:

- { Use only authorized parts. Any damage or malfunction caused by the use of unauthorized parts is not covered by Warranty or Product Liability.
- { Once a bolt has been torqued to its rated capacity and then removed; the bolt should be replaced with a new one.
- { Auto Crane Company recommends that this crane be serviced per "Crane Inspection Log" P/N 999978. These logs should be filled in at the intervals noted and kept as a permanent record. Additional copies are available from your local distributor.

LUBRICATION & MAINTENANCE

4004EH SERIES

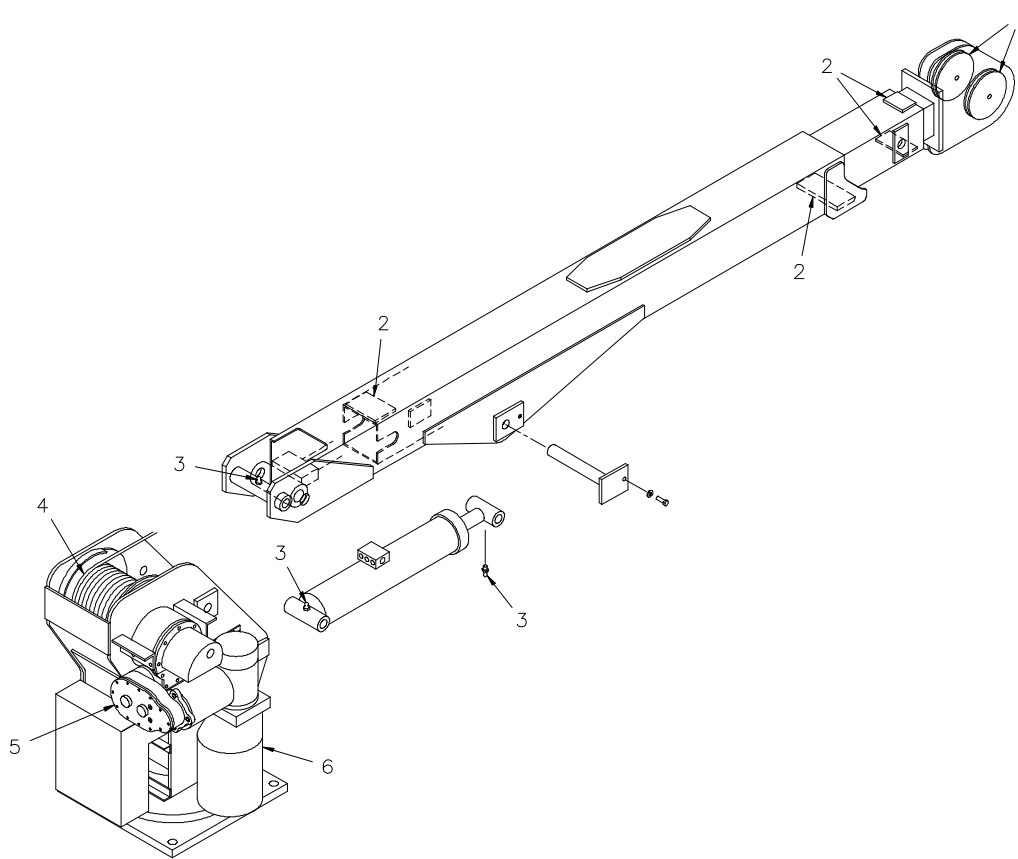

1. Sheave roller bearings: sealed type, no lube required.
2. Boom pad: if replaced, grease upon installation with chassis lubricant.
3. Pivot point grease zerks: lube once a week with Mobilplex EP-2 or equivalent.
4. Hoist roller bearings: sealed type, no lube required.
5. Hoist actuator: maintain gear box lubricant at fill plug. Use one pint of EP gear lube SAE 80-90. Replace every six months.
6. Hydraulic fluid: use DTE-13 or equivalent. Reservoir should be flushed and new fluid added once a year, or if a hydraulic failure occurs.

ASSEMBLY & INSTALLATION INSTRUCTIONS

4004EH SERIES

NOTE: For mounting bolt hole pattern - see GENERAL DIMENSIONS.

CAUTION:
BOOM MUST BE PROPERLY SECURED
IN PLACE, ON A BOOM SUPPORT
BRACKET, WHEN CRANE IS NOT IN
USE. (TO PREVENT GEAR DAMAGE)

BOOM SUPPORT BRACKET
AUTO CRANE P/N 726175

NOTICE:

WE RECOMMEND REPLACING
ANY NO-MAINTENANCE TRUCK
BATTERY WITH A MAINTENANCE
TYPE TRUCK BATTERY

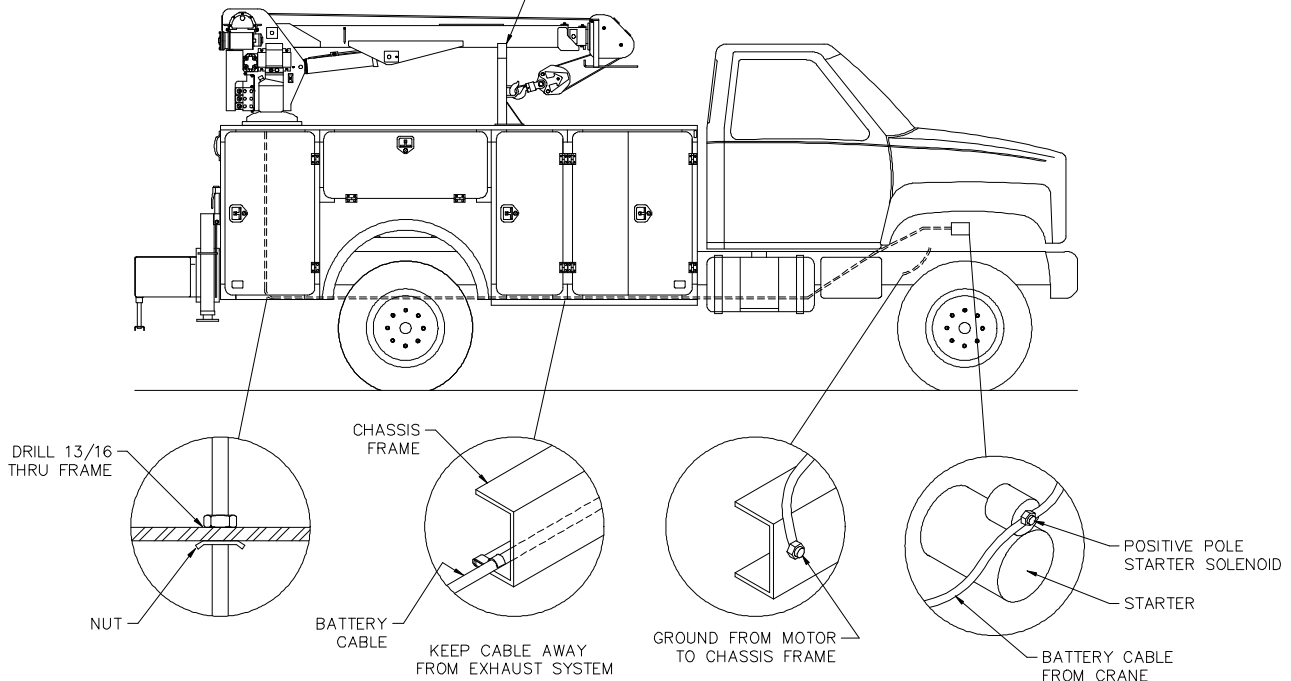

INSTALLATION - BATTERY CABLE

1. Drill 13/16" hole in floor. Install bushing, which is connected to cable, so it fits hole snug.
2. Run cable to positive battery terminal. Connect black cable to negative battery terminal or suitable chassis ground point. Locate cables so that they will be protected. Avoid sharp edges. Use the No. 083800 frame clips provided to hold cables securely in place.
3. If the battery is grounded to the engine it may be necessary to add an additional ground cable from the engine to the chassis frame to obtain maximum power at crane.

BOOM SUPPORT

4004EH SERIES

WARNING:

As with all Auto Crane power rotation units, the 4004EH does require a boom support.

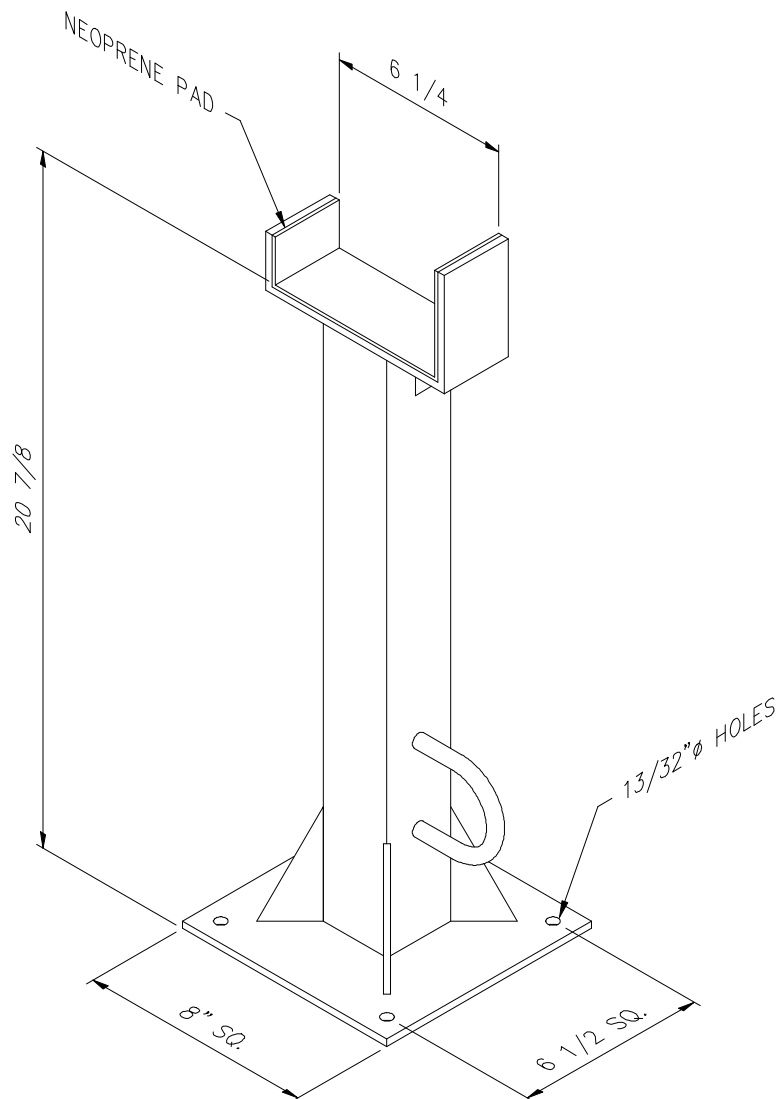

**Suggested Boom Support:
Auto Crane P/N 726175**

GENERAL ASSEMBLY - UNIT LESS BOOM

P/N 404001 - MODEL 4004EH

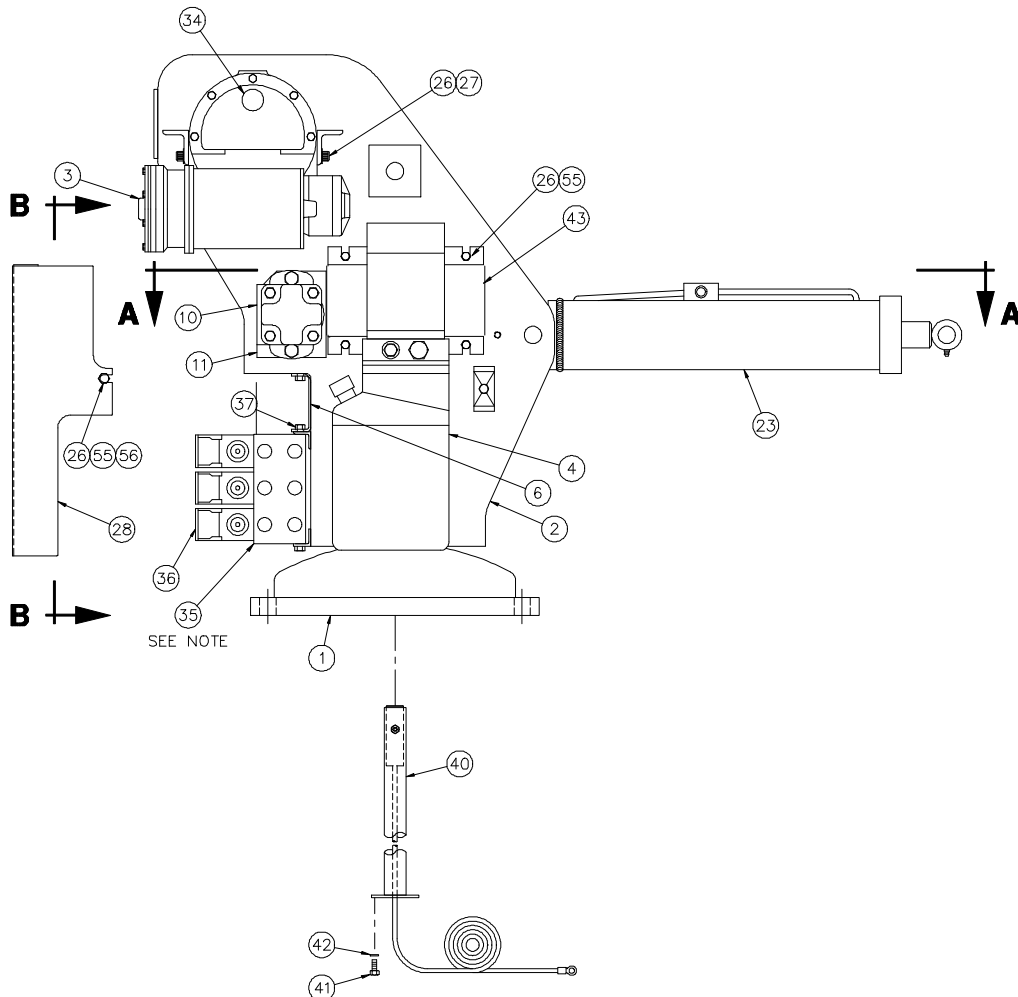
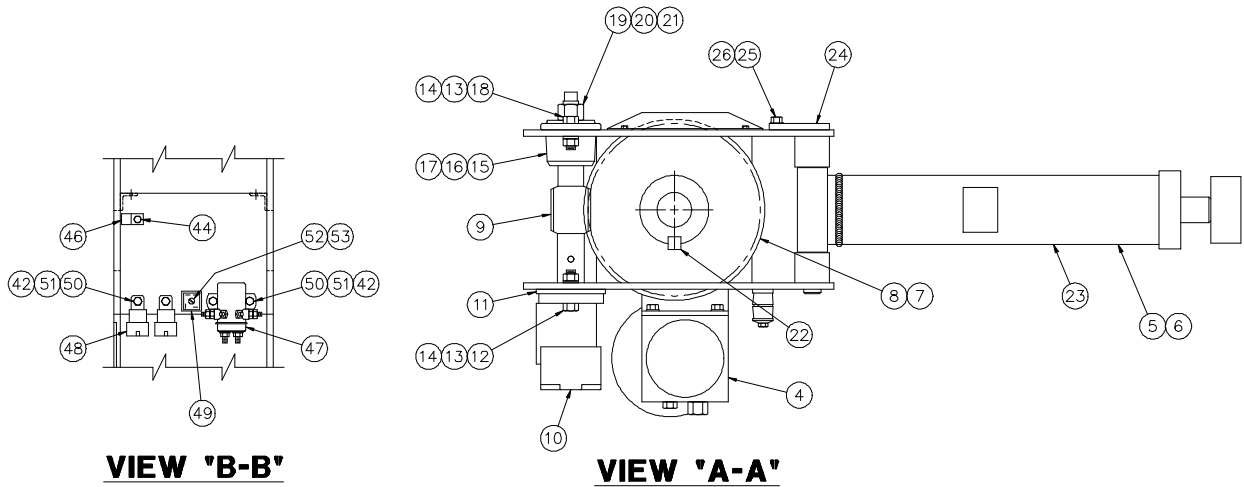

GENERAL ASSEMBLY - UNIT LESS BOOM

P/N 404001 - MODEL 4004EH

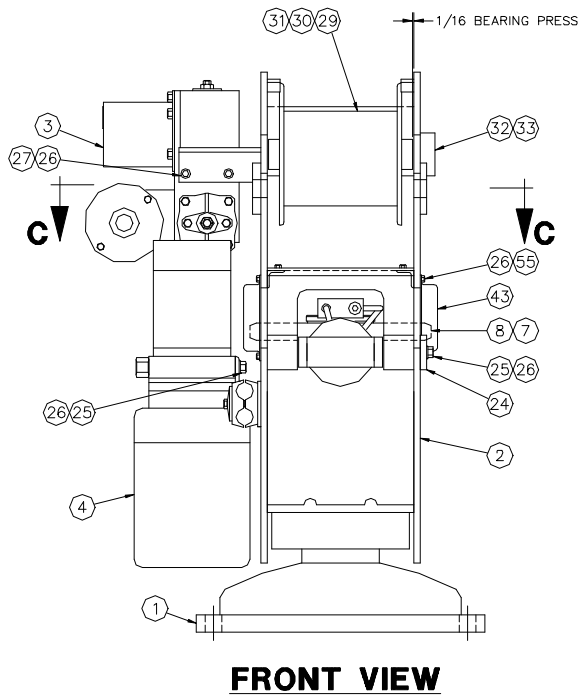
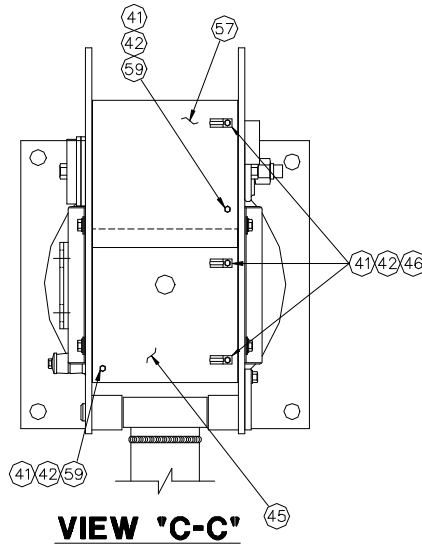

GENERAL ASSEMBLY - UNIT LESS BOOM

P/N 404001 - MODEL 4004EH

<u>ITEM</u>	<u>QTY</u>	<u>P/N</u>	<u>DESCRIPTION</u>
1	1	404025	PEDESTAL WELDMENT
2	1	404020	SIDE PLATES/QUILL HOUSING WELDMENT
3	1	404007	HOIST ACTUATOR
4	1	404008	POWER UNIT
5	2	404017	BEARING ROTATION
6	1	404124	VALVE BANK BRACKET
7	2	404028	RETAINING RING GEAR
8	1	404016	WORM GEAR
9	1	404015	WORM
10	1	480027	ROTATION MOTOR
11	2	330484	SPACER
12	2	011603	CAPSCREW 1/2 NC x 1 3/4
13	4	021500	LOCK WASHER 1/2
14	4	017701	NUT 1/2 NC
15	2	330486	OIL SEAL
16	2	330485	BEARING
17	1	330472	HOUSING
18	2	010201	CAPSCREW 1/2 NC x 1 1/2
19	1	330483	SPACER
20	1	019000	LOCK NUT 7/8 NF
21	1	239300	GREASE ZERK
22	1	340602	KEY 3/4 SQ x 1
23	1	404005	BOOM UP CYLINDER
24	1	360624	PEDESTAL/CYLINDER PIN
25	3	366158	CAPSCREW 3/8 NC x 3/4 GR8
26	7	021100	LOCK WASHER 3/8
27	4	404081	SOCKET HEAD SCREW 3/8 NC x 7/8
28	1	404135	COVER VALVE
29	1	360543	HOIST DRUM
30	1	360557	KEY 5/16 SQ x 8 1/8
31	2	480073	WINCH SHAFT SPACER
32	2	400500	BEARING
33	2	330468	SPLIT-LOCK COLLAR
34	1	360848	PLASTIC PLUG - FOR 1 HOLE

GENERAL ASSEMBLY - UNIT LESS BOOM

P/N 404001 - MODEL 4004EH

<u>ITEM</u>	<u>QTY</u>	<u>P/N</u>	<u>DESCRIPTION</u>
35	1	202710	MANIFOLD
36	3	300204	DIRECTIONAL CONTROL VALVE
37	6	002614	CAPSCREW 5/16 NC x 5/8
38	1	002900	SET SCREW 1/4 NC x 1/4
39	1	404057	POWER CABLE ASSEMBLY TO HOIST
40	1	404056	POWER CABLE ASSEMBLY
41	6	005401	CAPSCREW 1/4 NC x 5/8
42	10	020200	LOCK WASHER 1/4
43	2	404094	WORM GEAR COVER
44	12	320371	SELF TAP SCREW #10 NC x 3/4
45	1	404140	RIGHT HAND PEDESTAL WELDMENT COVER
46	3	000115	JIFFY CLIP #115
47	1	200182	12V RELAY
48	2	320355	DROP OUT RELAY
49	1	751138	25 AMP RECTIFIER BRIDGE
50	4	005604	CAPSCREW 1/4 NC x 1
51	4	015900	NUT 1/4 NC
52	1	002502	ROUND HEAD SCREW #10 NF x1 1/4
53	1	015600	NUT #10 NF
54	3	019800	LOCK WASHER #10
55	12	008401	CAPSCREW 3/8 NC x 1/2
56	2	021200	FLAT WASHER 3/8
57	1	404098	LEFT HAND PEDESTAL WELDMENT COVER
*58	4	015104	CAPSCREW 7/8 NF x 5 GR8 (not shown)
*59	4	022200	LOCK WASHER 7/8 (not shown)
*60	4	018900	NUT 7/8 NFGR8 (not shown)

* BASE MOUNTING HARDWARE TO TRUCK FRAME

PEDESTAL ASSEMBLY

MODEL 4004EH

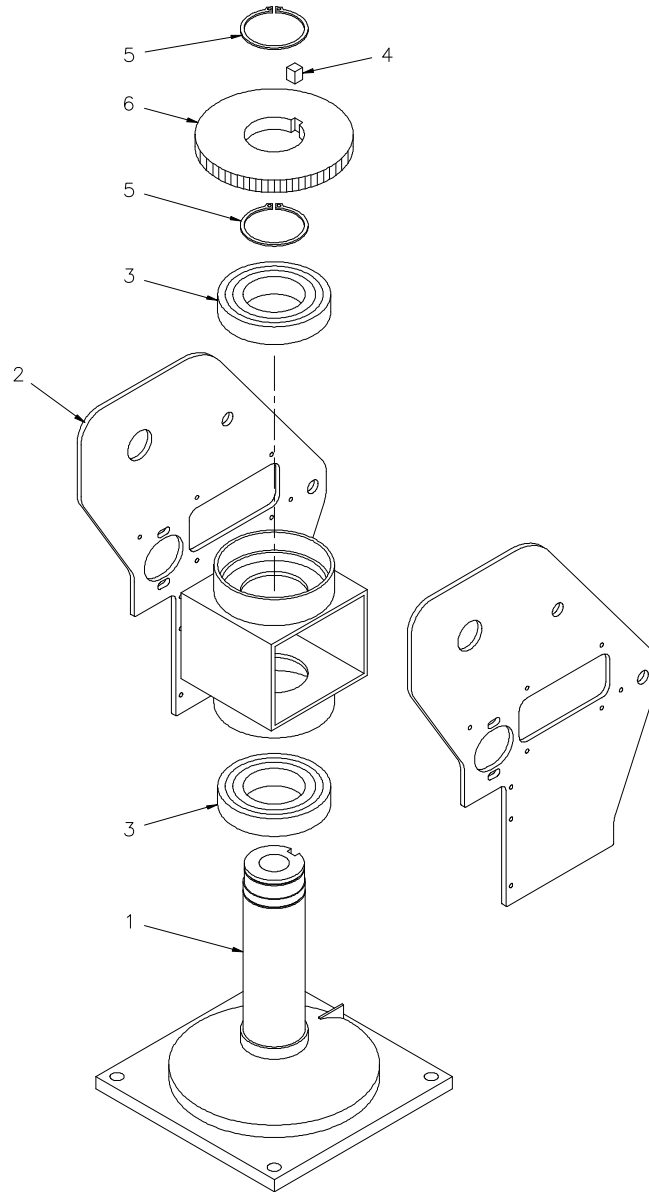

<u>ITEM</u>	<u>QTY</u>	<u>P/N</u>	<u>DESCRIPTION</u>
1	1	404025	PEDESTAL
2	1	404020	SIDE PLATES/QUILL HOUSING
3	2	404017	ROTATION BEARING
4	1	340602	KEY 3/4 SQ x 1
5	2	404028	GEAR RETAINING RING
6	1	404016	WORM GEAR

BOOM ASSEMBLY (8-12-16)

P/N 404010 - MODEL 4004EH

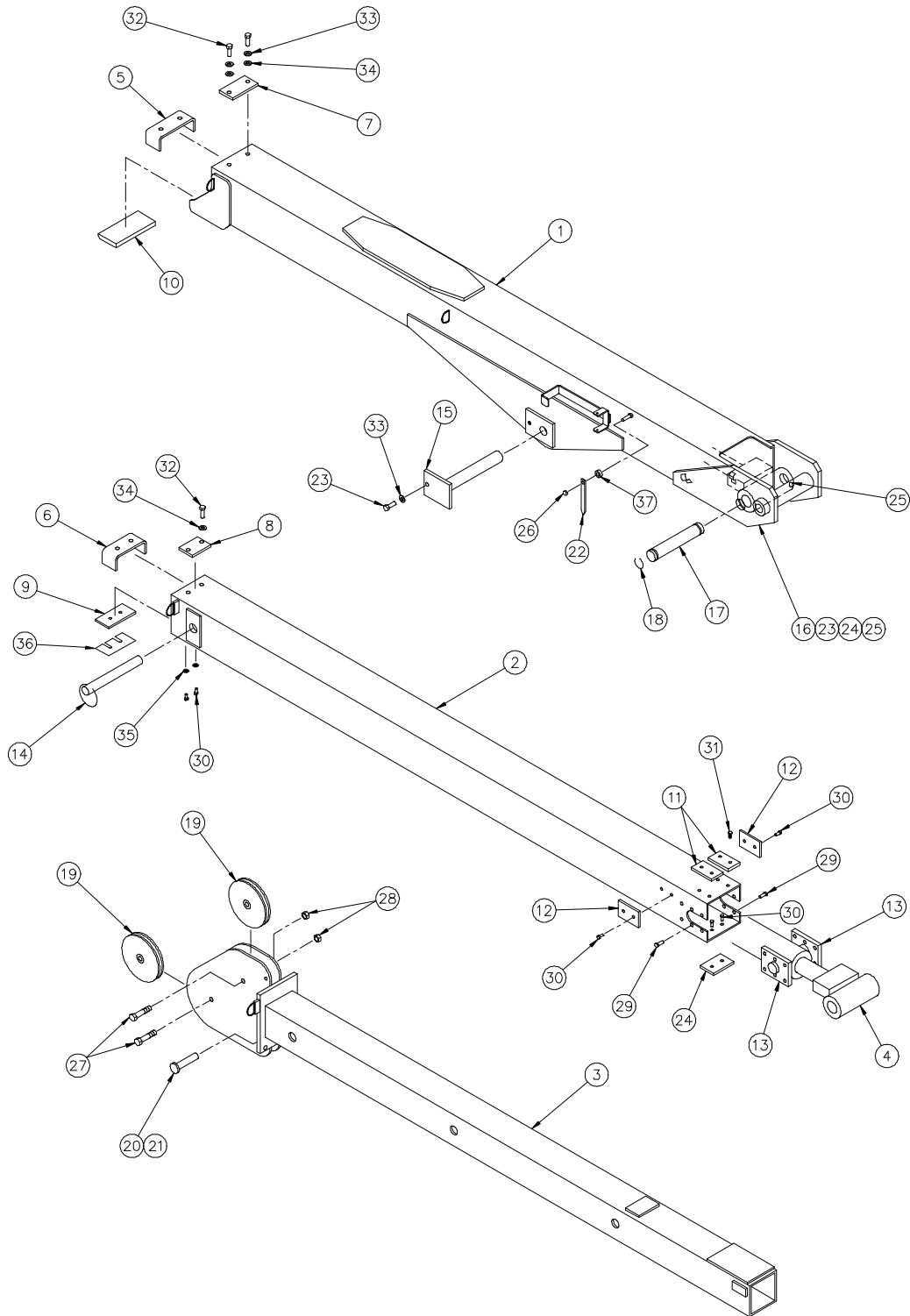

BOOM ASSEMBLY (8-12-16)

P/N 404010 - MODEL 4004EH

<u>ITEM</u>	<u>QTY</u>	<u>P/N</u>	<u>DESCRIPTION</u>
1	1	404030	LOWER BOOM
2	1	404032	CENTER BOOM
3	1	404035	MANUAL BOOM
4	1	404006	BOOM EXTENSION CYLINDER
5	1	366183	CENTER BOOM STOP
6	1	366112	UPPER BOOM STOP
7	1	366201	BOOM TOP PAD
8	1	366202	BOOM TOP PAD
9	1	366199	BOOM PAD
10	1	366187	RETAINER LOWER PAD
11	2	480036	CENTER BOOM TOP PAD
12	3	366186	CENTER BOOM PAD
13	2	366184	EXTENSION CYLINDER RETAINER
14	1	366190	PIN ASSEMBLY w/ LANYARD
15	1	360819	BOOM CYLINDER PIN
*16	1	360625	LOWER BOOM PIVOT PIN
17	1	366193	EXTENSION CYLINDER PIN
18	2	480029	RETAINING RING
19	2	240236	SHEAVE ASSEMBLY
20	1	360814	CROWN PIN
21	1	360124	HITCH PIN
22	1	360038	ANGLE INDICATOR
23	2	366158	CAPSCREW 3/8 NC x 3/4 GR8
*24	1	480120	BOOM PAD
25	1	239000	GREASE ZERK
26	1	016300	LOCK NUT 1/4 NC
27	2	011511	CAPSCREW 1/2 NF x 2 1/4
28	2	017700	LOCK NUT 1/2 NF
29	12	008400	CAPSCREW 3/8 NC x 3/4
30	6	007808	CAPSCREW 5/16 NC x 1/2
31	6	005406	CAPSCREW 1/4 NF x 1/2
32	4	008800	CAPSCREW 3/8 NC x 1
33	6	021100	LOCK WASHER 3/8
34	6	021200	FLAT WASHER 3/8
35	2	020600	LOCK WASHER 5/16
36	A/R	480037	SHIM
37	1	360849	PLASTIC SPACER 1/4 Ø

BOOM ASSEMBLY (8-12)

P/N 404105 - MODEL 4004EH

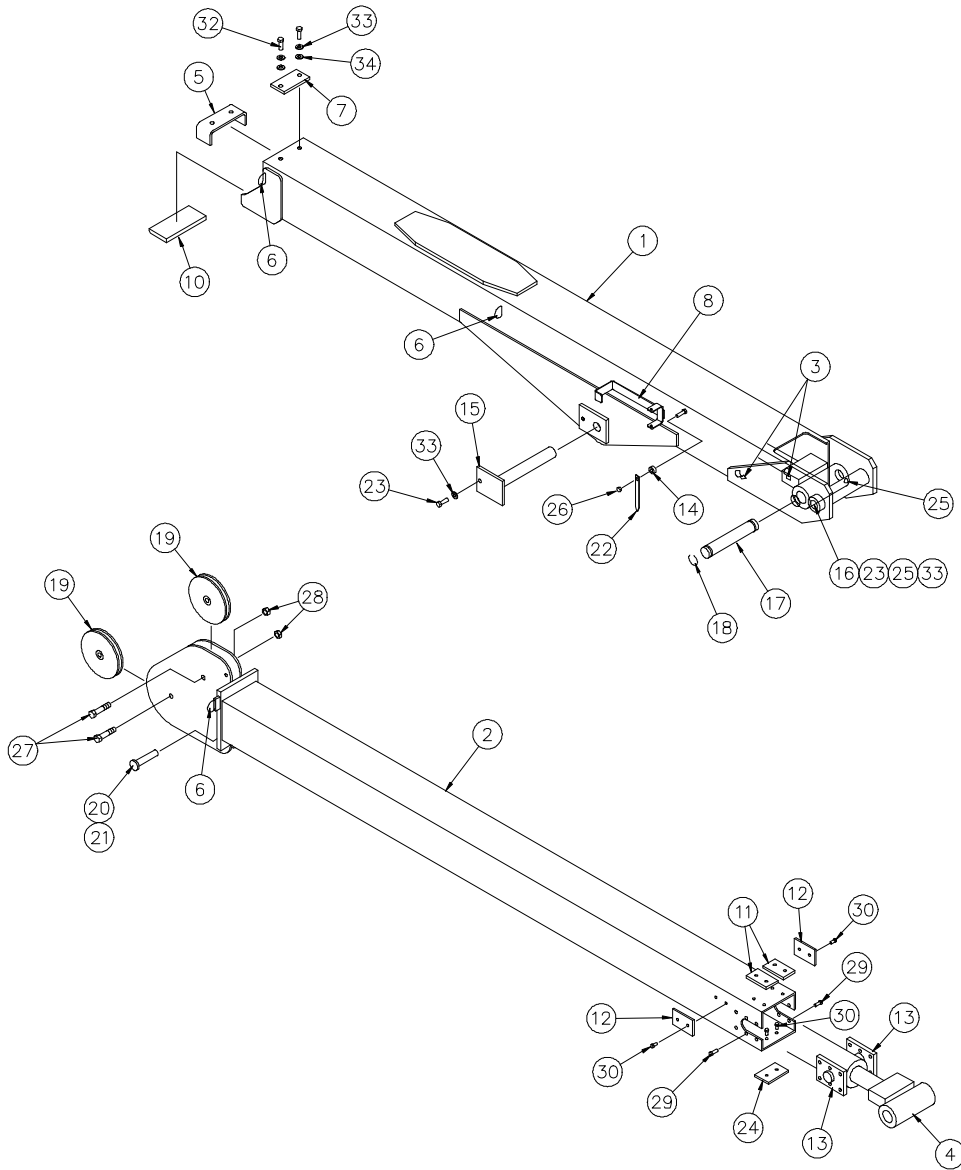

BOOM ASSEMBLY (8-12)

P/N 404105 - MODEL 4004EH

<u>ITEM</u>	<u>QTY</u>	<u>P/N</u>	<u>DESCRIPTION</u>
1	1	404030	LOWER BOOM
2	1	404107	CENTER BOOM
3	2	000115	CLIP <i>(not included)</i>
4	1	404006	BOOM EXTENSION CYLINDER
5	1	366183	CENTER BOOM STOP
6	4	366108	D-RING <i>(not included)</i>
7	1	366201	BOOM TOP PAD
8	1	320551	CORD REEL BRACKET <i>(not included)</i>
9	1	330603	SEAL KIT
10	1	366187	RETAINER LOWER PAD
11	2	480036	CENTER BOOM TOP PAD
12	2	366186	CENTER BOOM PAD
13	2	366184	EXTENSION CYLINDER RETAINER
14	1	360849	PLASTIC SPACER 1/4 Ø
15	1	360819	BOOM CYLINDER PIN
16	1	360625	LOWER BOOM PIVOT PIN
17	1	366193	EXTENSION CYLINDER PIN
18	2	480029	RETAINING RING
19	2	240236	SHEAVE ASSEMBLY
20	1	360814	CROWN PIN
21	1	360124	HITCH PIN
22	1	360038	ANGLE INDICATOR
23	2	366158	CAPSCREW 3/8 NC x 3/4 GR8
24	1	480120	BOOM PAD
25	1	239000	GREASE ZERK
26	1	016300	LOCK NUT 1/4 NC
27	2	011511	CAPSCREW 1/2 NF x 2 1/4
28	2	017700	LOCK NUT 1/2 NF
29	12	008400	CAPSCREW 3/8 NC x 3/4
30	4	007808	CAPSCREW 5/16 NC x 1/2
31	6	005406	CAPSCREW 1/4 NF x 1/2
32	4	008800	CAPSCREW 3/8 NC x 1
33	4	021100	LOCK WASHER 3/8
34	6	021200	FLAT WASHER 3/8

2-BLOCK ASSEMBLY

MODEL 4004EH

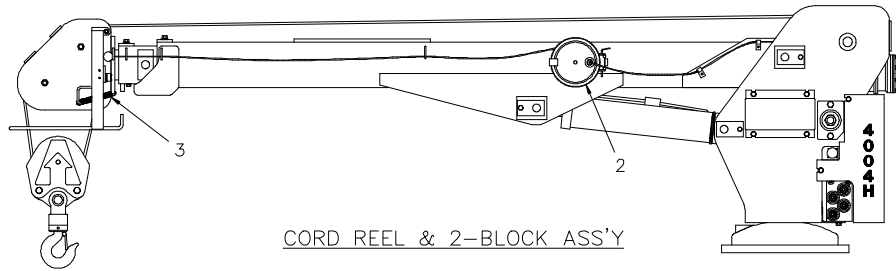

CORD REEL & 2-BLOCK ASS'Y

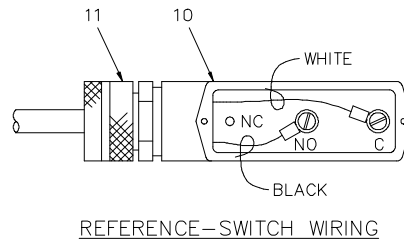

REFERENCE-SWITCH WIRING

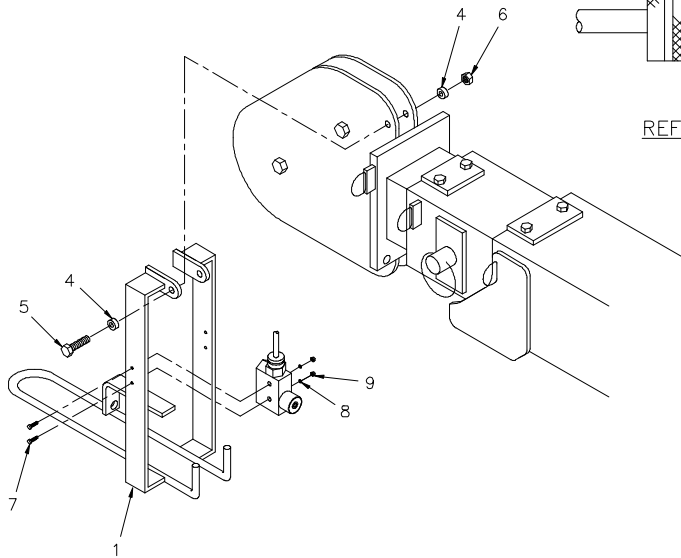

<u>ITEM</u>	<u>QTY</u>	<u>P/N</u>	<u>DESCRIPTION</u>
1	1	360823	2-BLOCK WELDMENT
2	1	366973-001	CORD REEL ASSY w/WEATHER PACK CONNECTORS
3	1	360824	2-BLOCK SPRING
4	2	360852	PLASTIC SPACER 3/8 Ø
5	1	009800	CAPSCREW 3/8 NF x 3 1/2
6	1	017400	LOCK NUT 3/8 NF
7	2	000610	ROUND HEAD SCREW #6 NC x 1 1/2
8	2	019600	LOCK WASHER #6
9	2	015400	NUT #6 NC
10	1	646900	SWITCH
11	1	642908	CORD CONNECTOR

HOIST ACTUATOR

P/N 404007 - MODEL 4004EH

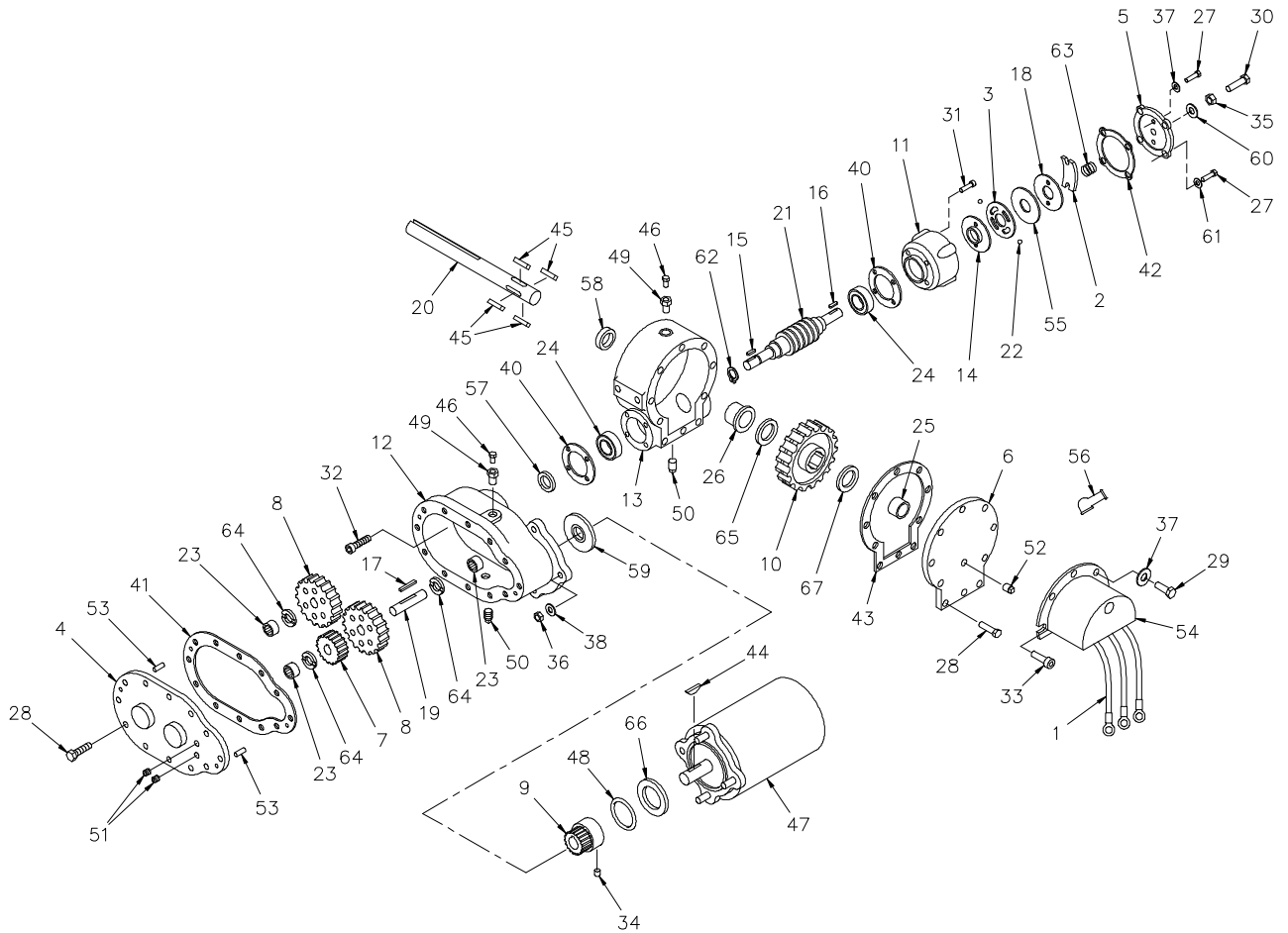

HOIST ACTUATOR

P/N 404007 - MODEL 4004EH

<u>ITEM</u>	<u>QTY</u>	<u>P/N</u>	<u>DESCRIPTION</u>
1	1	360467	SOLENOID ASSEMBLY - 12V
2	1	360367	FLAT SPRING
3	1	360331	CAM PLATE
4	1	300042	SPUR GEAR HOUSING COVER
5	1	360450	BRAKE COVER
6	1	360458	WORM GEAR HOUSING COVER
7	1	300043	IDLER GEAR
8	2	300044	SPUR GEAR
9	1	300046	PINION GEAR
10	1	404078	RH WORM GEAR
11	1	360336	BRAKE HOUSING
12	1	300047	SPUR GEAR HOUSING
13	1	360461	GEAR HOUSING
14	1	360339	BRAKE HOUSING
15	1	300049	SQARE END KEY
16	1	360341	ROUND END KEY
17	1	300050	SQARE END KEY
18	1	360342	RETAINER PLATE
19	1	300053	SPUR SHAFT
20	1	360556	OUTPUT SHAFT
21	1	404079	RH 30:1 WORM
22	2	360345	BALL
23	3	300056	NEEDLE BEARING
24	2	300057	BALL BEARING
25	1	360462	BUSHING COVER
26	1	360348	BUSHING HOUSING
27	6	360453	CAPSCREW 1/4 NC x 1 w/ NYLOC
28	17	005500	CAPSCREW 1/4 NC x 3/4
29	3	005604	CAPSCREW 1/4 NC x 1
30	1	360456	CAPSCREW 3/8 NC x 1 1/2
31	4	360463	SOCKET HEAD SCREW 1/4 NC x 7/8
32	4	320310	SOCKET HEAD SCREW 1/4 NC x 1
33	2	005610	CAPSCREW 1/4 NC x 3/4
34	1	300061	SETSCREW

HOIST ACTUATOR
P/N 404007 - MODEL 4004EH

<u>ITEM</u>	<u>QTY</u>	<u>P/N</u>	<u>DESCRIPTION</u>
35	1	360353	JAM NUT 3/8
36	3	071010	NUT 3/8 NF
37	5	360455	FLAT WASHER 1/4
38	3	021100	LOCKWASHER
39	-	-	-
40	2	300062	GASKET
41	1	300063	GASKET
42	1	360359	GASKET
43	1	360459	GASKET
44	1	360065	WOODRUFF KEY
45	4	360464	BARTH KEY
46	2	300066	RELIEF FITTING
47	1	404077	12V MOTOR
48	1	300068	O-RING
49	2	300069	REDUCER
50	2	360362	SQARE HEAD PIPE PLUG
51	2	320382	SOCKET HEAD PIPE PLUG
52	1	300073	SOCKET HEAD PIPE PLUG
53	2	300075	PIN
54	1	360468	SOLENOID COVER
55	1	360364	THRUST PLATE
56	1	360469	RUBBER BOOT
57	1	300076	OIL SEAL
58	1	300077	OIL SEAL
59	1	300078	OIL SEAL
60	1	360371	THREAD SEAL
61	4	360465	THREAD SEAL
62	1	300079	SNAP RING
63	1	360368	SPRING
64	3	300080	THRUST WASHER
65	1	300081	THRUST WASHER
66	1	300082	FIBER WASHER
67	1	360466	THRUST WASHER

AUTOMATIC SAFETY BRAKE ASSEMBLY (OIL COOLED) HOIST

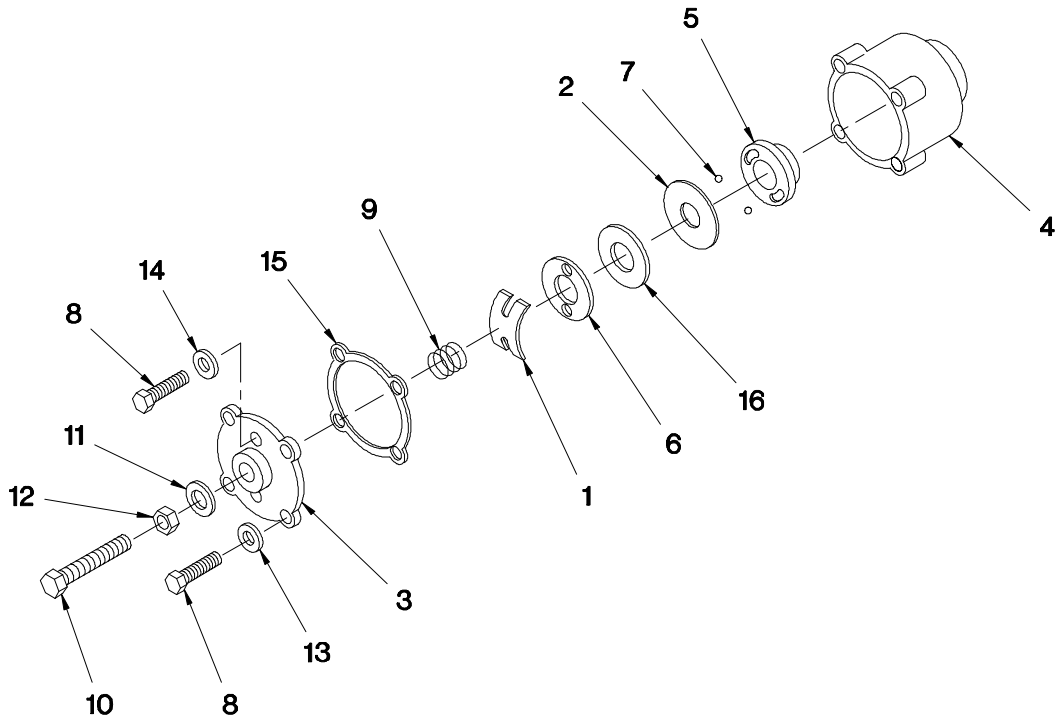

<u>ITEM</u>	<u>QTY</u>	<u>P/N</u>	<u>DESCRIPTION</u>
1	1	360367	FLAT SPRING
2	1	360331	CAM PLATE
3	1	360450	HOUSING COVER
4	1	360336	BRAKE HOUSING
5	1	360339	BRAKE HUB
6	1	360342	RETAINER PLATE
7	2	360345	BRAKE BALL
8	6	360453	CAPSCREW 1/4 NC x 1
9	1	360368	COIL SPRING
10	1	360456	CAPSCREW 3/8 NC x 1 1/2
11	1	360371	THREAD SEAL
12	1	360353	JAM NUT 3/8 NC
13	4	360465	THREAD SEAL
14	2	360455	WASHER FLAT 1/4 ALUM
15	1	360359	GASKET
16	1	360364	THRUST PLATE

AUTOMATIC SAFETY BRAKE ASSEMBLY

(OIL COOLED) HOIST

ASSEMBLY INSTRUCTIONS:

1. Winch has right hand worm and gear. Cable spools over drum. Use number one slots for brake balls(7) in cam plate(2).
2. Install brake hub(5) through brake housing(4) on winch worm with key.
3. Assemble balls(7) in cam plate(2) using hard grease to hold balls in place.
4. Place cam plate(2) on brake hub(5), matching its holes with the balls.
5. Install thrust plate(16).
6. Thread capscrew(10) with jam nut (12) and thread seal (11) through housing cover(3).
7. Place gasket(15) on housing cover(3).
8. Install coil spring(9) on capscrew(10).
9. Install flat spring(1) on capscrew(10).
10. Secure retainer plate(6) and flat spring(1) to housing cover(3) using capscrews(8) and washers(14).
11. Using capscrews(8) and thread seals(13) attach housing cover(3) to brake housing(4).
12. Test brake by shifting winch to UP then DOWN to see if brake is working in proper rotation. If not, remove housing cover(3) and locate brake balls(7) in opposite set of slots of cam plate(2).
13. Adjust to suit by tightening or loosening capscrew(10) on outside of housing cover(3). When proper adjustment is obtained, secure capscrew(10) with jam nut(12).

HYDRAULIC TURNER ASSEMBLY

MODEL 4004EH

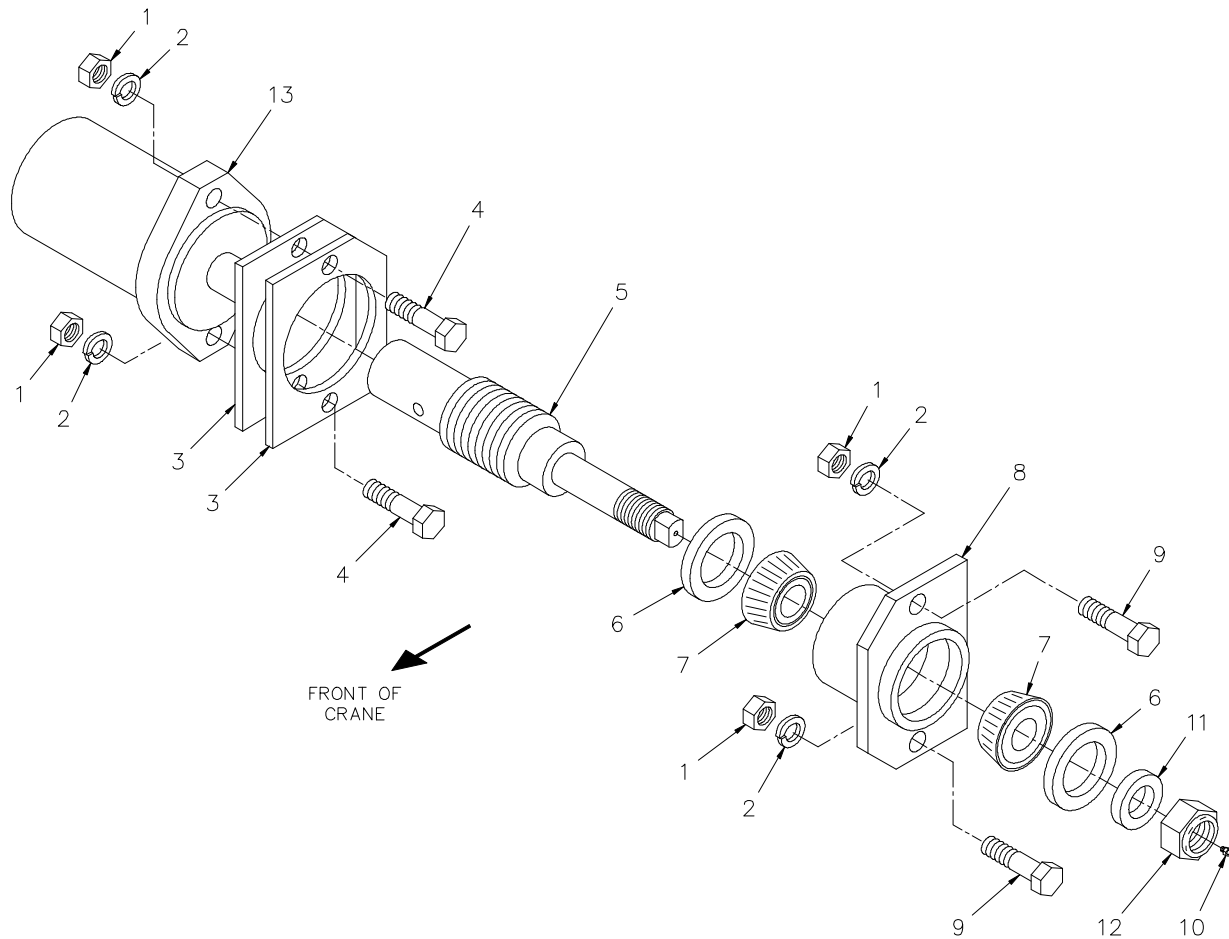

<u>ITEM</u>	<u>QTY</u>	<u>P/N</u>	<u>DESCRIPTION</u>
1	4	017701	NUT 1/2 NC
2	4	021500	LOCK WASHER 1/2
3	2	330484	SPACER
4	2	011603	CAPSCREW 1/2 NC x 1 3/4
5	1	404015	WORM SHAFT ASSEMBLY
6	2	330486	OIL SEAL
7	2	330485	BEARING
8	1	320760	BEARING HOUSING
9	2	010201	CAPSCREW 1/2 NC x 1 1/2
10	1	239300	GREASE ZERK
11	1	330483	SPACER
12	1	019000	LOCK NUT 7/8 NF
13	1	480027	ROTATION MOTOR

TRAVELING BLOCK ASSEMBLY

P/N 360480 - MODEL 4004EH

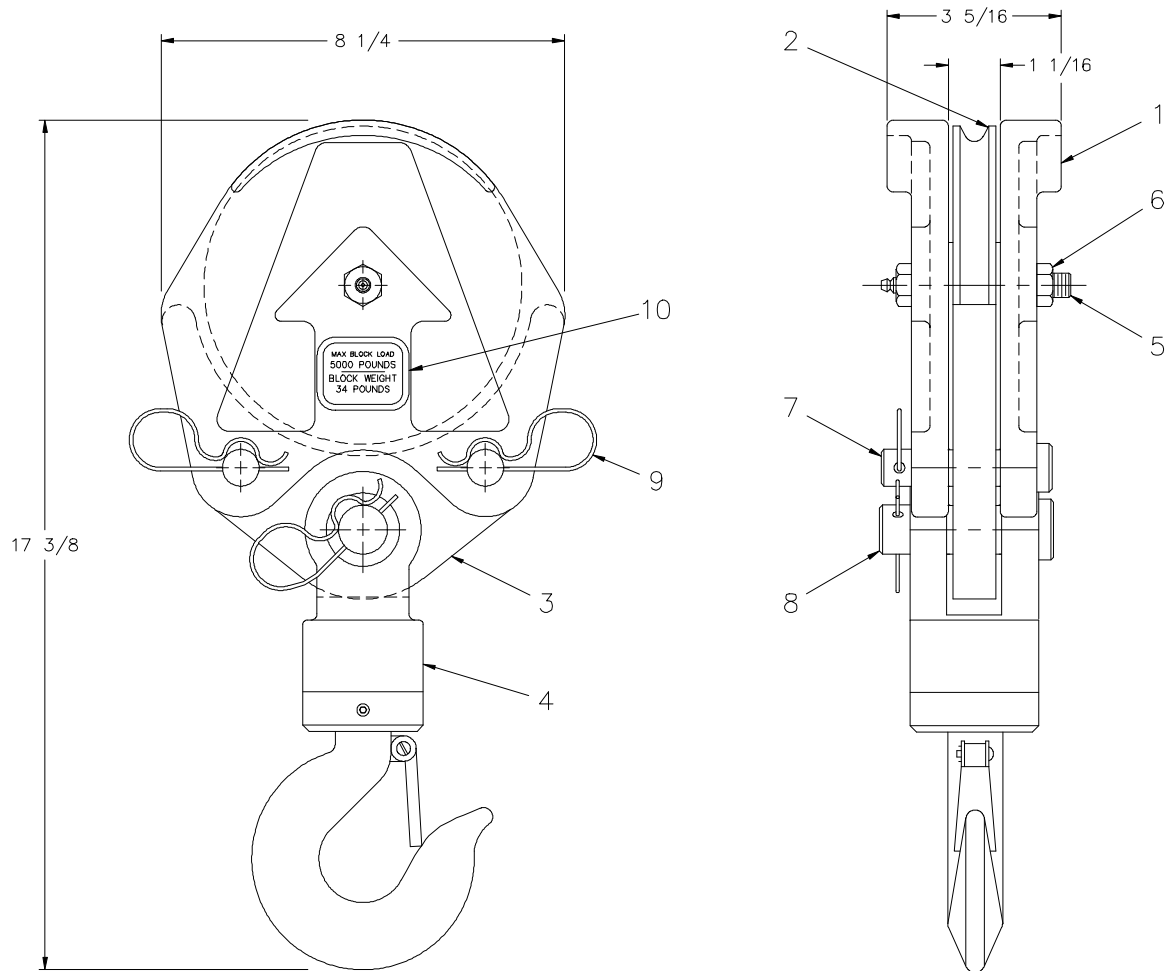

<u>ITEM</u>	<u>QTY</u>	<u>P/N</u>	<u>DESCRIPTION</u>
1	2	480362	SIDE PLATE
2	1	240236	SHEAVE ASSEMBLY
3	1	480364	LOWER TACKLE
4	1	480371	SWIVEL HOOK - 3 TON
5	1	480372	BOLT x 3 1/4 GR8 w/ GREASE ZERK
6	1	017800	LOCK NUT 1/2 NC
7	2	480367	BLOCK PIN
8	1	480368	SWIVEL HOOK PIN
9	3	360124	HITCH PIN
10	2	360480-100	MAXIMUM LOAD DECAL

SOLENOID ASSEMBLY

P/N 360467 - MODEL 4004EH

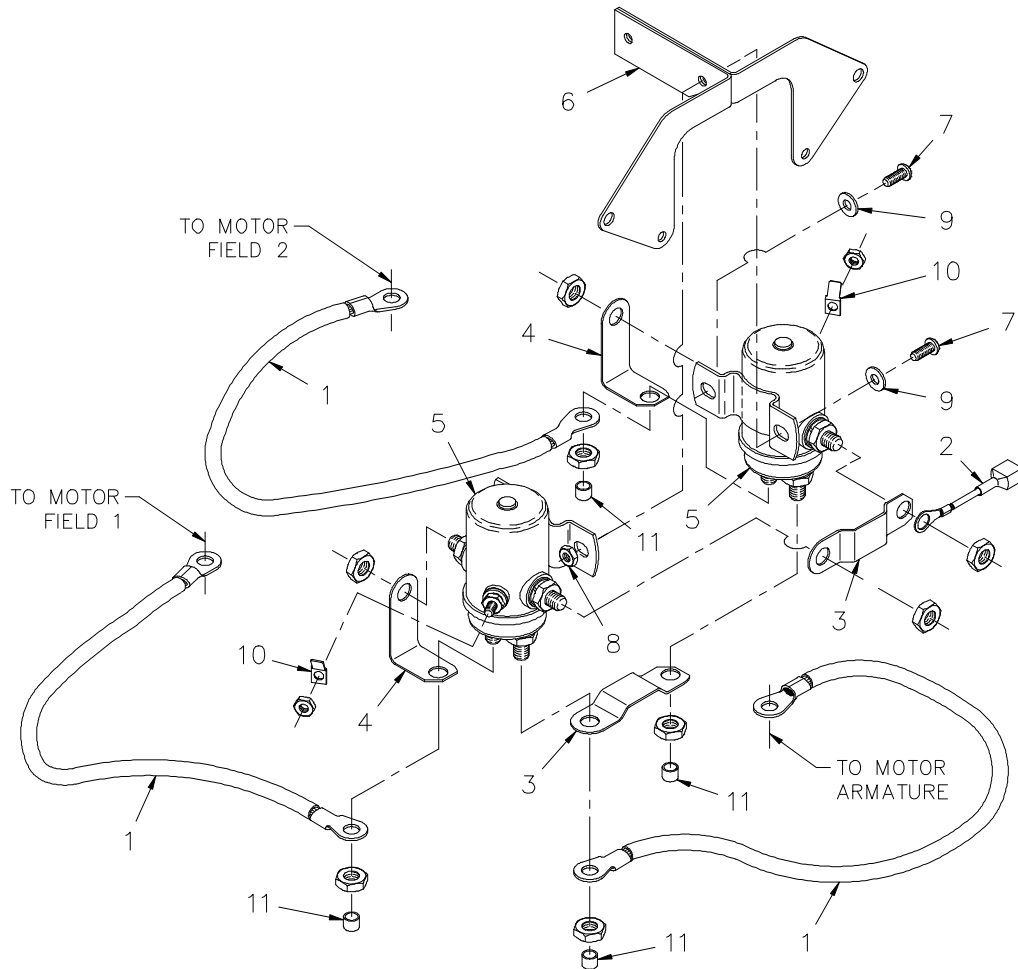

<u>ITEM</u>	<u>QTY</u>	<u>P/N</u>	<u>DESCRIPTION</u>
1	3	360470	BLACK WIRE ASSEMBLY #6 GA x 11 1/2
2	1	360471	RED WIRE ASSEMBLY #16 GA x 1 1/2
3	2	360472	COPPER STRAP
4	2	360473	COPPER STRAP
5	2	200182	12V SOLENOID
6	1	360474	SOLENOID MOUNTING BRACKET
7	2	360475	RD HD SCREW #10 NC x 1/2
8	2	360476	NUT #10 NC
9	2	360477	FLAT WASHER #10
10	2	360478	TERMINAL TAB
11	4	360479	SOLENOID TERMINAL COVER

GENERAL DIMENSIONS

4004EH 8-12-16

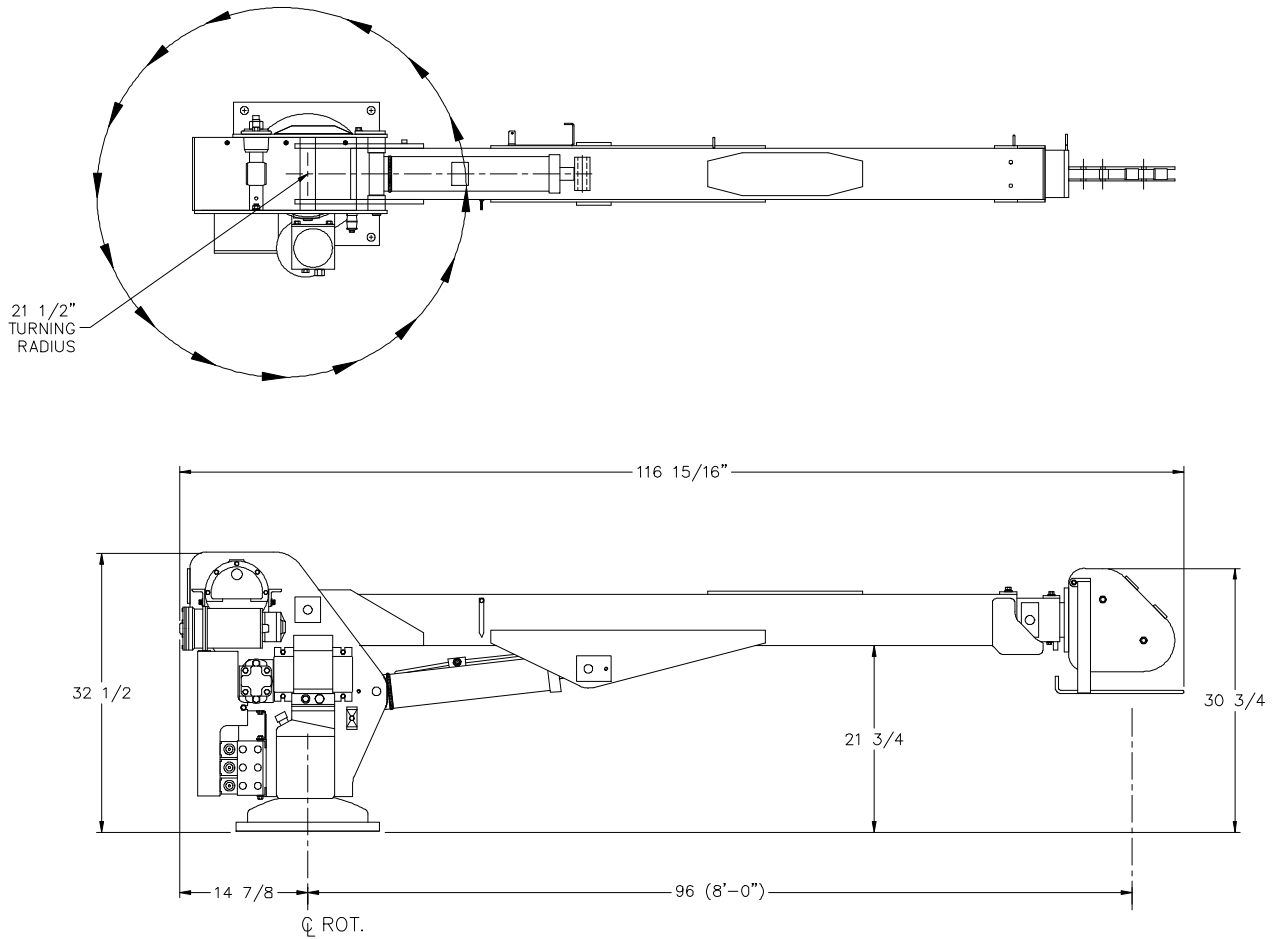

NOTES:

- A. MAX TURNING RADIUS AT ROTATION MOTOR = 13"
- B. MAX TURNING RADIUS AT HOIST ACTUATOR = 20 1/2"

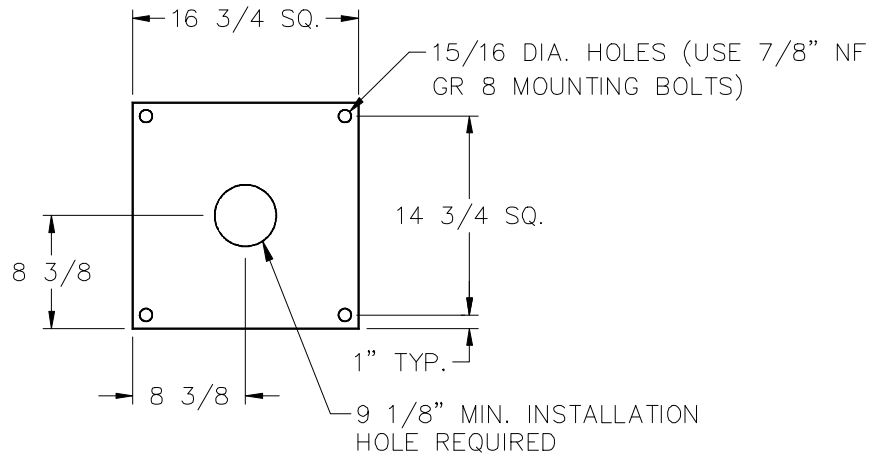

GENERAL DIMENSIONS

4004EH 8-12

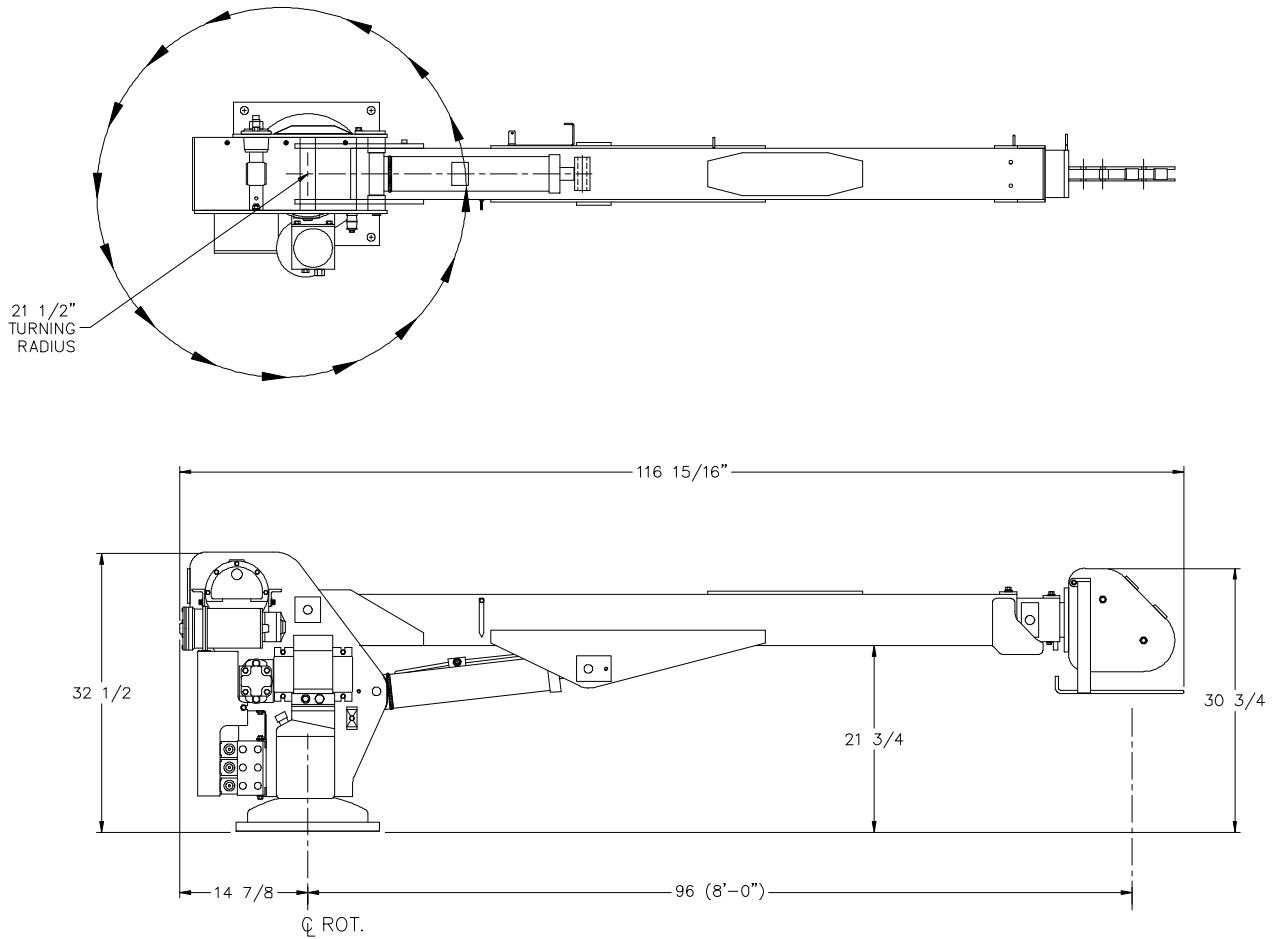

NOTES:

- A. MAX TURNING RADIUS AT ROTATION MOTOR = 13"
- B. MAX TURNING RADIUS AT HOIST ACTUATOR = 20 1/2"

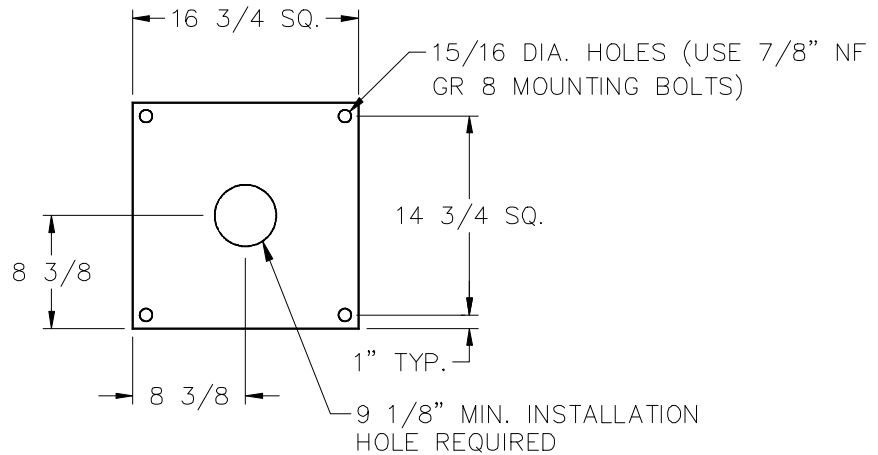

ELECTRICAL ASSEMBLY

P/N 680073 - MODEL 4004EH

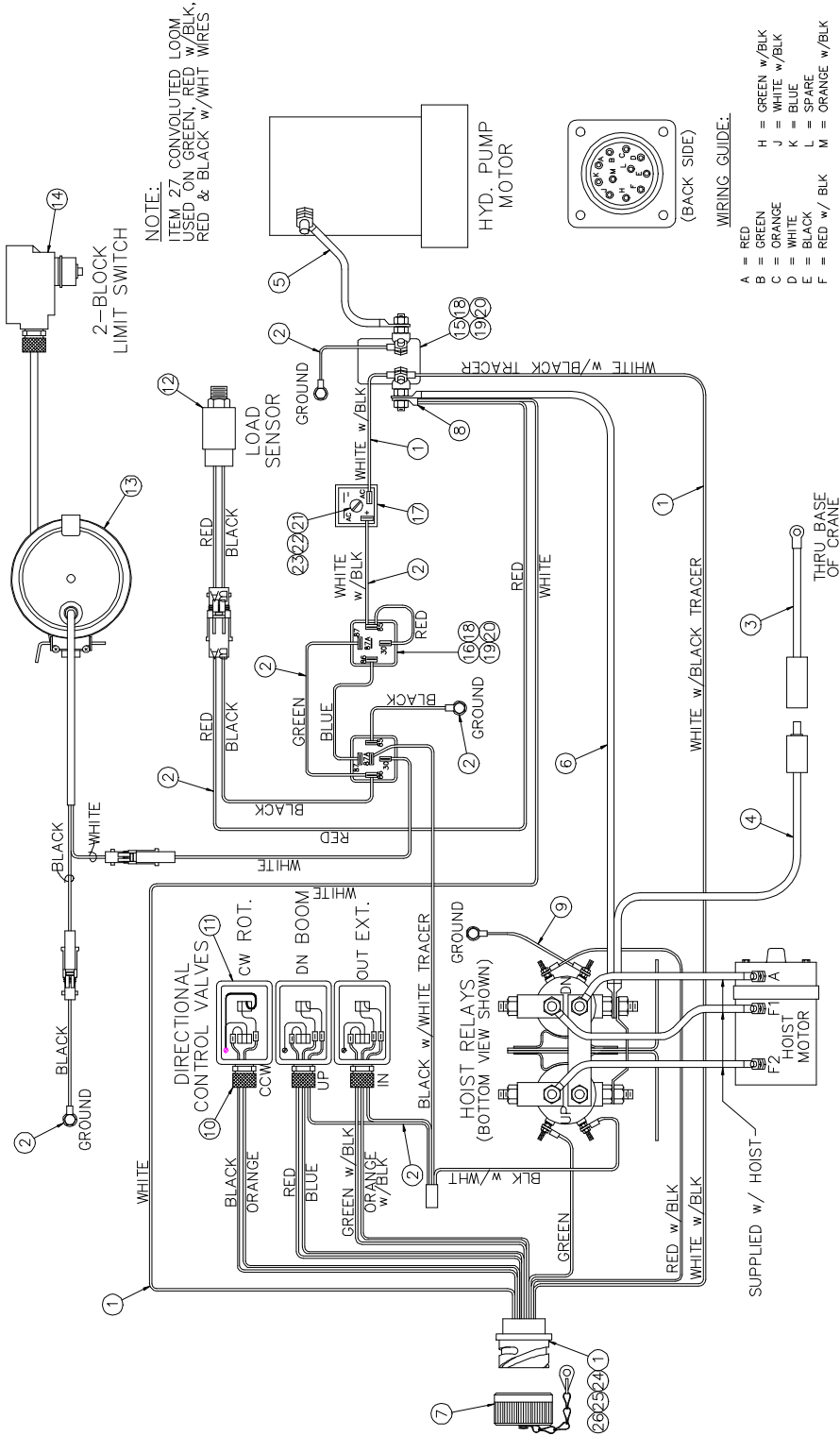

ELECTRICAL ASSEMBLY

P/N 680073 - MODEL 4004EH

<u>ITEM</u>	<u>QTY</u>	<u>P/N</u>	<u>DESCRIPTION</u>
1	1	680074	RECEPTACLE ASSEMBLY
2	1	404061	HARNESS ASSEMBLY
3	1	404056	POWER CABLE ASSEMBLY
4	1	404057	POWER CABLE ASSEMBLY
5	1	622325	CONDUCTOR ASSEMBLY
6	1	622327	CONDUCTOR ASSEMBLY
7	1	320564	CAP W/CHAIN BAYONET
8	1	002005	TERMINAL RING
9	1	360872	CONDUCTOR ASSEMBLY
10	3	642908	CORD CONNECTOR
11	3	300204	DIRECTIONAL CONTROL VALVE
12	1	320543	LOAD SENSOR ASSEMBLY
13	1	360822	2-BLOCK ASSEMBLY
14	1	646900	SWITCH
15	1	200182	12V RELAY
16	2	320355	DROP OUT RELAY
17	1	751138	BRIDGE RECTIFIER 25 AMP
18	4	005604	CAPSCREW 1/4 NC x 1
19	4	015900	NUT 1/4 NC
20	4	020200	LOCK WASHER 1/4
21	1	002502	ROUND HEAD SCREW #10 NF x 1 1/4
22	1	015600	NUT 1/4 NC
23	1	019800	LOCK WASHER #10
24	2	000404	ROUND HEAD SCREW #6 NC x 5/8
25	2	015400	NUT #6 NC
26	2	019600	LOCK WASHER #6
27	2.33'	750736	CONVOLUTED LOOM x 28"

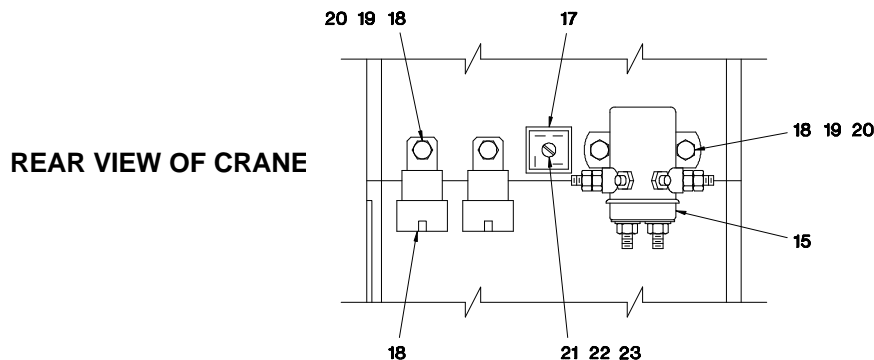

PENDANT ASSEMBLY

P/N 680065 - MODEL 4004EH

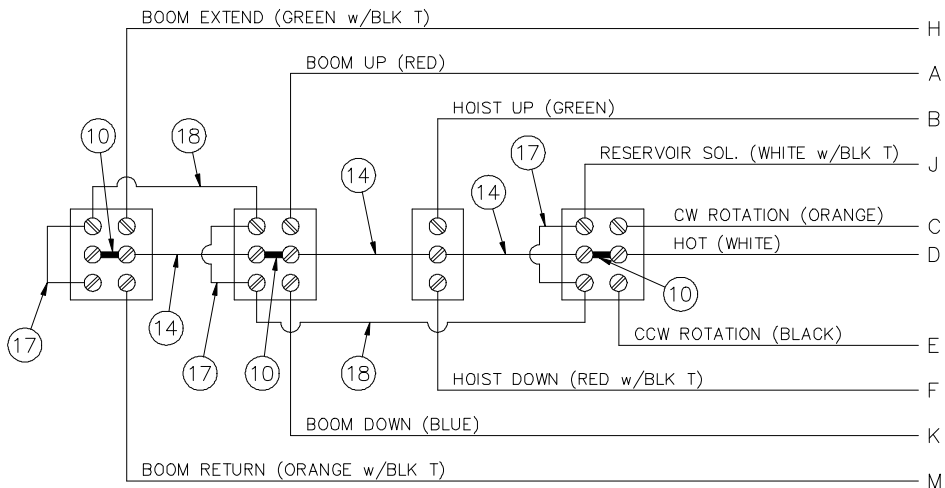
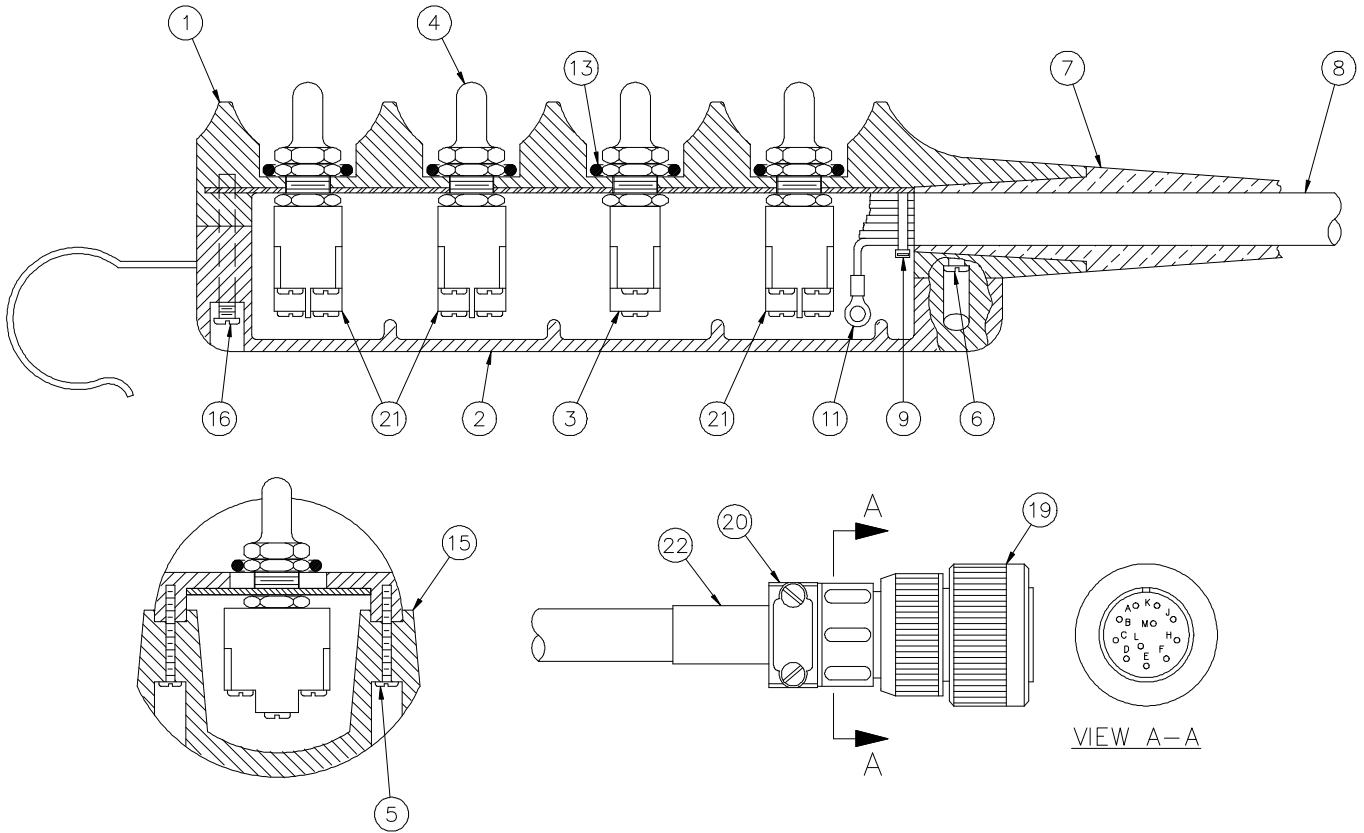

VIEW FROM BOTTOM

PENDANT ASSEMBLY
P/N 680065 - MODEL 4004EH

<u>ITEM</u>	<u>P/N</u>	<u>DESCRIPTION</u>
1	631601	PENDANT HOUSING
2	631700	BOTTOM COVER
3	622000	TOGGLE SWITCH
4	640300	TOGGLE SWITCH BOOT
5	001004	PAN HEAD SCREW #6 x 3/4
6	005101	PAN HEAD SCREW #8 x 1 1/4
7	633801	CABLE ADAPTER
8	800632	CONDUCTOR CABLE X 18'
9	REF	CABLE TIE (634401)
10	636600	JUMPER
11	000101	RING TERMINAL
12	-	-
13	642100	O-RING
14	800592	WIRE 16GA WHITE
15	REF	3/4" OKONITE RUBBER TAPE (800580)
16	004700	PAN HEAD SCREW #8 x 1 1/2
17	622346	CONDUCTOR ASSEMBLY 2 1/8
18	622347	CONDUCTOR ASSEMBLY 3 1/8
19	320563	PLUG 11 PIN BAYONET
20	480515	CABLE CLAMP
21	634200	TOGGLE SWITCH
22	490243	TUBING HEAT SHRINK

RELAY CHECKING PROCEDURE

NOTE:

The following procedure is performed with relays completely disconnected from all wires on motor circuits and ground wires. These circuits can give you false readings sometimes.

HOW TO CHECK RELAY:

Checking a relay on this or any Auto Crane product is done in the same way, but there may be a difference in physical appearance of the relay. Shown below are two types of relays used by Auto Crane. Our relays are normally closed across the bottom posts C & D and normally open across the A & B posts. When activated, they will open across C & D and close across A & B. To activate these relays, use 12V positive (+) and 12V negative (-) wires and place them on posts F & E. You may place 12V+ on post F or E as long as you place

12V- on the remaining post F & E. Using an ohm meter or test light, check across posts A & B. You should get an ohm reading or your test light should be on when you have the relay activated. With the relay still activated, check across posts C & D. You should have no ohm reading or test light at this point with relay activated. At this point, disconnect 12V+ and 12V- from posts F & E. This should let relay return to its normal position. Using your ohm meter or test light again, check the relay across posts A & B. If relay is working correctly, you should have no reading at all. Then check across posts C & D. You should have an ohm reading or test light should be on. If you get the above results, relay is okay. If you get any variation in the above explanation on the relay you are checking, check the relay again. If it still shows a difference, the relay is bad and should be replaced.

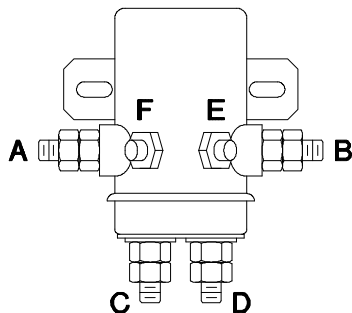
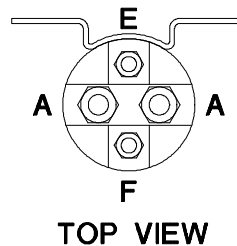

RELAY TYPE A

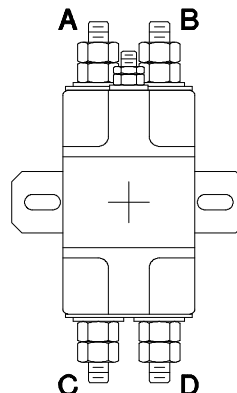

RELAY TYPE B

HYDRAULIC ASSEMBLY

P/N 404003 - MODEL 4004EH

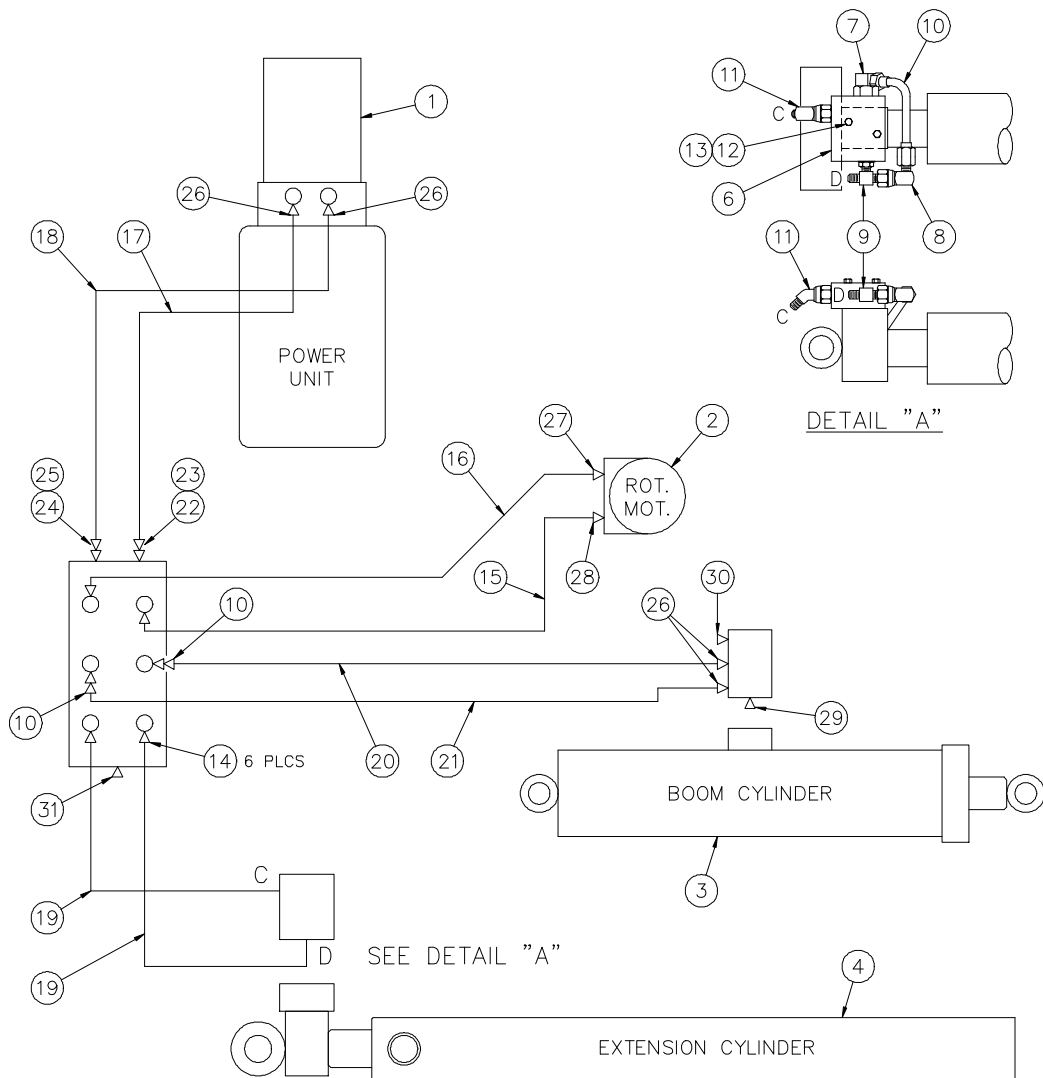

HYDRAULIC ASSEMBLY
P/N 404003 - MODEL 4004EH

<u>ITEM</u>	<u>QTY</u>	<u>P/N</u>	<u>DESCRIPTION</u>
1	1	404008	POWER UNIT
2	1	480027	ROTATION MOTOR
3	1	404005	BOOM UP CYLINDER
4	1	404006	EXTENSION CYLINDER
5	1	202710	MANIFOLD
6	1	330412	COUNTERBALANCE VALVE
7	1	200892	90° ELBOW -6 NPT/-6 JIC
8	1	480194	90° ELBOW -6 JIC SWIVEL/-6 JIC
9	1	241168	TEE -6 ORB/-6 JIC RUN
10	3	480212	TUBE ASSEMBLY
11	1	480195	45° ELBOW -6 ORB/-6 JIC
12	2	005810	CAPSCREW 1/4 NC x 1 3/4
13	2	020200	LOCK WASHER 1/4
14	6	202756	REDUCER -8 ORB/-6 JIC
15	1	404066	TUBE ASSEMBLY
16	1	404067	TUBE ASSEMBLY
17	1	404068	TUBE ASSEMBLY
18	1	404069	TUBE ASSEMBLY
19	2	812203041	HOSE ASSEMBLY
20	1	812212027	HOSE ASSEMBLY
21	1	812215029	HOSE ASSEMBLY
22	1	330058	REDUCER -10 ORB/-6 ORP
23	1	241175	90° ELBOW -6 ORB/-6 JIC
24	1	330274	REDUCER -10 ORB/-8 ORP
25	1	330272	90° ELBOW -8 ORB/-6 JIC
26	4	200876	ADAPTER -6 ORB/ -6 JIC
27	1	320350	45° ELBOW -8 NPTM/-6 JIC
28	1	202759	90° ELBOW -8 ORB/-6 JIC
29	1	480188	COUNTERBALANCE VALVE CARTRIDGE
30	1	320543	LOAD SENSOR ASSEMBLY
31	2	330072	HEX HEAD PLUG -10 ORB

HYDRAULICS

4004EH SERIES

Relief Valve Setting

- { With crane boom supported, remove plug and insert 2500 PSI gauge (see diagram below). Remove boom support and operate boom retract to end of stroke (fully in). Continue operation of the boom in function and read relief pressure on gage. It should read 2200 PSI. If not, readjust system pressure. Leave gauge installed for counterbalance setting procedure.

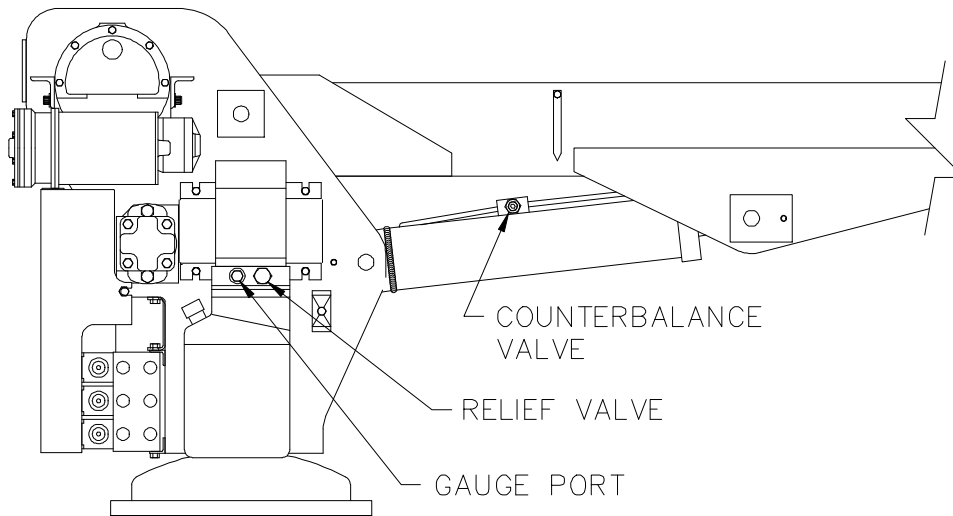

RELIEF & COUNTERBALANCE VALVE ADJUSTMENT

Notice:

If system pressure meets or exceeds the overload pressure switch setting of 2350 PSI, the boom will **LOCK IN THE FULL UP POSITION**. See overload system information in this manual. System pressure well below 2200 PSI will limit the load lifting capabilities of the crane.

Counterbalance Valve Adjustment

- { With no load on boom, boom up to an angle of 60 degrees. Then Boom-Down and note pressure reading. If pressure reading is not approximately 1000 PSI, the counterbalance valve requires adjustment. Repeat boom movement for each test.
- { Loosen nut on adjustment screw and do one of the following:
 - v To increase the counterbalance valve setting, turn the adjustment screw counter clockwise. Located on the front of counterbalance valve block towards end of boom. Loosen nut and adjust Allen head screw.

HYDRAULICS

4004EH SERIES

- v To reduce the counterbalance valve setting, turn the adjustment screw clockwise.
- { Tighten nut on adjustment screw and repeat pressure testing procedure if needed to obtain the proper pressure setting.
- { Support the boom and remove the pressure gauge and reinstall -6 plug. Crane is now ready for operation.

Emergency Lowering Procedure

In an emergency situation when it becomes necessary to lower the boom without flow present, the counterbalance valve adjustment can be turned clockwise until the boom begins to descend. Be careful when turning adjustment! Turning too far will cause valve to NOT operate again!

HYDRAULIC PUMP & RESERVOIR

P/N 404008 - MODEL 4004EH

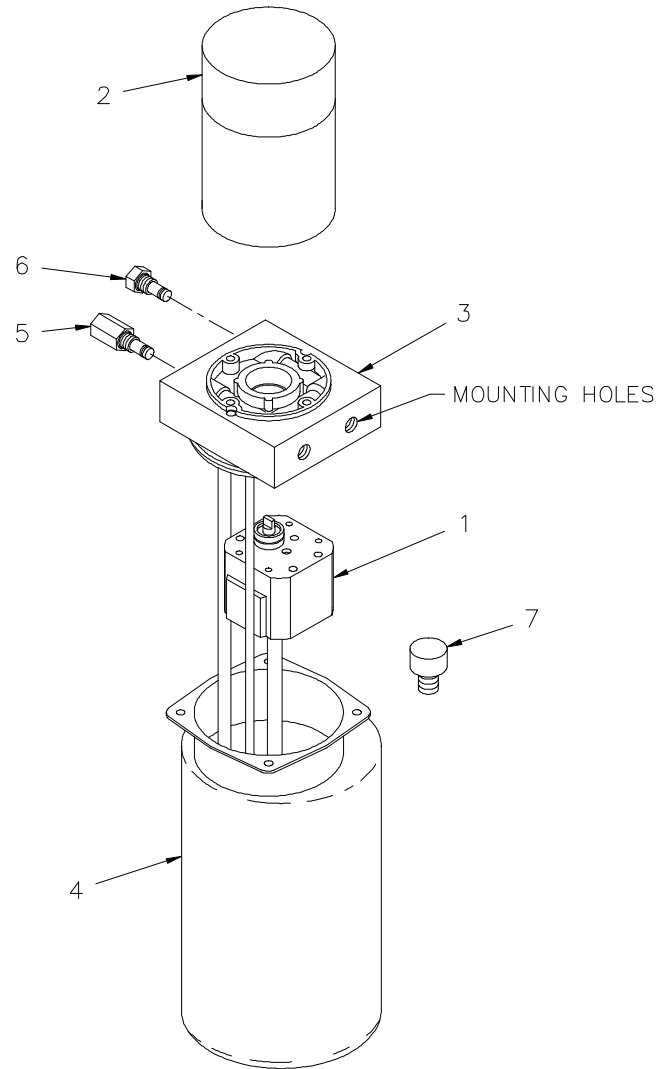

<u>ITEM</u>	<u>QTY</u>	<u>P/N</u>	<u>DESCRIPTION</u>
1	1	404008-001	PUMP KIT
2	1	404008-002	MOTOR
3	1	404008-003	ADAPTER KIT
4	1	404008-004	RESERVOIR KIT
5	1	404008-005	RELIEF VALVE KIT
6	1	404008-006	RETURN PORT PLUG KIT
7	1	404008-007	BREATHER CAP

LOAD CHART 8-12-16

P/N 404050 - 4004EH SERIES

MODEL 4004EH 8-12-16 MAXIMUM LOAD CHART

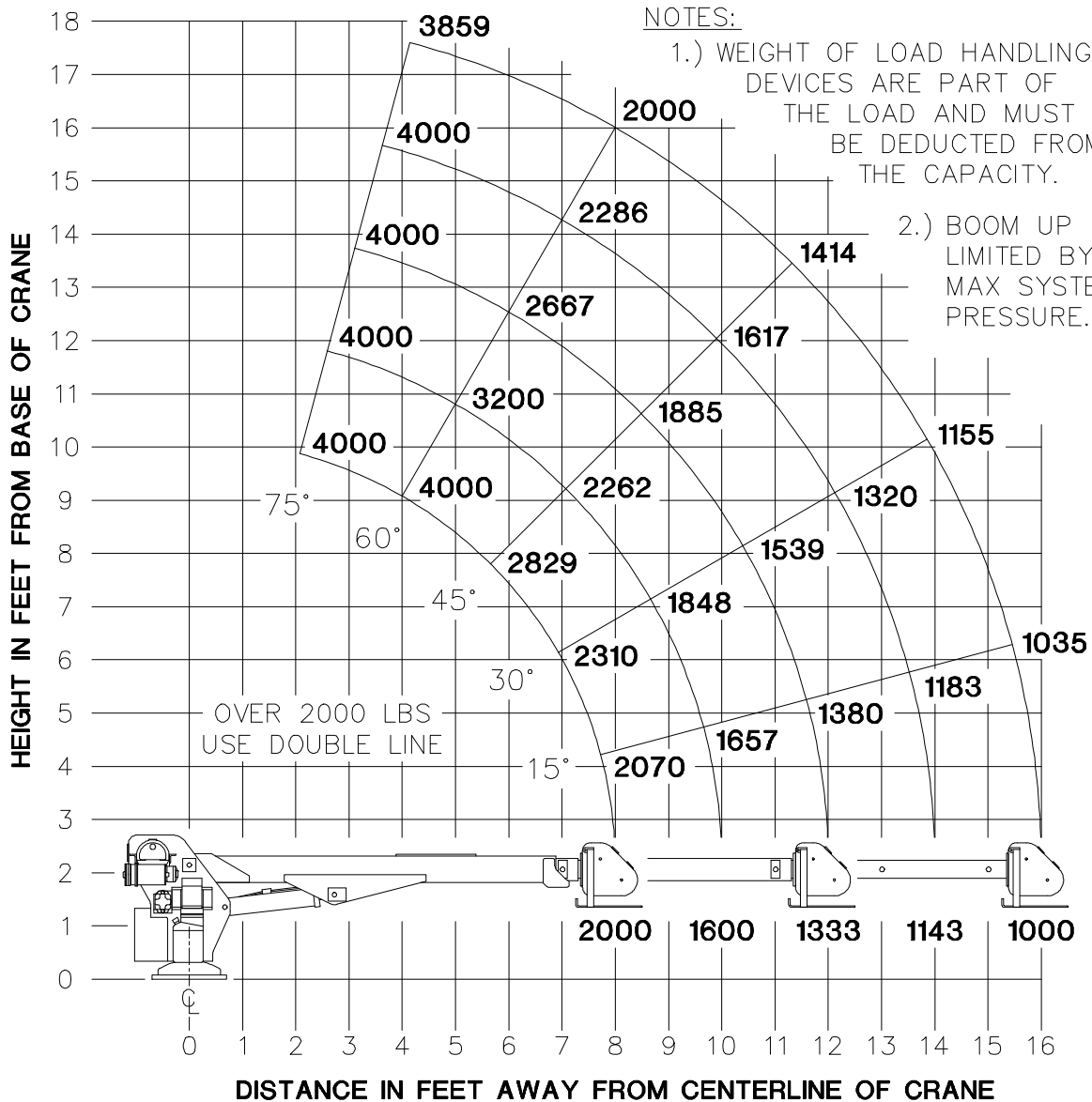

P/N 404050

LOAD CHART 8-12

P/N 404101 - 4004EH SERIES

MODEL 4004EH 8-12 MAXIMUM LOAD CHART

NOTES:

1.) WEIGHT OF LOAD HANDLING DEVICES ARE PART OF THE LOAD AND MUST BE DEDUCTED FROM THE CAPACITY.

2.) BOOM UP LIMITED BY MAX SYSTEM PRESSURE.

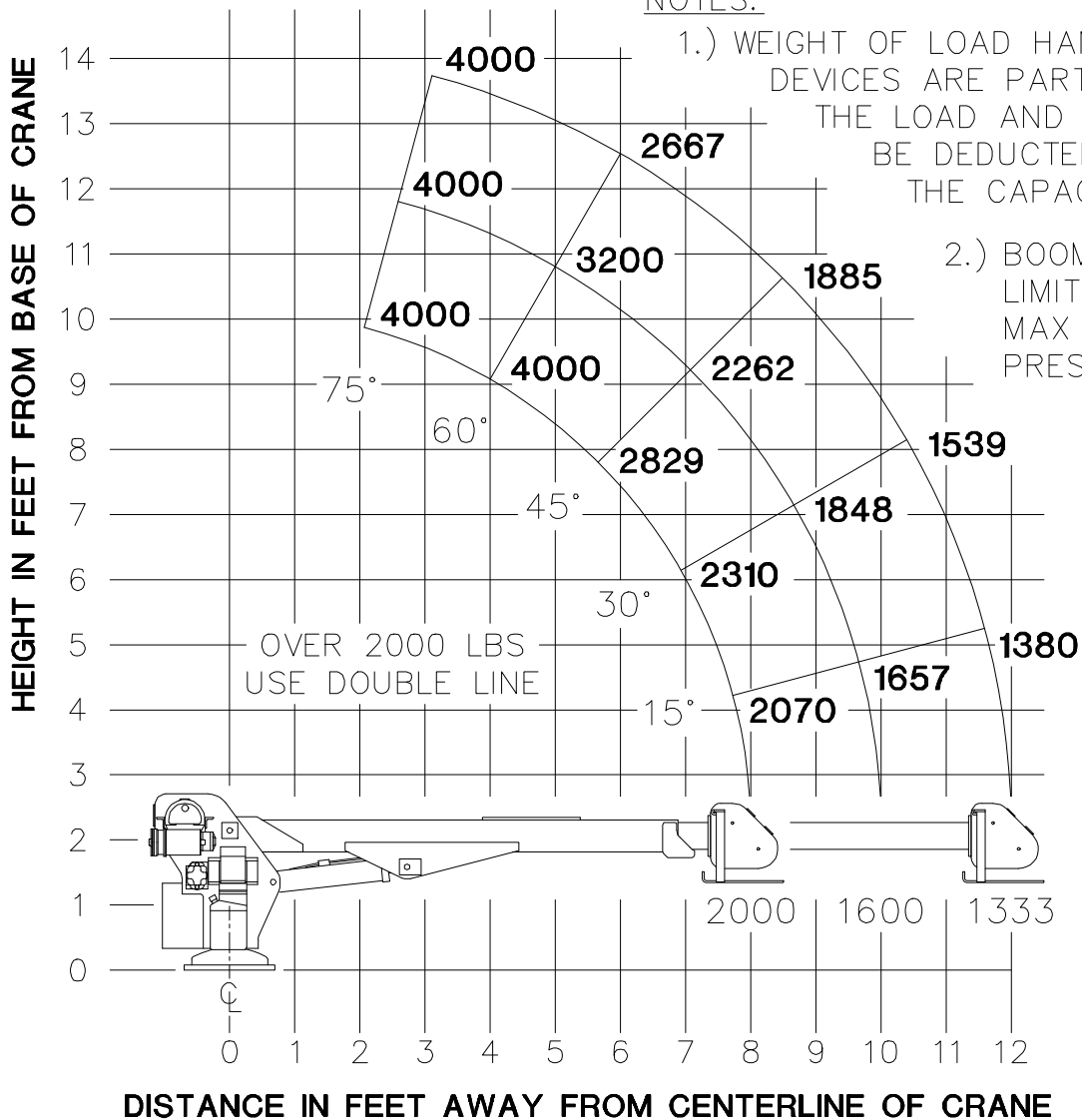

P/N 404101



AUTO CRANE COMPANY

P. O. BOX 581510 • TULSA, OKLAHOMA 74158

Limited Warranty

Auto Crane will warranty to consumer for a period of twelve months from date of purchase that each new Auto Crane product it sells will be free under normal use and service, from defects in material and workmanship. Date of purchase will be honored as either date of purchase by distributor or his date of sale of the product as substantiated by Distributor Delivery Report.

Obligation of Auto Crane under this warranty is limited to replacement or repair of parts that appear to manufacturer after review and / or inspection to be defective. This warranty does not obligate Auto Crane to bear the cost of labor or transportation charges in connection with the replacement or repair of defective parts. Responsibility for customer's claims arising from misapplication, abuse, misuse or alteration of equipment or parts lies with the distributor or user and no warranty obligation is assumed in the circumstances by Auto Crane.

Auto Crane will in no event be liable for any consequential damages or contingent liabilities arising out of the failure of any Auto Crane product or parts to operate properly.

Auto Crane makes no warranty in respect to component accessories, same being subject to the warranties of their respective manufacturers.

If field service, at the request of buyer, is rendered and fault is found not to be with Auto Crane's product, the buyer shall pay the time and expense of the field representative. Claims for service labor or other expenses that have been incurred by the buyer without approval or authorization of Auto Crane will not be accepted.

AUTO CRANE COMPANY IS UNDER NO OBLIGATION TO EXTEND THIS WARRANTY TO ANY CUSTOMER FOR WHICH AN AUTO CRANE WARRANTY REGISTRATION CARD HAS NOT BEEN COMPLETED AND MAILED TO AUTO CRANE COMPANY WITHIN FIFTEEN (15) DAYS AFTER DATE OF PURCHASE.