

EFFECTIVE SERIAL NO. 193-CH-988

OWNERS MANUAL

6006 SERIES

REVISION 6/2000

PART NO. 999934

SERIAL NO. _____

AUTO CRANE COMPANY

PO BOX 580697, TULSA, OK 74158-0697

4707 N. MINGO ROAD, TULSA, OK 74117

PHONE (918) 836-0463

FAX (918) 834-5979

www.autocrane.com

!! DISTRIBUTORS !!

**PROTECT YOUR CUSTOMER'S WARRANTY!
SUBMIT DELIVERY REPORT WITHIN 15 DAYS.**

Mail to: Auto Crane Company
P.O. Box 580697
Tulsa, OK 74158-0697

Or Fax to: 918/834-5979

Protect your customers warranty - Submit within 15 days from delivery date.



AUTO CRANE COMPANY

**DISTRIBUTOR
DELIVERY REPORT**

DISTRIBUTOR _____		OWNER _____	
ADDRESS _____		CITY/STATE _____	
CITY/STATE/ZIP _____		BUSINESS _____	
MODEL #	SERIAL #	DATE DELIVERED	UNIT DESTINATION

IMPORTANT: ATTACH SIGNED COPY OF CUSTOMER INVOICE / DELIVERY RECEIPT

AC-109 REPORT AUTHORIZED BY: _____

*** REGISTER ONE UNIT ONLY PER CARD ***

WARNINGS - READ THIS PAGE!

- { **WARNING!** Federal law (49 cfr part 571) requires that the Final Stage Manufacturer of a vehicle certify that the vehicle complies with all applicable federal regulations. Any modifications performed on the vehicle prior to the final stage are also considered intermediate stage manufacturing and must be certified as to compliance. The installer of this crane and body is considered one of the manufacturers of the vehicle. As such a manufacturer, the installer is responsible for compliance with all applicable federal and state regulations, and is required to certify that the vehicle is in compliance.

- { **WARNING!** It is the further responsibility of the installer to comply with the OSHA Truck Crane Stability Requirements as specified by 29 CFR part 1910.180 (C) (1).

- { **WARNING! NEVER OPERATE THE CRANE NEAR ELECTRICAL POWER LINES!** Death or serious injury will result from boom, line, or load contacting electric lines. Do not use crane within 10 feet (3.05m) of electric power lines carrying up to 50,000 volts. One foot additional clearance is required for every additional 30,000 volts or less.

- { **WARNING! NEVER**
 - v **EXCEED** load chart capacities (centerline of rotation to hoist hook).
 - v un-reel last 5 wraps of cable from drum!
 - v wrap cable around load!
 - v attempt to lift or drag a load from the side! The boom can fail far below its rated capacity.
 - v weld, modify, or use unauthorized components on any Auto Crane unit! This will void any warranty or liability. Also failure of the crane may result.
 - v place a chain link on the tip of the hook and try to lift a load!
 - v use a sling bar or anything larger than the hook throat that could prevent the hook latch from closing, thus negating the safety feature!
 - v hold on any pendant Select Switch that will cause unsafe operating conditions!

- { **WARNING!** In using a hook with latch, **ALWAYS** make sure that the hook throat is closed before lifting a load! Proper attention and common sense applied to the use of the hoist hook and various slings will prevent possible damage to material being hoisted and may prevent injury to personnel.

- { **WARNING!** Failure to correctly plumb and wire crane can cause inadvertent operation and damage to crane and/or personnel!

- { **WARNING!** Auto Crane Company remote controlled cranes are not designed or intended to be used for any applications involving the lifting or moving of personnel.

- { **WARNING! ALWAYS** operate the crane in compliance with the load capacity chart. **Do not use** the overload shutdown device to determine maximum rated loads, if your crane is equipped with this type of device.



6006 SERIES - OWNER'S MANUAL
TABLE OF CONTENTS



INTRODUCTION	1-1.0.0
OPERATING PRACTICES & WARNINGS	1-2.0.0
OPERATION OF UNIT / OUTRIGGERS	1-3.0.0
QUALIFICATIONS FOR OPERATORS	1-4.0.0
INSPECTION, TESTING & MAINTENANCE	1-5.0.0
MOUNTING AND INSTALLATION	2-1.0.0
SAFETY DECAL SECTION	2-3.0.0
GENERAL DIMENSIONS	2-4.0.0
LIFE OF WIRE LINE	3-4.0.0
LUBRICATION & MAINTENANCE SCHEDULE	3-5.0.0
TROUBLESHOOTING	3-6.0.0
GENERAL ASSEMBLY (PEDESTAL)	4-1.0.0
BOOM ASSEMBLY	4-5.0.0
TRAVELING BLOCK ASSEMBLY	4-6.0.0
BRAKE ASSEMBLY	4-7.0.0
HOIST ACTUATOR	4-9.1.0
ELECTRICAL SECTION	5-2.0.0
HYDRAULIC SECTION	6-1.0.0
MISCELLANEOUS	8-1.0.0
LOAD CHART	9-9.9.9
WARRANTY	LAST PAGE

INTRODUCTION

6006 SERIES

Auto Crane products are designed to provide many years of safe, trouble-free, dependable service when properly used and maintained.

To assist you in obtaining the best service from your crane and to avoid untimely crane and/or vehicle failure, this manual provides the following operating and service instructions. It is **specifically recommended** that all operating and service personnel consider this manual as mandatory material for reading and study before operating or servicing Auto Crane products. It is **highly recommended** that crane owners, equipment managers and supervisors also read this manual.

Auto Crane has incorporated several safety features in the 6006 series cranes for your protection. The material and electrical systems were designed to minimize weight and lengthen durability.

For your convenience the overall dimensions of the 6006 series crane are included on the General Dimension Drawing. Rotation and turning radius are also listed on that drawing.

Remember, the crane adds weight to the vehicle. Adding weight may change the driving and riding characteristics of the vehicle unless the appropriate overload spring(s) are installed on the truck. The payload of the vehicle is reduced by the weight of the crane. The operator should exercise care when loading the vehicle. Distributing the payload on the vehicle evenly will greatly improve the driving and riding characteristics of the vehicle.

Auto Crane Company issues a limited warranty certificate with each unit sold. See last page for warranty policy.

The 6006 series cranes are attached directly to your 12 volt truck electrical system. The power cable and retaining clips are included with the crane. A typical power cable mounting and hookup is shown. The 6006 series is another highly efficient Auto Crane product. The use of our "B" actuator maximizes your work capability for the least amperage draw from your truck battery. The performance of your new crane depends on the truck electrical system. The use of the low maintenance battery is not recommended for use on any Auto Crane product. The recommended alternator and battery that will give the longest life with the most useful duty cycle is a 75 amp. alternator with a 500 cold cranking rated battery. These specifications should be considered minimum.

It has always been Auto Crane Company policy to handle all warranty claims we receive as promptly as possible. If a warranty claim involves discrepant material or workmanship, Auto Crane will take immediate corrective action. It is understandable that Auto Crane Company cannot assume responsibility of liability when it is obvious that our products have been abused, misused, overloaded or otherwise damaged by inexperienced persons trying to operate the equipment without reading the manual.

Auto Crane will not assume responsibility or liability for any modifications or changes made to unit, or installation of component parts done without authorization.

Auto Crane maintains a strong distributor network and a knowledgeable Customer Service Department. In most cases, an equipment problem is solved via phone conversation with our customer service department. The customer service department also has the ability to bring a local distributor, a regional sales manager, or a factory serviceman into the solution of an equipment problem. If, through no fault of Auto Crane Company, it is necessary to send an experienced factory serviceman on a field service call, the rates stated in the Auto Crane Distributor's Flat Rate Manual will apply.

Auto Crane Company's extensive Research and Development Program allow our customers to use the best equipment on the market. Our Engineering Staff and our knowledgeable sales people, are always available to our customers in solving crane and winch-type application problems. When in doubt, call the Auto Crane factory.

DISTRIBUTOR ASSISTANCE:

Should you require any assistance not given in this manual, we recommend that you consult your nearest Auto Crane Distributor. Our distributors sell authorized parts and have service departments that can solve almost any needed repair.

NOTE: THIS MANUAL SHOULD REMAIN WITH THE CRANE AT ALL TIMES.

This manual does not cover all maintenance, operating, or repair instructions pertinent to all possible situations. If you require additional information, please contact the **Auto Crane** Company at the following telephone number: **(918) 836-0463**. The information contained in the manual is in effect at the time of this

--- IMPORTANT ---

OPERATING PRACTICES & WARNINGS

1. Make certain the vehicle meets minimum chassis requirements. (These requirements do not guarantee unit stability)
2. Make certain the crane is installed per factory specifications. Contact your local Distributor or the Auto Crane factory if any questions arise.
3. Keep the vehicle in as level a position as possible while loading or unloading.
4. **ALWAYS** set the vehicle emergency brake before beginning crane operations.
5. **ALWAYS** use outriggers from vehicle to the ground during crane operation. Make sure they are firmly positioned on solid footings.
6. All load ratings are based on crane capacity, **NOT** truck/crane stability.
7. Keep objects and personnel clear of crane path during operation.
8. Keep hoist cable pulled tight at all times.
9. **REMEMBER**, in lifting a heavy load, the weight can create enough tipping momentum to overturn the vehicle.
10. **ALWAYS** keep load as close to ground as possible.
11. Oil gears as required.
12. Periodic adjustment of hoist worm brake may be required (see automatic safety brake drawing in this manual).
13. Hydraulic hoses need to be inspected frequently for signs of deterioration, and be replaced as required.
14. The hoist hook is an important item that an operator should consider and use properly. It should be checked on a daily basis for distortion or cracks.
15. **ALWAYS** store outriggers before road travel.
16. **WARNING! NEVER OPERATE THE CRANE NEAR ELECTRICAL POWER LINES!** Death or serious injury will result from boom, line, or load contacting electric lines. Do not use crane within 10 feet (3.05m) of electric power lines carrying up to 50,000 volts. One foot additional clearance is required for every additional 30,000 volts or less.
17. **WARNING! NEVER EXCEED** load chart capacities (centerline of rotation to hoist hook).
18. **WARNING! NEVER** un-reel last 5 wraps of cable from drum!
19. **WARNING! NEVER** wrap cable around load!
20. **WARNING! NEVER** attempt to lift or drag a load from the side! The boom can fail far below its rated capacity.
21. **WARNING! NEVER** weld, modify, or use unauthorized components on any Auto Crane unit! This will void any warranty or liability. Also failure of the crane may result.
22. **WARNING! NEVER** place a chain link on the tip of the hook and try to lift a load!
23. **WARNING! NEVER** use a sling bar or anything larger than the hook throat that could prevent the hook latch from closing, thus negating the safety feature!
24. **WARNING!** In using a hook with latch, **ALWAYS** insure that the hook throat is closed before lifting a load! Proper attention and common sense applied to the use of the hoist hook and various slings will prevent possible damage to material being hoisted and may prevent injury to personnel.
25. **WARNING! NEVER** hold any pendant Select Switch on that will cause unsafe operating conditions!

WARNING!

Auto Crane Company remote controlled, stiff boom cranes are not designed or intended to be used for any applications involving the lifting or moving of personnel.

--- IMPORTANT --- OPERATION OF UNIT

26. Make sure this manual has been thoroughly read by all crane operating personnel and supervisors.
27. A routine inspection of the crane should be mandatory before each operating day. Any defects should be corrected immediately.
28. At a job site the vehicle should be positioned so that the crane can adequately reach the load within the rated capacity (centerline of rotation to hoist hook).
29. Keep the vehicle as level as possible during operation.
30. For electric cranes, **engage emergency brake** and leave ignition on with transmission in neutral (or in park for automatic transmissions). Activate any crane power switches. For Auto Crane units requiring battery and hydraulic operation, **engage emergency brake**, place gear selector in neutral, press clutch, activate PTO, release clutch and after hydraulic fluid is warm, set throttle control to proper engine speed.
31. Always use outriggers from the truck to the ground. Be sure these are firm and adequately positioned. When rotating, **keep load as low to the ground as possible**.
32. Remove pendant control from cab or storage area. On smaller units, plug pendant into receptacle on crane. On larger units, remove pendant control from guard and unwrap cable from boom. Do not operate crane until cable is unwound completely. On all cranes, detach hook from dead man. Crane is now ready for operation.
33. Always boom up before rotating so the boom will clear the required boom support.
34. When extending the boom, always maintain clearance between the boom crown and the traveling block or hoist hook.
35. Always observe safe and practical operation to avoid possible accidents. Refer to Safety Tips and Precautions.
36. After completing lifting operations, return the boom to stowed position on the boom support. Avoid unneeded pressure on the boom support.
37. Store pendant control on proper location (in cab or on crane).
38. Return outriggers to stowed position. Make sure they are pinned in place or jacklegs are returned to compartment.
39. Check work area for any tools or equipment not stored.
40. Release throttle control, depress clutch and disengage PTO. Deactivate any crane power switches.
41. Report any unusual occurrence during crane operation that may indicate required maintenance or repair.
42. **NEVER** use two cranes to support a load too large for either crane.
43. Spray all electrical equipment with special corrosion resistant coating. This eliminates rust or corrosion due to melting and freezing action of condensation.

OPERATION OF OUTRIGGERS

For hydraulic outriggers:

1. Shift crane/outrigger control valve to "outrigger" position.
2. While operating the outrigger control valves (located on the outrigger cylinders) simultaneously operate the boom-up control switch. This will allow the hydraulic system to build pressure.
3. After outriggers are positioned, return crane/outrigger selector to "crane" position.
4. Crane is now ready to operate.

For manual outriggers:

1. Pull lock pins to release jack leg or drop down outrigger and move to outermost lock position.
2. Make sure lock pins are reinstalled properly.
3. Lower outrigger pad to firm ground and adjust foot to take out slack.
4. Crane is now ready to operate.

QUALIFICATIONS FOR AND CONDUCT OF OPERATORS AND OPERATING PRACTICES

OPERATORS

- 1 Crane operation shall be limited to personnel with the following minimum qualifications:**
 - A. designated persons
 - B. trainees under the direct supervision of a designated person
 - C. maintenance and test personnel (when it is necessary in the performance of their duties)
 - D. inspectors (crane).
- 2 No one other than the personnel specified above shall enter the operating area of a crane with the exception of persons such as oilers, supervisors, and those specified persons authorized by supervisors whose duties require them to do so and then only in the performance of their duties and with the knowledge of the operator or other persons.**

QUALIFICATIONS FOR OPERATORS

- 3 Operators shall be required by the employer to pass a practical operating examination. Qualifications shall be limited to the specific type of equipment for which examined.**
- 4 Operators and operator trainees shall meet the following physical qualifications:**
 - A. Vision of at least 20/30 Snellen in one eye and 20/50 in the other, with or without corrective lenses.
 - B. Ability to distinguish colors, regardless of position, if colors differentiation is required for operation.
 - C. Adequate hearing with or without hearing aid for the specific operation.
- 5 Evidence of physical defects or emotional instability which render a hazard to operator or others, which in the opinion of the examiner could interfere with the operator's performance may be sufficient cause for disqualification. In such cases, specialized clinical or medical judgment and tests may be required.**
- 6 Evidence that the operator is subject to seizures or loss of physical control shall be sufficient reason for disqualification. Specialized medical tests may be required to determine these conditions.**

- 7 Operators and operator trainees should have normal depth perception, coordination, and no tendencies to dizziness or similar undesirable characteristics.**
- 8 In addition to the above listed requirements, the operator shall:**
 - A. Demonstrate the ability to comprehend and interpret all labels, operator's manuals, safety codes and other information pertinent to correct crane operations.
 - B. Possess knowledge of emergency procedures and implementation of same.
 - C. Demonstrate to the employer the ability to operate the specific type of equipment.
 - D. Be familiar with the applicable safety regulations.
 - E. Understand responsibility for maintenance requirements of crane.
 - F. Be thoroughly familiar with the crane and its control functions.
 - G. Understand the operating procedures as outlined by the manufacturer.

CONDUCT OF OPERATORS

- 9 The operator shall not engage in any practice which will divert his attention while actually operating the crane.**
- 10 Each operator shall be responsible for those operations under the operator's direct control. Whenever there is any doubt as to safety, the operator shall consult with the supervisor before handling the loads.**
- 11 The operator should not leave a suspended load unattended unless specific precautions have been instituted and are in place.**
- 12 If there is a warning sign on the switch or engine starting controls, the operator shall not close the switch or start the engine until the warning sign has been removed by the appointed person.**
- 13 Before closing the switch or starting the engine, the operator shall see that all controls are in the "OFF" or neutral position and all personnel are in the clear.**
- 14 If power fails during operation, the operator shall:**
 - A. move power controls to the "OFF" or neutral position.

QUALIFICATIONS FOR AND CONDUCT OF OPERATORS AND OPERATING PRACTICES

B. land the suspended load and boom, if practical.

15 The operator shall be familiar with the equipment and its proper care. If adjustments or repairs are necessary, the operator shall report the same promptly to the appointed person, and shall also notify the next operator.

16 All controls shall be tested by the operator at the start of each shift. If any controls do not operate properly, they shall be adjusted or repaired before operations are begun.

17 Stabilizers shall be visible to the operator while extending or setting unless operator is assisted by a signal person.

OPERATING PRACTICES

HANDLING THE LOAD

18 Size of load

- A. No crane shall be loaded beyond the rated load except for test purposes.
- B. The load to be lifted is to be within the rated load of the crane and its existing configuration.
- C. When loads which are not accurately known are to be lifted, the person responsible for the job shall ascertain that the weight of the load does not exceed the crane rated load at the radius at which the load is to be lifted.

19 Attaching the load

- A. The load shall be attached to the hook by means of slings or other devices of sufficient capacity.
- B. Hoist rope shall not be wrapped around the load.

20 Moving the load

- A. The operator shall determine that:
- B. The crane is level and, where necessary, the vehicle/carrier is blocked properly.
- C. The load is well secured and balanced in the sling or lifting device before it is lifted more than a few inches.
- D. Means are provided to hold the vehicle stationary while operating the crane.
- E. Before starting to lift, the hook shall be brought over the load in such a manner as to minimize swinging.

F. During lifting care shall be taken that:

- 1. there is no sudden acceleration or deceleration of the moving load.**
- 2. load, boom or other parts of the crane do not contact any obstruction.**

G. Cranes shall not be used for dragging loads sideways.

H. This standard recognizes that articulating boom cranes are designed and intended for handling materials. They do not meet personnel lift or elevator requirements. Therefore, no lifting, lowering, swinging or traveling shall be done while a person is on the hook or load. Hook attached suspended work platforms (baskets) shall not be used with cranes covered by this standard. Work platforms attached to the boom must be approved by crane manufacturer.

I. The operator should avoid carrying loads over people.

J. When the crane is so equipped, the stabilizers shall be fully extended and set. Blocking under stabilizers shall meet the requirements as follows:

- 1. strong enough to prevent crushing.**
- 2. of such thickness, width and length as to completely support the stabilizer pad.**

K. Firm footing under all tires, or individual stabilizer pads should be level. Where such a footing is not otherwise supplied, it should be provided by timbers, cribbing, or other structural members to distribute the load so as to not exceed allowable bearing capacity or the underlying material.

L. In transit, the boom shall be carried in stowed position.

M. When rotating the crane, sudden starts and stops shall be avoided. rotational speed shall be such that the load does not swing out beyond the radius at which it can be controlled.

N. The crane shall not be transported with a load on the hook unless recommended by the manufacturer.

O. No person should be permitted to stand or pass under a suspended load.

21 Stowing procedure. Follow the manufacturer's procedure and sequence when stowing and un-stowing the crane.

QUALIFICATIONS FOR AND CONDUCT OF OPERATORS AND OPERATING PRACTICES

MISCELLANEOUS

OPERATING NEAR ELECTRICAL POWER LINES

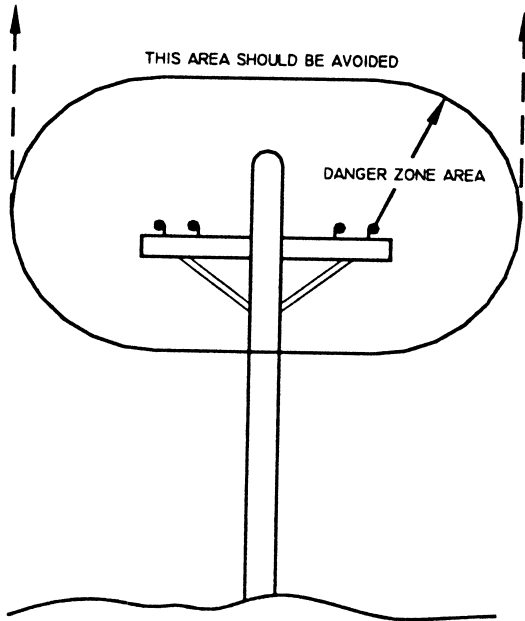

22 Cranes shall be operated so that no part of the crane or load enters into the danger zone shown above.

EXCEPTIONS

- A. The danger zone may be entered after confirmation by an appointed person that the electrical distribution and transmission lines have been de-energized and visibly grounded at the point of work; or
- B. The danger zone may be entered if insulating barriers (not a part of nor an attachment to the crane) have been erected to prevent physical contact with the lines.

23 For lines rated 50 kV or below, minimum clearance between the lines and any part of the crane or load (including handling appendages) shall be 10 ft. (3m). For higher voltages, see Table 1.

24 Caution shall be exercised when working near overhead lines, because they can move horizontally or vertically due to wind, moving the danger zone to new positions.

25 In transit with no load and boom lowered the clearance shall be specified in Table 1.

26 A qualified signalperson shall be assigned to observe the clearance and give warning before approaching the above limits.

- A. Any overhead wire shall be considered to be an energized line unless and until the person owning such line or the electrical utility authorities verify that it is not an energized line.
- B. Exceptions to this procedure, if approved by the administrative or regulatory authority if the alternate procedure provides equivalent protection and set forth in writing.
- C. Durable signs shall be installed at the operator's station and on the outside of the crane, warning that electrocution or serious bodily injury may occur unless a minimum clearance of 10 ft. (3.0m) between the crane or the load being handled and energized power lines. Greater clearances are required because of higher voltage as stated above. These signs shall be revised but not removed when local jurisdiction requires greater clearances.

TABLE 1

normal voltage, kV (phase to phase)		minimum required clearance	
		ft	(m)
<u>when operating near high voltage power lines</u>			
over	to 50	10	(3.05)
over	50 to 200	15	(4.6)
over	200 to 350	20	(6.1)
over	350 to 500	25	(7.62)
over	500 to 750	35	(10.67)
over	750 to 1000	45	(13.72)
<u>while in transit with no load and boom lowered</u>			
over	to 0.75	4	(1.22)
over	0.75 to 50	6	(1.83)
over	50 to 345	10	(3.83)
over	345 to 750	16	(4.87)
over	750 to 1000	20	(6.1)

INSPECTION, TESTING AND MAINTENANCE

GENERAL

INSPECTION CLASSIFICATION

27 Initial inspection. Prior to initial use, all new, altered, modified or extensively repaired cranes shall be inspected by a designated person to insure compliance with provisions of this standard.

28 Regular inspection. Inspection procedure for cranes in regular service is divided into two general classifications based upon the intervals at which inspection should be performed. The intervals in turn are dependent upon the nature of the components of the crane and the degree of their exposure to wear, deterioration, or malfunction. The two general classifications are herein designated as "frequent" and "periodic" with respective intervals between inspections as defined below.

- A. frequent inspection - daily to monthly intervals
- B. periodic inspection - one to twelve intervals, or as specifically recommended by the manufacturer

FREQUENT INSPECTION

29 Inspection shall be performed by designated personnel.

- A. control mechanisms for maladjustment interfering with proper operation - daily, when used
- B. control mechanisms for excessive wear of components and contamination by lubricants or other foreign matter
- C. safety devices for malfunction
- D. all hydraulic hoses, particularly those which flex in normal operation of crane functions, should be visually inspected once every working day, when used
- E. hooks and latches for deformation, chemical damage, cracks, and wear. Refer to ANSI/ASME B30.10
- F. rope reeving for compliance with crane manufacturer's specifications, if optional winch is used

G. electrical apparatus for malfunctioning, signs of excessive deterioration, dirt and moisture accumulation

H. hydraulic system for proper oil level and leaks daily

I. tires for recommended inflation pressure, cuts and loose wheel nuts

J. connecting pins and locking device for wear and damage

PERIODIC INSPECTION

30 Deformed, cracked or corroded members in the crane structure and carrier.

31 Loose bolts, particularly mounting bolts.

32 Cracked or worn sheaves and drums.

33 Worn, cracked, or distorted parts such as pins, bearings, shafts, gears, rollers and devices.

34 Excessive wear on brake and clutch system parts and lining.

35 Crane hooks inspected for cracks.

36 Travel steering, braking, and locking devices, for malfunction.

37 Excessively worn or damaged tires.

38 Hydraulic and pneumatic hose, fittings, and tubing inspection.

A. evidence of leakage at the surface of the flexible hose or its junction with metal and coupling

B. blistering, or abnormal deformation to the outer covering of the hydraulic or pneumatic hose

C. leakage at threaded or clamped joints that cannot be eliminated by normal tightening or recommended procedures

D. evidence or excessive abrasion or scrubbing on the outer surface of a hose, rigid tube, or fitting. Means shall be taken to eliminate the interference of

INSPECTION, TESTING AND MAINTENANCE

GENERAL

elements in contact or otherwise protect the components

necessary to determine origin of the problem before corrective action can be taken.

39 Hydraulic and pneumatic pumps and motors inspection.

- A. loose bolts or fasteners
- B. leaks at joints between sections
- C. shaft seal leaks
- D. unusual noises or vibrations
- E. loss of operating speed
- F. excessive heating of the fluid
- G. loss of pressure

40 Hydraulic and pneumatic valves inspection.

- A. cracks in valve housing
- B. improper return of spool to neutral position
- C. leaks at spools or joints
- D. sticking spools
- E. failure of relief valves to attain or maintain correct pressure setting
- F. relief valve pressure shall be checked as specified by the manufacturers

41 Hydraulic and pneumatic cylinders inspection.

- A. drifting caused by fluid leaking across piston
- B. rod seals leaking
- C. leaks at welding joints
- D. scored, nicked, or dented cylinder rods
- E. damaged case (barrel)
- F. loose or deformed rod eyes or connecting joints

42 Hydraulic filters. Evidence of rubber particles on the filter elements may indicate hose, "O" ring, or other rubber component deterioration. Metal chips or pieces on the filter may denote failure in pumps, motors, or cylinders. Further checking will be

43 Labels are to be in place and legible.

CRANES NOT IN REGULAR USE

44 A crane which has been idle for a period of over one month or more, but not less than six months, shall be given an inspection conforming with the initial-regular- frequent inspections.

45 A crane which has been idle for a period of over six months shall be given a complete inspection conforming with the initial-regular-frequent inspection requirements.

INSPECTION RECORDS

46 Dated records for periodic inspection should be made on critical items such as brakes, crane hooks, rope, hydraulic and pneumatic cylinders, and hydraulic and pneumatic relief pressure valves. Records should be kept available to an appointed person.

OPERATIONAL TESTS

47 Prior to initial use, all new, altered, modified, or extensively repaired cranes shall be tested for compliance with the operational requirements of this section, including functions such as the following:

- A. load lifting and lowering mechanisms
- B. boom lifting and lowering mechanisms
- C. boom extension and retraction mechanisms
- D. swing mechanisms
- E. safety devices
- F. operating controls comply with appropriate function labels

Operational crane test results shall be made available to an appointed person.

RATED TEST LOAD

Prior to initial use, altered, modified, or extensively repaired cranes shall be load

INSPECTION, TESTING AND MAINTENANCE

GENERAL

tested by or under the direction of an appointed person.

48 Test loads shall not exceed 110% of the manufacturer's load ratings.

49 Written reports shall be maintained showing test procedures and confirming the adequacy of repairs.

MAINTENANCE

PREVENTIVE MAINTENANCE

50 Before adjustment and repairs are started on a crane, the following precautions shall be taken as applicable:

- A. crane placed where it will cause the least interference with other equipment or operations
- B. all controls at the "off" position
- C. starting means rendered inoperative
- D. boom lowered to the ground if possible or otherwise secured against dropping
- E. relieve hydraulic oil pressure from all hydraulic circuits before loosening or removing hydraulic components

51 Warning or "OUT OF ORDER" signs shall be placed on the crane controls.

52 After adjustments and repairs have been made, the crane shall not be returned to service until all guards have been reinstalled, trapped air removed from hydraulic system (if required), safety devices reactivated, and maintenance equipment removed.

ADJUSTMENTS AND REPAIRS

53 Any hazardous conditions disclosed by the inspection requirements shall be corrected before operation of crane is resumed, Adjustments and repairs shall be done only by designated personnel.

54 Adjustments shall be maintained to assure correct functioning of components, The following are examples:

- A. functional operating mechanism
- B. safety devices
- C. control systems

55 Repairs or replacements shall be provided as needed for operation.

The following are examples:

- A. critical parts of functional operating mechanisms which are cracked, broken, corroded, bent, or excessively worn
- B. critical parts of the crane structure which are cracked, bent, broken, or excessively corroded
- C. crane hooks showing cracks, damage, or corrosion shall be taken out of service. Repairs by welding are not recommended

56 Instructions shall be provided by the manufacturer for the removal of air from hydraulic circuits.

LUBRICATION

All moving parts of the crane, for which lubrication is specified, should be regularly lubricated per the manufacturer's recommendations and procedures.

ROPE INSPECTION

57 Frequent Inspection

- A. All running ropes in service should be visually inspected once each working day. A visual inspection shall consist of observation of all rope which can be in use during the days operations. These visual observations should be considered with discovering gross damage such as listed below, which may be an immediate hazard.

- 1. distortion of the rope such as kinking, crushing, un-stranding, birdcaging, main strand displacement, or core protrusion. Loss of rope diameter in a short length or unevenness of outer strands should be replaced**

- 2. general corrosion**

INSPECTION, TESTING AND MAINTENANCE

GENERAL

3. broken or cut strands;
4. number, distribution and type of visible broken wires. When such damage is discovered, the rope shall either be removed from service or given as inspection.

B. Care shall be taken when inspecting sections of rapid deterioration such as flange points, crossover points, and repetitive pickup points on drums.

58 Periodic inspection

A. The inspection frequency shall be determined by a qualified person and shall be based on such factors as:

1. expected rope life as determined by experience on the particular installation or similar installations
2. severity of environment
3. percentage of capacity lifts
4. frequency rates of operation
5. exposure to shock loads

Inspection need not be at equal calendar intervals and should be more frequent as the rope approaches the end of its service life. This inspection shall be made at least annually.

B. Periodic inspection shall be performed by a designated person. This inspection shall cover the entire length of the rope. Only the surface wires need be inspected. No attempt should be made to open the rope. Any deterioration results in appreciable loss of original strength, such as described below, shall be noted and determination made as to whether use of the rope would constitute a hazard: points listed above reduction of rope diameter below nominal diameter due to loss of core support, internal or external corrosion, or wear of outside wires; severely corroded, cracked, bent, worn or improperly applied connections;

C. Care shall be taken when inspecting sections subject to rapid deterioration such as the following:

1. sections in contact with saddles, equalizer sheaves, or other sheaves where rope travel is limited
2. sections of the rope at or near terminal ends where corroded or broken wires may protrude

ROPE REPLACEMENT

59 No precise rules can be given for determination of the exact time for replacement of rope, since many variable factors are involved.

Continued use in this respect depends upon good judgement by a designated person in evaluating remaining strength in a used rope after allowance for deterioration disclosed by inspection. Continued rope operation depends upon this remaining strength.

60 Conditions such as the following shall be reason for questioning continued use of the rope or increasing the frequency of inspection:

- A. in running ropes, six randomly distributed broken wires in one lay or three broken wires in one strand in one lay
- B. one outer wire broken at the contact point with the core of the rope structure and protrudes or loops out of the rope structure. Additional inspection of this section is required
- C. wear of one third of the original diameter of the outside individual wire
- D. kinking, crushing, birdcaging, or any other damage resulting in distortion of the rope structure
- E. evidence of any heat damage from any cause
- F. reduction from nominal diameter of more than 1/64 in. (0.4mm) for diameters up to and including 5/16 in. (8 mm), 1/32 in. (0.8 mm) for diameter 3/8 in. (9.5 mm) to and including 1/2 in. (13 mm), 3/64 in. (1.2 mm) for diameter 9/16 in. (14.5 mm) to and including 3/4 in. (19 mm). 1/16 in. (1.6 mm) for diameter 7/8 in. (22 mm) to and including 11/8 in. (29 mm), 3/32 in. (2.4 mm) for diameters 11/4 in. (32 mm) to and including 11/2 in. (38 mm)

INSPECTION, TESTING AND MAINTENANCE

GENERAL

G. In standing ropes, more than two broken wires in one lay in sections beyond end connections or more than one broken wire at an end connection.

H. Replacement rope shall have a strength rating at least as great as the original rope furnished or recommended by the crane manufacturer. Any deviation from the original size, grade, or construction shall be specified by a rope manufacturer, or a qualified person.

61 Rope not in regular use: all rope which has been idle for a period of a month or more due to shutdown or storage of a crane on which it is installed, shall be given an inspection in accordance with above information before it is placed in service. This inspection shall be for all types of deterioration and shall be performed by a qualified person.

62 Inspection records

- A. frequent inspection- no records required
- B. periodic inspections- in order to establish data as a basis for judging the proper time for replacement, a dated report condition at each periodic inspection should be kept on file. This report shall cover points of deterioration listed above.

ROPE MAINTENANCE

63 Rope should be stored to prevent damage or deterioration.

64 Unreeling or uncoiling of rope shall be done as recommended by the rope manufacturer and with care to avoid kinking or inducing twist.

65 Before cutting a rope, seizing shall be placed on each side of the place where the rope is to be cut to prevent unlaying of the strands. On pre-formed rope, one seizing on each side of the cut is required. On non-preformed ropes of 7/8 in. (22 mm) diameter or smaller, two seizings on each side of the cut are required, and for non-preformed rope 1 in. (25 mm) diameter or larger, three seizings on each side of the cut are required.

66 During installation care should be exercised to avoid dragging of the rope in the dirt or around objects which will scrape, nick crush or induce sharp bends in it.

67 Rope should be maintained in a well-lubricated condition. It is important that lubricant applied as a part of a maintenance program shall be compatible with the original lubricant and to this end the rope manufacturer should be consulted. Lubricant applied shall be the type which does not hinder visual inspection. Those sections of rope which are located over sheaves or otherwise hidden during inspection and maintenance procedures require special attention when lubricating rope. The object of rope lubrication is to reduce internal friction and to prevent corrosion.

68 When an operating rope shows greater wear or well defined localized areas than on the remainder of the rope, rope life can be extended in cases where a section at the worn end, and thus shifting the wear to different areas of the rope.

MOUNTING and INSTALLATION 6006

1. Check to make sure the following items are with your crane:

ITEM	PART NO.	DESCRIPTION
1.	366203000	Swivel Block
2.	366212000	Vented Relief Valve (Non-proportional Units Only)
3.	480525000	Control Valve Assembly (Proportional Units Only)
4.	480018000	Pump Assembly (Optional)
5.	999946000	Owners Manual
6.	015104000	Bolt system: 7/8 NF x 5", Grade 8, (4 Req'd)

2. Pressure and return hoses are not furnished with this crane. The hoses must be provided by the installer and the lengths determined at installation.

REQUIREMENTS FOR INSTALLATION USING 8 GALLON RESERVOIR WITH RELIEF VALVE AND AUTO CRANE PROVIDED PUMP

A. RETURN LINE FROM CRANE TO RESERVOIR (IN COMPARTMENT): -8 SAE 100R2 (OR EQUIVALENT). HOSE LENGTH IS DETERMINED BY INSTALLER. RETURN LINES LONGER THAN 6 FEET SHOULD BE SIZE -12. HOSE END FITTINGS ARE -8 JIC FEMALE SWIVEL (CRANE END) AND -10 JIC FEMALE SWIVEL (RESERVOIR END).

B. PRESSURE LINE FROM VENTED RELIEF VALVE TO CRANE: -8 SAE 100R2 (OR EQUIVALENT). HOSE LENGTH IS DETERMINED BY INSTALLER. HOSE END FITTINGS ARE BOTH -8 JIC FEMALE SWIVEL.

NOTE: CRANE MUST USE RELIEF VALVE P/N 366212, WHICH IS PROVIDED.

C. SUCTION HOSE FROM PUMP TO RESERVOIR: -16 HYDRAULIC SUCTION HOSE WITH TWO (2) -16 HOSE CLAMPS ON EACH END.

D. PRESSURE LINE FROM PUMP TO VENTED RELIEF VALVE (LOCATED ON RESERVOIR) : -12 SAE 100R2 (OR EQUIVALENT). HOSE LENGTH IS DETERMINED BY INSTALLER. HOSE END FITTINGS ARE BOTH -10 JIC FEMALE SWIVEL.

NOTE:

REFER TO OWNERS MANUAL FOR ADDITIONAL INSTALLATION INFORMATION, AND OTHER RESERVOIR AND PUMP COMBINATIONS.

CAUTION - FAILURE TO USE CLEAN HYDRAULIC HOSES AND COMPONENTS MAY CONTAMINATE THE CRANE AND HYDRAULIC SYSTEM AND VOID WARRANTY.

- Crane must be provided with a flow of 8 gallons per minute and a pressure of 2200 PSI. Excess flow will cause erratic operation, and too little flow will cause poor crane operation.
- Vehicle should meet minimum GVW rating of 14,500 pounds.
- The vehicle **MUST** be equipped with an engine speed control and tachometer.
- Make sure mounting surface is properly reinforced to withstand 36,000 ft-lb capacity loading of crane and that outriggers are used to provide total stability for the truck.
- A 13 1/2" dia. hole should be cut out of mounting location (centered with mounting bolts) for access to lower ring gear bolts and hydraulic connections.
- Make sure the mounting bolts are 7/8x dia, grade 8. Torque bolts to 440 ft-lbs (dry).
- When crane is not in operation, a boom support should always be used. Traveling block should be connected to hood loop.
- Always use cable loops on side of boom and pendant guard on side of pedesal to store pendant assembly, if this type of storage applies.

MOUNTING and INSTALLATION 6006

11. **CHECK FOR PROPER PRESSURE AND RETURN LINE HOOK-UP TO CRANE:**
PRESSURE PORT IS ON RIGHT SIDE AS VIEWED FROM THE REAR OF THE CRANE.
12. Use medium pressure Auto Crane filter in the return line unless filter exit port is mounted directly to the reservoir.
13. Electrical hookup:
 - NON-REMOVABLE PENDANT UNITS:**
 - A. RUN THE FOLLOWING WIRES THROUGH HOLE IN BASE ASSEMBLY OF CRANE AND SEAL WITH SILICONE RUBBER TO PREVENT WIRE CHAFING AND LEAKS.
 - B. CONNECT WIRE FROM DIRECTIONAL VALVE SOLENOID (P/N 480137) TO WHITE WIRE W/ TRACER AT PENDANT CABLE END.
 - C. CONNECT POWER CONDUCTOR FROM STARTER SOLENOID TO BLACK WIRE AT BASE OF CRANE, PASSING THROUGH THE MAIN POWER RELAY. USE THE IN-LINE FUSE PROVIDED.
 - removable pendant units:
 - A. OBTAIN THE PROPER WIRING DIAGRAM.
 - B. WIRE TERMINAL STRIP PER DIAGRAM AND PROTECT STRIP FROM ACCIDENTAL CONTACT.

WARNING! FAILURE TO CORRECTLY PLUMB AND WIRE CRANE CAN CAUSE INADVERTENT OPERATION AND DAMAGE TO CRANE AND/OR PERSONNEL!

14. Once crane and plumbing are installed on the truck, fill the reservoir to top of sight glass (mobil DTE 13 or equal). Before operating crane, connect together the pressure and return hoses going to base of crane using -8 JIC union and engage PTO with engine running. Allow oil to circulate for 15 to 20 minutes. This will flush contaminants from the system back to the return line filter. Operate all cylinders to full extension and retraction a minimum of six times, to bleed air from system. Return all cylinders to the stored position and disengage PTO. Refill reservoir to top sight glass. To ensure 8 gallons per minute (GPM), install an in-line flow meter between the crane and the reservoir in the return hose, or confirm pump speed pump speed is correct. The proper speed for Auto Crane gear pump P/N 480018 is 1000 RPM.
15. Proper pressure setting can be achieved by, with the PTO disengaged, removing the pipe plug on the pipe plug on the vented relief valve or proportional valve and installing a 2500 PSI pressure gauge. Extend the boom "in" all the way and continue holding the switch on. For proportional systems, the trigger should be pulled completely back (on). Read the pressure gauge and adjust relief valve to read 2200 PSI. Recheck pressure setting to verify adjustment.
16. Load test the crane to ensure proper functioning and truck stability.
17. Make certain the owner's manual is delivered to the customer.
18. For additional help: call the service department at the Auto Crane Company. (918) 836-0463 (TULSA, OKLAHOMA)

MOUNTING and INSTALLATION 6006

WARNING

FEDERAL LAW (49 CFR PART 571) REQUIRES THAT THE FINAL STAGE MANUFACTURER OF A VEHICLE CERTIFY THAT THE VEHICLE COMPLIES WITH ALL APPLICABLE FEDERAL REGULATIONS. ANY MODIFICATIONS PERFORMED ON THE VEHICLE PRIOR TO THE FINAL STAGE ARE ALSO CONSIDERED INTERMEDIATE STAGE MANUFACTURING AND MUST BE CERTIFIED AS TO COMPLIANCE. THE INSTALLER OF THIS CRANE AND BODY IS CONSIDERED ONE OF THE MANUFACTURERS OF THE VEHICLE. AS SUCH A MANUFACTURER, THE INSTALLER IS RESPONSIBLE FOR COMPLIANCE WITH ALL APPLICABLE FEDERAL AND STATE REGULATIONS, AND IS REQUIRED TO CERTIFY THAT THE VEHICLE IS IN COMPLIANCE.

IT IS THE FURTHER RESPONSIBILITY OF THE INSTALLER OF THE CRANE TO COMPLY WITH THE **OSHA** TRUCK CRANE STABILITY REQUIREMENTS AS SPECIFIED BY 29 CFR PART 1910.180 (C) (1).



AUTO CRANE COMPANY
Tulsa, Oklahoma

Safety Decal Section 6006

Revision 8/97

ITEM	DESCRIPTION	QTY	FIG
1	CAUTION, WORK RULES	1	SD-1
2	DANGER, OPERATOR TRAINING	1	SD-2
3	CAUTION, TWECO	1	SD-3
4	DANGER, ELECTROCUTION HAZARD	2	SD-4
5	DANGER, STAY CLEAR OF BOOM	2	SD-5
6	DANGER, STAY CLEAR OF LOAD	2	SD-6
7	WARNING, KEY OPERATION	1	SD-7

Safety Decal Section

6006

Revised 8/97

PART NO.: 040579
DECAL: OPERATION INSTRUCTIONS
FUNCTION: To inform the operator of the proper procedure to follow for safe operation of the crane.
USED ON: All cranes
QUANTITY: 1
PLACEMENT: Right side of crane
:

FIG.

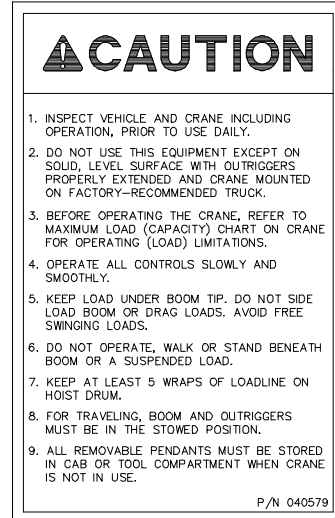

PART NO.: 040580
DECAL: OPERATOR TRAINING
FUNCTION: To inform the operator of the need to receive proper training before using the crane.
USED ON: All cranes
QUANTITY: 1
PLACEMENT: Right side of crane

FIG. SD-2

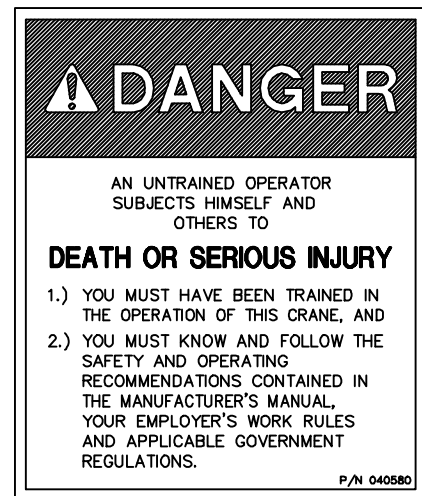

PART NO.: 040530
DECAL: CAUTION - TWECO/LIVE
FUNCTION: To inform the operator that the main power feeder (tweco) is "LIVE" when crane battery is connected.
USED ON: 6006
QUANTITY: 1
PLACEMENT: Back of crane

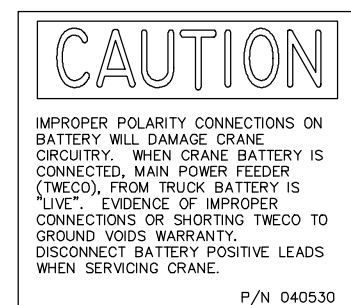

FIG. SD-3

Safety Decal Section

6006

Revised 8/97

PART NO.: 040529
DECAL: ELECTROCUTION HAZARD
FUNCTION: To inform the operator of the hazard involved with contacting electrical power lines with crane boom.
USED ON: Articulated & Stiff Boom Cranes
QUANTITY: 2
PLACEMENT: Both sides of boom

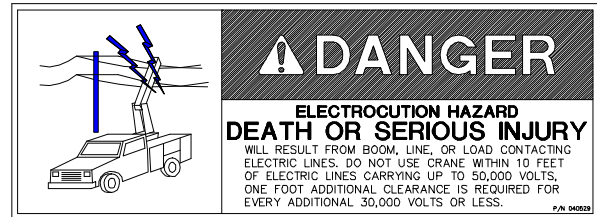

FIG. SD-4

PART NO.: 040517
DECAL: STAY CLEAR OF BOOM
FUNCTION: To inform the operator of the hazard of proximity or contact with the crane boom during operation.
USED ON: All cranes
QUANTITY: 2
PLACEMENT: Both sides of end of boom



FIG. SD-5

PART NO.: 040518
DECAL: STAY CLEAR OF LOAD
FUNCTION: To inform the operator of the hazard of proximity or contact with the crane load during operation.
USED ON: All cranes
QUANTITY: 2
PLACEMENT: Both sides of block

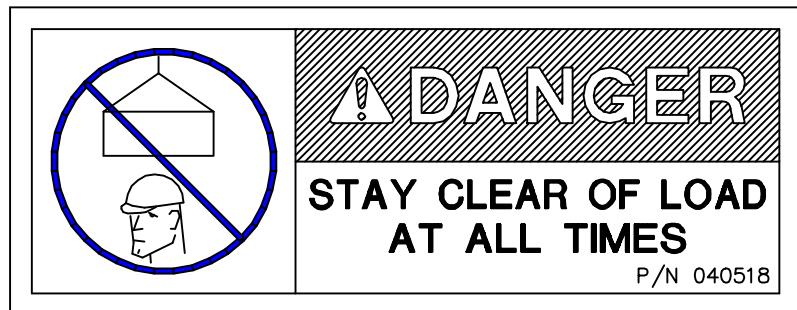

FIG. SD-6

Safety Decal Section 6006

Revised 8/97

PART NO.: 040511
DECAL: WARNING & CAUTION
FUNCTION: To inform the operator of the proper procedure regarding key operation.
USED ON: 6006
QUANTITY: 1
PLACEMENT: Right side of crane

WARNING

TO OPERATE UNIT INSERT KEY AND TURN TO ON POSITION. WHEN NOT USING CRANE TURN KEY TO OFF POSITION AND REMOVE KEY.

CAUTION

DO NOT LEAVE KEY IN SWITCH WHEN CRANE IS NOT IN USE, WHEN PARKED, DRIVING TO AND FROM LOCATION, OR OVERNIGHT.

ANY WARRANTY EXPRESSED OR IMPLIED BY MANUFACTURER WILL BE NULL AND VOID IF KEY IS LEFT IN SWITCH WHEN CRANE IS NOT IN USE.



AUTO CRANE COMPANY
TULSA, OK

P/N 040511

FIG. SD-7

LIFE OF WIRE LINE

So many variable factors can cause the deterioration of wire line cable that it is not possible to determine a definite life expectancy. Some of these factors are:

- **Load being handled.**
- **Corrosive conditions.**
- **Maintenance of the unit:**
 - Keep the sheaves turning freely.
 - Maintain tension on cable to insure proper spooling.
 - Avoid kinks in cable.
 - Avoid abrasive action and contact with sharp corner.
- **Frequency of use.**

Auto Crane units, up to 2,400 pound ratings use 3/16 inch diameter galvanized pre-formed 7 x 19 aircraft cable. This cable has a working strength, when new, of 4,200 pounds. It is recommended when 1,200 pound loads are exceeded to use a two part line with a traveling block. This will ensure a 3.5 to 1 safety factor when the cable is new.

Keeping the above factor of safety in mind and knowing the kind of loads that will be handled, the user can determine by inspection of the cable as to when it should be replaced.

Items to look for while inspecting the cables are:

- Broken strands.
- Kinks and flattened sections.
- Corrosion and abrasion.

WIRE LINE LUBRICATION

Lubrication of the wire line serves two important purposes:

- Prevent corrosion.
- Reduce wear due to flexing and abrasion caused by contact with the sheaves, rollers, and cable on the drum.

Preparation

Remove rust and foreign matter with a wire brush and wipe clean. Be sure cable is dry.

Application

Method 1: Dip a brush into a light weight motor oil and apply. In some cases, dip a rag or a piece of sheepskin into the lubricant and swab the lubricant on to the rope.

Method 2: Apply a heavier lubricant such as a grease gun lubricant with hands while wearing leather gloves. (Leather gloves give greater protection and less penetration of the grease than canvas gloves.)

LUBRICATION CHART

6006

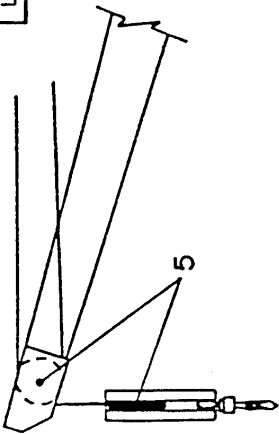
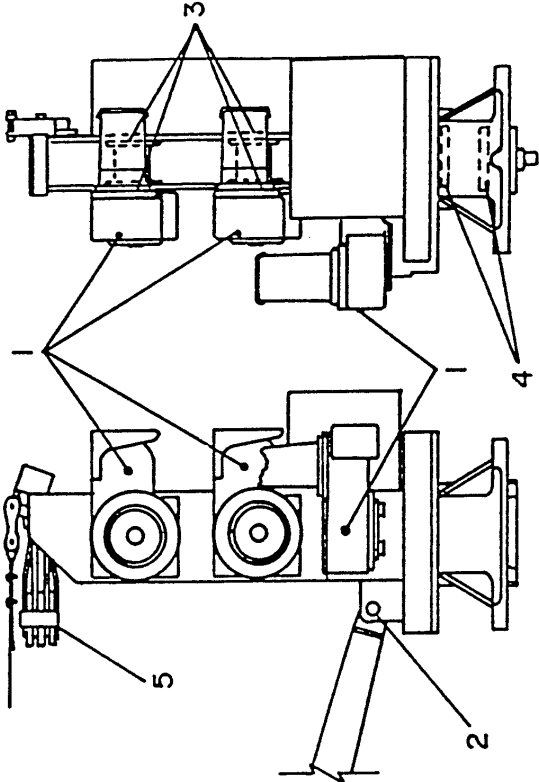
CHG LTR	REVISIONS	DATE	APP'D
	DESCRIPTION		
			
<p>1. ACTUATOR GEAR CASES: Maintain oil level at points indicated. Use extreme pressure gear lube (E.P. 80-90).</p> <p>2. BOOM HINGE POINT: 3 strokes with grease gun every 15 days. Use chassis lubricant.</p> <p>3. DRUM SHAFT BALL BEARINGS: Sealed for life. No lube required.</p> <p>4. QUILL TAPER ROLLER BEARINGS: Packed at factory. No lube required unless disassembled. Use chassis lubricant.</p> <p>5. SHEAVE ROLLER BEARINGS: Sealed type. No lube required.</p>			
NEXT ASSY			

QUANTITY	ITEM	D/S	PART NO.	DESCRIPTION
				AUTO CRANE COMPANY P.O. BOX 45548 • TULSA, OKLAHOMA 74145 9260 BROKEN ARROW EXPRESSWAY • 918-627-9475
				LUBRICATION CHART 5004 - 6006
				DRAWN BY <i>Heinrichs</i> DATE <i>4/23/81</i> CHK'D BY DATE ENG. BY DATE SCALE \sim SIZE A DRAWING NO. AW-1001 REVISION WEIGHT SHEET <u> </u> OF <u> </u>
<p>UNLESS OTHERWISE NOTED ALL DIMENSIONS ARE IN INCHES. TOLERANCES UNLESS OTHERWISE SPECIFIED:</p> <p>ANGLES \pm 1/2° .XX \pm .40 FRACTIONAL \pm 1/16 .XXX \pm .010 REMOVE ALL BURRS AND SHARP EDGES. DO NOT SCALE THIS DRAWING. TOLERANCES NOT SHOWN ABOVE ARE PER ANSI Y14.5-1973</p> <p>THIS PRINT IS THE PROPERTY OF AUTO CRANE CO. AND MUST NOT BE USED IN ANY MANNER DETRIMENTAL TO THEIR INTERESTS.</p>				

TROUBLESHOOTING

6006 SERIES

PROBLEM	CAUSE
Charging	Incorrect hookup of V.S.U., bad ground to truck chassis, bad battery not staying charged, not running, truck regulator or alternator problem.
Crane will operate on hoist down only.	Lost ground to other relays. Load limit switch kicked out.
Crane operates two functions at same time such as hoist up, turn right, boom down, turn right, etc.	Broken wire in pendant, head shorting to other terminals, function relay has stuck in operate position.
Boom will not go up	Boom limit switch not adjusted properly or broken, boom up relay stuck, broken wire in pendant, boom up switch is bad.
Crane will not operate in any single motor function such as boom down, hoist down, hoist up, turn right, turn left	Excluding boom limit switch, same as above; also check leads and motor brushes. Ground lost to any relay or all relays.
Crane will not operate at all	Check to make sure battery is connected in crane, power cable is connected to truck battery, key lock switch is turned on and properly connected, make sure of ground between crane and truck frame. Make sure battery in truck is connected. Check V.S.U. connection. Check grounds or relays and check load limit switch.
Motor or motors will not run	Check leads on motor; check brushes; broken wires in pendant, broken toggle switch, stuck relays. Check or see if motor or motors are getting 24 volts; if not check V.S.U. Check to see if both batteries are connected. Burned up fields and armatures also cause this.
Relays not functioning properly or stuck	Check relays using ohm meter. Relay should be closed on bottom end, open top end, use 12 volts to operate relays. Positive on one small post and negative on the other. This is top end when energized continuity should disappear at bottom and appear at top. When disconnected continuity should reappear at bottom. (Essex relay 200220)
Crane running slow – starts out good, then dies out	Battery in truck or crane or both is bad or low. Crane not grounded to truck chassis. Make sure motor and battery in truck are grounded to chassis relay in V.S.U. stuck or not grounded good. Connections on battery corroded not making good contact. Alternator or voltage regulator bad on truck; this causes battery not to fully charge.

TROUBLESHOOTING 6006 SERIES

PROBLEM

Pendant (or remote control) not operating crane properly

CAUSE

Broken toggle switches in control head; broken wires in control head or cable; control cable broken or not connected properly to terminal bar; wires from terminal bar to relays not connected or broken.

Bad ground circuit on relays
hoist up, boom up, boom down,
turn right, turn left

Loose connections on relays, load limit switch, diode, can cause crane not to operate properly; For example, when you try to operate more than one function at once, operation will work but the second will not. But each function will operate separately.

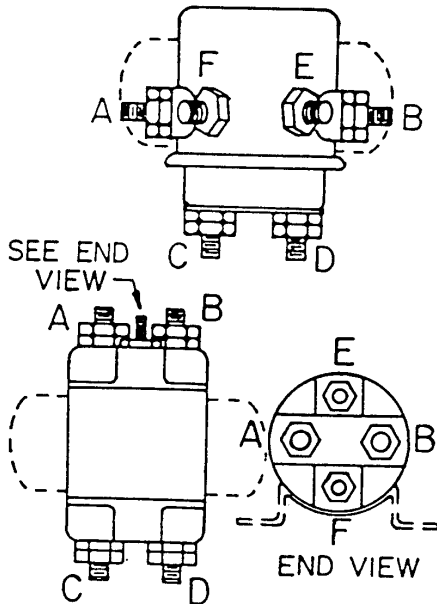

HOW TO CHECK RELAY:

To check a relay on this or any Auto Crane product is the same. The difference being in physical appearance. Shown at left are two types of relays Auto Crane uses. Our relays are normally closed across the bottom posts (C&D). When activated, they will open across (C&D) and close across (A&B). To activate these relays, use 12V positive and 12V negative wires and place them on posts (F&E). You may place 12V+ on post F or E as long as you place 12V on the remaining post (F&E) using a ohm meter or test light. Check across posts (A&B). You should get an ohm reading or your test light should be on when you have the relay activated. With the relay still activated check across posts (C&D). You should have no ohm reading or test light at this point with relay activated. (At this point, disconnect 12V+ and 12V- from posts (F&E). This should let relay return to its normal position. Using your ohm meter or test light again, check the relay across posts (A&B). If relay is working correctly, you should have no reading at all. Then check across posts (C&D). You should have an ohm reading or test light should be on. If you get the above results, relay is okay. If you get any variation in the above explanation on the relay you are checking, check the relay again. If it still shows a difference, the relay is bad and should be replaced.

NOTE - The above explanation is with relays completely disconnected from all wires on motor circuits and ground wires. These circuits can give you false readings sometimes.

GENERAL ASSEMBLY 6006 12/24 V

P/N 180000

NO	QTY	PART NO	DESCRIPTION	NO	QTY	PART NO	DESCRIPTION
1	1	233403	FEDESTAL	21	2	201520	BEARING (RET. DFLT)
2	1	234400	BASE ASSEMBLY	22	1	409900	BOOM DRUM
3	2	300002	ACTUATOR ASSEMBLY	23	2	002900	1/4-20NC X 3/8 SCREW
4	1	315302	TURNER ASSEMBLY	24	2	101024	1/4 X 1/4 X 4 HEX STOCK
5	1	676106	PANEL ASSEMBLY	25	4	307100	SPRIG LOCK RETAINING RING
6	1	305600	RELAY GUARD	26	4	400500	BEARING
7	1	400900	HOIST DRUM	27	1	241136	LOAD LIMIT SWITCH
8	6	001302	W8-32 X 1/2 HD MACH SCREW	28	1	013301	5/8-18 X 1/2 CAPSCREW GR B
9	6	009700	W8 LOCKWASHER	29	1	018100	5/8-18 HALF LOCK NUT
10	3	306600	SHIELD	30	2	330009	HINGE PIN
11	6	005900	1/4-20NC NUT (AS SPACER)	31	2	239000	GREASE ZERK
12	6	005900	3/8-16NC X 1/2 CAPSCREW	32	1	639700	BOOM LIMIT SWITCH
13	12	021001	3/8 LOCKWASHER	33	4	013000	7/8NF X 4 CAPSCREW GR 3
14	2	008700	3/8-16NC X 1/2 CAPSCREW	34	4	019500	7/8NF HEX NUT
15	1	302203	GEAR GUARD-LOWER	35	4	019500	7/8NF LOCKWASHER
16	9	004800	HO SELF TAPPING SHEET METAL SCW	36	1	662202	7/8NF LOCKWASHER
17	8	002603	SCREW HEX HD S.T. 12 X 1/2	37	3	308201	BRAKE ASSEMBLY
18	1	017200	3/8-24 THIN SELF-LOCKING NUT	38	1	330607	HYDRAULIC PUMP
19	1	009900	3/8-24NF X 3/2 CAPSCREW	39	1	REF	BOOM (10-18FT EXT) OPTIONAL
20	1	201903	ROLLER ASSEMBLY	40	1	REF	BOOM (14-20FT EXT) OPTIONAL
41	6	020600	WASHER, SPLK 5/16 NC CP	41	6	020600	WASHER, SPLK 5/16 NC CP
42	4	007200	SCREW HEX 5/16 NC CP	42	4	007200	SCREW HEX 5/16 NC CP
43	4	020901	WASHER, FLAT 5/16	43	4	020901	WASHER, FLAT 5/16
44	4	016500	NUT, HEX 5/16 NCCP	44	4	016500	NUT, HEX 5/16 NCCP
45	2	008701	SCREW, HEX 3/8 X 1 NC 03	45	2	008701	SCREW, HEX 3/8 X 1 NC 03
46	1	200876	ADAPTER, O-RING	46	1	200876	ADAPTER, O-RING
47	1	243152	HYDRAULIC HOSE	47	1	243152	HYDRAULIC HOSE
48	1	241188	BRACKET, TURNER	48	1	241188	BRACKET, TURNER
49	2	017301	NUT, HEX-1/2 3/8 NCCP 03	49	2	017301	NUT, HEX-1/2 3/8 NCCP 03
50	2	005900	SCREW HEX HD 1/4 X 3/4 NC 03	50	2	005900	SCREW HEX HD 1/4 X 3/4 NC 03
51	11	020500	WASHER, SPLK 1/4 CP	51	11	020500	WASHER, SPLK 1/4 CP
52	3	013500	NUT, HEX 1/4 NCCP 03	52	3	013500	NUT, HEX 1/4 NCCP 03
53	1	643700	TRUCK CABLE TIE	53	1	643700	TRUCK CABLE TIE
54	1	304500	WASHER, FLAT 1/2	54	1	304500	WASHER, FLAT 1/2
55	1	480780	PLATE, HOSE PROTECTOR	55	1	480780	PLATE, HOSE PROTECTOR
56	1	480780	PLATE, HOSE PROTECTOR	56	1	480780	PLATE, HOSE PROTECTOR
57	2	007801	SCREW HEX 1/2 X 3/4 NC 03	57	2	007801	SCREW HEX 1/2 X 3/4 NC 03
58	1	243180	SCREW HEX 1/2 X 3/4 NC 03	58	1	243180	SCREW HEX 1/2 X 3/4 NC 03
59	2	241175	ELL, 90P W/8 O-RING, JIC	59	2	241175	ELL, 90P W/8 O-RING, JIC
60	2	241170	ADAPTER, BLK HD 9/16-18 JIC	60	2	241170	ADAPTER, BLK HD 9/16-18 JIC
61	2	007808	SCREW, HEX HD 5/16 X 1/2 NF 03	61	2	007808	SCREW, HEX HD 5/16 X 1/2 NF 03
62	1	002900	SCREW, SET-CUP 1/4 X 3/8 NC	62	1	002900	SCREW, SET-CUP 1/4 X 3/8 NC
63	1	640700	SWITCH, RET-LOCK	63	1	640700	SWITCH, RET-LOCK
64	2	008900	SCREW, HEX HD 3/8 X 1 1/4 NC	64	2	008900	SCREW, HEX HD 3/8 X 1 1/4 NC
65	8	021200	WASHER, FLAT 3/8 SAE	65	8	021200	WASHER, FLAT 3/8 SAE
66	3	005601	SCREW, HEX HD 1/4 X 1 NCCP 03	66	3	005601	SCREW, HEX HD 1/4 X 1 NCCP 03
67	12	002100	SCREW, HEX HD 1/4 X 1 1/4 NCCP 03	67	12	002100	SCREW, HEX HD 1/4 X 1 1/4 NCCP 03
68	12	003900	NUT, HEX HD 1/4 X 1 1/4 NCCP 03	68	12	003900	NUT, HEX HD 1/4 X 1 1/4 NCCP 03
69	3	306400	SCREW, HEX HD 3/8 X 3/4 CP	69	3	306400	SCREW, HEX HD 3/8 X 3/4 CP
70	4	008400	SCREW, HEX HD 3/8 X 3/4 CP	70	4	008400	SCREW, HEX HD 3/8 X 3/4 CP
71	4	330372	NUT, HEX 3/8 NCCP	71	4	330372	NUT, HEX 3/8 NCCP
72	1	330612	HYD HOSE ASSEMBLY	72	1	330612	HYD HOSE ASSEMBLY
73	1	302004	SOLENOID VALVE	73	1	302004	SOLENOID VALVE
74	1	330613	CONDUCTOR ASSEMBLY	74	1	330613	CONDUCTOR ASSEMBLY

NOTE:
TORQUE MOUNTING
BOLTS AT 330 FT LBS
UPON ASSEMBLY.

B/88

GENERAL ASSEMBLY 6006 220/110 P/N 180003

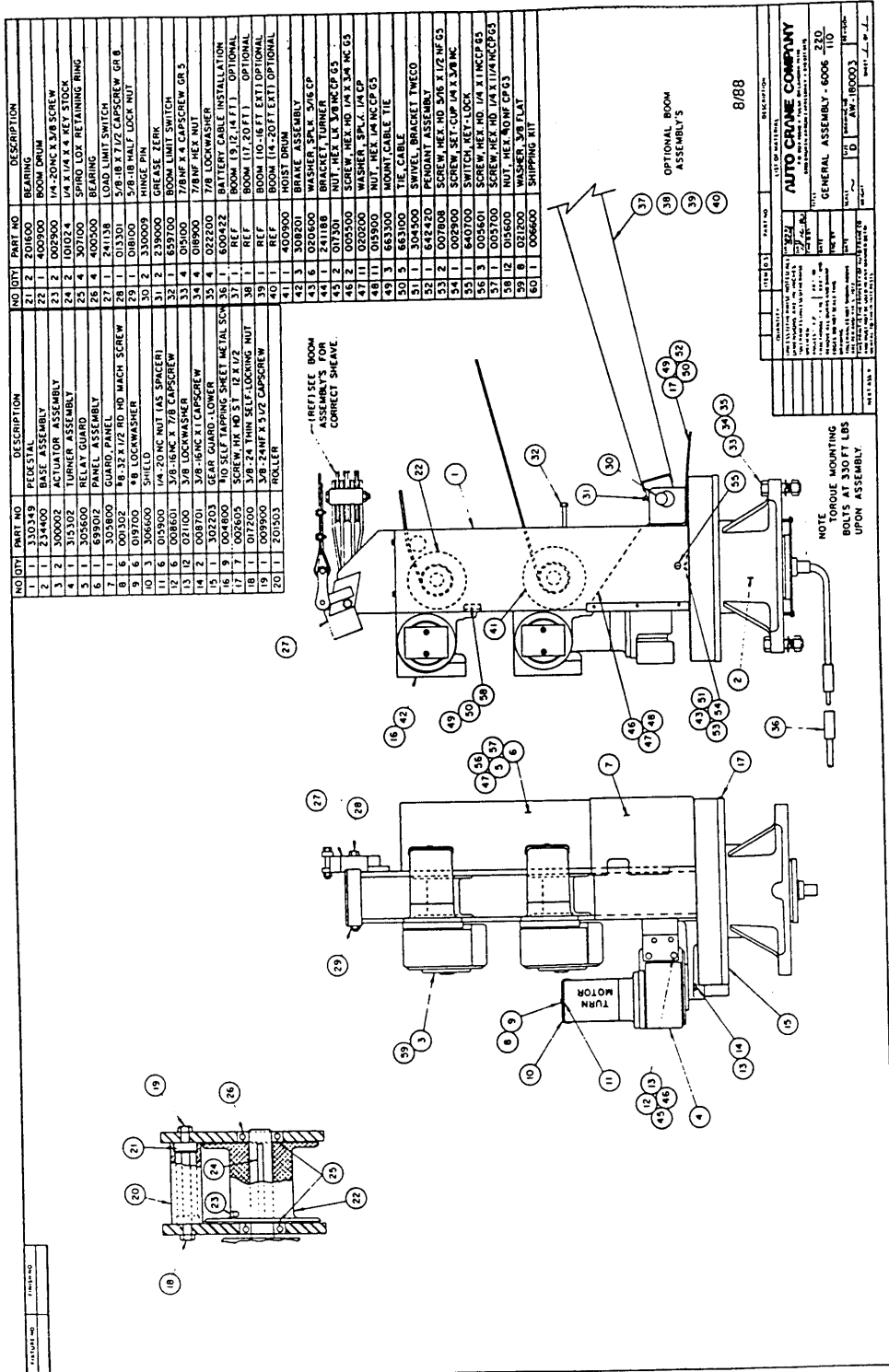

GENERAL ASSEMBLY 6006 HYD P/N 180002

NO	QTY	PART NO	DESCRIPTION	NO	QTY	PART NO	DESCRIPTION
1	1	233403	FEDESTAL	21	2	201520	BEARING (RET. DFLT)
2	1	234400	BASE ASSEMBLY	22	1	409900	BOOM DRUM
3	2	300002	ACTUATOR ASSEMBLY	23	2	002900	1/4-20NC X 3/8 SCREW
4	1	315302	TURNER ASSEMBLY	24	2	101024	1/4 X 1/4 X 4 HEX STOCK
5	1	676106	PANEL ASSEMBLY	25	4	307100	SPRIG LOCK RETAINING RING
6	1	305600	RELAY GUARD	26	4	400500	BEARING
7	1	400900	HOIST DRUM	27	1	241136	LOAD LIMIT SWITCH
8	1	001302	W-32 X 1/2 RD HO MACH SCREW	28	1	013301	5/8-18 X 1/2 CAPSCREW GR B
9	6	019700	W-32 X 1/2 RD HO MACH SCREW	29	1	018100	5/8-18 HALF LOCK NUT
10	3	306600	SHIELD	30	2	330009	HINGE PIN
11	6	005900	1/4-20NC NUT (AS SPACER)	31	2	239000	GREASE ZERK
12	1	002900	1/4-20NC X 3/8 SCREW	32	1	639700	BOOM LIMIT SWITCH
13	12	021001	3/8-16UNC X 1/2 CAPSCREW	33	4	013000	7/8NF X 4 CAPSCREW GR 3
14	2	008701	3/8-16UNC X 1/2 CAPSCREW	34	4	019500	7/8NF HEX NUT
15	1	302203	GEAR GUARD-LOWER	35	4	019500	7/8NF HEX NUT
16	9	004800	HO SELF TAPPING SHEET METAL SCW	36	1	662202	1/8 LOCK WASHER
17	8	002603	SCREW HEX HD S.T. 12 X 1/2	37	3	308201	BRAKE ASSEMBLY
18	1	017200	3/8-24 THIN SELF-LOCKING NUT	38	1	330607	HYDRAULIC PUMP
19	1	009900	3/8-24NF X 3/2 CAPSCREW	39	1	REF	BOOM (10-18FT EXT) OPTIONAL
20	1	201903	ROLLER ASSEMBLY	40	1	REF	BOOM (14-20FT EXT) OPTIONAL
41	6	020600	WASHER, SPLK 5/16 NC CP	41	6	020600	WASHER, SPLK 5/16 NC CP
42	4	007200	SCREW, HEX 5/16 NC CP	42	4	007200	SCREW, HEX 5/16 NC CP
43	4	020901	WASHER, FLAT 5/16	43	4	020901	WASHER, FLAT 5/16
44	4	016500	NUT, HEX 5/16 NCCP	44	4	016500	NUT, HEX 5/16 NCCP
45	2	008701	SCREW, HEX 3/8 X 1 NC 03	45	2	008701	SCREW, HEX 3/8 X 1 NC 03
46	1	200876	ADAPTER, O-RING	46	1	200876	ADAPTER, O-RING
47	1	243152	HYDRAULIC HOSE	47	1	243152	HYDRAULIC HOSE
48	1	241188	BRACKET, TURNER	48	1	241188	BRACKET, TURNER
49	2	017301	NUT, HEX-1/2 3/8 NCCP 03	49	2	017301	NUT, HEX-1/2 3/8 NCCP 03
50	2	005900	SCREW, HEX HD 1/4 X 3/4 NC 03	50	2	005900	SCREW, HEX HD 1/4 X 3/4 NC 03
51	11	020500	WASHER, SPLK 1/4 CP	51	11	020500	WASHER, SPLK 1/4 CP
52	3	013500	NUT, HEX 1/4 NCCP 03	52	3	013500	NUT, HEX 1/4 NCCP 03
53	1	643200	TRUCK CABLE TIE	53	1	643200	TRUCK CABLE TIE
54	1	304500	WASHER, FLAT 1/2	54	1	304500	WASHER, FLAT 1/2
55	1	480780	PLATE, HOSE PROTECTOR	55	1	480780	PLATE, HOSE PROTECTOR
56	1	480780	PLATE, HOSE PROTECTOR	56	1	480780	PLATE, HOSE PROTECTOR
57	2	007801	SCREW, HEX 1/2 X 3/4 NC 03	57	2	007801	SCREW, HEX 1/2 X 3/4 NC 03
58	1	243180	ELL, 90P W/8 O-RING JIC	58	1	243180	ELL, 90P W/8 O-RING JIC
59	2	241175	ELL, 90P W/8 O-RING JIC	59	2	241175	ELL, 90P W/8 O-RING JIC
60	2	241170	ADAPTER, BLK HD 5/16-18 JIC	60	2	241170	ADAPTER, BLK HD 5/16-18 JIC
61	2	007808	SCREW, HEX HD 5/16 X 1/2 NF 03	61	2	007808	SCREW, HEX HD 5/16 X 1/2 NF 03
62	1	002900	SCREW, SET-CUP 1/4 X 3/8 NC	62	1	002900	SCREW, SET-CUP 1/4 X 3/8 NC
63	1	640700	SWITCH, RET-LOCK	63	1	640700	SWITCH, RET-LOCK
64	2	008900	SCREW, HEX HD 3/8 X 1 1/4 NC	64	2	008900	SCREW, HEX HD 3/8 X 1 1/4 NC
65	8	021200	WASHER, FLAT 3/8 SAE	65	8	021200	WASHER, FLAT 3/8 SAE
66	3	005601	SCREW, HEX HD 1/4 X 1 NCCP 03	66	3	005601	SCREW, HEX HD 1/4 X 1 NCCP 03
67	1	002100	SCREW, HEX HD 1/4 X 1 NCCP 03	67	1	002100	SCREW, HEX HD 1/4 X 1 NCCP 03
68	12	003900	NUT, HEX HD 1/4 03	68	12	003900	NUT, HEX HD 1/4 03
69	3	306400	SCREW, HEX 3/8 X 3/4 CP	69	3	306400	SCREW, HEX 3/8 X 3/4 CP
70	4	008400	SCREW, HEX 3/8 X 3/4 CP	70	4	008400	SCREW, HEX 3/8 X 3/4 CP
71	4	330372	NUT, HEX 3/8 NCCP	71	4	330372	NUT, HEX 3/8 NCCP
72	1	330612	HYD HOSE ASSEMBLY	72	1	330612	HYD HOSE ASSEMBLY
73	1	302004	SOLENOID VALVE	73	1	302004	SOLENOID VALVE
74	1	330613	CONDUCTOR ASSEMBLY	74	1	330613	CONDUCTOR ASSEMBLY

NOTE:
TORQUE MOUNTING
BOLTS AT 330 FT LBS
UPON ASSEMBLY.

8/88

AUTO CRANE COMPANY

GENERAL ASSEMBLY - 6006 - HYD

P/N 180002

REV. 1

DATE: 11/15/88

BY: J. W. J.

CHECKED: J. W. J.

APPROVED: J. W. J.

SCALE: 1/2" = 1'-0"

SHEET 1 OF 1

BASE ASSEMBLY & MAINTENANCE

6006

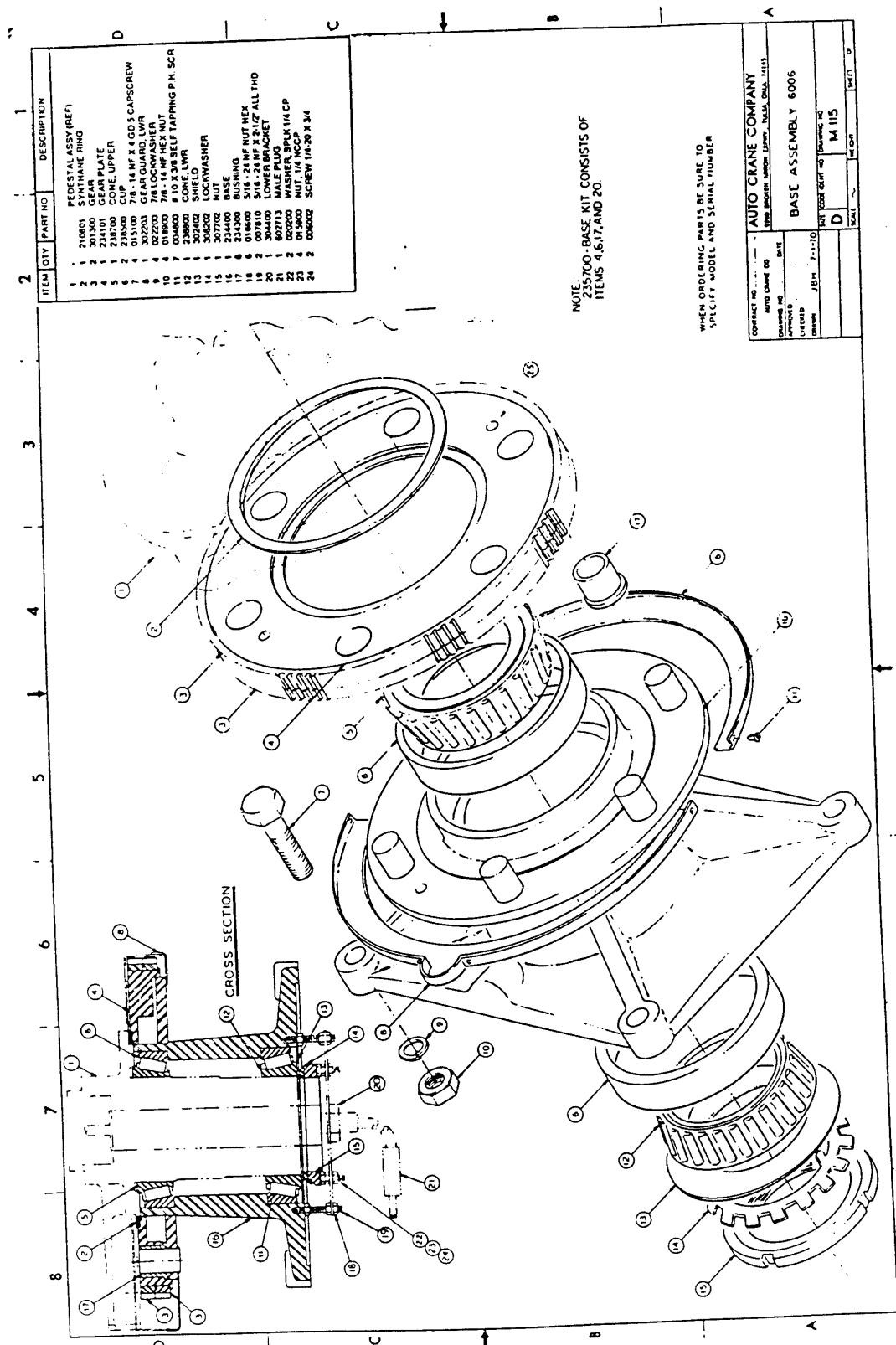

ITEM	QTY	PART NO	DESCRIPTION
1	1	210801	PEDESTAL ASSY (REF)
2	2	301300	SYNTHANE RING
3	1	231001	GEAR
4	1	231101	GEAR PLATE
5	1	238700	CONE, UPPER
6	4	015100	7/8 - 14 MF X 4 GD 3 CAPSCREW
7	4	302203	GEAR GUARD, LWR
8	4	022200	7/8 LOCKWASHER
9	4	022200	7/8 LOCKWASHER
10	1	022200	7/8 LOCKWASHER
11	1	022200	7/8 LOCKWASHER
12	1	238600	CONE, LWR
13	1	302402	SHIELD
14	1	305202	WASHER
15	1	305202	WASHER
16	1	234400	BASE
17	6	234300	BUSHING
18	6	018600	5/16 - 24 MF NUT, HEX
19	6	018600	5/16 - 24 MF X 3/16Z ALL THD
20	1	304400	LOWER BRACKET
21	1	602713	MALE PLUG
22	2	020200	WASHER, 3/4 X 1 1/4 CP
23	2	020200	WASHER, 3/4 X 1 1/4 CP
24	2	058602	SCREW 1/4-20 X 3/4

NOTE:
235700-BASE KIT CONSISTS OF
ITEMS 4,6,17, AND 20.

WHEN ORDERING PARTS BE SURE TO
SPECIFY MODEL AND SERIAL NUMBER

CONTRACT NO.		AUTO CRANE COMPANY	
Auto Crane ID	DATE	2008-10-10	
APPROVED	DATE	BASE ASSEMBLY 6006	
DESIGNED	DATE	M 115	
DRAWN	DATE	M 115	
SCALE	1:1	SHEET 02	

BASE ASSEMBLY & MAINTENANCE

6006

MAINTENANCE OF BASE ASSEMBLY MODEL 6006 SERIES

The features incorporated in the Model 6006 Series base permits the increased rating of the unit. Some of these features are: The heavier pedestal quill (Item 1) which permits the maximum spread between the bearings. The double ring gears (Item 3) provide for rotating the boom with heavier loads. An added feature is the floating gear plate (Item 4) which provides perfect alignment of the ring gears with the turn drive pinion. The gear plate is mounted on 6 resilient bushings (Item 17). The bushings absorb shock loading on the gear teeth and provide a cushioned start and stop of the swinging boom.

1. PREPARATION FOR DISASSEMBLY:

To disassemble the base, some preparation must be made: Disconnect the coupling (21) from the power source, remove turn actuator, remove unit batter. Remove crane from its mounting by removing four hold-down bolts (7) and lift the crane vertically to clear the swivel assembly (20). One method is to block up under the boom near the hinge point and tilt the unit over on the bottom to a horizontal position. Remove lower gear guard (8) by removing seven self-tapping screws (Item 11). Next (4) 5/8 N.C.X. 1 1/2 capscrews (Item 25, cross sectional view) should be installed and pulled down tight. These capscrews will hold the compression on the shoulders of bushing (17) and hold the gear plate in proper relation until reinstalled.

2. REMOVE SWIVEL ASSEMBLY:

Remove nut (18). Swivel bracket (20). Remove stud bolts (19) to avoid damage to studs.

3. REMOVE BEARING NUT:

One tongue of lockwasher (14) is bent into one of the key slots in the nut (15). Bend Tongue out of key slot using screwdriver or drive bar. Remove nut using spanner wrench or drive bar.

The base (16) is now held to the quill by the cone of bearing (12). Remove base from quill using puller or drive bar. Cone bearing (12) will come off with base. Thrust ring (2) can now be removed.

4. GEAR REMOVAL:

If the base was removed in order to replace the gear rings (3), no further disassembly need be done. The gears have been heated and installed on the gear plate (4) and then tackwelded in place.

Remove tackwelds with a chisel or cutting torch. A grinder could also be used. The gears can be cut with a cutting torch holding the torch at a tangent to the gears.

5. GEAR INSTALLATION:

Check to be sure all burrs have been removed from the gear mounting surface of the gear plate. Since the gear is laminat-

ed, consisting of two gear rings, the installation procedure is as follows:

Heat one ring with a torch or in an oven to around 500°F using heavy gloves and install the first ring down against shoulder of gear plate. Allow to cool. Heat second ring.

(NOTE: It is important that the gear rings be evenly heated around the total circumference.) Install top ring down against lower rings.

It is important that the gear teeth are in alignment. This alignment can be accomplished by using a blunt chisel which has point slightly thicker than the pinion teeth. Drive the chisel lightly between the teeth of the two gear rings at different points around the gears while the upper ring cools. Continue checking and aligning teeth until the gear shrinks securely onto the gear plate. Tackweld each ring to the gear plate in at least four places:

NOTE: Unless the customer has the facilities to install the gear rings as outlined above, it is recommended that he order the gear plate with the gear rings factory installed. If the use gear and plate assembly is returned, an exchange price adjustment will be made.

BEARING REMOVAL:

If the base is being disassembled in order to replace the pedestal assembly (Item 1), the bearing cone (Item 5) should be removed from the pedestal quill. This can be done by using a pry bar. If the bearings are to be replaced, the cone (5) should be removed as well as the bearing cups (Item 6). The cups can be removed by using a drive bar through the open ends of the base.

REASSEMBLE, BEARING INSTALLATION:

To install bearing cone (5) heat to around 200°F. Be sure the bearing cup is installed up against upper shoulder. Install bearing cups (6) in base; be sure they are all of the way in, up against the shoulders in the base. Lubricate upper cone (5) with grease gun grease, filling spaces between rollers. Install base on pedestal quill. Lubricate and install lower cone (12). Install grease shield (13), lock washer (14) and nut (15). Tighten nut (15) until it requires considerable effort to rotate the base on the quill.

Bend one of the tongues on lock washer (14) into one of the slots of the nut (15). Install swivel connection. The unit can now be raised and hold-down bolts (7) installed. Reinstall turn actuator

WHEN ORDERING PARTS BE SURE TO SPECIFY MODEL AND SERIAL NUMBER.

17' BOOM ASSEMBLY 6006

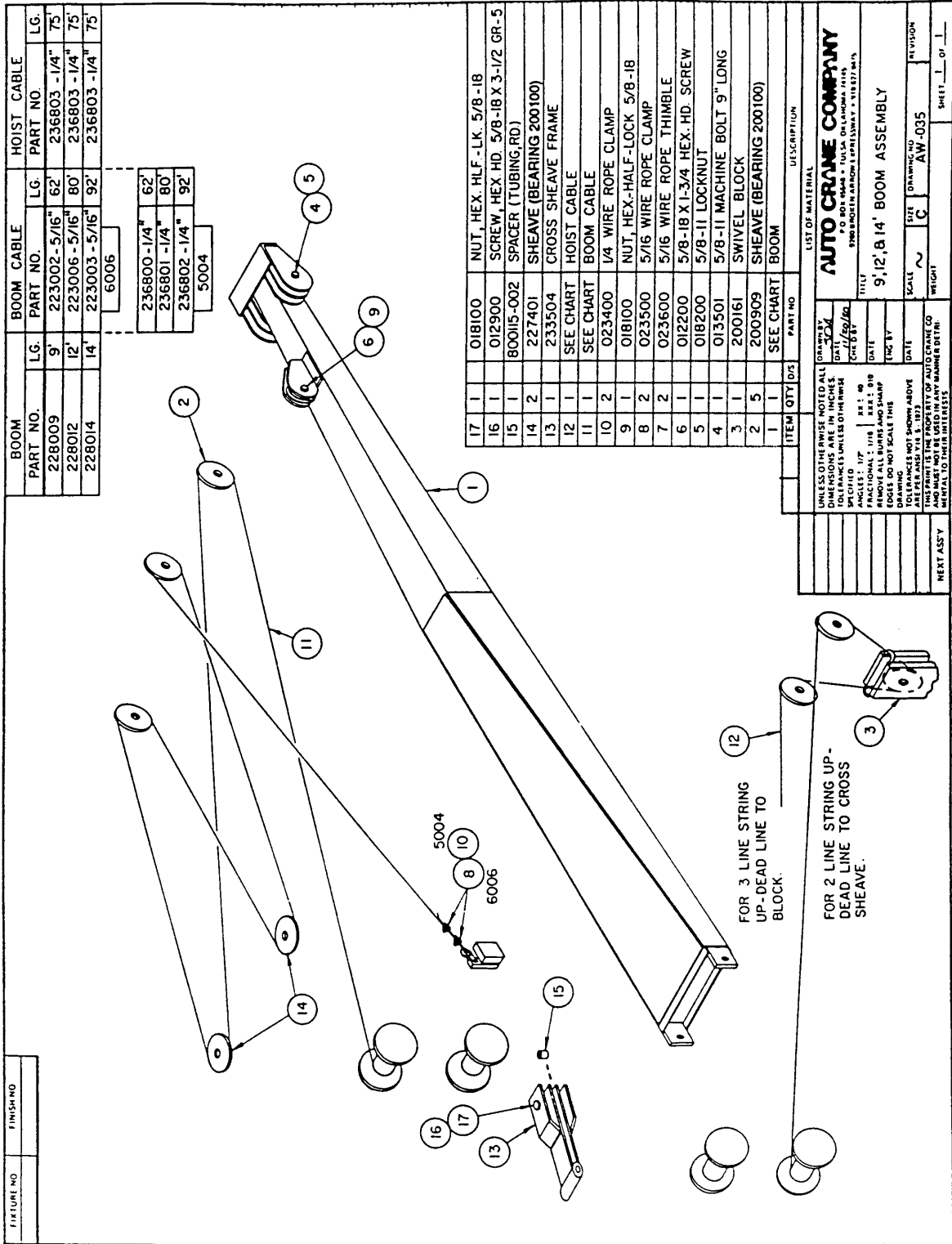

LIST OF MATERIAL	
ITEM	DESCRIPTION
17	NUT, HEX. HLF. LK. 5/8 - 18
16	SCREW, HEX HD. 5/8 - 18 X 3-1/2 GR-5
15	SPACER (TUBING, RD)
14	SHEAVE (BEARING 200100)
13	CROSS SHEAVE FRAME
12	HOIST CABLE
11	BOOM CABLE
10	1/4 WIRE ROPE CLAMP
9	NUT, HEX-HALF-LOCK 5/8 - 18
8	5/16 WIRE ROPE CLAMP
7	5/16 WIRE ROPE THIMBLE
6	5/8 - 18 X 1-3/4 HEX. HD. SCREW
5	5/8 - 11 LOCKNUT
4	5/8 - 11 MACHINE BOLT 9" LONG
3	SWIVEL BLOCK
2	SHEAVE (BEARING 200100)
1	BOOM

UNLESS OTHERWISE NOTED ALL DIMENSIONS ARE IN INCHES. DIMENSIONS IN PARENTHESES ARE FOR REFERENCE ONLY.

ANGLES: 1/4" = 1/4" 1/2" = 1/2" 3/4" = 3/4" 1" = 1" 1 1/2" = 1 1/2" 2" = 2" 3" = 3" 4" = 4" 6" = 6" 8" = 8" 10" = 10" 12" = 12" 14" = 14" 16" = 16" 18" = 18" 20" = 20" 24" = 24" 30" = 30" 36" = 36" 48" = 48" 60" = 60" 72" = 72" 96" = 96" 120" = 120"

REMOVE ALL BURRS AND SHARP EDGES DO NOT SCALE THIS DRAWING

THIS PRINT IS THE PROPERTY OF AUTO CRANE CO. IT IS TO BE KEPT IN THE COMPANY'S POSSESSION AND NOT TO BE LOANED, REPRODUCED, COPIED, OR IN ANY MANNER DISSEMINATED TO THEIR INTEREST.

DATE: 3/24/80
 DRAWN BY: J. J. JONES
 CHECKED BY: J. J. JONES
 TITLE: 9', 12', 14', 17' BOOM ASSEMBLY
 SCALE: AS SHOWN
 REVISION: AW-035
 SHEET: 1 OF 1

20' BOOM ASSEMBLY 6006

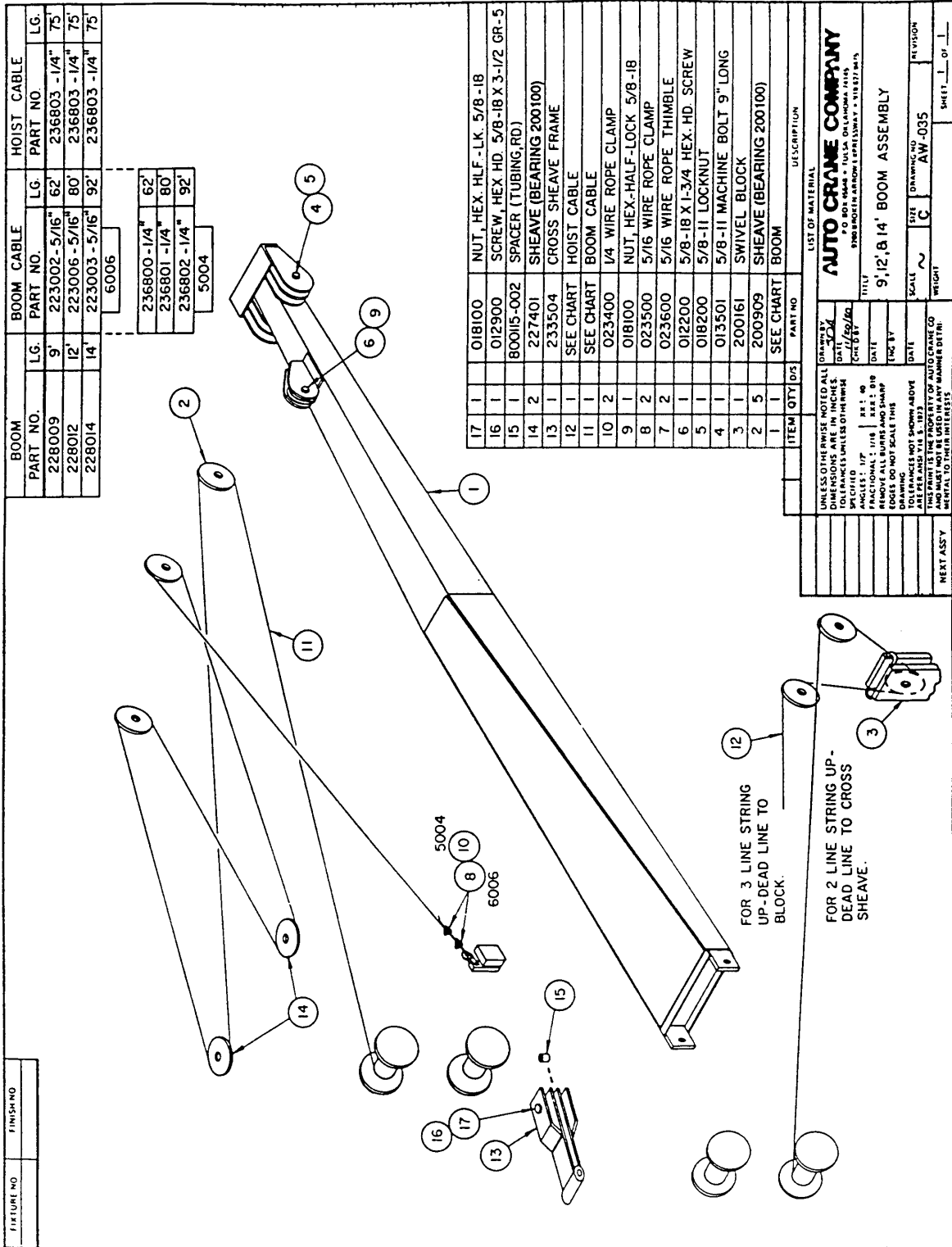

10'-16' EXTENDABLE BOOM P/N 241197

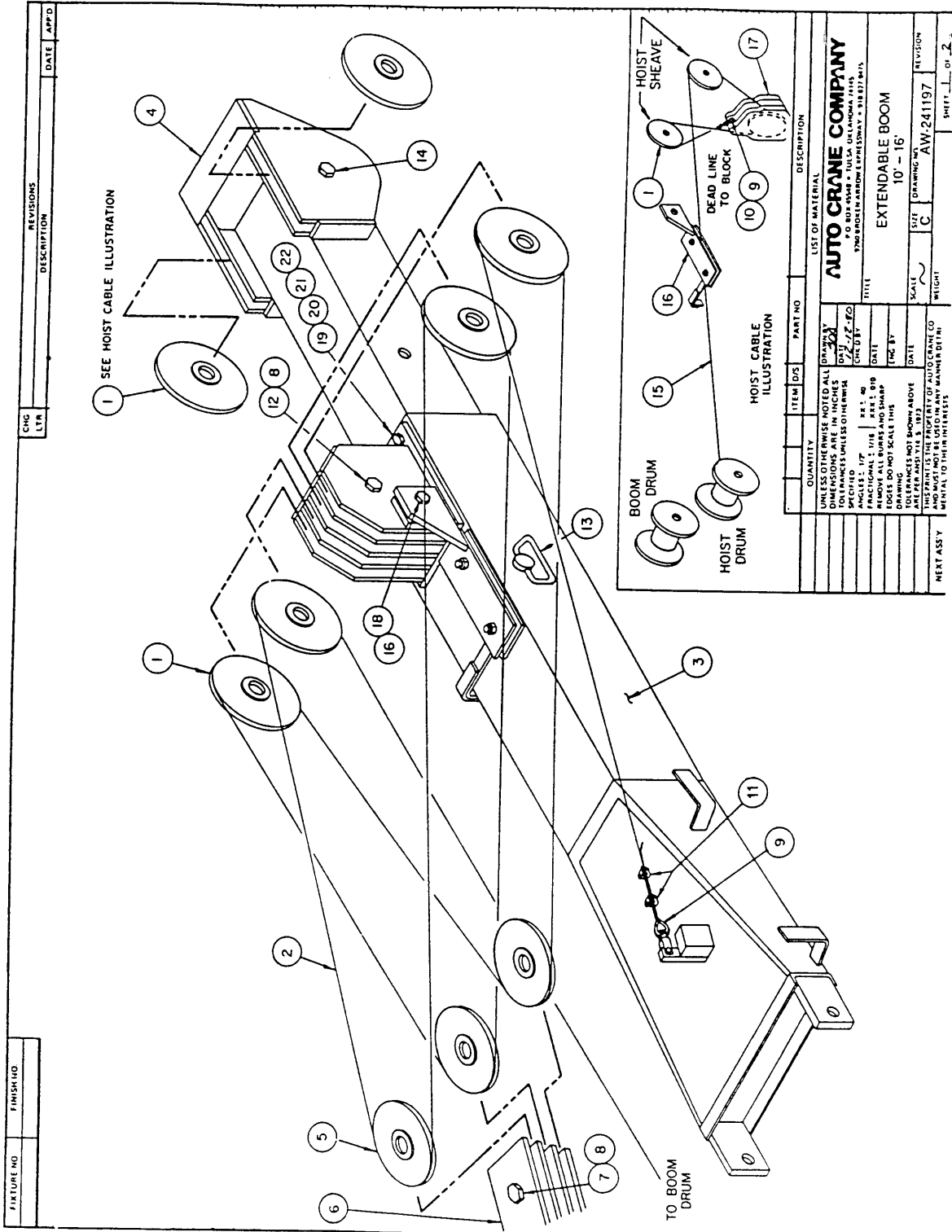

10'-16' EXTENDABLE BOOM

P/N 241197

ITEM	QTY.	PART NO.	DESCRIPTION
1	6	240241	SHEAVE (BEARING 200100)
2	88'	800530	CABLE 5/16"
3	1	241196	LOWER BOOM
4	1	240201	BOOM, UPPER ASS'Y
5	3	227401	SHEAVE (BEARING 200100)
6	1	233504	CROSS SHEAVE
7	1	012900	SCREW 5/8 - 18 X 3 1/2 GR.5
8	2	018100	NUT HX. HLF. LK. 5/8 - 18
9	2	023600	5/16 WIRE ROPE THIMBLE
10	2	023400	1/4 WIRE ROPE CLAMP
11	2	023500	5/16 WIRE ROPE CLAMP
12	1	013504	SCREW HX. 5/8 - 18 X 5 GR.5
13	1	240246	PIN ASSEMBLY
14	2	012501	SCREW HX. 5/8 - 18 X 2 1/2 GR.5
15	88'	800529	CABLE 1/4"
16	1	240263	CABLE GUIDE ASSEMBLY
17	1	360602	SWIVEL BLOCK
18	1	012203	SCREW HX. 5/8 - 18 X 1 1/4 GR.5
19	1	240224	PAD LOCKING
20	2	007400	SCREW HX. 5/16 - 18 X 1" GR.5
21	2	020600	WASHER, SP. LK. 5/16
22	2	020901	WASHER, FLAT 5/16

NOTE:

1. 10' - 16' BOOM REQUIRES 360602 TRAVELING BLOCK
2. TO CONVERT A FIXED BOOM TO A 10' - 16' EXTENDABLE BOOM, USE CONVERSION KIT PART NUMBER 241197-001

14'-20' EXTENDABLE BOOM

P/N 240200

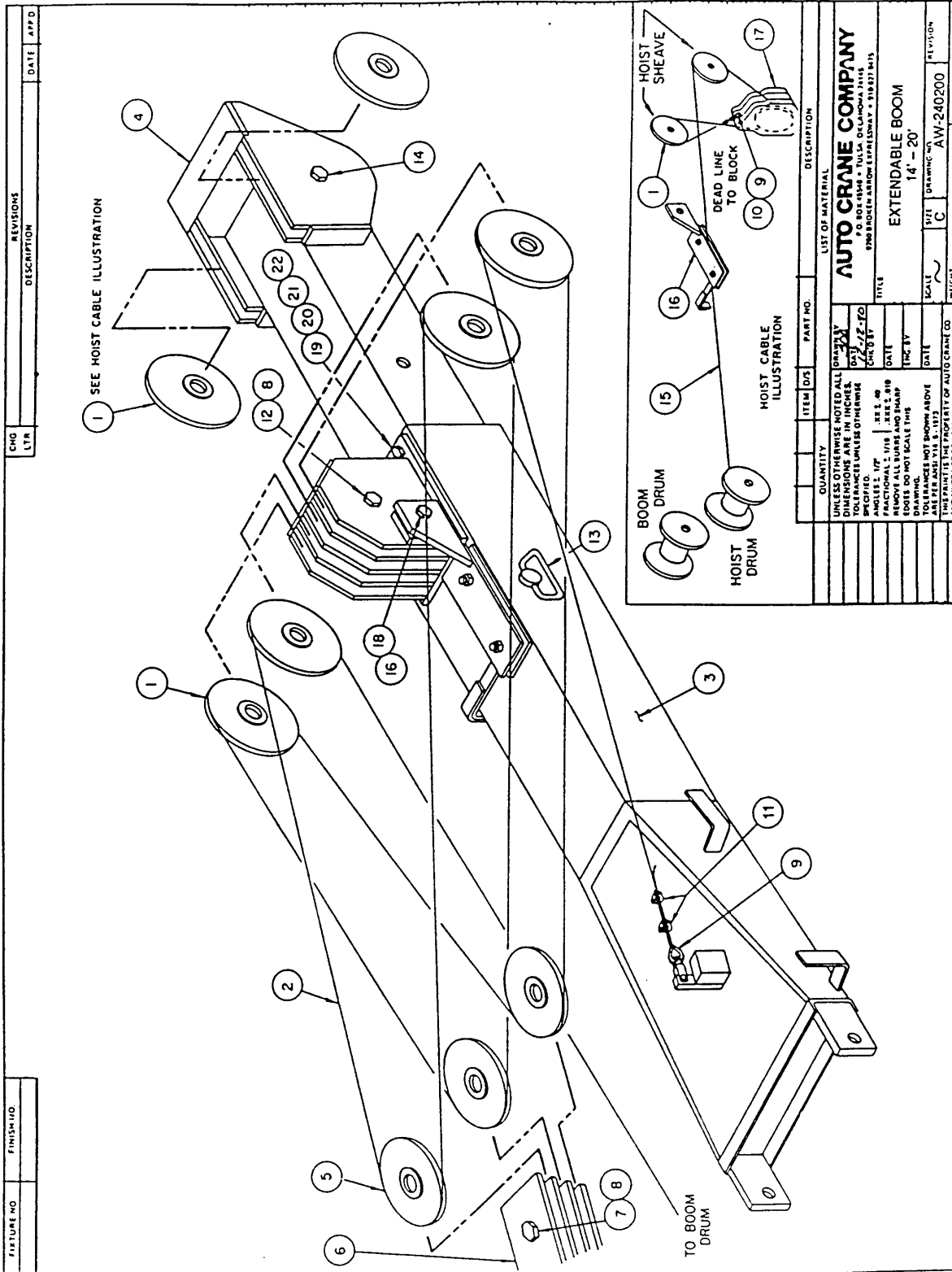

CMG	REVISIONS	DATE	APPD
LTR	DESCRIPTION		

FINISH NO.	FINISH ID.

QUANTITY	ITEM NO.	PART NO.	DESCRIPTION
LIST OF MATERIAL			
AUTO CRANE COMPANY			
P.O. BOX 1444 • TULSA, OKLAHOMA 74101			
PINEBROOK ARROW STRAIGHTWAY • 318 231 8415			
TITLE			
EXTENDABLE BOOM			
14' - 20'			
SCALE			
C			
DRAWING NO.			
AW-240200			
REVISION			
1			

14'-20' EXTENDABLE BOOM

P/N 240200

ITEM	QTY.	PART NO.	DESCRIPTION
1	6	240241	SHEAVE (BEARING 200100)
2	120'	800530	CABLE 5/16"
3	1	240202	LOWER BOOM
4	1	240201	BOOM, UPPER ASS'Y
5	3	227401	SHEAVE (BEARING 200100)
6	1	233504	CROSS SHEAVE
7	1	012900	SCREW 5/8 - 18 X 3 1/2 GR.5
8	2	018100	NUT HX. HLF. LK. 5/8 - 18
9	2	023600	5/16 WIRE ROPE THIMBLE
10	2	023400	1/4 WIRE ROPE CLAMP
11	2	023500	5/16 WIRE ROPE CLAMP
12	1	013504	SCREW HX. 5/8 - 18 X 5 GR.5
13	1	240246	PIN ASSEMBLY
14	2	012501	SCREW HX. 5/8 - 18 X 2 1/2 GR.5
15	92'	800529	CABLE 1/4"
16	1	240263	CABLE GUIDE ASSEMBLY
17	1	200161	SWIVEL BLOCK
18	1	012203	SCREW HX. 5/8 - 18 X 1 1/4 GR.5
19	1	240224	PAD LOCKING
20	2	007400	SCREW HX. 5/16 - 18 X 1" GR.5
21	2	020600	WASHER, SP. LK. 5/16
22	2	020901	WASHER, FLAT 5/16

NOTES:

1. TO CONVERT A FIXED BOOM TO A 14' - 20' EXTENDABLE BOOM, USE CONVERSION KIT PART NUMBER 240200-001

10'-16' EXTENDABLE BOOM HYD

P/N 240258

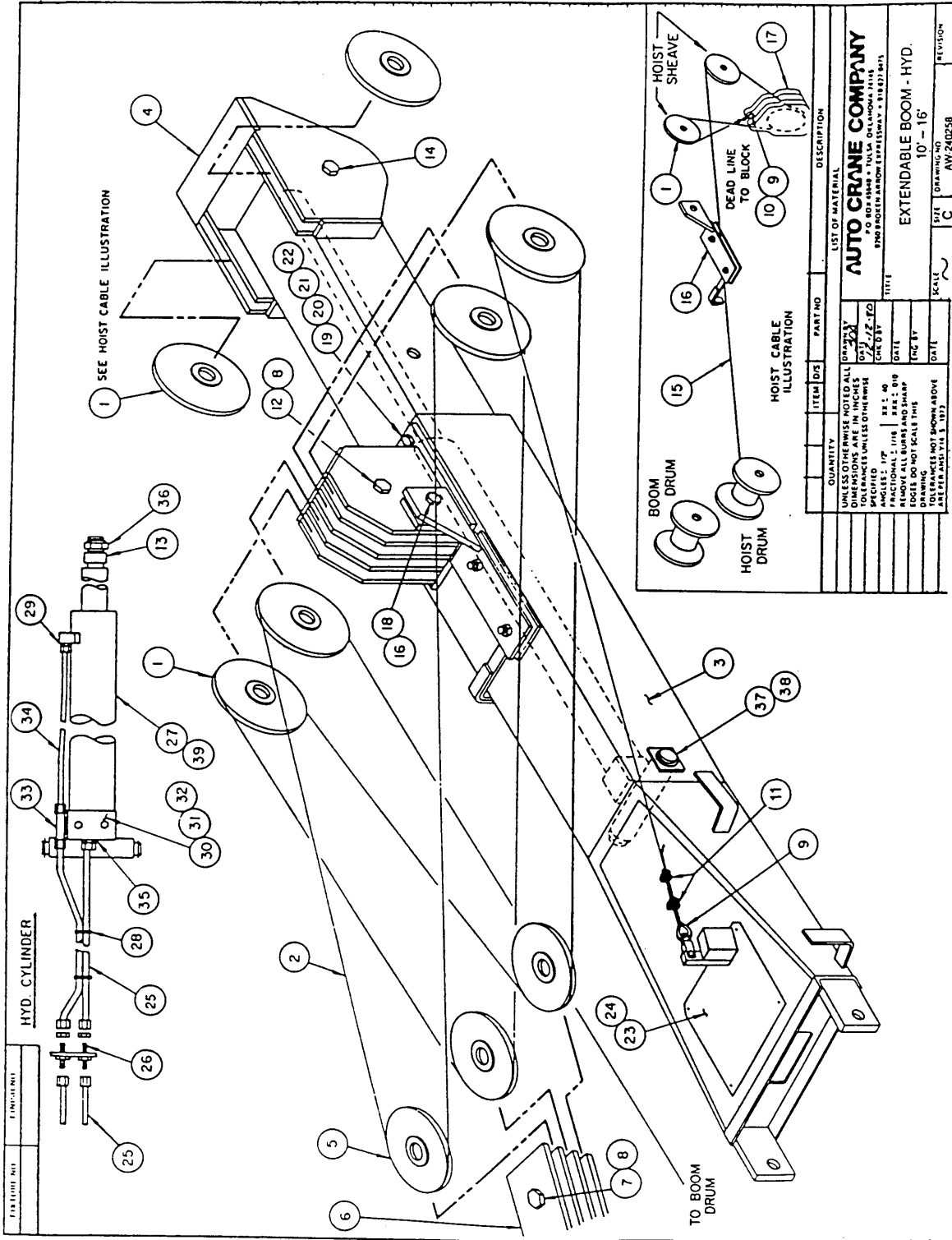

10'-16' EXTENDABLE BOOM HYD

P/N 240258

ITEM	QTY.	PART NO.	DESCRIPTION
1	6	240241	SHEAVE (BEARING 200100)
2	88'	800530	CABLE, BOOM 5/16"
3	1	240262	LOWER BOOM
4	1	330110	BOOM, UPPER
5	3	227401	SHEAVE (BEARING 200100)
6	1	233504	CROSS SHEAVE
7	1	012900	SCREW 5/18 - 18 X 3 1/2 GR.5
8	2	018100	NUT, HX HLF. LK. 5/8 - 18
9	2	023600	5/16 WIRE ROPE THIMBLE
10	2	023400	1/4 WIRE ROPE CLAMP
11	2	023500	5/16 WIRE ROPE CLAMP
12	1	013504	SCREW HX. 5/8 - 18 X 5 GR.5
13	1	800067-001	SPACER
14	2	012501	SCREW HX. 5/8 - 18 X 2 1/2 GR.5
15	88'	800529	CABLE HOIST 1/4"
16	1	200263	CABLE GUIDE ASSEMBLY
17	1	200161	SWIVEL BLOCK
18	1	012203	SCREW HX. 5/8 - 18 X 1 1/4 GR.5
19	1	240224	PAD, LOCKING
20	2	007400	SCREW HX. 5/16 - 18 X 1" GR.5
21	2	020600	WASHER, SP. LK. 5/16
22	2	020901	WASHER, FLAT 5/16
23	1	240242	COVER, ACCESS
24	4	002006	SCREW HX. SL. S.T. # 10 X 1/2
25	4	241173	HOSE ASS'Y HYD.
26	2	241170	ADAPTER, BULKHEAD 9/16 - 18 37°
27	1	241166	CYLINDER, HYD. WITH HARDWARE
28	4	634400	TIE CABLE
29	1	360042	ADAPTER 9/16 - 18 O-RING
30	2	020200	WASHER SP. LK. 1/4
31	2	005800	SCREW HX. HD. 1/4 - 20 X 1 1/2 GR.5
32	1	330412	HOLDING VALVE
33	1	241168	TEE, 9/16 37° RUN, 9/16 - 18 O-RING
34	1	330087	LINE ASS'Y HYD.
35	1	200876	ADAPTER 9/16 - 18 JIC/ 9/16 - 18 ORB
36	1	019106	NUT HX. LK. 1" N.F. CP
37	1	241214	PIN
38	1	241213	RETAINING RING
39	1	330601	SEAL KIT (FOR CYLINDER 241166)

NOTE:

1. TO CONVERT A 10' - 16' MANUAL EXTENSION BOOM TO A 10' - 16' POWER EXTENSION, ORDER KIT NUMBER 240281 (FOR 12/24 VOLT UNITS), OR KIT 330536 (FOR 220/24 110/24 VOLT UNITS).

14'-20' EXTENDABLE BOOM HYD

P/N 240257

ITEM	QTY.	PART NO.	DESCRIPTION
1	6	240241	SHEAVE (BEARING 200100)
2	120'	800530	CABLE, BOOM 5/16"
3	1	240259	LOWER BOOM
4	1	330110	BOOM, UPPER
5	3	227401	SHEAVE (BEARING 200100)
6	1	233504	CROSS SHEAVE
7	1	012900	SCREW 5/18 - 18 X 3 1/2 GR.5
8	2	018100	NUT, HX HLF. LK. 5/8 - 18
9	2	023600	5/16 WIRE ROPE THIMBLE
10	2	023400	1/4 WIRE ROPE CLAMP
11	2	023500	5/16 WIRE ROPE CLAMP
12	1	013504	SCREW HX. 5/8 - 18 X 5 GR.5
13	1	800067-001	SPACER
14	2	012501	SCREW HX. 5/8 - 18 X 2 1/2 GR.5
15	92'	800529	CABLE HOIST 1/4"
16	1	200263	CABLE GUIDE ASSEMBLY
17	1	200161	SWIVEL BLOCK
18	1	012203	SCREW HX. 5/8 - 18 X 1 1/4 GR.5
19	1	240224	PAD, LOCKING
20	2	007400	SCREW HX. 5/16 - 18 X 1" GR.5
21	2	020600	WASHER, SP. LK. 5/16
22	2	020901	WASHER, FLAT 5/16
23	1	240242	COVER, ACCESS
24	4	002006	SCREW HX. SL. S.T. # 10 X 1/2
25	2	241173	HOSE ASS'Y HYD.
26	2	241170	ADAPTER, BULKHEAD 9/16 - 18, 37°
27	1	241166	CYLINDER, HYD. WITH HARDWARE
28	4	634400	TIE CABLE
29	1	360042	ADAPTER 9/16 - 18 O-RING
30	2	020200	WASHER SP. LK. 1/4
31	2	005800	SCREW HX. HD. 1/4 - 20 X 1 1/2 GR.5
32	1	330412	HOLDING VALVE
33	1	241168	TEE, 9/16 37° RUN, 9/16 - 18 O-RING
34	1	330087	LINE ASS'Y HYD.
35	1	200876	ADAPTER 9/16 - 18 JIC/ 9/16 - 18 ORB
36	1	019106	NUT HX. LK. 1" N.F. CP
37	1	241214	PIN
38	1	241213	RETAINING RING
39	1	330601	SEAL KIT (FOR CYLINDER 241166)
40	2	241172	HOSE HYD.

NOTES:

1. TO CONVERT A 14' - 20' MANUAL EXTENSION BOOM TO A 14' - 20' POWER EXTENSION BOOM ORDER KIT NUMBER 240280 (FOR 12/24 VOLT UNITS), OR KIT 330535 (FOR 220/24, 110/24 VOLT UNITS).

INSTALLATION OF CABLE CLAMP

M-124

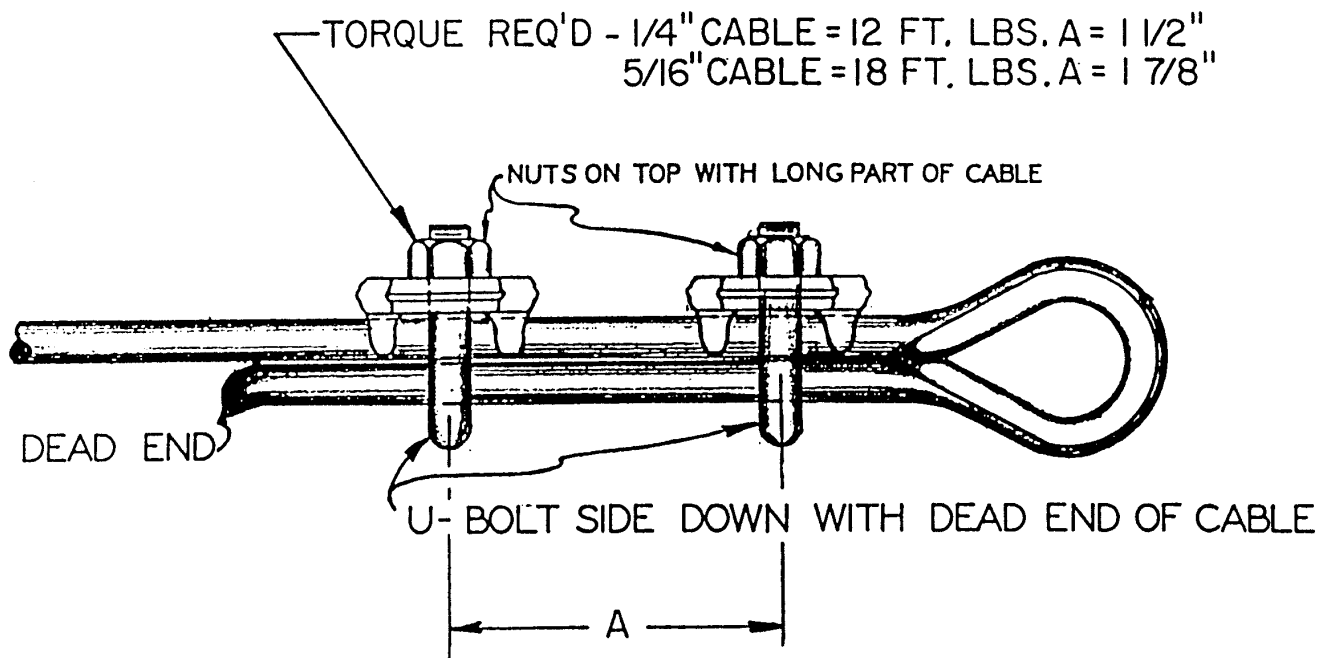

TRAVELING SWIVEL BLOCK ASSEMBLY

P/N 200161

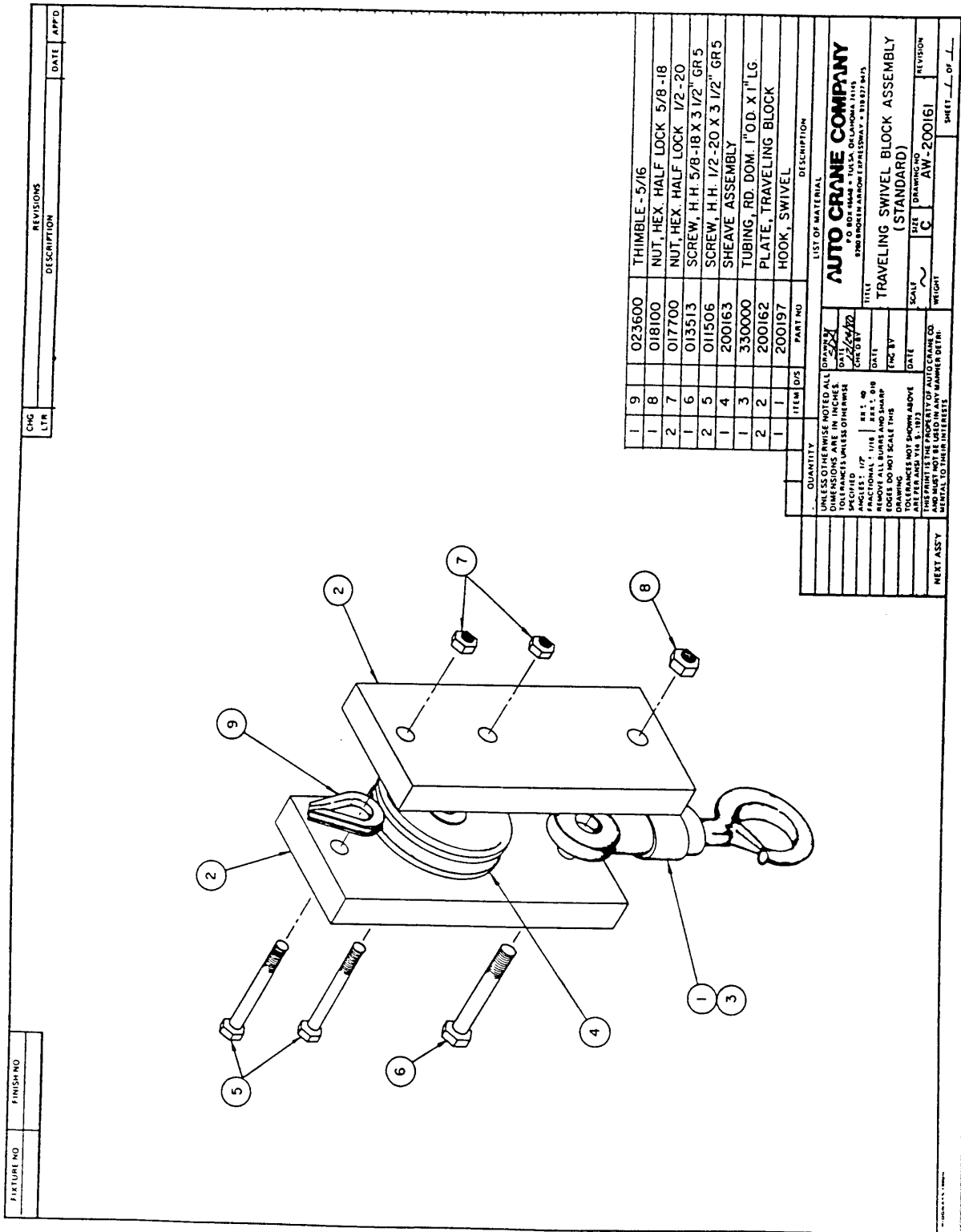

FIXTURE NO	FINISH NO	CHG LTR	REVISIONS DESCRIPTION	DATE	APPD

ITEM	QTY	DESCRIPTION
1	1	THIMBLE - 5/16
1	8	NUT, HEX. HALF LOCK 5/8-18
2	7	NUT, HEX. HALF LOCK 1/2-20
1	6	SCREW, H. H. 5/8-18 X 3 1/2" GR 5
2	5	SCREW, H. H. 1/2-20 X 3 1/2" GR 5
1	4	SHEAVE ASSEMBLY
1	3	TUBING, RD. DOM. 1" O.D. X 1" LG
2	2	PLATE, TRAVELING BLOCK
1	1	HOOK, SWIVEL

QUANTITY		LIST OF MATERIAL	
UNLESS OTHERWISE NOTED ALL DIMENSIONS ARE IN INCHES		DRAWN BY	
SPECIFIED UNLESS OTHERWISE NOTED		DATE	
ANGLES: 1/4"	REL: 40	CHECKED BY	DATE
REMOVE ALL DIMENSIONS FROM DRAWING	REL: 500	DATE	DATE
EDGES DO NOT SCALE THIS DRAWING		TITLE	
IF DIMENSIONS DO NOT SHOW ABOVE ARE RELEASD VIA 3-1073		TRAVELING SWIVEL BLOCK ASSEMBLY (STANDARD)	
THIS PRINT IS THE PROPERTY OF AUTOCRANE CO. IT IS TO BE USED IN ANY MANNER DETERMINED BY AUTOCRANE CO.		SCALE	WEIGHT
MENTAL TO THIS INTELLECT		1/4"	AW-200161
DIVISION		SHEET	
AW-200161		1 OF 1	

TRAVELING BLOCK ASSEMBLY

P/N 360602

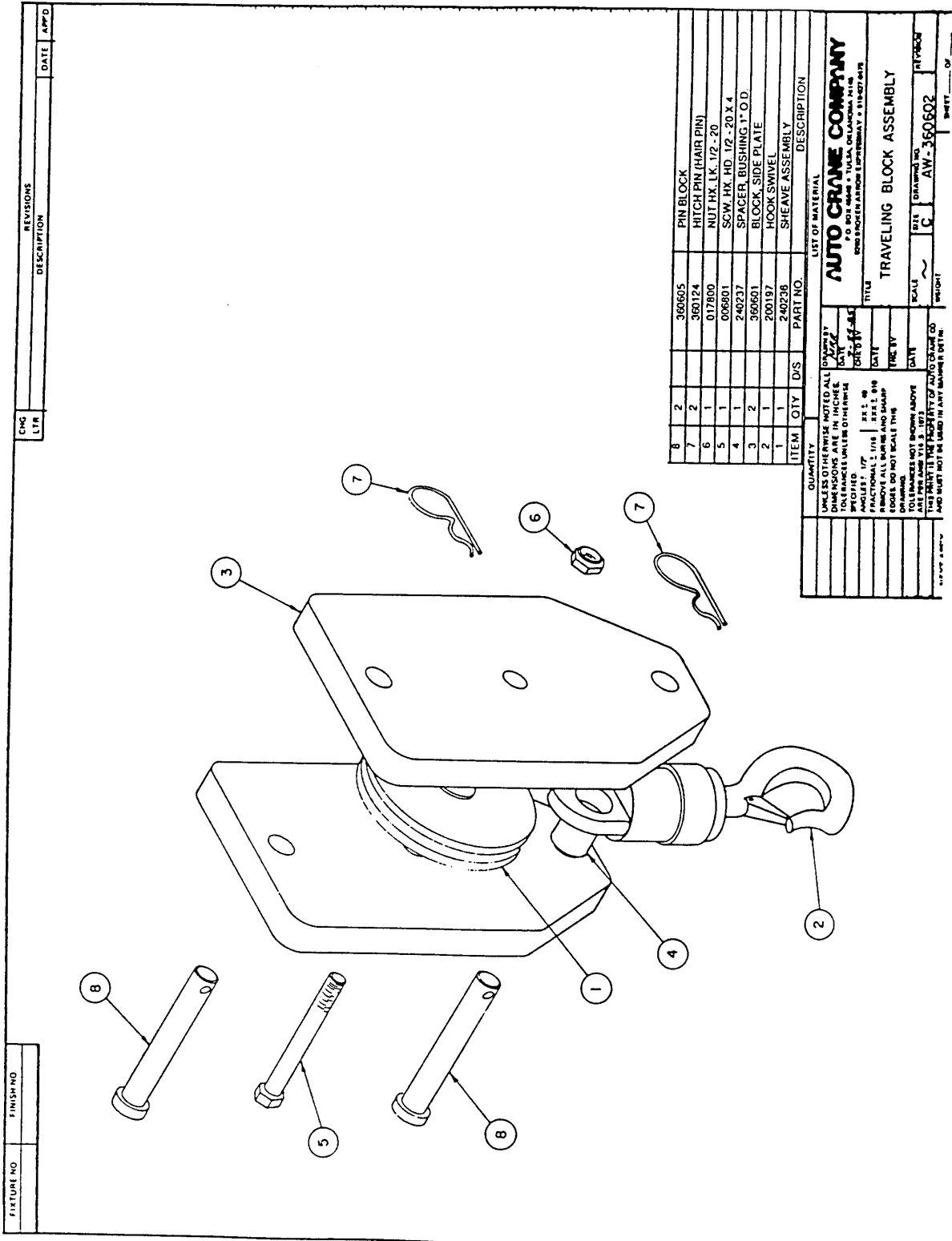

ITEM	QTY	D/S	PART NO.	DESCRIPTION
8	2		360605	PIN BLOCK
7	2		360124	HITCH PIN (HAIR PIN)
6	1		017800	NUT HK. LK. 1/2 - 20
5	1		006801	SCW. HK. HD. 1/2 - 20 X 4
4	1		240237	SPACER, BUSHING, 1" O.D.
3	2		360601	BLOCK, SIDE PLATE
2	1		200197	HOOK SWIVEL
1	1		240238	SHEAVE ASSEMBLY

QUANTITY		LIST OF MATERIAL	
UNLESS OTHERWISE NOTED ALL DIMENSIONS ARE IN INCHES			
DECIMALS ARE TO BE ROUNDED UP UNLESS OTHERWISE SPECIFIED			
ANGLES: IF NOT SPECIFIED			
FRACTIONAL SIZES: UNLESS OTHERWISE SPECIFIED			
EDGES DO NOT SCALE THIS DRAWING			
ALL DIMENSIONS WILL BE SHOWN ABOVE UNLESS OTHERWISE SPECIFIED			
THIS DRAWING IS THE PROPERTY OF AUTO CRANE CO. AND MUST NOT BE LOANED IN ANY MANNER OR REPRODUCED IN ANY MANNER			
DATE	BY	SCALE	REVISION
		C	AW-360602
DRAWN BY		CHECKED BY	
DATE		DATE	
SCALE		TITLE	
C		TRAVELING BLOCK ASSEMBLY	
AW-360602		AUTO CRANE COMPANY	
C		P.O. BOX 4444 • TULSA, OKLAHOMA 74116	
C		ENGINEERING DEPARTMENT • 318-27-6478	

FIXTURE NO.	FINISH NO.	CMC LTR.	REVISIONS	DATE	APPD.

BRAKE ASSEMBLY 12 V P/N 308201

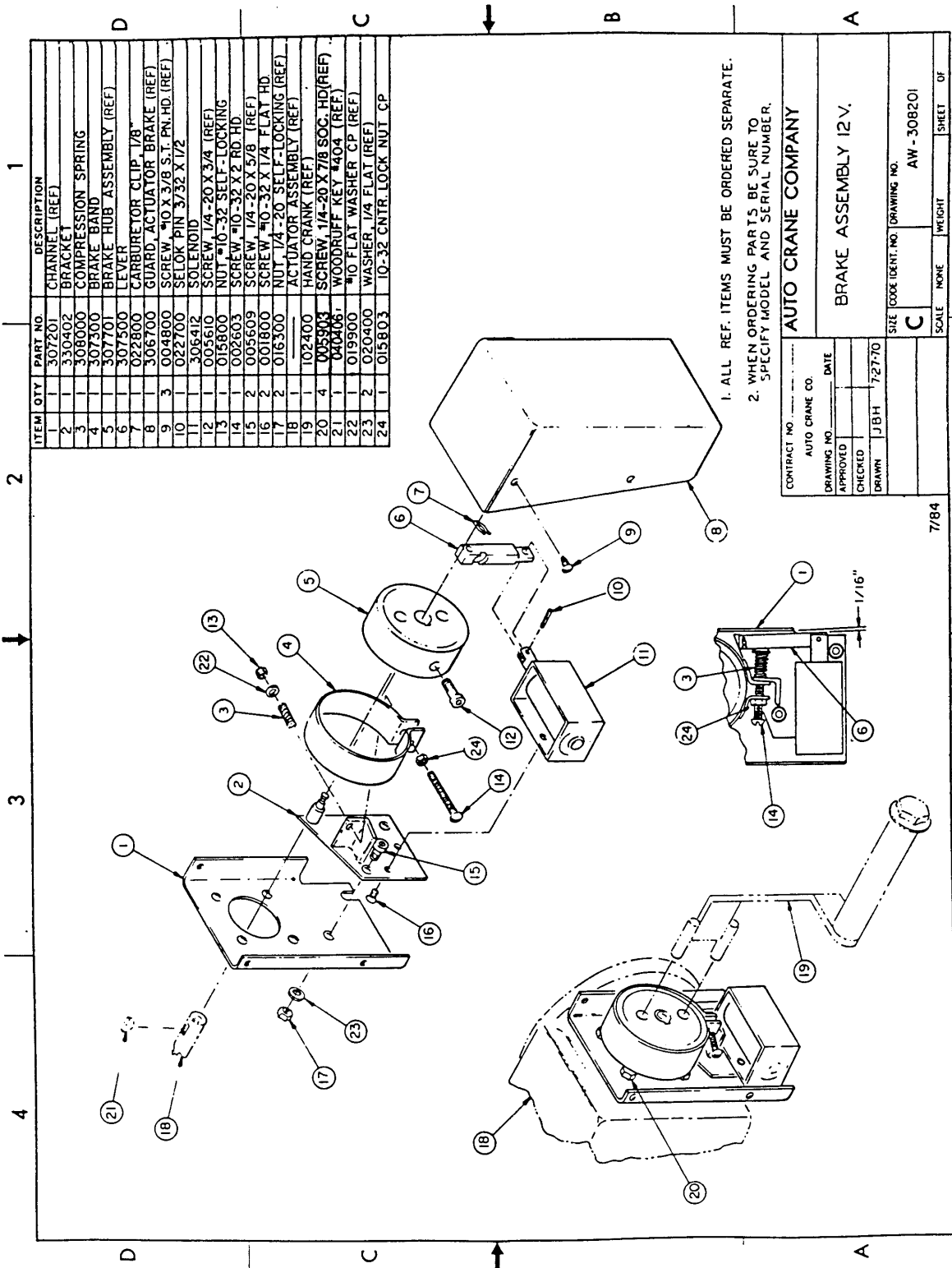

ITEM	QTY	PART NO.	DESCRIPTION
1	1	307201	CHANNEL (REF)
2	1	330402	BRACKET
3	1	308000	COMPRESSION SPRING
4	1	307300	BRAKE BAND
5	1	307701	BRAKE HUB ASSEMBLY (REF)
6	1	307500	LEVER
7	1	022800	CARBURETOR CLIP, 1/8"
8	1	306700	GUARD, ACTUATOR BRAKE (REF)
9	3	004800	SCREW, #10 X 3/8 S.T. FN.HD. (REF)
10	1	022700	SELOK PIN 3/32 X 1/2
11	1	306412	SOLENOID
12	1	003610	SCREW, 1/4-20 X 3/4 (REF)
13	1	002603	NUT, #10-32 SELF-LOCKING
14	1	005609	SCREW, 1/4-20 X 5/8 (REF)
15	2	001800	SCREW, #0-32 X 1/4 FLAT HD
16	2	001800	SCREW, #0-32 X 1/4 FLAT HD
17	2	016300	NUT, 1/4-20 SELF-LOCKING (REF)
18	1	002400	ACTUATOR ASSEMBLY (REF)
19	1	102400	HAND CRANK (REF)
20	4	005903	SCREW, 1/4-20 X 7/8 SOC. HD (REF)
21	1	040406	WOODRUFF KEY #404 (REF)
22	1	019900	#10 FLAT WASHER CP (REF)
23	2	020400	WASHER, 1/4 FLAT (REF)
24	1	015803	10-32 CNTR. LOCK NUT CP

1. ALL REF. ITEMS MUST BE ORDERED SEPARATE.
2. WHEN ORDERING PARTS BE SURE TO SPECIFY MODEL AND SERIAL NUMBER.

CONTRACT NO.		AUTO CRANE CO.	
DRAWING NO.	DATE		
APPROVED	CHECKED	DRAWN	
		JBH	7-27-70
AUTO CRANE COMPANY			
BRAKE ASSEMBLY 12V.			
SIZE	CODE IDENT. NO.	DRAWING NO.	
C		AW - 308201	
SCALE	NONE	WEIGHT	SHEET
			OF

7/84

TWECO BASE ASSEMBLY

P/N 304601

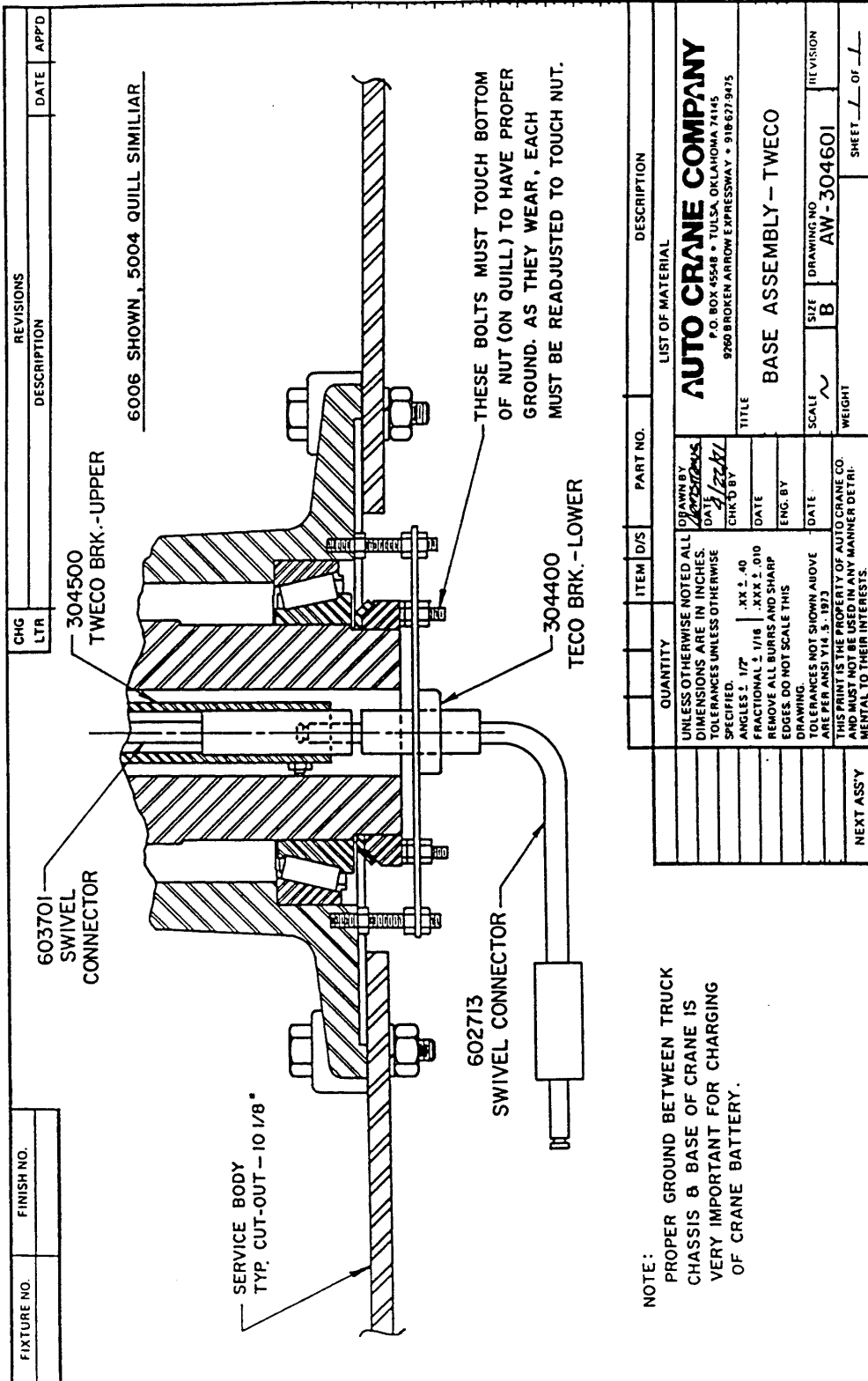

MODEL "B" ACTUATOR

6006

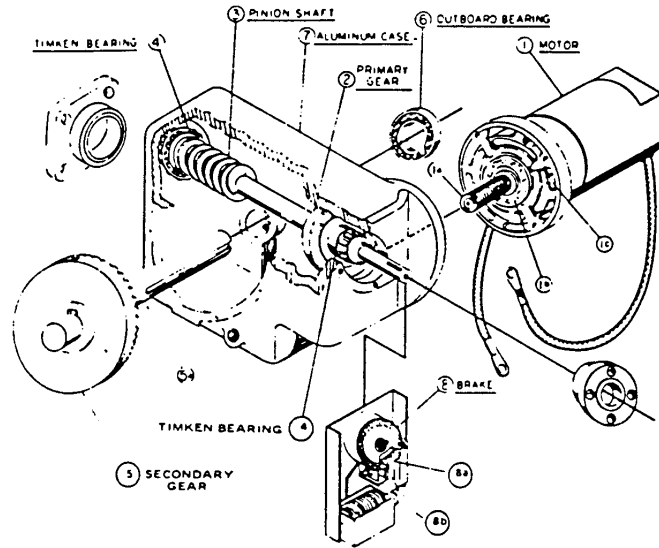

MODEL "B" ACTUATOR

Designed and Manufactured by AUTO CRANE for the most efficient operation.

OUTSTANDING FEATURES

1. The motor is the source of power. It is a universal type, reversible motor, available in up to 24-volt direct current. The direct current motor will develop 3/4 H.P. on 12-volt direct current at 5000 RPM (8000 RPM no load speed), or 1-1/2 H.P. on 24-volt direct current at 10,500 RPM (16,000 RPM no load speed).

The primary gear pinion (1-a) is integral with the armature shaft. The armature shaft is mounted on two ball bearings (1-b). The motor is cooled by a fan (1-c) which is mounted on the armature shaft, providing forced air cooling through the motor housing.

2. The primary gear is mounted on the secondary pinion shaft.
3. The secondary pinion is integral with the shaft.
4. The secondary pinion shaft is mounted between two Timken tapered roller bearings.

5. The secondary gear is mounted on the output shaft (5-a) and completes the Helicon R gear train which provides the most efficient reduction. Ratios of 514 to 1, or 1028 to 1 overall reductions are available. (a 163 to 1 high speed reduction is also available using a secondary worm and gear.)
6. When mounted on the crane structure, outboard ball bearings (sealed for life) support the 1-1/4" diameter output shaft (5-a).
7. The gear train is mounted within an aluminum alloy case. The gears are totally enclosed and are oil bath lubricated. The motor (1) mounts directly to the gear case.
8. The secondary pinion shaft (3) extends through the gear housing and provides for attachment of the inertia and load holding brake (8). The springs (8-a) apply the brake band at all times except when the motor is energized. When the motor is energized, the solenoid (8-b) is also energized and will release the brake. Since the motor is reversible, the load is controlled during raising or lowering under power. When the motor and solenoid are de-energized, the brake will hold the load until the motor and solenoid are again energized.
9. Refer to Dwg. AW-008 for maintenance instructions for the motor brushes.

MODEL "B" ACTUATOR ASSEMBLY

P/N 300002

ITEM	QTY.	PART NO.	DESCRIPTION
1	1	300105	MOTOR 24 VDC
2	1	300205	PRIMARY GEAR
3	1	300306	SHAFT
4	1	300405	SECONDARY GEAR
5	1	300503	GEAR CASE
6	1	300601	COVER
7	1	300706	GASKET, SET
8	1	300801	BEARING, CARRIER
9	1	300903	BEARING, CARRIER
10	1	301706	SEAL-OUTPUT SHAFT
11		(REF.)	HOUSING
12	1	301806	SEAL, SECONDARY SHAFT
13	1	301906	SHIM SET
14	1	302008	SHIM SET
15	1	302101	BEARING, CONE
16	1	302201	BEARING, CONE
17	5	005610	CAPSCREW 1/4 - 20 X 3/4 SOC. HD.
18	8	020200	LOCKWASHER, 1/4
19	2	008601	CAPSCREW 3/8 - 16 X 7/8 HX. HD.
20	6	020601	5/16 LOCKWASHER
21	4	008701	3/8 - 16 X 1 SCREW
22	4	021402	LOCKWASHER 3/8 SHAKEPROOF
23	1	040406	#404 WOODRUFF KEY
24	1	060600	#606 WOODRUFF KEY (3/16 X 3/4)
25	1	060601	#E WOODRUFF KEY (3/8 X 1 1/4)
26	3	000209	1/4 PIPE PLUG, SOC. HD.
27	1	302406	VENT, FITTING
28	1	302500	SEAL
29	1	307201	CHANNEL
30	2QT.	REF.	MOBIL OIL # 46 SAE 90
31	1	307701	BRAKE HUB ASSEMBLY
32	6	007811	5/16 - 18 X 1 GR.5 CAPSCREW
33	2	021100	3/8 LOCKWASHER
34	1	300306	SHAFT, OUTPUT
35	1	400600	RETAINING RING (RST-125)
36	4	005903	1/4 - 20 X 7/8 GR.5 CAPSCREW
37	1	800320-003	1/4 X 1/4 X 1 15/16 KEYSTOCK (REF.)
38	1	302102	BEARING CUP
39	1	302202	BEARING CUP
40	1	000210	BUSHING, PIPE

30

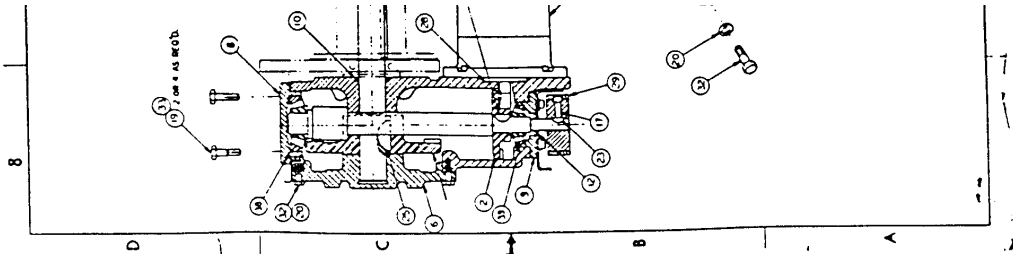

TURNER ACTUATOR ASSEMBLY

P/N 315302

ITEM	QTY.	PART NO.	DESCRIPTION
1	1	300105	MOTOR
2	1	300205	PRIMARY GEAR
3	1	315000	SHAFT
4	1	315100	SECONDARY GEAR
5	1	300503	GEAR CASE
6	1	319200	COVER ASS'Y: SEE NOTE 1
7	1	300706	GASKET, SET
8	1	300801	BEARING, CARRIER
9	1	300903	BEARING, CARRIER
10	1	309800	SHAFT, END COVER
11	1	310800	SEAL, OUTPUT SHAFT
12	1	301806	SEAL, SECONDARY SHAFT
13	1	301906	SHIM SET
14	1	302008	SHIM SET
15	1	302101	BEARING CONE
16	1	302201	BEARING CONE
17	5	005610	1/4 - 20 X 3/4 SOC. HD. CAPSCREW
18	8	020200	1/4 LOCKWASHER
19	1	302102	BEARING CUP
20	6	020601	5/16 LOCKWASHER
21	4	008404	3/8 - 16 X 1" BUTTON SOC. HD. SCREW
22	4	021402	3/8 LOCKWASHER, SHAKEPROOF
23	1	040406	#404 WOODRUFF KEY-HARD (1/8 X 1/2)
24	1	060600	#606 WOODRUFF KEY (3/16 X 3/4)
25	1	315325	KEY 3/8 X 3/8 X 1 1/2 RD. END.
26	3	000209	1/4 PIPE PLUG SOC. HD.
27	1	304406	VENT FITTING
28	1	302500	SEAL
29	1	308201	BRAKE KIT
30	2QT.	REF.	MOBIL OIL #46 SAE 90
31	1	239000	ALEMITE 1728-B ZERK
32	1	000210	BUSHING, PIPE 1/4 X 1/8
33	1	310700	SLEEVE BEARING
34	1	309600	PINION
35	1	400600	RETAINING RING
36	4	005606	1/4 X 7/8 NC GR.5 CAPSCREW
37	1	310600	ACTUATOR COVER
38	6	007811	5/16 X 1 NC GR.5 CAPSCREW
39	1	302202	BEARING CUP
40	4	021100	3/8 LOCKWASHER
41	2	008701	3/8 - 16 X 1 NC GR.5 CAPSCREW
42	2	008601	3/8 - 16 X 7/8 GR.5 CAPSCREW
43			QUILL (REF.)
44			ANCHOR BRACKET (REF.)
45			LINE UP BAR (REF.)

MAINTENANCE OF TURNER ACTUATOR ASSEMBLY

If new gears or bearings are to be installed, new shim set are recommended. Each shim set consists of:

- 1-.005 Blue
- 1-.0075 Clear
- 2-.020 Yellow
- 2-.005 Vellumoid Brown

If a shim is added to the front carrier bearing, you must take the same amount out of the rear. This moves shaft forward toward the motor pinion shaft.

For Example: If you take twenty-thousandths (1 yellow shim) out of the rear, you must add twenty-thousandths to the front if the shaft needs to be moved forward. Reverse this procedure to move the shaft backwards, away from the motor pinion shaft.

10. LUBRICATION

An extreme pressure (EP-80-90) lubricant is used in the gear case (capacity 2 quarts). A chassis lubricant is recommended for the bushing. Check oil level and lubricate bushing every 40 hours of crane operation.

long handle Allen wrench furnished with the unit for this purpose. The motor can now be lifted away from the gear case. The "O" ring (Item 28) serves as an oil seal between the motor pilot and the gear case. Be sure that this "O" ring is in the recess of the gear case before reinstalling the motor.

The motor removal can be accomplished without removing the actuator from the unit as described in Paragraph (1).

GEAR COVER AND PINION REMOVAL

The output shaft (34), cover plate (37), secondary gear (4) and retaining ring (35) are put together as a sub-assembly, and must be assembled in this order before installing in gear case.

Observe location of zerk fitting (31). The cover must be reinstalled in the same relation to the gear case. Remove the two buttonhead capscrews using a 3/16 Allen wrench. Observe that these buttonhead capscrews are on opposite side from the zerk fitting, and are required to provide clearance between the cover and the support arm (43). Remove the remaining hex-head capscrews (38). Remove cover from gear case.

PINION REMOVAL

After removing cover from gear case, remove retaining ring (Item 35) from pinion shaft (34). Pull secondary gear (4) from shaft, using puller or press. Remove key (25) from shaft. Drive shaft through cover, use hammer handle or other soft object. Do not damage shaft. The seal (11) can now be removed.

REMOVAL OF BUSHING

The bushing (33) is installed in the cover in the following manner:

The bushing is pressed into cover, being sure that oil holes through bushing will line up with grease groove in cover.

WHEN ORDERING PARTS, BE SURE TO SPECIFY MODEL AND SERIAL NUMBER.

9. GEAR ADJUSTMENT

The gear adjustment should be checked if new bearing (15 and 16 or new gears (2,3 or 4) are installed. Proceed as follows:

Install motor (1) with bearings (15 and 16) and primary gear (2) installed on shaft (3). Insert shaft in gear case. With bearing cups installed in bearing carriers (8 and 9), install bearing carriers without shims, using capscrews (21 and 36). Adjust the shaft until gear (2) fits snugly against pinion shaft on the motor.

Using plastic color coded shim set (14) as a feeler gauge, add or remove shims until a drag occurs when inserted between carrier (9) and gear case (5). Remove carrier (8) and add two paper shims, one each on front and back sides of the plastic shim set. This usually gives the proper clearance between primary gear and motor pinion. Check backlash between the gear and motor pinion which should be not less than .002" or more than .007". This can be approximated by placing the hand through the large opening in the gear case and determining that the gear has a very small amount of backlash.

Next remove motor and install carrier (9) with plastic shim set and two paper shims. Add or remove plastic shims until bearings fit snugly in cups with the shaft free to turn. Reinstall motor and again check the backlash.

With turner pinion shaft assembly consisting of pinion (34), cover (37) and gear (4) installed against secondary pinion (3), determine thickness of shim set required in the manner described above. Check the backlash for the full 360 degree rotation.

RELAY PANEL ASSEMBLY 6006 SERIES

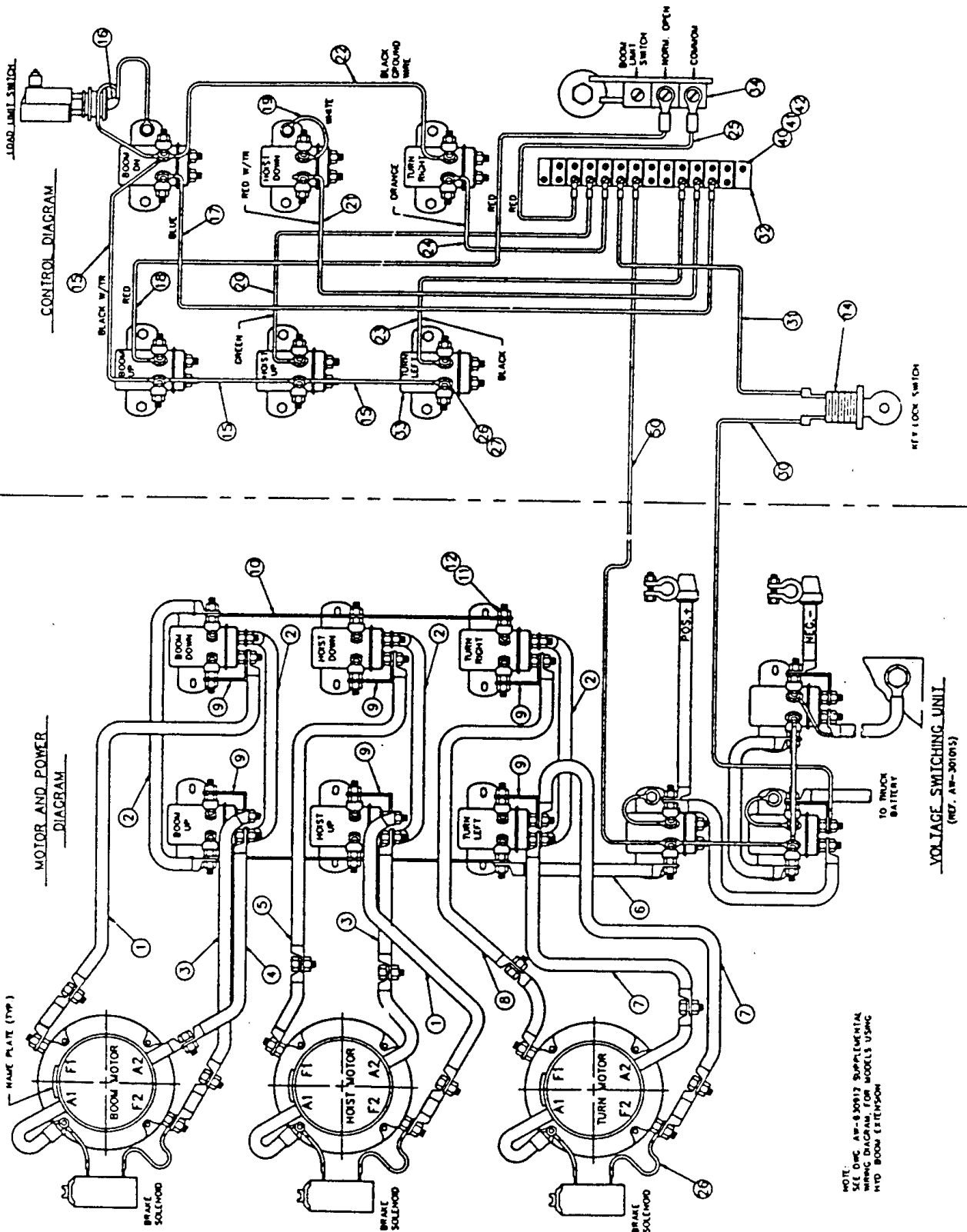

RELAY PANEL ASSEMBLY 6006 SERIES

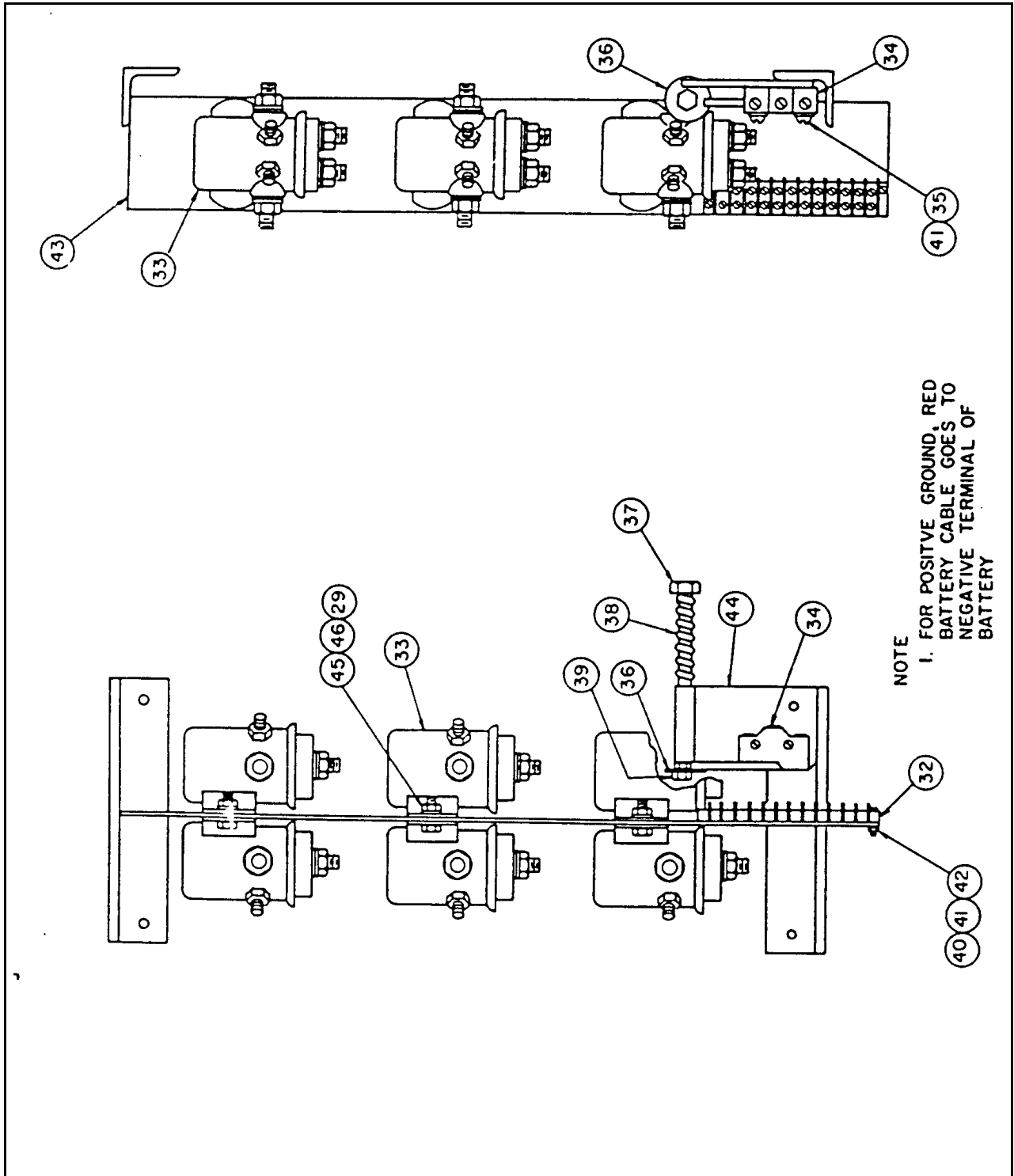

RELAY PANEL ASSEMBLY

6006 SERIES

ITEM	QTY.	PART NO.	DESCRIPTION
1	3	622316	CONDUCTOR
2	4	600304	CONDUCTOR
3	1	622310	CONDUCTOR
4	1	622306	CONDUCTOR
5	1	622321	CONDUCTOR
6	1	600316	CONDUCTOR
7	1	622326	CONDUCTOR
8	1	622331	CONDUCTOR
9	6	658300	BUS BAR
10	2	658500	BUS BAR
11	36	REF.	5/16 N.F. CAD PL. HLF. NUT
12	24	020700	5/16 LOCKWASHER INT. LK.
13	3	660000	BRAKE LEAD ASSEMBLY
14	1	640700	SWITCH, PENDANT LOCK
15	3	660406	CONDUCTOR (BLACK W/T)
16	1	REF.	CONDUCTOR
17	1	660223	CONDUCTOR (BLUE)
18	1	660226	CONDUCTOR (RED)
19	1	659904	CONDUCTOR (WHITE)
20	1	660229	CONDUCTOR (GREEN)
21	1	660218	CONDUCTOR (RED W/T)
22	1	660415	CONDUCTOR (BLACK)
23	1	660206	CONDUCTOR (BLACK)
24	1	660230	CONDUCTOR (ORANGE)
25	1	660310	CONDUCTOR (RED)
26	24	REF.	#10 - 32 HX. NUT, CAD. PL.
27	12	020001	#10 LOCKWASHER CAD. PL.
28			
29	6	020200	WASHER, SP. LK. 1/4
30	1	REF.	CONDUCTOR (RED)
31	1	660312	CONDUCTOR (WHITE)
32	1	635200	TERMINAL BOARD
33	6	200182	RELAY, 12 V.
34	1	654100	SWITCH
35	2	000404	SCREW RD. SLT. HD. # 6-32 X 5/8 LG.
36	1	020900	5/16 X 1 1/4 O.D. FENDER WASHER
37	1	007808	5/16 - 18 N.C. X 6" HX. HD. SCREW
38	1	301401	SPRING
39	2	016500	5/16 - 18 N.C. HX. NUT
40	2	000602	#6-32 N.C. X 1" RD. HD. MACH. SCREW
41	4	019600	#6 LOCKWASHER
42	2	015400	NUT HX. # 6-32
43	1	305401	PANEL BRACKET MEMBER
44	1	654000	BOOM, LIMIT BRACKET
45	6	005901	SCREW, HX. HD. 1/4 - 20 N.C. X 1/2" LG.
46	6	015900	NUT HX. 1/4 - 20 N.C.
47	4	663100	CABLE TIE (NOT SHOWN)
48	2	663200	CABLE TIE (NOT SHOWN)
49			
50	1	REF.	CONDUCTOR (BLACK W/T)

RELAY PANEL ASSEMBLY

220/24V 110/24V

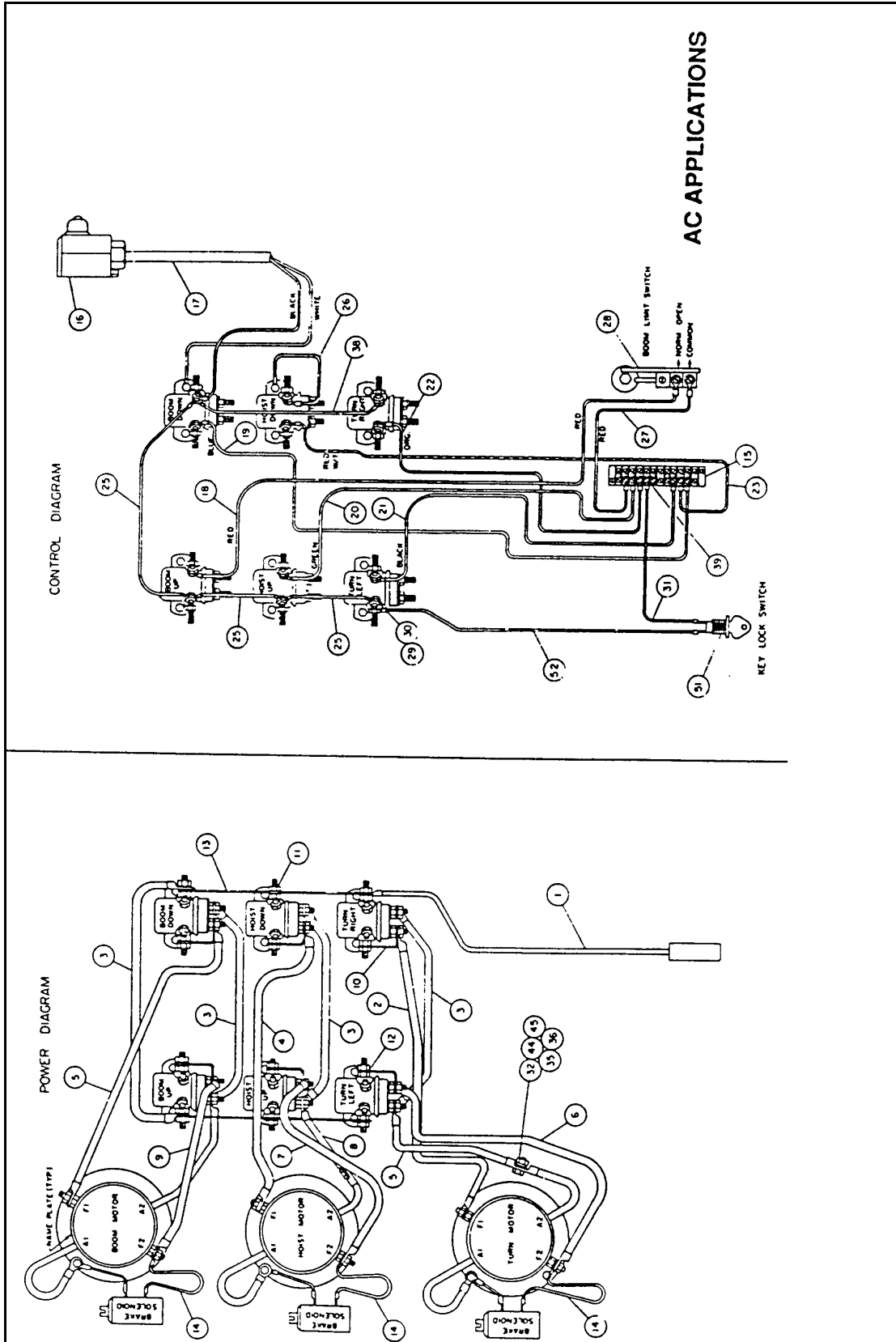

AC APPLICATIONS

RELAY PANEL ASSEMBLY

220/24V 110/24V

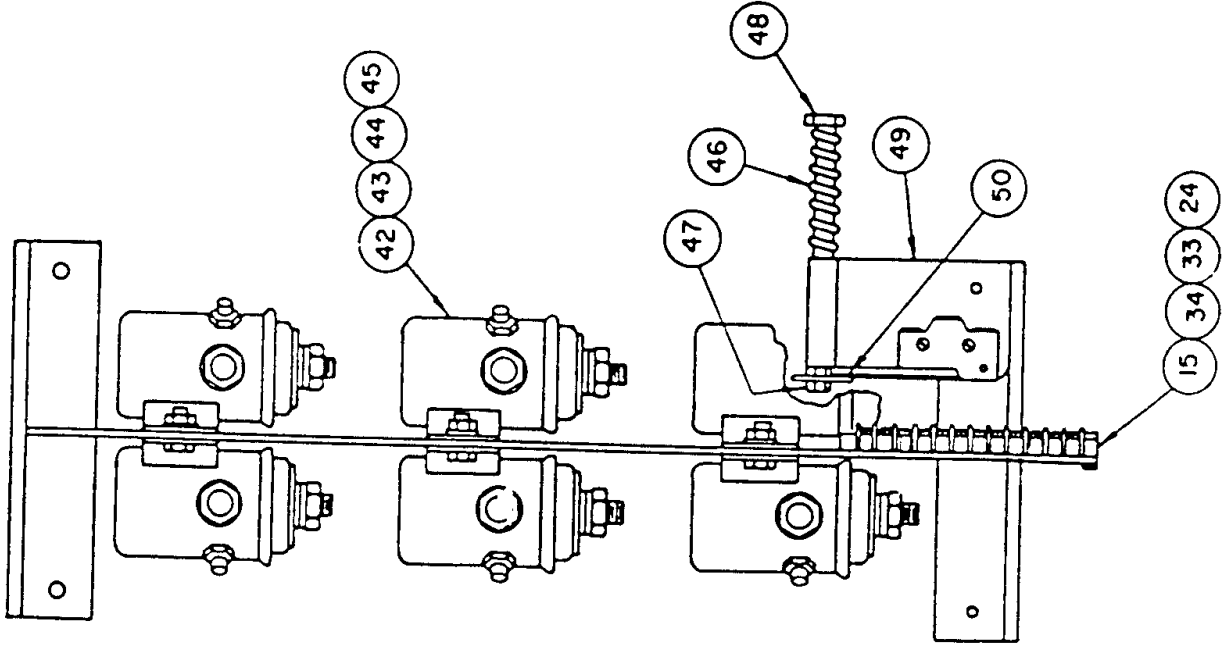
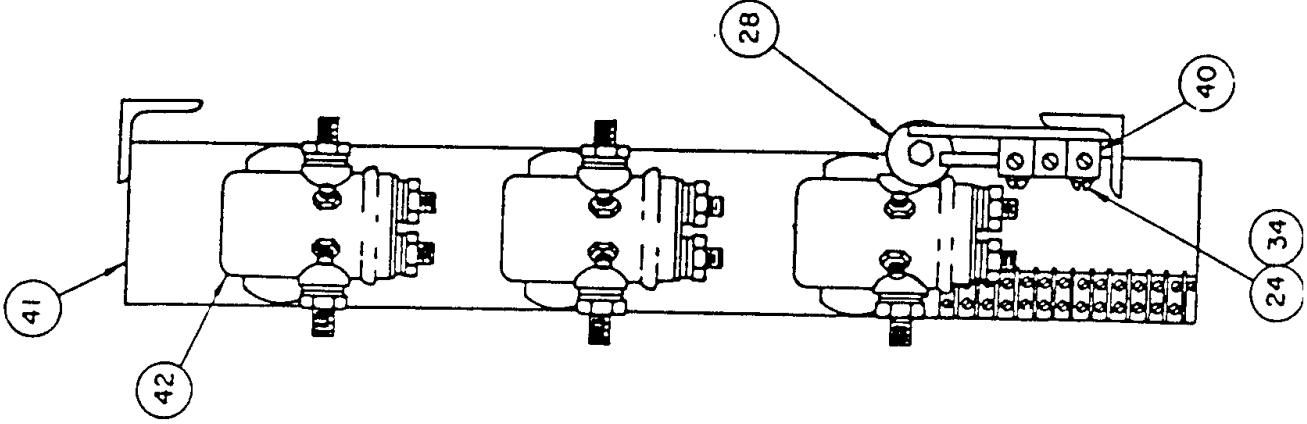

RELAY PANEL ASSEMBLY

220/24V 110/24V

ITEM	QTY.	PART NO.	DESCRIPTION
1	1	614230	CONDUCTOR
2	1	622331	CONDUCTOR
3	4	600304	CONDUCTOR
4	1	622321	CONDUCTOR
5	2	622318	CONDUCTOR
6	1	622326	CONDUCTOR
7	1	622316	CONDUCTOR
8	1	622304	CONDUCTOR
9	1	622310	CONDUCTOR
10	6	658300	CONDUCTOR
11	28	016800	5/16 N.F. CAD. PL. HALF NUT
12	28	020700	5/16 INTERNAL SHAKEPROOF LOCKWASHER
13	2	658500	RELAY CONDUCTOR
14	3	660000	BRAKE LEAD ASS'Y
15	1	635200	TERNIMAL BOARD
16	1	646900	SWITCH
17	1	655636	CONDUCTOR ASS'Y
18	1	660226	CONDUCTOR
19	1	660223	CONDUCTOR
20	1	660229	CONDUCTOR
21	1	660206	CONDUCTOR
22	1	660230	CONDUCTOR
23	1	660218	CONDUCTOR
24	4	019600	#6 SPLIT LOCKWASHER
25	3	660406	CONDUCTOR
26	1	659904	CONDUCTOR
27	1	660310	CONDUCTOR
28	1	659700	BOOM LIMIT SWITCH
29	16	015600	#10-32 CAD. PL. HX. NUT
30	16	020001	#10 CAD. PL. LOCKWASHER
31	1	660312	CONDUCTOR
32	2	005901	1/4 X 1/2 CAD. PL. CAPSCREW
33	2	015400	NUT HX. #6-32
34	4	000404	SCREW RD. SLOT HD. #6-32 X 5/8
35	4.5"	800589	ELECT. INSULATION PUTTY
36	90"	800580	BLK. VINYL ELECT. TAPE
37	17	634401	CABLE TIE (MEDIUM)
38	1	660417	CONDUCTOR (BLK W/T)
39	1	636600	JUMPER BAR
40	1	654100	SWITCH
41	1	305401	PANEL, BRACKET
42	6	650524	RELAY 24V
43	6	005401	SCREW, HX. HD. 1/4 - 20 X 5/8"
44	8	015900	NUT, HX. HD. 1/4 - 20 X 1/2"
45	8	020200	WASHER SPLIT LOCK 1/4
46	1	301401	SPRING
47	2	016500	5/16 - 18 N.C. HX. NUT
48	1	008000	5/16 - 18 N.C. X 6" HX. CAPSCREW
49	1	654000	BOOM LIMIT BRACKET
50	1	020900	5/16 FENDER WASHER 1 1/4 O.D.

RELAY PANEL ASSEMBLY
220/24V 110/24V

ITEM	QTY.	PART NO.	DESCRIPTION
51	1	640700	SWITCH, PENDANT LOCK
52	1	660240	CONDUCTOR

RELAY PANEL ASSEMBLY FOR REMOVABLE PENDANT

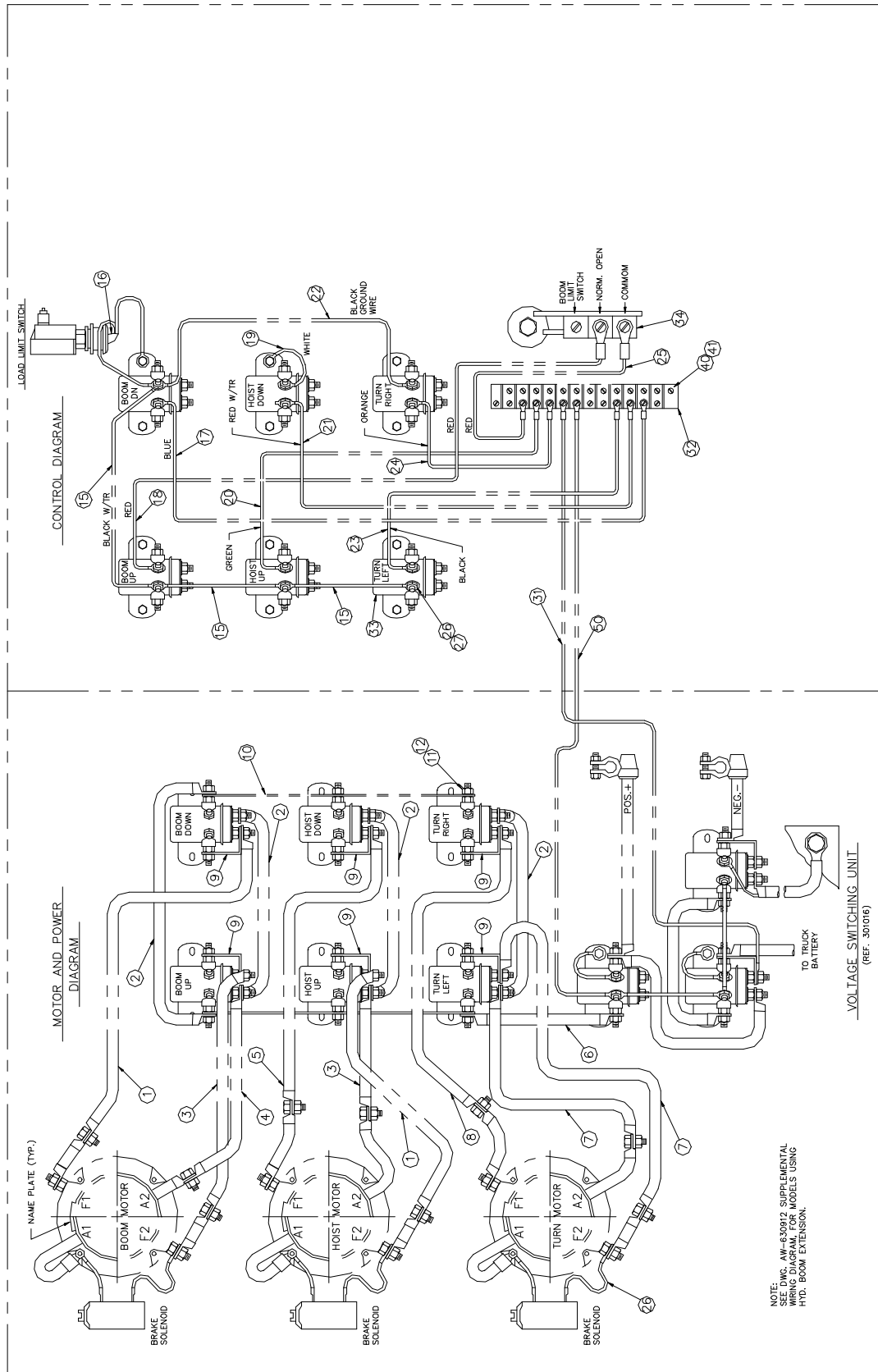

NOTE:
SEE Dwg. AW-630912 SUPPLEMENTAL
PARTS AND EXTENSION MODELS USING
HYD. BOOM EXTENSION.

RELAY PANEL ASSEMBLY FOR REMOVABLE PENDANT

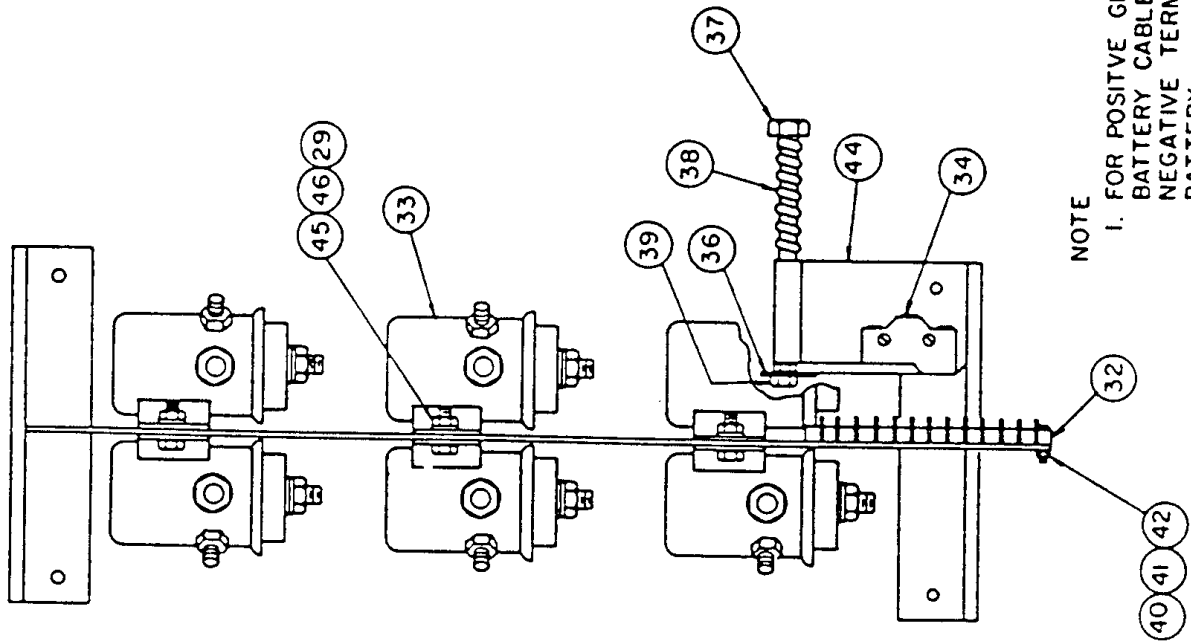
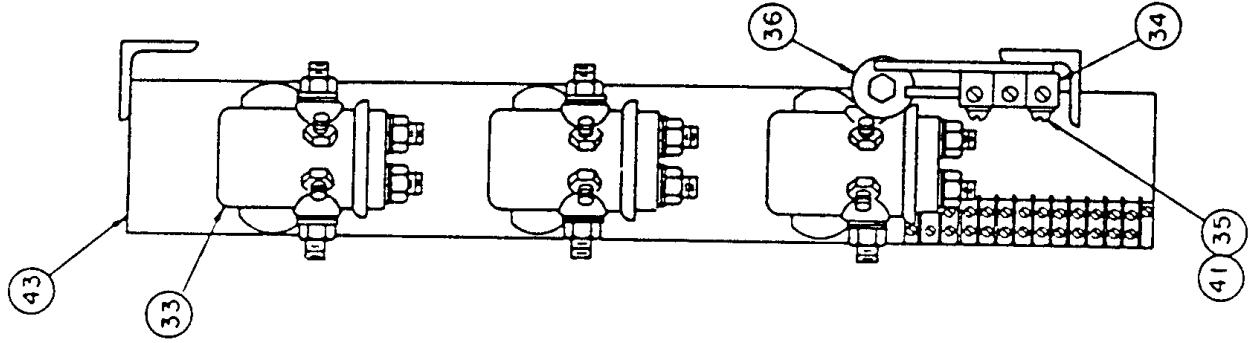

NOTE
 1. FOR POSITIVE GROUND, RED BATTERY CABLE GOES TO NEGATIVE TERMINAL OF BATTERY

RELAY PANEL ASSEMBLY FOR REMOVABLE PENDANT

ITEM	QTY.	PART NO.	DESCRIPTION
1	2	622316	CONDUCTOR
2	4	600304	CONDUCTOR
3	2	622310	CONDUCTOR
4	1	622306	CONDUCTOR
5	1	622321	CONDUCTOR
6	1	600316	CONDUCTOR
7	2	622326	CONDUCTOR
8	1	622331	CONDUCTOR
9	6	658300	BUS BAR
10	2	658500	BUS BAR
11	36	016800	5/16 N.F. CAD PL. HALF NUT
12	24	020700	5/16 LOCKWASHER INT. LK.
13	3	660000	BRAKE LEAD ASSEMBLY
14			
15	3	660406	CONDUCTOR (BLACK W/TR)
16	1	655636	CONDUCTOR
17	1	660223	CONDUCTOR (BLUE)
18	1	660226	CONDUCTOR (RED)
19	1	659904	CONDUCTOR (WHITE)
20	1	660229	CONDUCTOR (GREEN)
21	1	660218	CONDUCTOR (RED W/TR)
22	1	660415	CONDUCTOR (BLACK)
23	1	660206	CONDUCTOR (BLACK)
24	1	660230	CONDUCTOR (ORANGE)
25	1	660310	CONDUCTOR (RED)
26	24	015600	#10-32 HX. NUT CAD. PL. INT.
27	12	020001	#10 LOCKWASHER CAD. PL.
28			
29	6	020200	WASHER SP. LK. 1/4
30			
31	1	330664	CONDUCTOR (RED)
32	1	635200	TERMINAL BOARD
33	6	200182	RELAY 12 VOLT
34	1	654100	SWITCH
35	2	000404	SCREW RD. SLT. HD. #6-32 X 5/8" LG.
36	1	020900	5/16 X 1 1/4 O.D. FENDER WASHER
37	1	007808	5/16 - 18 N.C. X 6" HX. HD. SCREW
38	1	301401	SPRING
39	2	016500	5/16 N.C. HX. NUT
40	2	000602	#6-32 N.C. X 1" RD. HD. MACH. SCREW
41	4	019600	#6 LOCKWASHER
42	2	015400	#6-32 HX. NUT
43	1	305401	PANEL BRACKET MEMBER
44	1	654000	BOOM LIMIT BRACKET
45	6	005901	SCREW HEX. HD. 1/4 - 20 N.C. X 1/2"
46	6	015900	1/4 - 20 N.C. HX. NUT
47	4	663100	CABLE TIE (NOT SHOWN)
48	2	663200	CABLE TIE (NOT SHOWN)
49			
50	1	660406	CONDUCTOR (BLACK W/TR)

SUPPLEMENTAL WIRING DIAGRAM FOR HYD BOOM EXTENSION

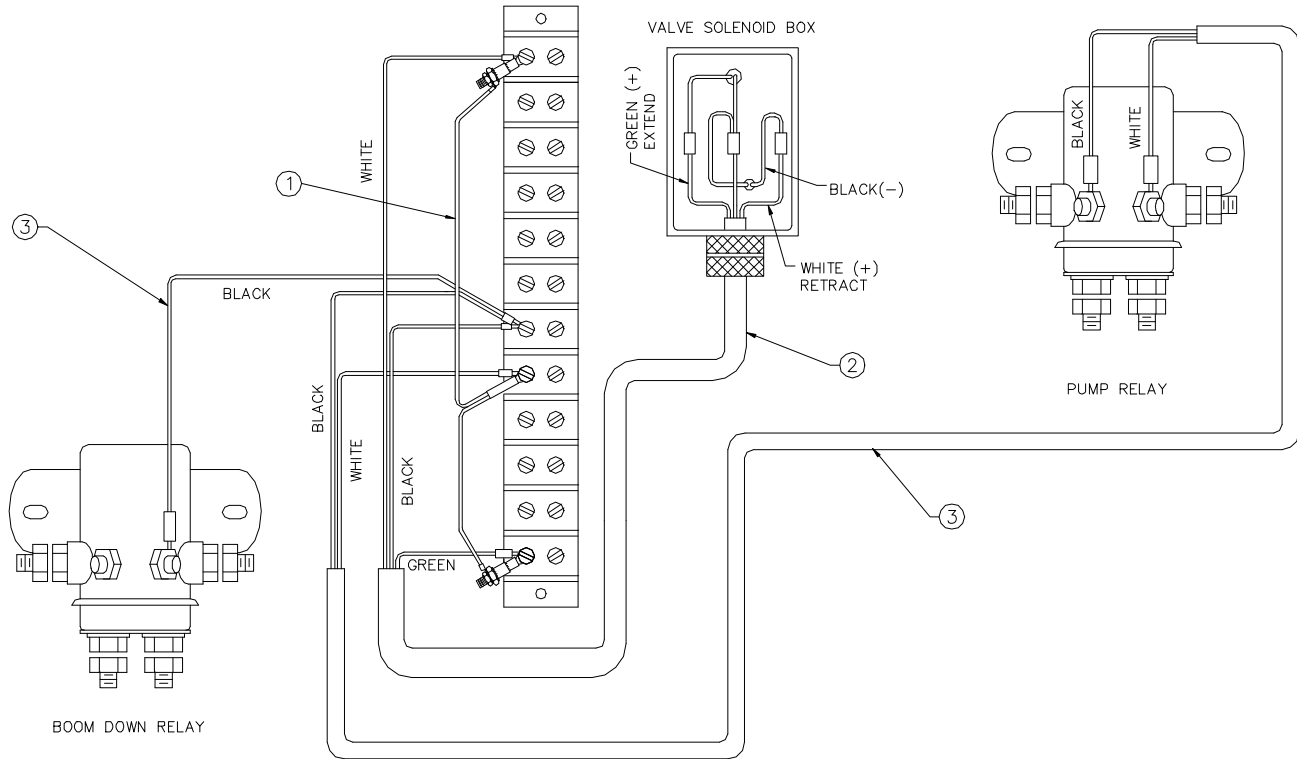

<u>ITEM</u>	<u>QTY</u>	<u>P/N</u>	<u>DESCRIPTION</u>
1	1	630907	CONDUCTOR ASSEMBLY
2	1	630908	CONDUCTOR ASSEMBLY
3	1	630913	CONDUCTOR ASSEMBLY

ELECTRICAL SCHEMATIC

12/24 VOLT

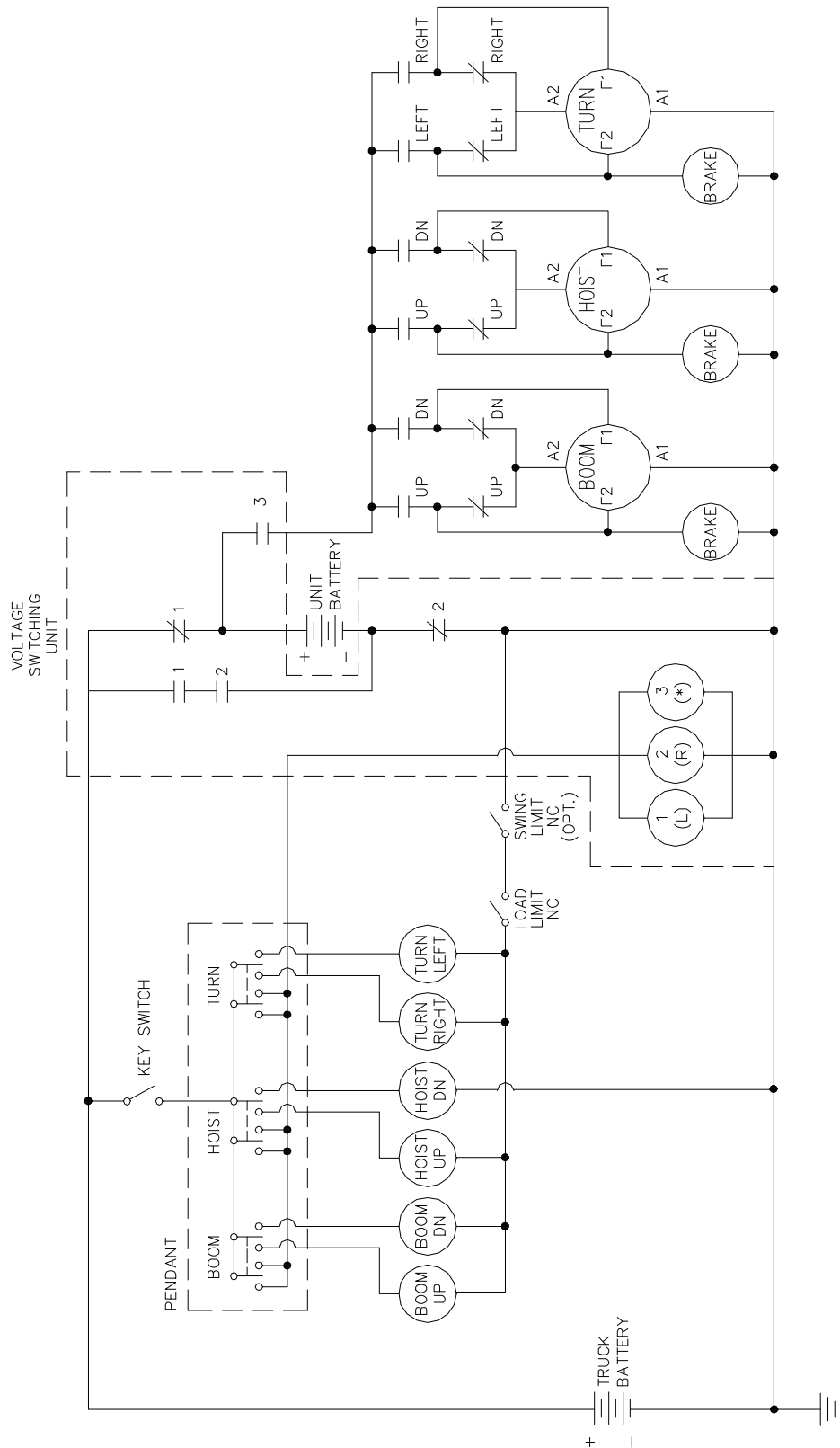

ELECTRICAL SCHEMATIC

12/24 VOLT POWER EXTENSION

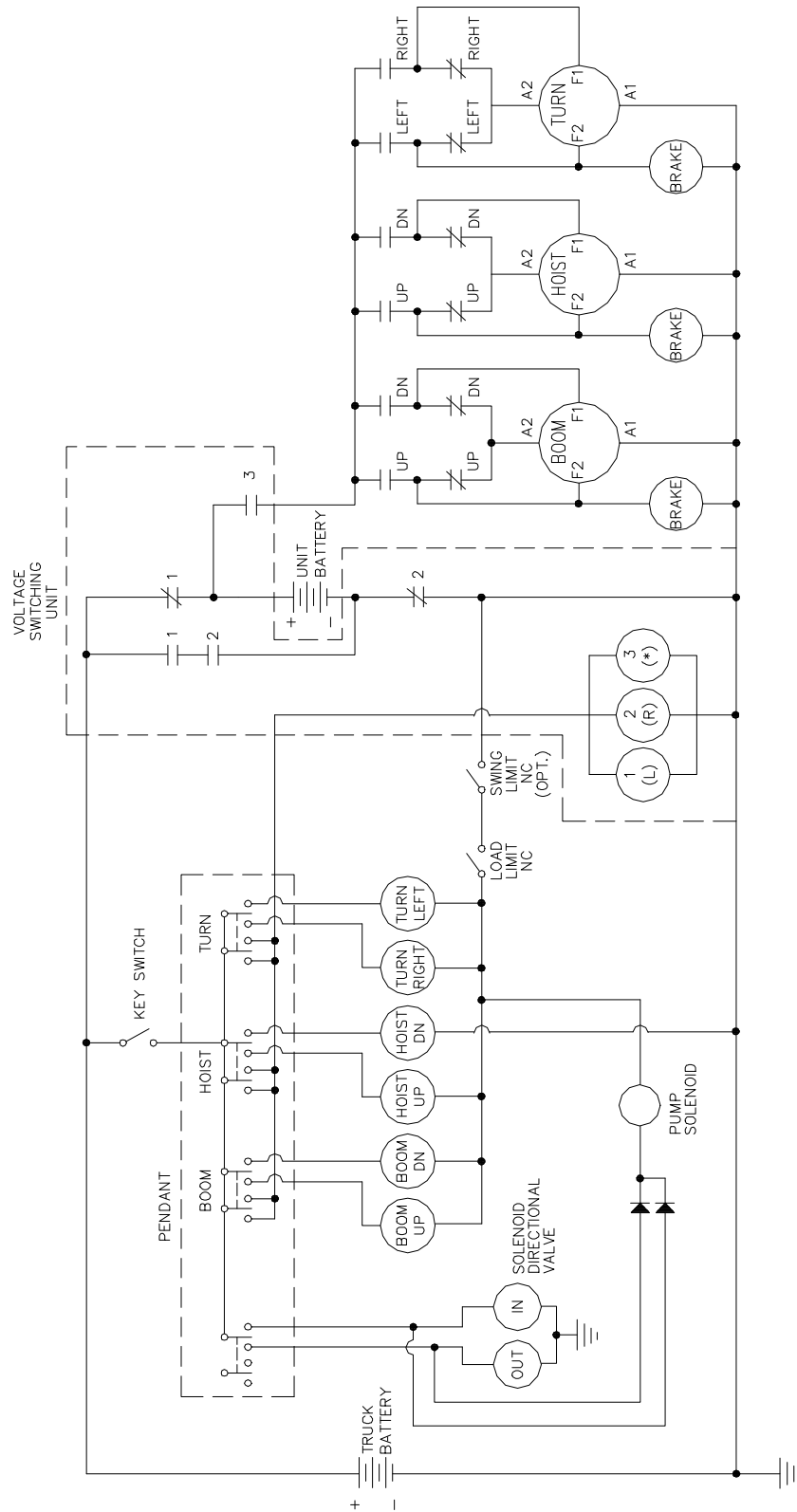

ELECTRICAL SCHEMATIC

24 VOLT

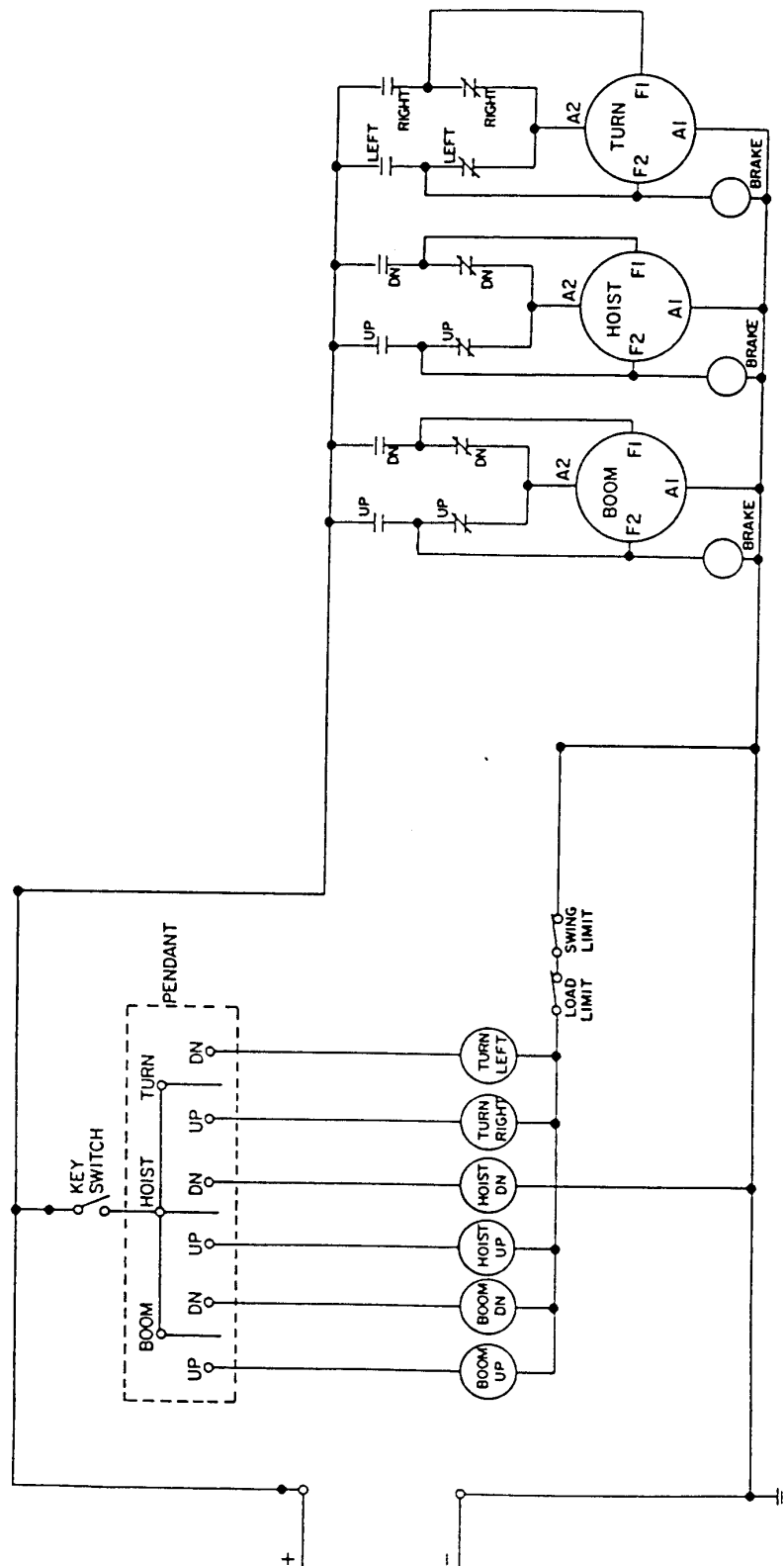

VOLTAGE CONVERTER ASSEMBLY

A/W-330070

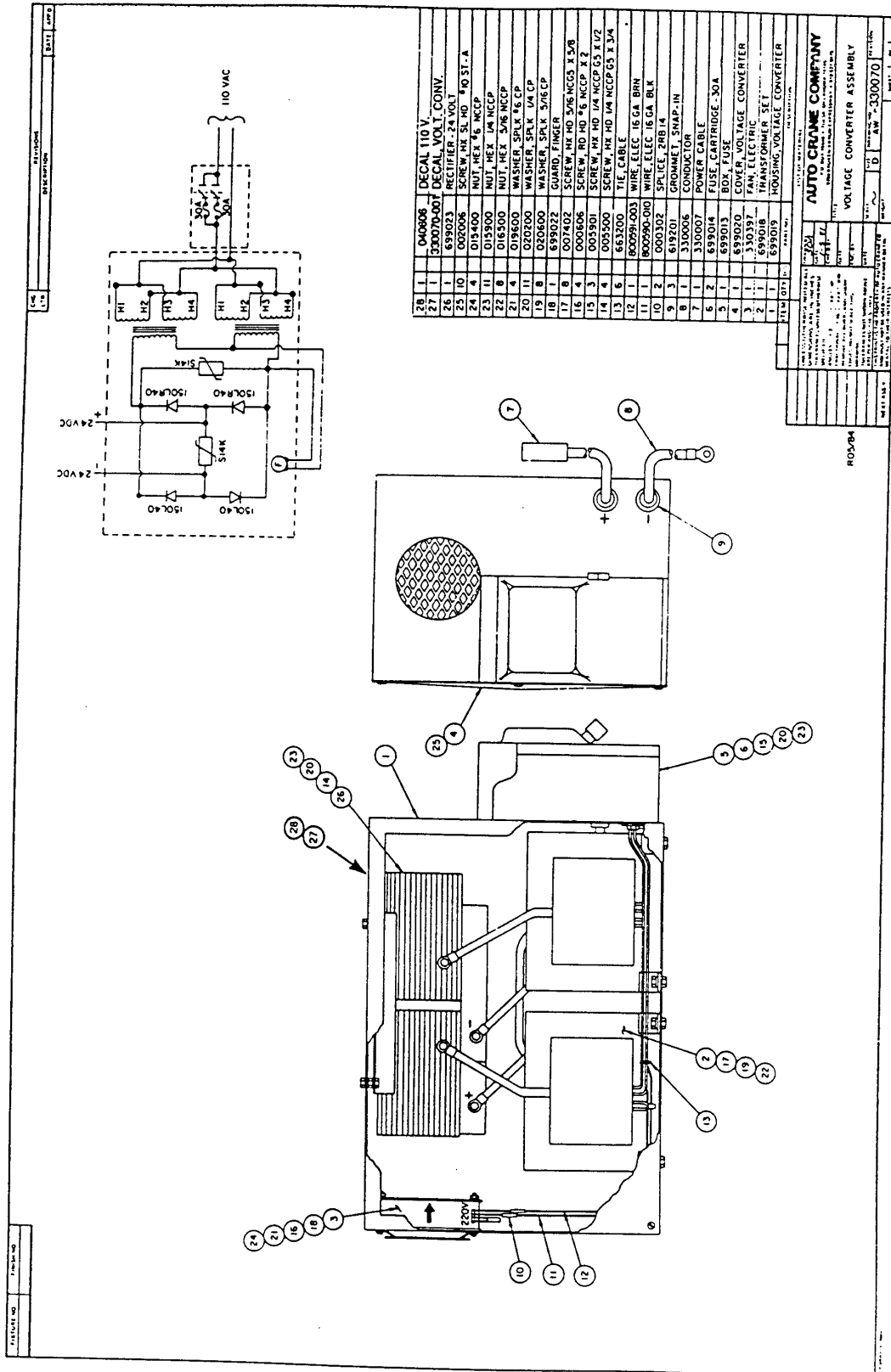

VOLTAGE CONVERTER ASSEMBLY

220VAC / 24VDC

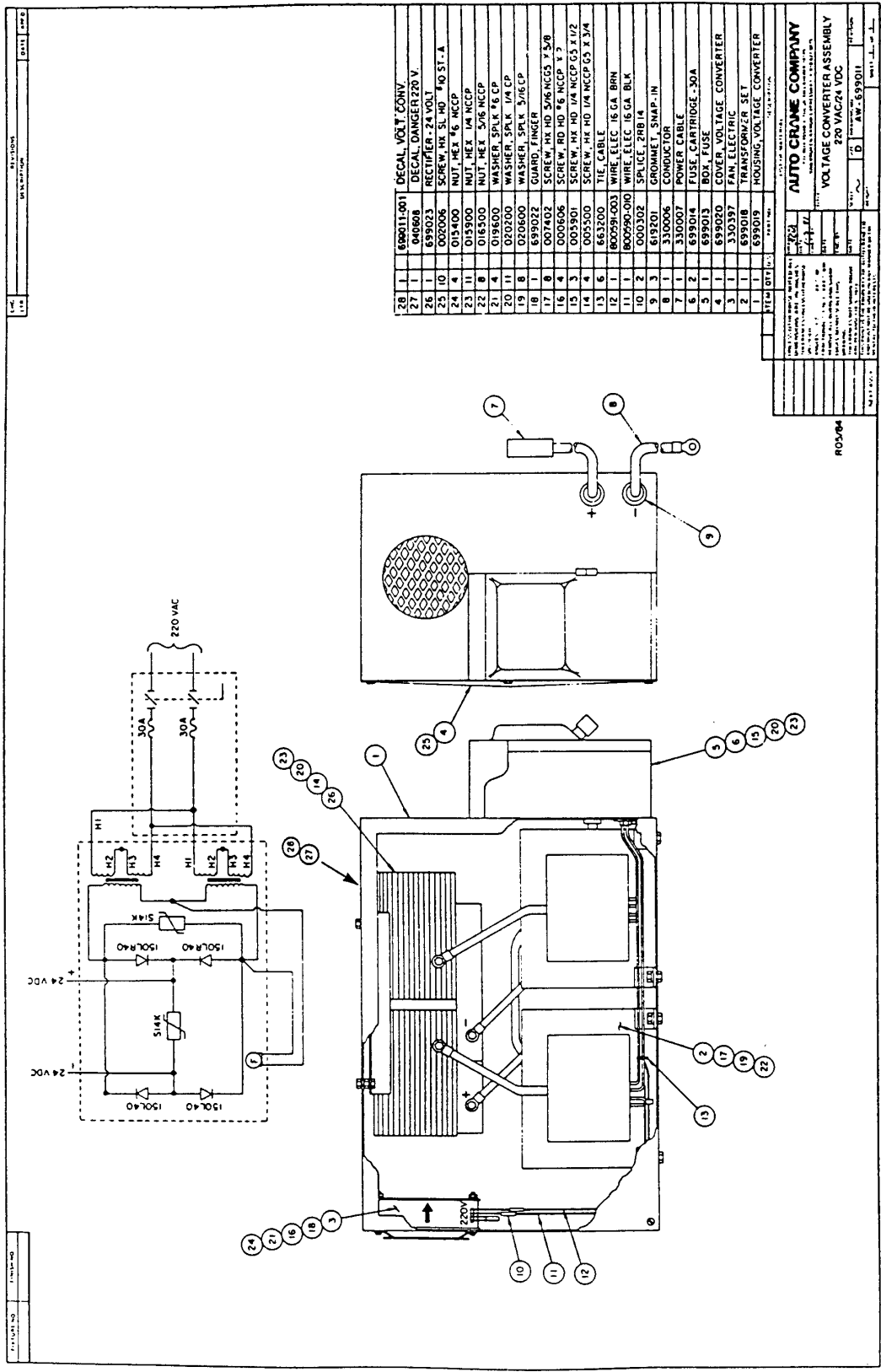

RECTIFIER 24 VOLT

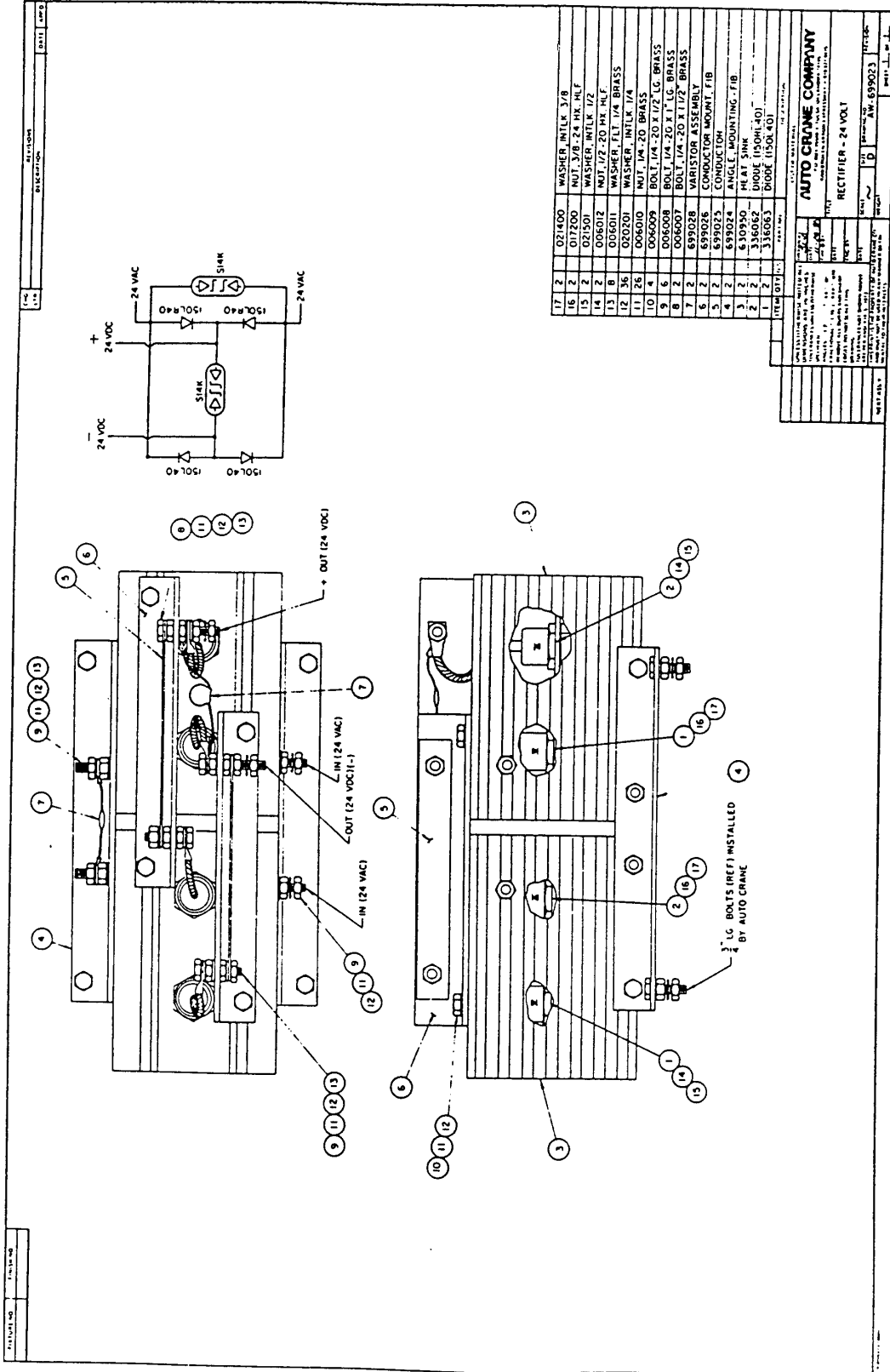

TROUBLE SHOOTING THE VOLTAGE CONVERTER

PROBLEM	PROCEDURE
No Output Voltage	<p>Turn unit on with the lever on the fuse box. Check fuses in the fuse box. Check power to the fuse box; it should be 110 volts (or 220 volts). Check inside the converter to see if the transformer output leads are connected. Check all the diodes to see if they are burned open.</p>
Low voltage output	<p>Check input voltage. The 110 volt unit requires a minimum of 110 volts. The 220 volt unit requires a minimum of 210 volts. Check to be sure you do not have a 220 volt unit in place of a 110 volt unit. Check the transformer output to ground. it should be 24-34 volts ac.</p>
High Output Voltage	<p>Check input line voltage. The 110 volt unit takes a maximum of 120 volts and the 220 volt unit takes a maximum of 240 volts. Check to be sure a 110 volt unit has not been substituted for a 220 volt unit.</p>
AC Voltage on Converter Output	<p>There is a bad diode in the bridge. Remove diodes and check for polarity and current blocking.</p>

VOLTAGE CHECK

220/24 CONVERTER

1. Connect 220V leads to generator or other 220V source.
2. Check voltage across top of fuses in fuse box rectifier. Voltage should be 220VAC \pm 5%. If voltage is above 230 or below 210 check voltage at source.
3. If voltage in Step (2) is correct, close fuse box and turn on rectifier.
4. Check rectifier output. Voltage on D.C. output leads should read 24 to 34 V.D.C. unloaded.
5. Turn rectifier off.
6. Connect DC leads to crane.
7. Turn rectifier on.
8. Connect voltmeter positive lead to hoist motor stud F2 (Stud that brake lead connects to) and negative lead to crane case ground. With 2000 lb. load on crane, hoist (with 3 line block). Start hoist in up condition. Voltmeter should read 22 to 28 VDC.

110/24 CONVERTER

1. Connect 110V leads to generator or other 110V source.
2. Check voltage from top of fuses to buss bar in bottom of box. Voltage should be 110V \pm 5%. If voltage is above 116V check voltage at source.
NOTE: Fuses are connected in parallel; checking from the top of either fuse to buss bar will give the same voltage.
3. If voltage in Step (2) is correct, close fuse box and turn on rectifier.
4. Check rectifier output. Voltage on D.C. output leads should read 24 to 34 VDC unloaded.
5. Turn rectifier off.
6. Connect DC leads to crane.
7. Turn rectifier on.
8. Connect voltmeter positive lead to hoist motor stud F2 (Stud that brake lead connects to) and negative lead to crane case ground. With 2000 lb. load on crane, hoist (with 3 line block). Start hoist in up condition. Voltmeter should read 22 to 28 VDC.

POWER CABLE

AW-330007

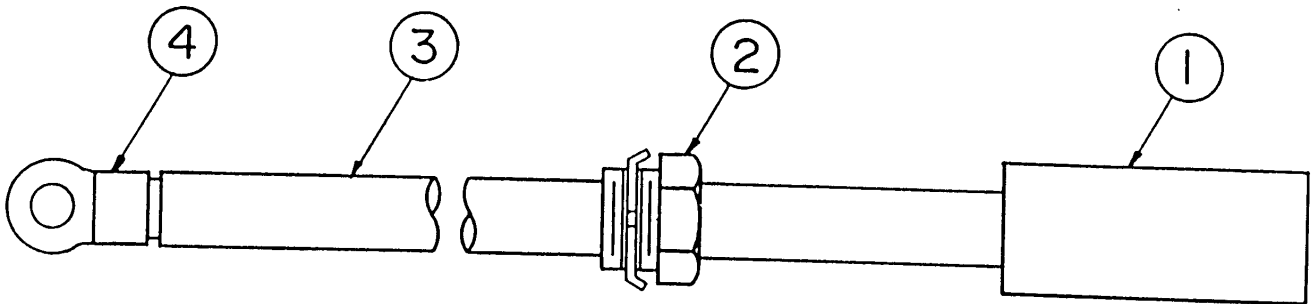

<u>ITEM</u>	<u>QTY</u>	<u>P/N</u>	<u>DESCRIPTION</u>
1	1	669200	CONDUCTOR SWIVEL-FEMALE
2	1	005000	TERMINAL
3	1	002801	BUSHING W/NUT
4	1	341216	CONDUCTOR 4 GA

VOLTAGE SWITCHING UNIT 6006 SERIES

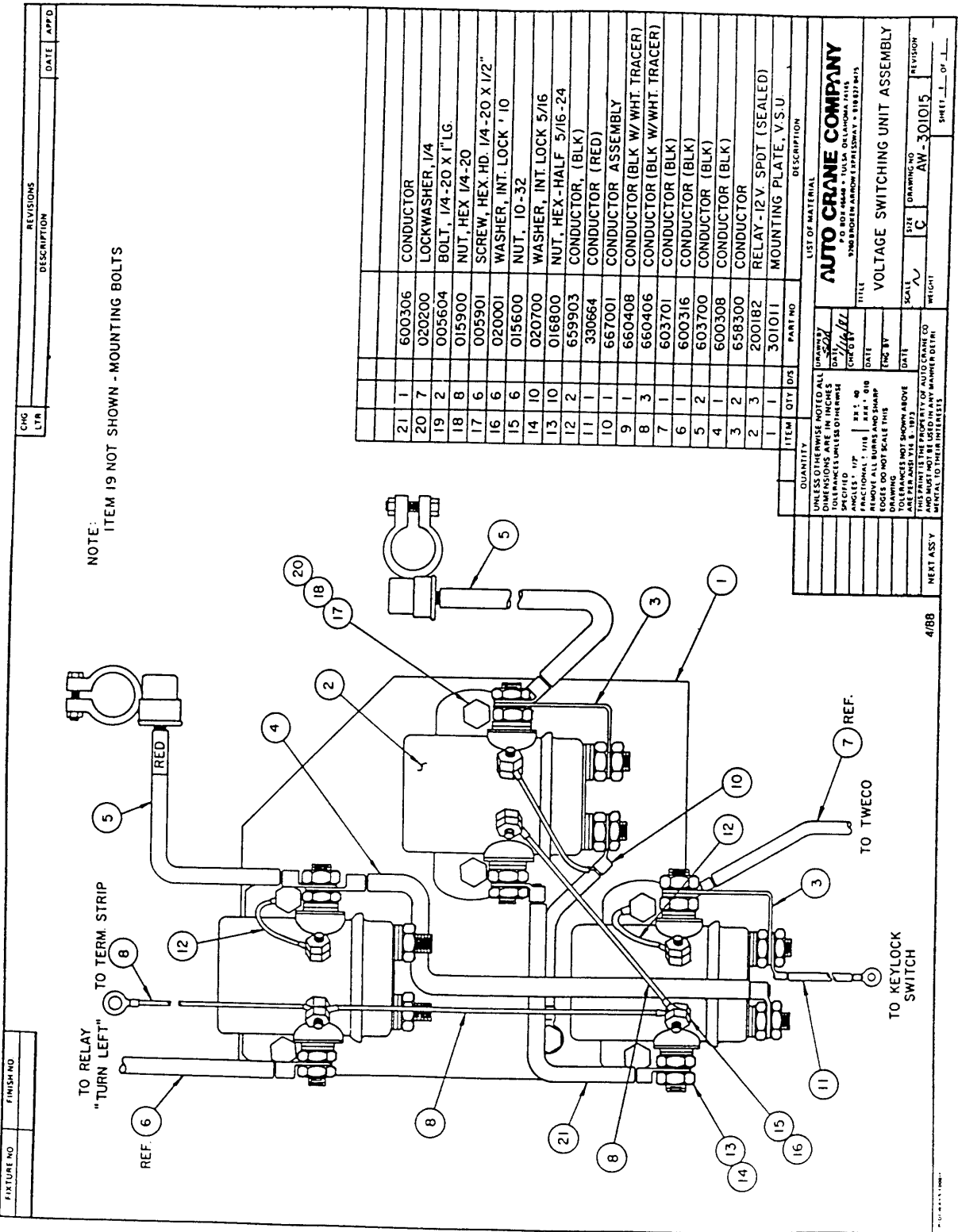

NOTE:
ITEM 19 NOT SHOWN - MOUNTING BOLTS

ITEM	QTY	DES	PART NO	DESCRIPTION
21	1		600306	CONDUCTOR
20	7		020200	LOCKWASHER, 1/4
19	2		005604	BOLT, 1/4-20 X 1" LG.
18	8		015900	NUT, HEX 1/4-20
17	6		005901	SCREW, HEX. HD. 1/4-20 X 1/2"
16	6		020001	WASHER, INT. LOCK ' 10
15	6		015600	NUT, 10-32
14	10		020700	WASHER, INT. LOCK 5/16
13	10		016800	NUT, HEX - HALF 5/16-24
12	2		659903	CONDUCTOR, (BLK)
11	1		330664	CONDUCTOR ASSEMBLY
10	1		667001	CONDUCTOR (BLK W/ WHT. TRACER)
9	1		660408	CONDUCTOR (BLK)
8	3		660406	CONDUCTOR (BLK)
7	1		603701	CONDUCTOR (BLK)
6	1		600316	CONDUCTOR (BLK)
5	2		603700	CONDUCTOR (BLK)
4	1		600308	CONDUCTOR (BLK)
3	2		658300	CONDUCTOR
2	3		200182	RELAY - 12 V. SPDT (SEALED)
1	1		301011	MOUNTING PLATE, V.S.U.

QUANTITY		LIST OF MATERIAL	
ITEM	QTY	DES	PART NO
21	1		600306
20	7		020200
19	2		005604
18	8		015900
17	6		005901
16	6		020001
15	6		015600
14	10		020700
13	10		016800
12	2		659903
11	1		330664
10	1		667001
9	1		660408
8	3		660406
7	1		603701
6	1		600316
5	2		603700
4	1		600308
3	2		658300
2	3		200182
1	1		301011

USE SCISSOR CUT TO REMOVE UNNECESSARY DIMENSIONS AND TOLERANCES UNLESS OTHERWISE SPECIFIED.
 DECIMALS: 1/16, 1/32, 1/64, 3/16, 1/8, 3/16, 1/4, 5/16, 3/8, 1/2, 5/8, 3/4, 7/8, 1, 1 1/8, 1 1/4, 1 1/2, 1 3/4, 2, 2 1/4, 2 1/2, 3, 3 1/4, 3 1/2, 4, 4 1/4, 4 1/2, 5, 5 1/4, 5 1/2, 6, 6 1/4, 6 1/2, 7, 7 1/4, 7 1/2, 8, 8 1/4, 8 1/2, 9, 9 1/4, 9 1/2, 10, 10 1/4, 10 1/2, 11, 11 1/4, 11 1/2, 12, 12 1/4, 12 1/2, 13, 13 1/4, 13 1/2, 14, 14 1/4, 14 1/2, 15, 15 1/4, 15 1/2, 16, 16 1/4, 16 1/2, 17, 17 1/4, 17 1/2, 18, 18 1/4, 18 1/2, 19, 19 1/4, 19 1/2, 20, 20 1/4, 20 1/2, 21, 21 1/4, 21 1/2.

REMOVE ALL BURRS AND SHARP EDGES DO NOT SCALE THIS DRAWING.
 TOLERANCES NOT SHOWN ABOVE ARE PER ANSI Y14.5-1983.
 THIS PRINT IS THE PROPERTY OF AUTO CRANE CO. IT IS TO BE USED ONLY FOR THE PART IDENTIFIED HEREIN.
 METAL TO THEIR INTERESTS.

FIXTURE NO	FINISH NO	CHG LTR	REVISIONS	DATE	APPD

4/88

PENDANT ASSEMBLY 3 FUNCTION

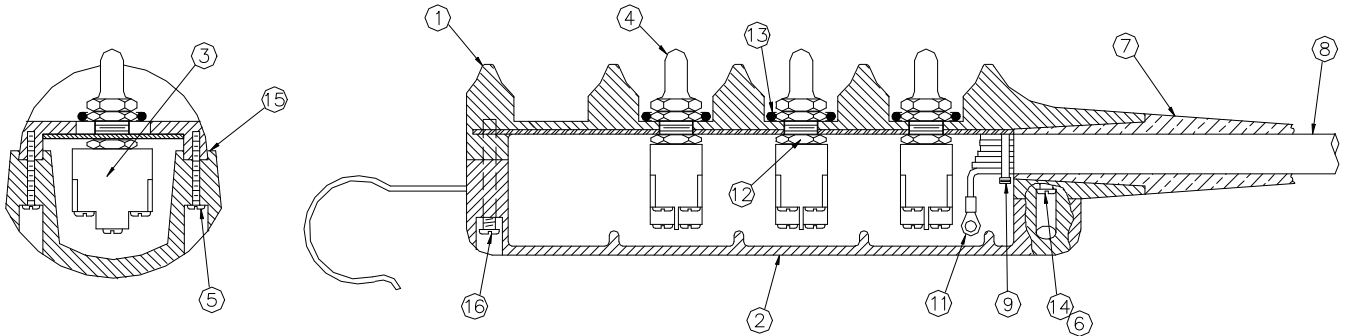

642423	26 FT.	CONDUCTOR CABLE
642450	53 FT.	
642440	43 FT.	
642437	40 FT.	
642430	33 FT.	
642426	29 FT.	
642420	23 FT.	
642415	18 FT.	
PART NO.	LENGTH	DESCRIPTION

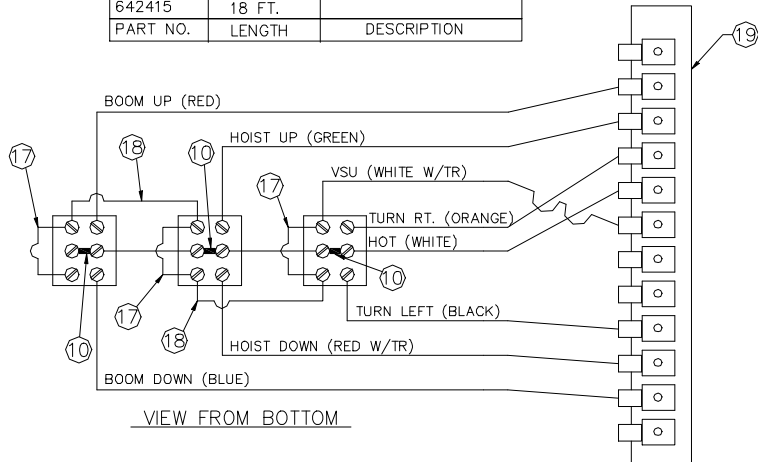

PENDANT ASSEMBLY 3 FUNCTION

<u>ITEM</u>	<u>QTY</u>	<u>P/N</u>	<u>DESCRIPTION</u>
1	1	631602	PENDANT HOUSING
2	1	631700	BOTTOM COVER
3	3	634200	TOGGLE SWITCH
4	3	640302	BOOT-TOGGLE SWITCH
5	10	005001	SCREW PN HD #8 X 3/4
6	2	005101	SCREW PN HD #8 X 1 1/4
7	1	633801	CABLE ADAPTER
8	23 FT	800630	CONDUCTOR CABLE (23 FT) STD
9	2	634401	TY-RAP CABLE TIE
10	3	636600	JUMPER
11	8	000101	TERMINALS T & B
12	3	675271	NUT
13	3	642100	O-RING
14	3	019700	WASHER SP LK #8
15	21 IN	800580	3/4 WIDE OKONITE RUBBER TAPE
16	1	004700	SCREW PN HD #8 X 1 1/2
17	3	622346	CONDUCTOR ASSY 2 1/8
18	2	622347	CONDUTCOR ASSY 3 1/8
19	1	635301	TERMINAL STRIP

PENDANT ASSEMBLY 4 FUNCTION

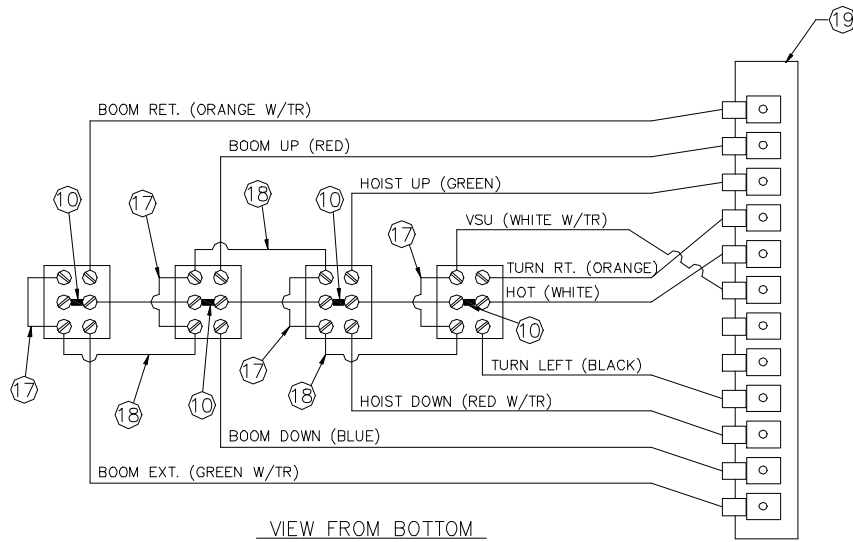
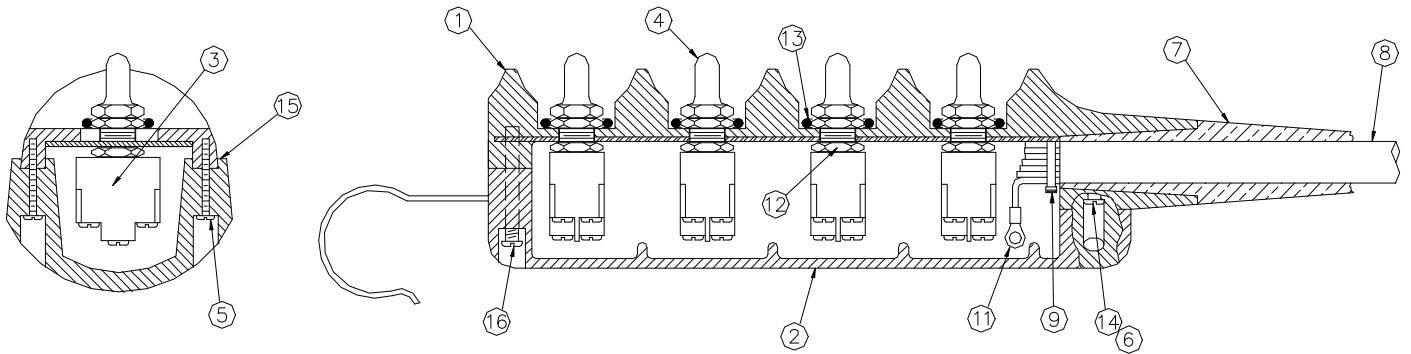

PENDANT ASSEMBLY 4 FUNCTION

<u>ITEM</u>	<u>QTY</u>	<u>P/N</u>	<u>DESCRIPTION</u>
1	1	631601	PENDANT HOUSING
2	1	631700	BOTTOM COVER
3	4	634200	TOGGLE SWITCH
4	4	640302	BOOT-TOGGLE SWITCH
5	10	005001	SCREW PN HD #8 X 3/4
6	2	005101	SCREW PN HD #8 X 1 1/4
7	1	633801	CABLE ADAPTER
8	26 FT	800630	CONDUCTOR CABLE
9	2	634401	TY-RAP CABLE TIE
10	4	636600	JUMPER
11	10	000101	TERMINALS T & B
12	4	675271	NUT
13	4	642100	O-RING
14	3	019700	WASHER SP LK #8
15	21 IN	800580	3/4 WIDE OKONITE RUBBER TAPE
16	1	004700	SCREW PN HD #8 X 1 1/2
17	4	622346	CONDUCTOR ASSY 2 1/8
18	3	622347	CONDUTCOR ASSY 3 1/8
19	1	635301	TERMINAL STRIP

PENDANT ASSEMBLY 3 FUNCTION REMOVABLE

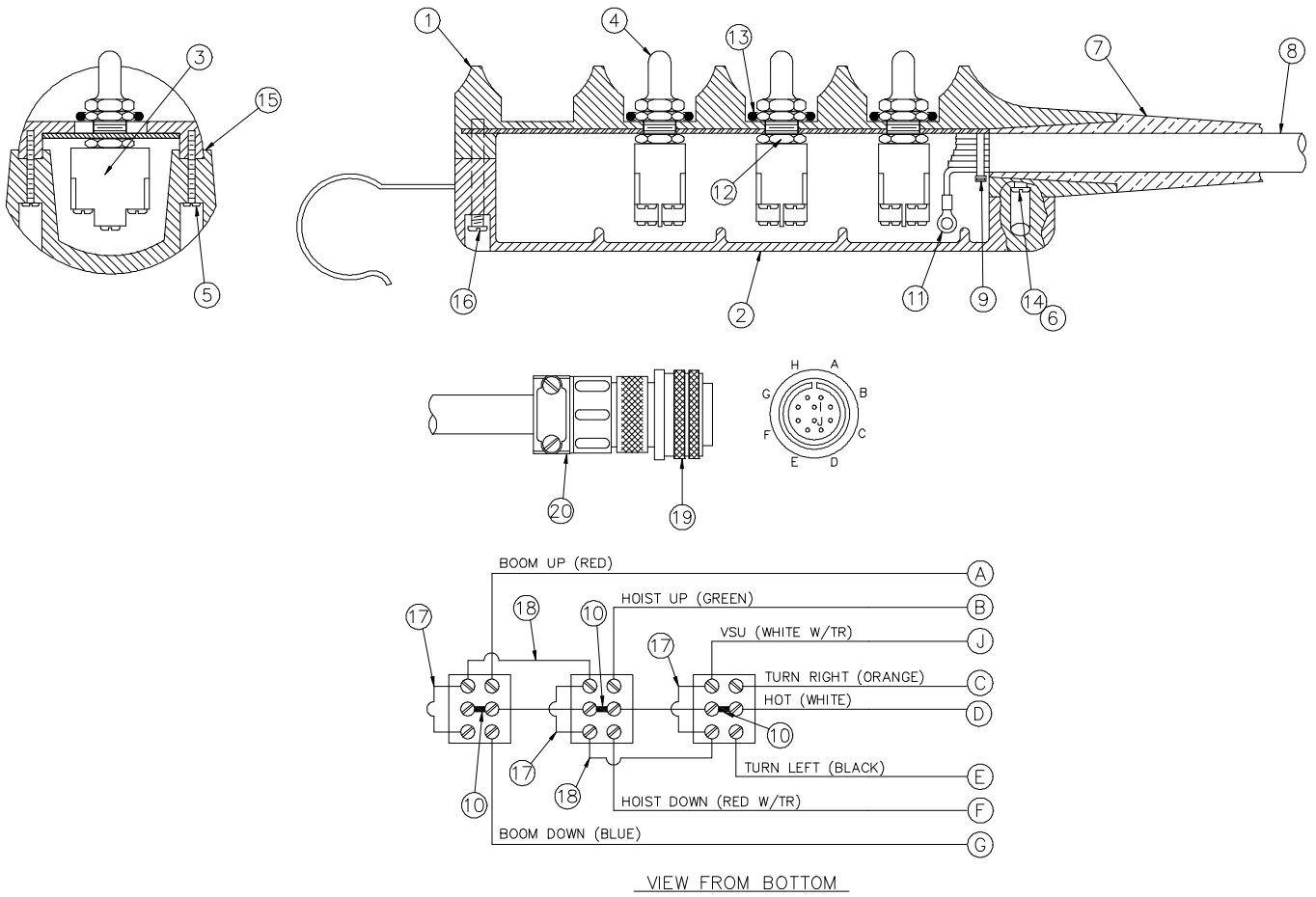

PENDANT ASSEMBLY 3 FUNCTION REMOVABLE

<u>ITEM</u>	<u>QTY</u>	<u>P/N</u>	<u>DESCRIPTION</u>
1	1	631602	PENDANT HOUSING
2	1	631700	BOTTOM COVER
3	3	634200	TOGGLE SWITCH
4	3	640302	BOOT-TOGGLE SWITCH
5	10	005001	SCREW PN HD #8 X 3/4
6	2	005101	SCREW PN HD #8 X 1 1/4
7	1	633801	CABLE ADAPTER
8	23 FT	800630	CONDUCTOR CABLE
9	2	634401	TY-RAP CABLE TIE
10	3	636600	JUMPER
11	8	000101	TERMINALS T & B
12	3	675271	NUT
13	3	642100	O-RING
14	3	019700	WASHER SP LK #8
15	21 IN	800580	3/4 WIDE OKONITE RUBBER TAPE
16	1	004700	SCREW PN HD #8 X 1 1/2
17	3	622346	CONDUCTOR ASSY 2 1/8
18	2	622347	CONDUTCOR ASSY 3 1/8
19	1	300411	PLUG ELECTRICAL
20	1	300412	CABLE CLAMP

PENDANT ASSEMBLY 4 FUNCTION REMOVABLE

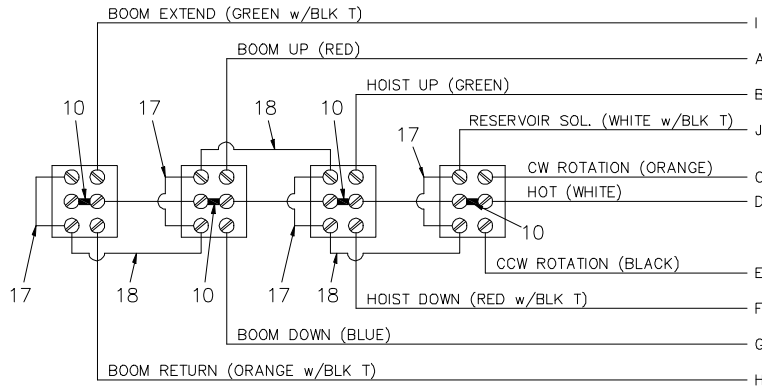
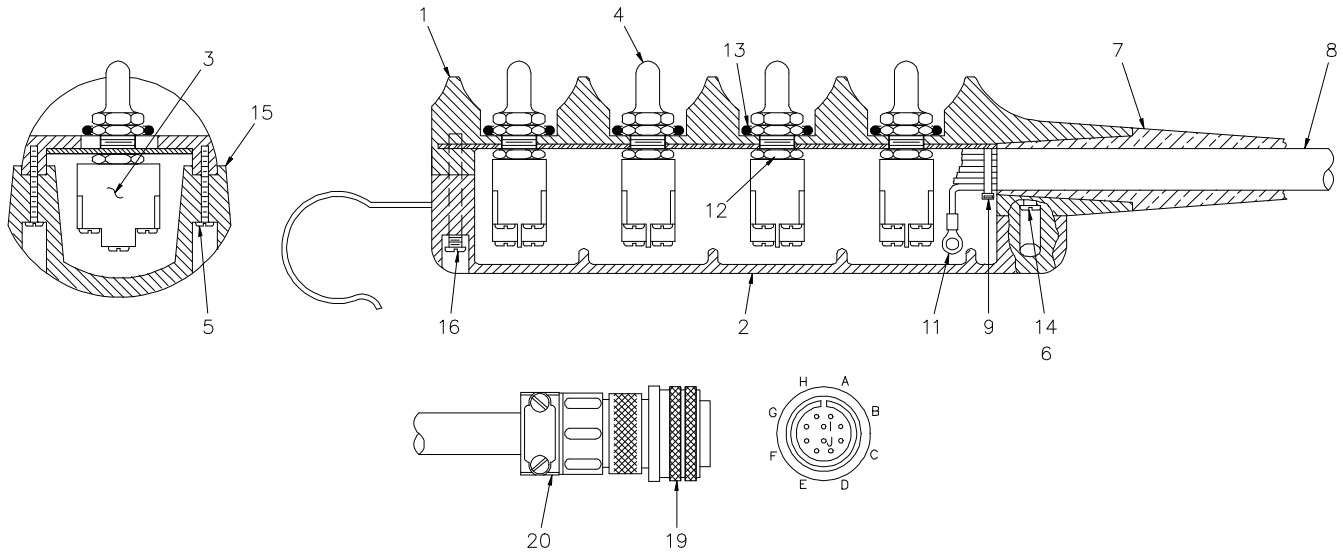

VIEW FROM BOTTOM

PENDANT ASSEMBLY 4 FUNCTION REMOVABLE

<u>ITEM</u>	<u>QTY</u>	<u>P/N</u>	<u>DESCRIPTION</u>
1	1	631601	PENDANT HOUSING
2	1	631700	BOTTOM COVER
3	4	634200	TOGGLE SWITCH
4	4	640302	BOOT-TOGGLE SWITCH
5	10	005001	SCREW PN HD #8 X 3/4
6	2	005101	SCREW PN HD #8 X 1 1/4
7	1	633801	CABLE ADAPTER
8	27 FT	800630	CONDUCTOR CABLE
9	2	634401	TY-RAP CABLE TIE
10	4	636600	JUMPER
11	10	000101	TERMINALS T & B
12	4	675271	NUT
13	4	642100	O-RING
14	4	019700	WASHER SP LK #8
15	21 IN	800580	3/4 WIDE OKONITE RUBBER TAPE
16	1	004700	SCREW PN HD #8 X 1 1/2
17	4	622346	CONDUCTOR ASSY 2 1/8
18	3	622347	CONDUTCOR ASSY 3 1/8
19	1	300411	PLUG ELECTRICAL
20	1	300412	CABLE CLAMP

PENDANT ASSEMBLY 220/24V A/W-243045 & A/W-642420

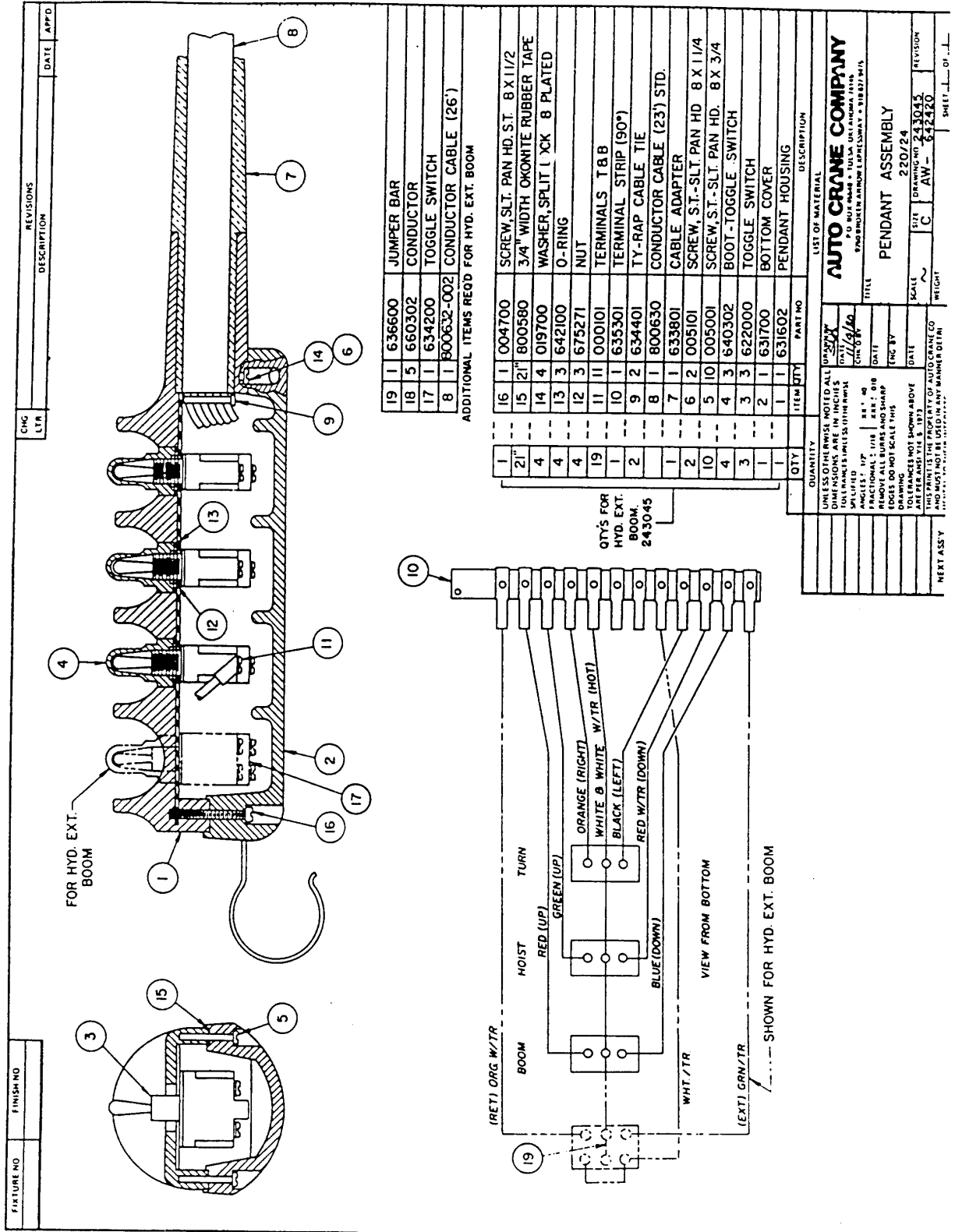

19	1	636600	JUMPER BAR
18	5	660302	CONDUCTOR
17	1	634200	TOGGLE SWITCH
8	1	800632-002	CONDUCTOR CABLE (26')

ADDITIONAL ITEMS REQD FOR HYD. EXT. BOOM

16	1	004700	SCREW, SLT. PAN HD. S.T. 8 X 1 1/2
15	2	1" 800580	3/4" WIDTH OKONITE RUBBER TAPE
14	4	019700	WASHER, SPLIT LOCK 8 PLATED
13	3	642100	O-RING
12	3	675271	NUT
11	11	000101	TERMINALS T & B
10	1	635301	TERMINAL STRIP (90°)
9	2	634401	TY-RAP CABLE TIE
8	1	800630	CONDUCTOR CABLE (23') STD.
7	1	633801	CABLE ADAPTER
6	2	005101	SCREW, S.T.-SLT. PAN HD 8 X 1 1/4
5	10	005001	SCREW, S.T.-SLT. PAN HD. 8 X 3/4
4	3	640302	BOOT-TOGGLE SWITCH
3	3	622000	TOGGLE SWITCH
2	1	631700	BOTTOM COVER
1	1	631602	PENDANT HOUSING

QUANTITY	ITEM	PART NO.	DESCRIPTION
1	1	631602	PENDANT HOUSING
1	1	631700	BOTTOM COVER
3	3	622000	TOGGLE SWITCH
4	3	640302	BOOT-TOGGLE SWITCH
10	10	005001	SCREW, S.T.-SLT. PAN HD. 8 X 3/4
2	2	005101	SCREW, S.T.-SLT. PAN HD 8 X 1 1/4
1	1	633801	CABLE ADAPTER
8	1	800630	CONDUCTOR CABLE (23') STD.
2	2	634401	TY-RAP CABLE TIE
1	1	635301	TERMINAL STRIP (90°)
11	11	000101	TERMINALS T & B
4	4	642100	O-RING
4	4	019700	WASHER, SPLIT LOCK 8 PLATED
2	2	1" 800580	3/4" WIDTH OKONITE RUBBER TAPE
1	1	004700	SCREW, SLT. PAN HD. S.T. 8 X 1 1/2

UNLESS OTHERWISE NOTED ALL DIMENSIONS ARE IN INCHES
TOLERANCES UNLESS OTHERWISE SPECIFIED
FRACTIONAL: 1/16 .0015 .015
REMOVE ALL BURRS AND SHARP EDGES DO NOT SCALE THIS DRAWING
TOLERANCES NOT SHOWN ABOVE ARE PER ANSI Y14.5 1973
THIS PART IS THE PROPERTY OF AUTOCRANE CO.
IT IS TO BE RETURNED TO THE COMPANY FROM WHICH IT WAS PURCHASED.
NEXT ASSY

LIST OF MATERIAL

AUTO CRANE COMPANY
2000 W. 12TH AVE., SUITE 100
DENVER, COLORADO 80202

PENDANT ASSEMBLY
220/24V
AW-243045

SCALE: _____
DATE: _____
REVISION: _____

SHEET _____ OF _____

REMOVABLE PENDANT KIT 6006 SERIES

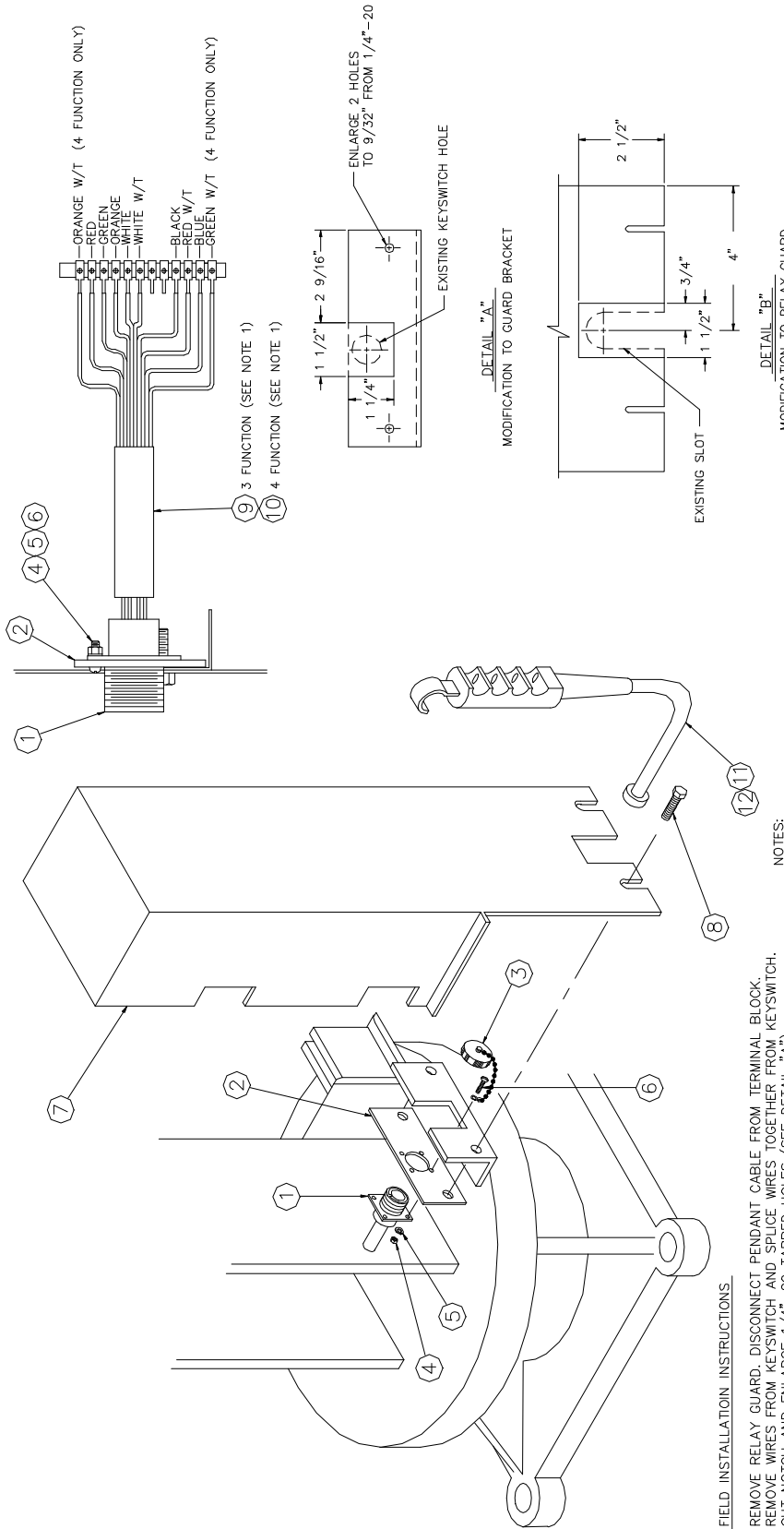

FIELD INSTALLATION INSTRUCTIONS

1. REMOVE RELAY GUARD. DISCONNECT PENDANT CABLE FROM TERMINAL BLOCK.
2. REMOVE WIRES FROM KEYSWITCH AND SPLICE WIRES TOGETHER FROM KEYSWITCH. CUT NOTCH AND ENLARGE 1/4"-20 TAPPED HOLES (SEE DETAIL "A").
3. ENLARGE KEYSWITCH SLOT IN RELAY GUARD (SEE DETAIL "B").
4. ATTACH TERMINAL STRIP OF PENDANT CONDUCTOR ASSEMBLY (ITEM 9 OR 10) TO TERMINAL BLOCK OF RELAY PANEL (SEE AW-676105).
5. ATTACH CONDUCTOR AND MOUNTING PLATE TO GUARD BRACKET WITH (2) 1/4"-20 UNC X 3/4" SCREWS. LEAVE SCREWS LOOSE ENOUGH FOR THICKNESS OF RELAY GUARD TO FIT BETWEEN HEAD OF SCREWS AND GUARD BRACKET.
6. INSTALL RELAY GUARD AND TIGHTEN SCREWS.
7. ATTACH PENDANT.

NOTES:

1. FOR ADDITIONAL WIRING INFORMATION SEE AW-676105 AND AW-630912.
2. FOR 3 FUNCTION REMOVABLE PENDANT KIT, ORDER PART NUMBER 330665
3. FOR 4 FUNCTION, (POWER EXTENSION), REMOVABLE PENDANT KIT ORDER PART NUMBER 330669
4. ITEMS 9, AND 10, REMOVABLE PENDANT CONDUCTOR ASSEMBLIES, COME WITH ITEMS 1 THROUGH 6.

REMOVABLE PENDANT KIT ***6006 SERIES***

<u>ITEM</u>	<u>QTY</u>	<u>P/N</u>	<u>DESCRIPTION</u>
1	1	300410	RECEPTACLE FEMALE 10 PIN
2	1	330661	RECEPTACLE MOUNT PLATE
3	1	300413	CAP RECEPTACLE
4	2	015400	NUT HX #6-32
5	2	019600	WASHER SP LK #6
6	2	000603	SCREW RD HD #6-32 X 1/2
7	1	330660	GUARD RELAY PANEL
8	2	REF	SCREW HX 1/4 X 3/4
9	1	330662	REMOVABLE PENDANT CONDUCTOR ASSY (3 FUNCTION)
10	1	330663	REMOVABLE PENDANT CONDUCTOR ASSY (4 FUNCTION)
11	1	480400	PENDANT ASSY (3 FUNCTION REMOVABLE)
12	1	480800	PENDANT ASSY (4 FUNCTION REMOVABLE)

LOAD LIMIT SWITCH ASSEMBLY 6006 SERIES

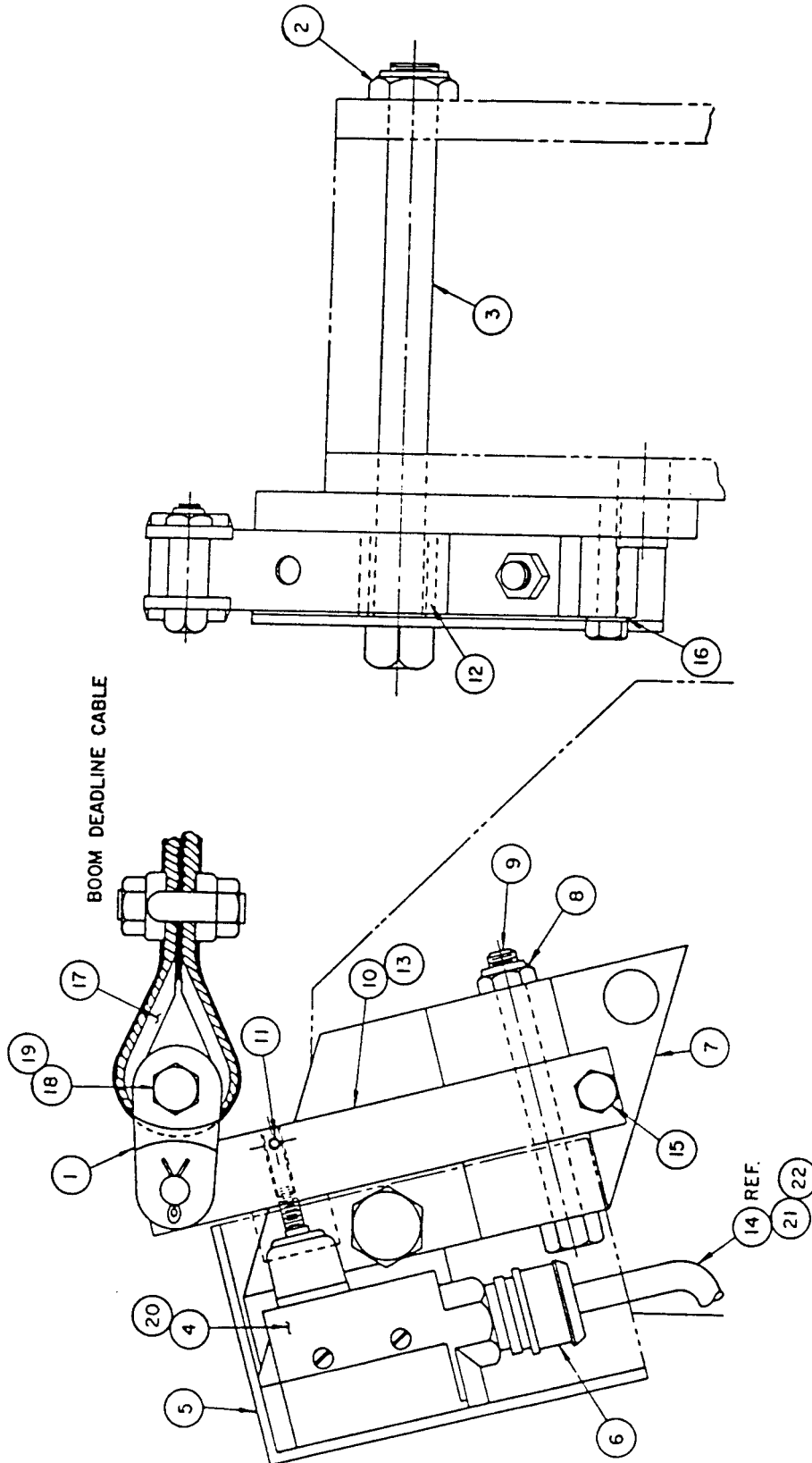

LOAD LIMIT SWITCH ASSEMBLY

6006 SERIES

<u>ITEM</u>	<u>QTY</u>	<u>P/N</u>	<u>DESCRIPTION</u>
1	1	100801	CLEVIS
2	1	REF	NUT HALF LK 5/8 NF (018100)
3	1	REF	SCREW 5/8 NF X 7 1/2 (013301)
4	1	646900	SWITCH
5	1	241147	GUARD
6	1	642908	CLAMP
7	1	241105	BRACKET
8	2	017400	NUT HALF LK 3/8 NF
9	1	009800	SCREW 3/8 NF X 3 1/2
10	1	650205	SENSING ARM
11	1	023700	PIN ROLL 1/8 X 3/4
12	1	646700	SPACER
13	1	002905	SENSING ARM SCREW
14	1	REF	CONDUCTOR (655636)
15	1	005702	SCREW HX HD 1/4-28 X 1 1/2
16	1	020200	WASHER LK 1/4
17	1	023600	THIMBLE 5/16 WIRE ROPE
18	1	017400	NUT HALF LK 3/8-24
19	1	009100	SCREW HX HD 3/8-24 X 1 1/2
20	2	000101	TERM WIRE
21	1	000302	TERM WIRE
22	1	000300	TERM WIRE

SWING LIMIT SENSOR ASSEMBLY 6006 SERIES

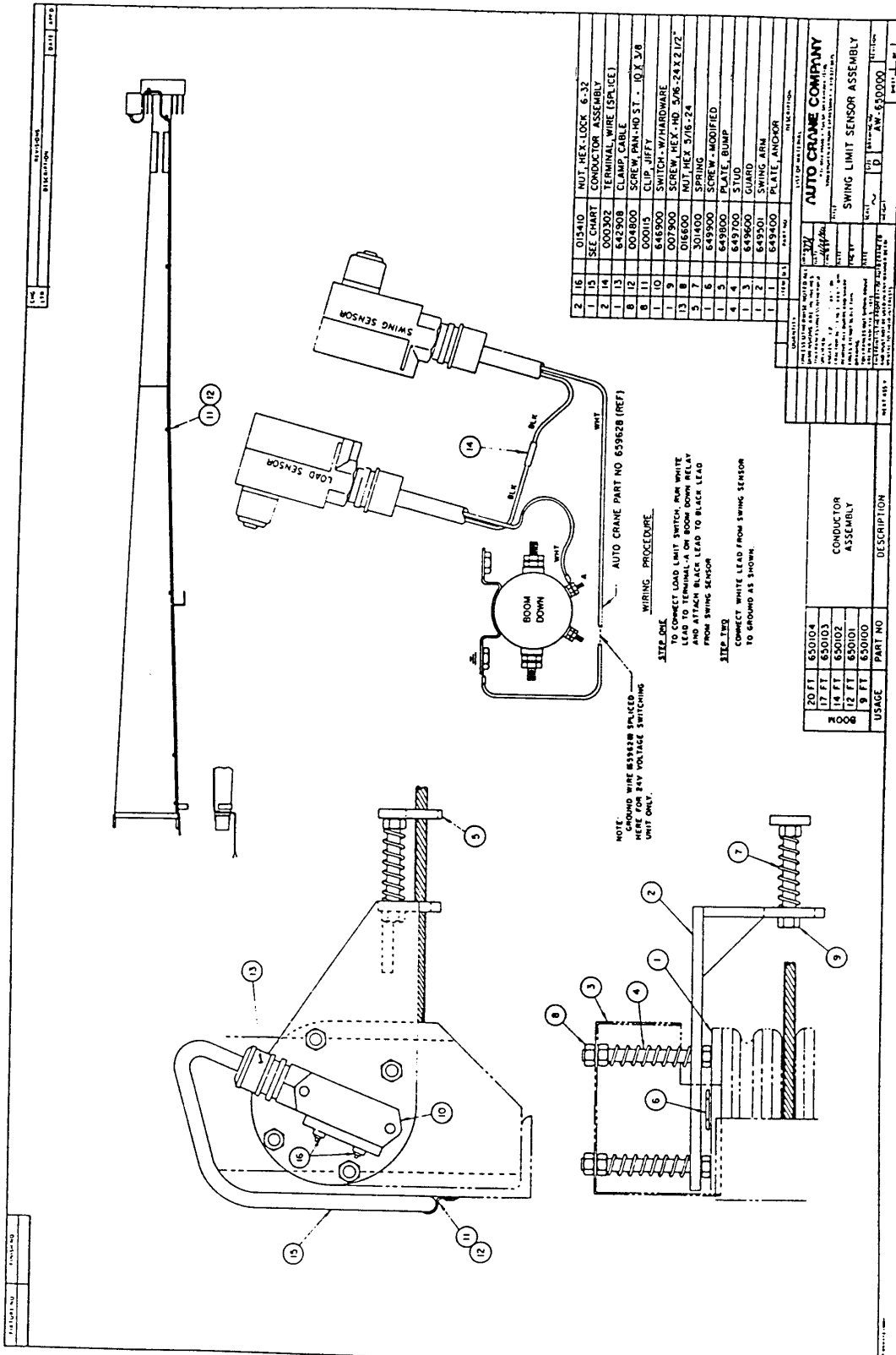

ELECTRIC MOTOR 6006 SERIES

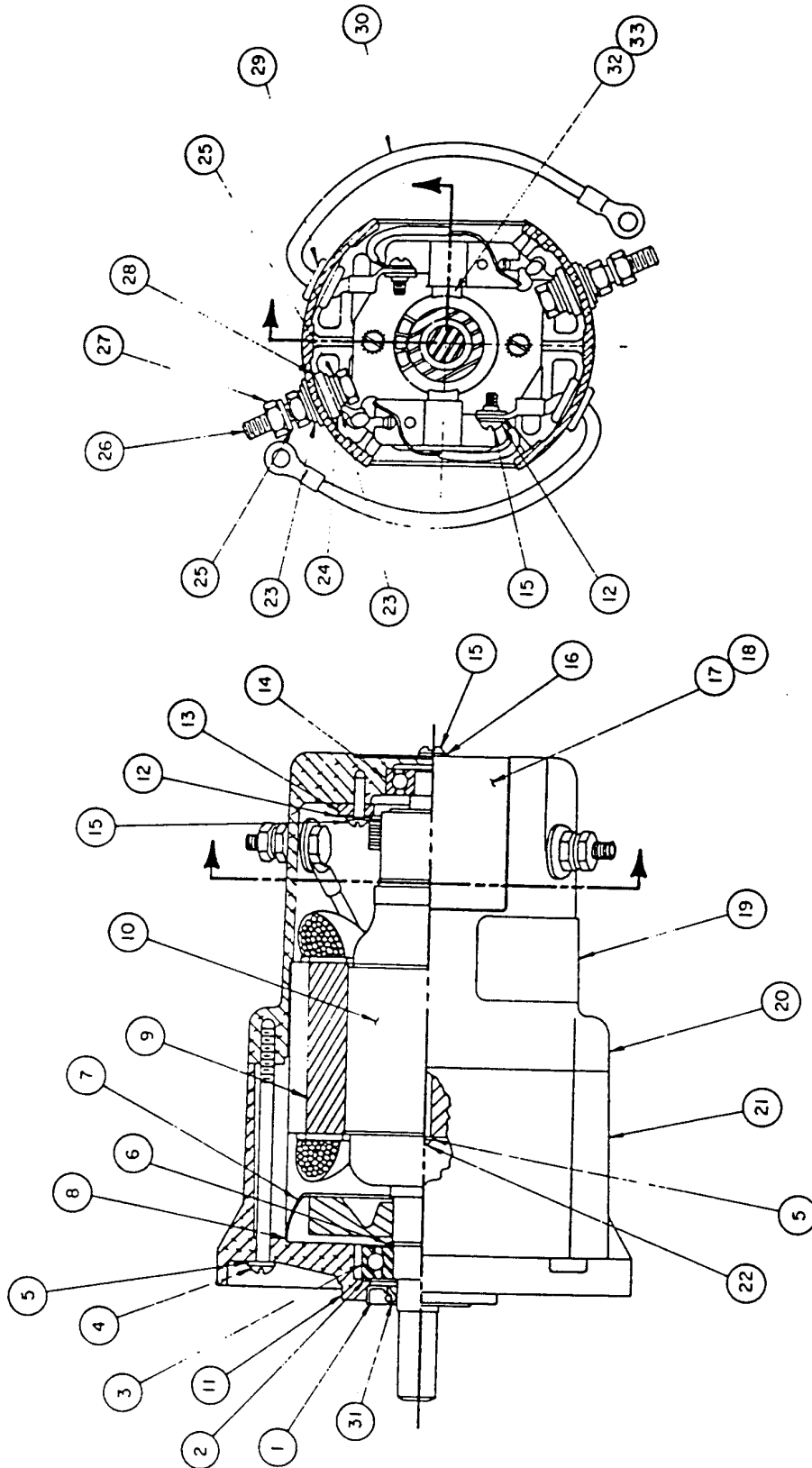

DUMORE

ELECTRIC MOTOR 6006 SERIES

ITEM	QTY.	PART NO.	DESCRIPTION
1	1	300174	SEAL
2	1	300251	SPRING, FLAT
3	1	300252	BALL BEARING
4	2	300253	SCREW, #10 X 3-1/8
5	4	300254	LOCKWASHER
6	1	300255	RETAINING RING
7	1	300256	BAFFLE
8		(REF)	LOCTITE 404
9	1	300257	FIELD ASSEMBLY
10	1	(REF)	ARMATURE ASSEMBLY
11		(REF)	SYLASTIC
12	4	300260	LOCKWASHER, EXT. TOOTH
13	1	300261	BRUSH CARD ASSY.
14	1	300262	BALL BEARING
15	6	300263	SCREW, #8 X 3/8
16	2	200264	LOCKWASHER
17	1	300265	GUARD, BRUSH
18	1	300266	INSULATOR, GUARD
19		(REF)	NAMEPLATE
20	1	300267	HOUSING, BRUSH END
21	1	300268	HOUSING, PLAIN END
22	2	300269	SCREW, #10 X 2-3/4
23	4	300270	WASHER, STEEL
24	4	300271	WASHER, PHENOLIC
25	6	300272	LOCKWASHER
26	2	300273	SCREW, 1/4 - 20
27	4	300274	NUT, 1/4 - 20
28	4	300275	WASHER, FIBER
29	2	300276	BUSHING
30	2	300277	LEAD ASSEMBLY
31		(REF)	GREASE
32	2	309100	BRUSH MOTOR
33	2	300116	SPRING, MOTOR

WHEN ORDERING MOTOR PARTS, PLEASE SPECIFY MODEL.

***ELECTRIC MOTOR 750 "S" MSX DUNMORE
6006 SERIES***

ITEM	QTY.	PART NO.	DESCRIPTION
1	1	300551	ARMATURE ASS'Y
2	1	300552	FIELD ASS'Y
3			
4	1	300554	HOUSING, BRUSH END
5	1	300555	CYL./BAFFLE ASS'Y
6	1	300556	HOUSING PLAIN END
7	1	300557	SEAL
8	1	300558	SPRING, LOADING
9	1	300559	BALL BEARING
10	2	300560	NUT,KEPS 10-32
11	1	300561	BALL BEARING
12	1	300562	COVER
13	2	300563	SPACER
14	2	300564	SCREW 8-32
15	1	300565	BRUSH CARD ASS'Y
16	2	300566	CARBON BRUSH ASS'Y
17	2	300567	SCREW, SEMS 8-32
18	2	300568	SCREW, SEMS 10-32
19	2	300569	LEAD ASSEMBLY
20	2	300570	RUBBER GROMMET
21	2	300571	STUD 10-32 X 7.5
22	1	300572	NAMEPLATE
23	2	300573	LOCKWASHER INT.

ELECTRIC MOTOR MSI (6027) 6006 SERIES

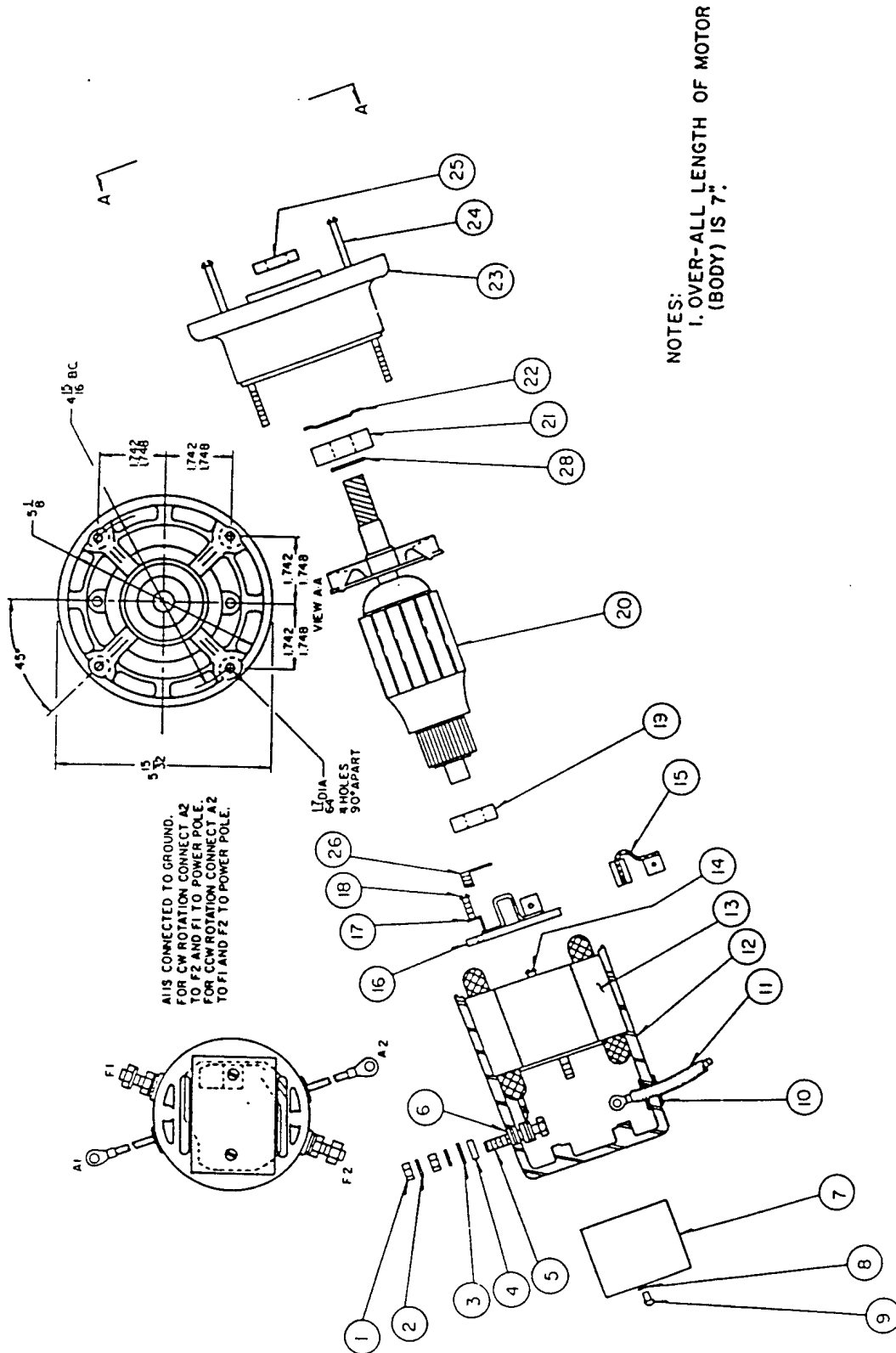

ELECTRIC MOTOR MSI (6027)
6006 SERIES

ITEM	QTY.	PART NO.	DESCRIPTION
1	4	300451	NUT
2	6	300452	WASHER, LOCK
3	4	300453	WASHER, FLAT
4	4	300454	INSULATOR, MOTOR
5	2	300455	SCREW, HEX-HD
6	6	300456	INSULATOR, MOTOR
7	1	300457	COVER, END - MOTOR
8	2	300458	WASHER, LOCK
9	2	300459	SCREW
10	2	300460	GROMMET, INSULATOR
11	2	300461	LEAD, MOTOR
12	1	300462	HOUSING, MOTOR
13	1	300463	STATOR - 12V
14	2	300464	SCREW
15	2	300465	BRUSH, MOTOR
16	1	300466	BRACKET, MOTOR
17	2	300467	WASHER, LOCK
18	2	300468	SCREW
19	1	300469	BEARING
20	1	300470	ARMATURE - 12V
21	1	300471	BEARING
22	1	300472	SPRING, MOTOR
23	1	300473	HEAD, MOTOR
24	2	300474	SCREW, MOTOR
25	1	300475	SEAL, MOTOR
26	2	300476	SPRING, MOTOR
27	1	300477	DECAL, MOTOR
28	1	300478	SHIM

MAINTENANCE INSTRUCTIONS

MOTOR BRUSHES

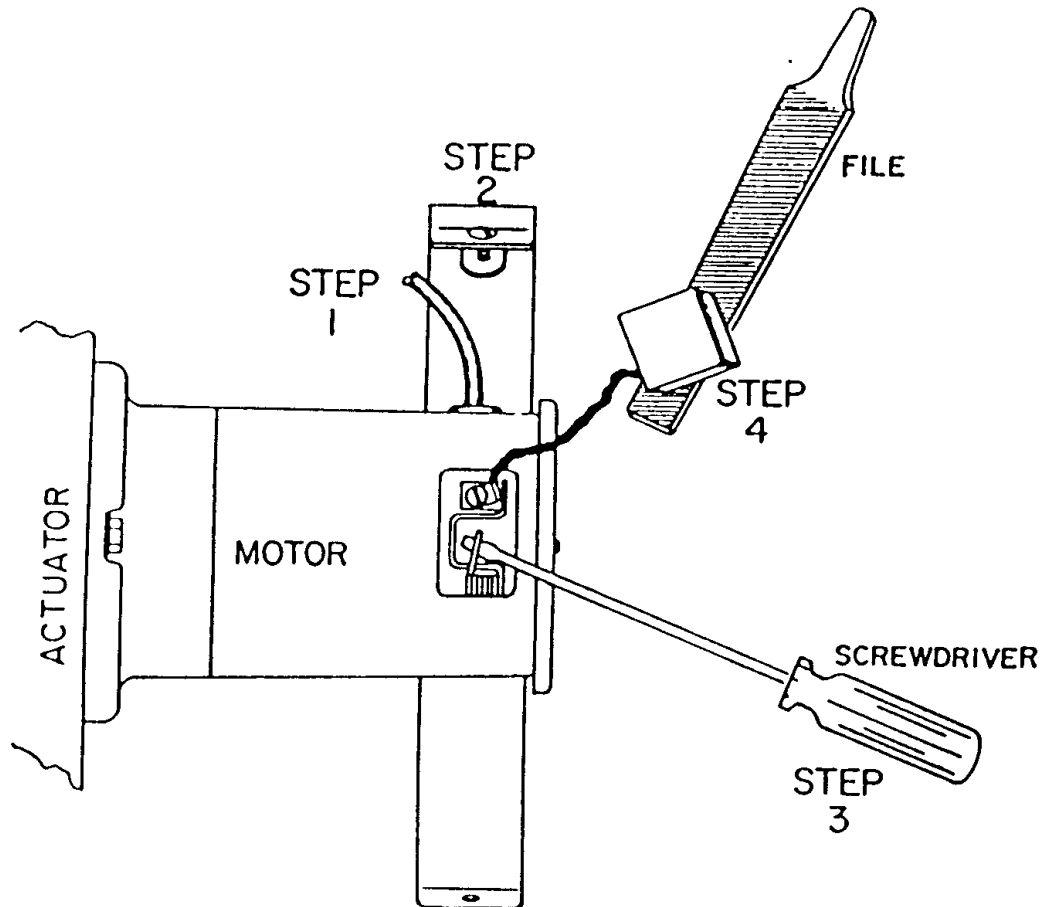

NOTE:

IF MOTOR LOSES POWER IT MAY BE BECAUSE THE BRUSHES HAVE BECOME TIGHT IN THE BRUSH HOLDER. TO CORRECT THIS CONDITION, FOLLOW THE INSTRUCTIONS BELOW:
REF. MOTOR AW-300105.

- | STEP | INSTRUCTIONS |
|------|---|
| 1. | DISCONNECT MOTOR LEADS. |
| 2. | REMOVE BAND (P/N: 300162) BY LOOSENING SCREW (P/N: 300161). |
| 3. | RAISE BRUSH SPRING (P/N: 300165) WITH SCREWDRIVER AND REMOVE BRUSHES. |
| 4. | DRESS FACE OF BRUSHES LIGHTLY WITH FILE. |

ASSEMBLE IN REVERSE SEQUENCE AND TEST.

HYDRAULIC PUMP

P/N: 330607

NOTE:

1. ITEM 9, SOLENOID VALVE IS
SOLD SEPERATELY. PART NO.
300204.

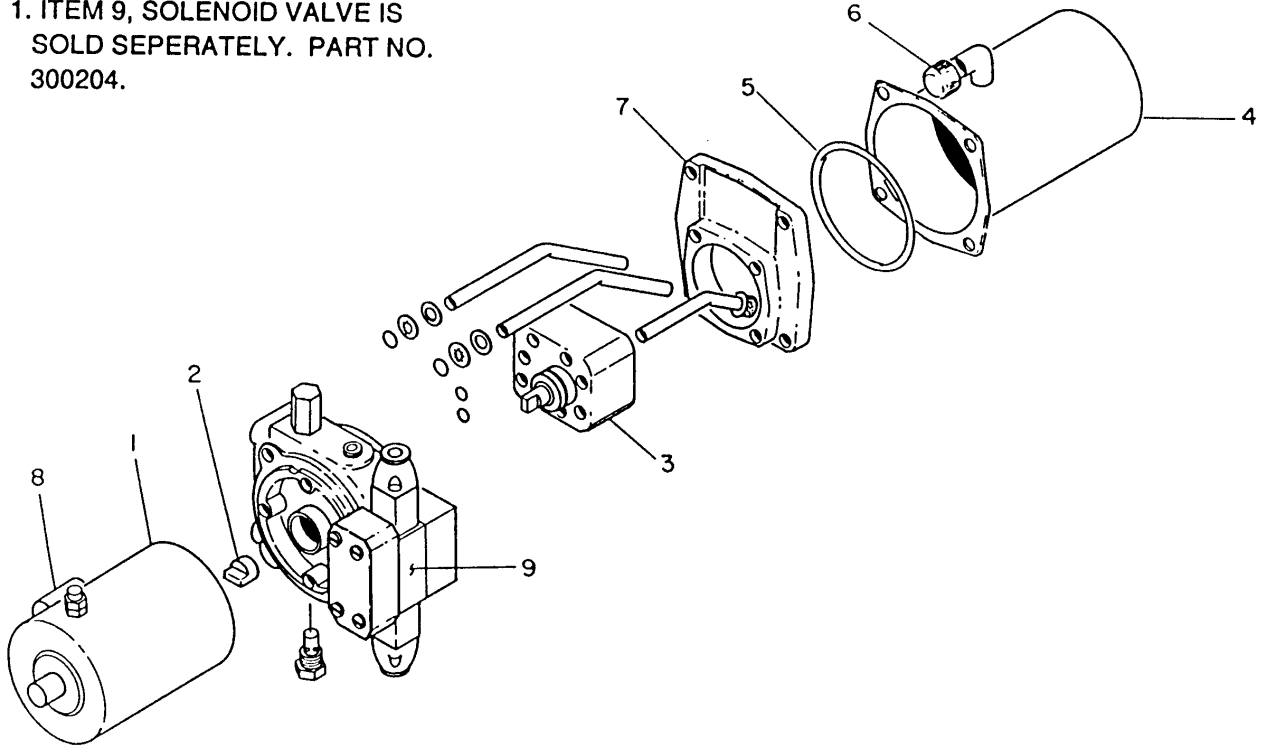

<u>ITEM</u>	<u>QTY</u>	<u>P/N</u>	<u>DESCRIPTION</u>
1	-	330625	MOTOR PUMP
2	-	330409	COUPLING
3	-	330626	PUMP KIT
4	-	330627	RESERVOIR
5	-	330628	O-RING
6	-	200545	CAP BREATHER
7	-	330629	RESERVOIR ADAPTER
8	-	330631	SOLENOID
9	-	REF	SEE NOTE #1

HYDRAULIC PUMP

P/N: 330608

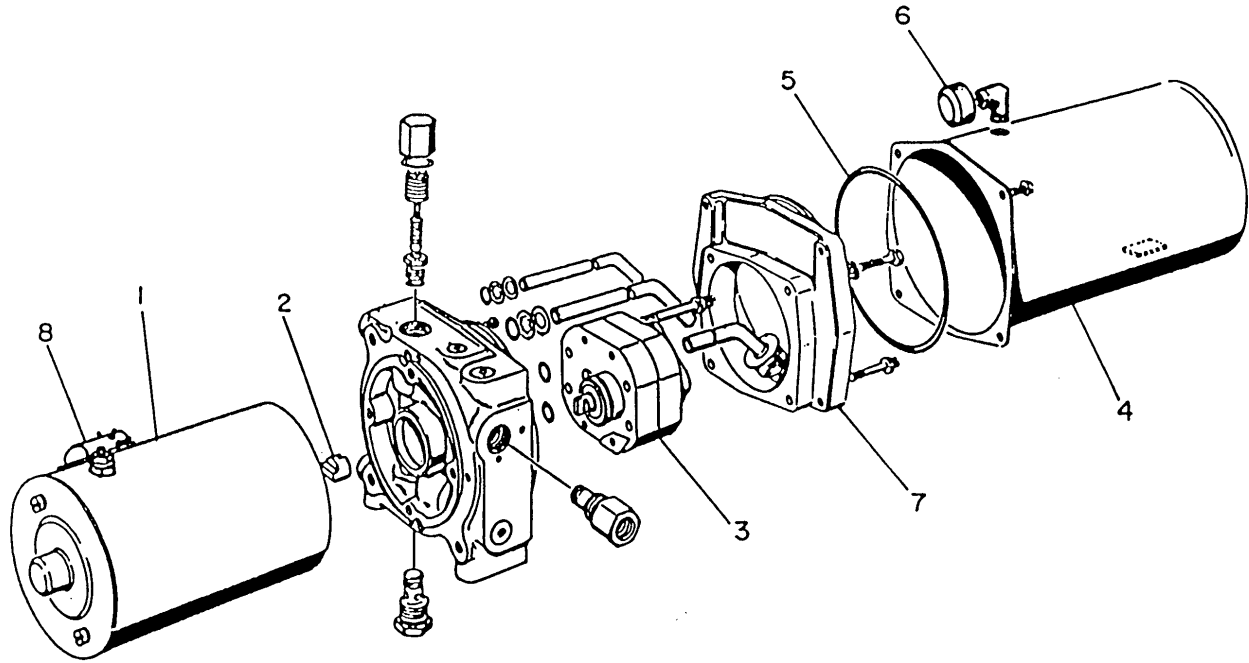

<u>ITEM</u>	<u>QTY</u>	<u>P/N</u>	<u>DESCRIPTION</u>
1	-	330625	MOTOR PUMP
2	-	330409	COUPLING
3	-	330626	PUMP KIT
4	-	330627	RESERVOIR
5	-	330628	O-RING
6	-	200545	CAP BREATHER
7	-	330629	RESERVOIR ADAPTER
8	-	330631	SOLENOID

JACKLEG ASSEMBLY

P/N 200745

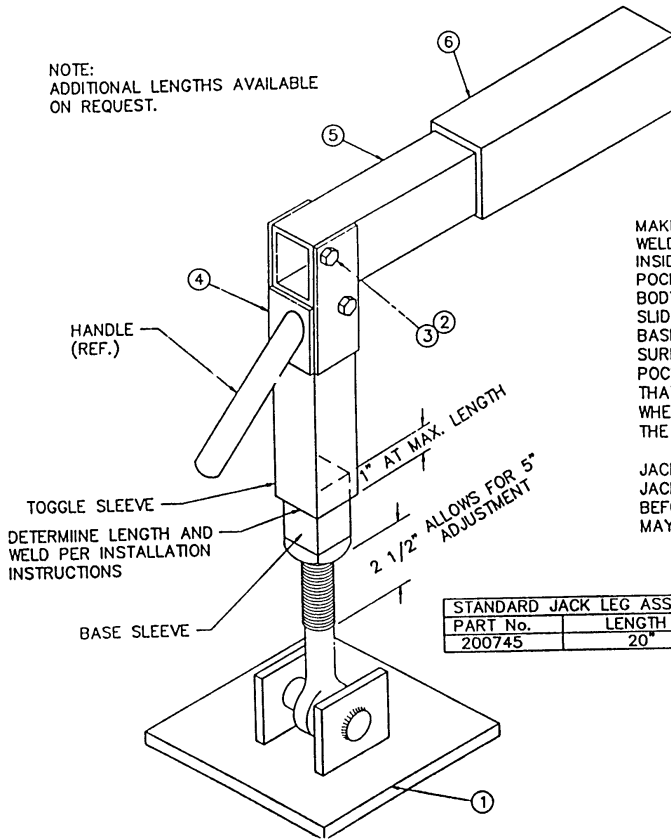

NOTE:
ADDITIONAL LENGTHS AVAILABLE
ON REQUEST.

INSTALLATION INSTRUCTIONS (JACKLEG)
 MAKE SURE TRUCK IS PARKED ON LEVEL SURFACE.
 WELD POCKET (Item 6) TO TRUCK BODY AT REAR JUST
 INSIDE BUMPER, OR DESIRABLE LOCATION. END OF
 POCKET SHOULD BE FLUSH WITH OUTSIDE OF THE TRUCK
 BODY. BE SURE THE POCKET IS WELDED SECURELY. NEXT,
 SLIDE HORIZONTAL MEMBER (Item 5) INTO POCKET. SLIDE
 BASE ASSEMBLY (Item 1) INTO TOGGLE SLEEVE. MAKE
 SURE LEG ASSEMBLY IS VERTICAL & FULLY INSERTED IN
 POCKET. NOW BASE SCREW SHOULD BE ADJUSTED SO
 THAT 2 1/2" OF THREAD IS EXPOSED. MARK BASE SLEEVE
 WHERE TOGGLE SLEEVE ENDS. PULL JACK LEG OUT OF
 THE POCKET & WELD (Ref. 3/16") ALL AROUND AT MARK.

JACK LEG IS READY FOR USE. UPON USE, MAKE SURE
 JACK LEG HAS ADEQUATE TENSION (SELF-DETERMINING),
 BEFORE SELF-LOCKING IN PLACE. ADJUSTMENT OF SCREW
 MAY BE NEEDED DEPENDING ON GROUND SURFACE.

STANDARD JACK LEG ASS'Y	
PART No.	LENGTH
200745	20"

ITEM	QTY	P/N	DESCRIPTION
1	1	200041	BASE ASSEMBLY
2	2	017800	LOCKNUT HX 1/2 NF
3	2	006801	CAPSCREW HX HD 1/2 NF x 4
4	1	200085	TOGGLE
5	1	200081	HORIZONTAL MEMBER
6	1	700047	POCKET TUBE

GUARD ASSEMBLY 24 V

P/N 306000-1

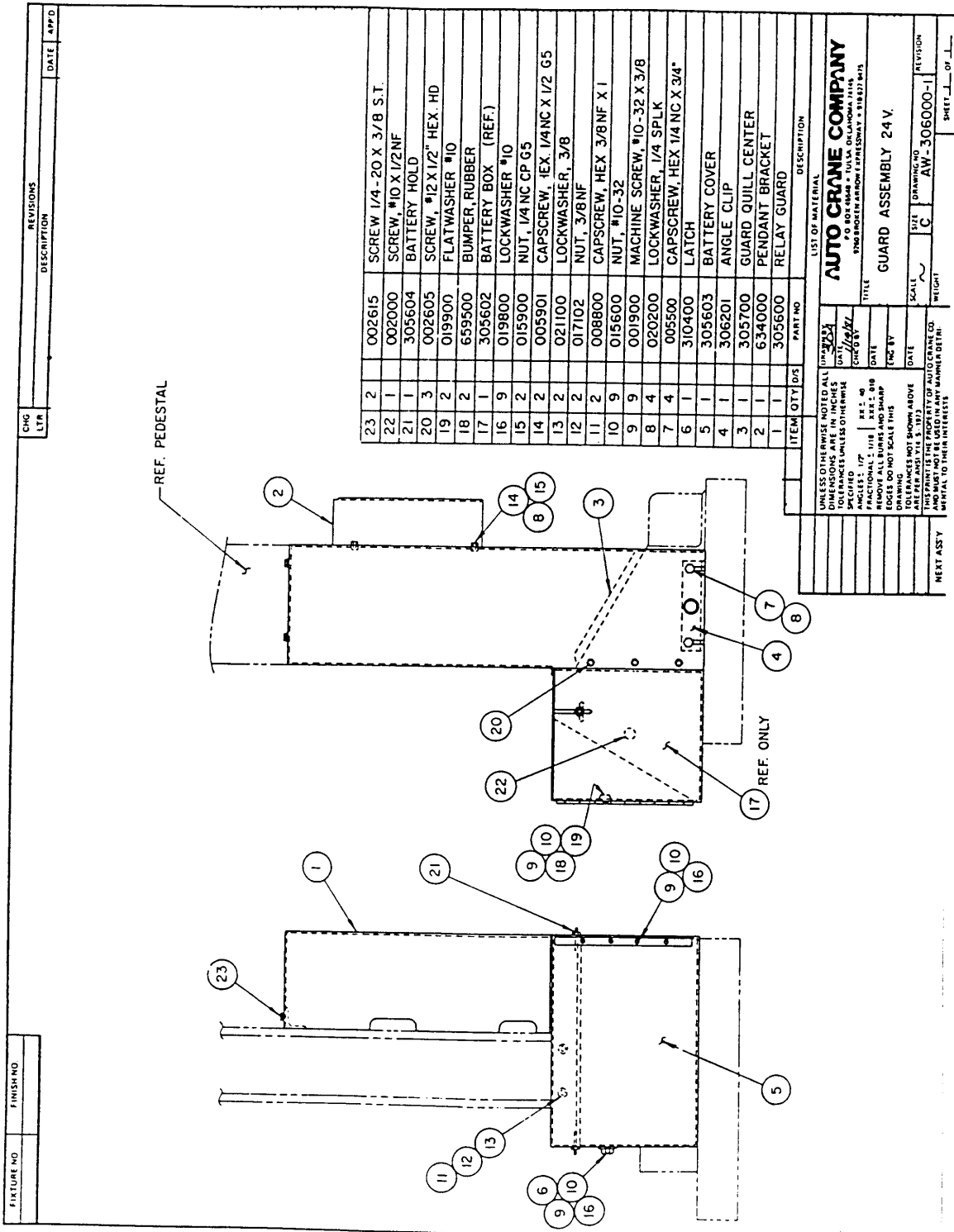

REVISIONS		DATE	APP'D
CHG	DESCRIPTION		
LTR			

LIST OF MATERIAL	
UNLESS OTHERWISE NOTED ALL DIMENSIONS ARE IN INCHES	UNLESS OTHERWISE NOTED ALL DIMENSIONS ARE IN INCHES
SPALLS ARE TO BE REMOVED UNLESS OTHERWISE SPECIFIED	SPALLS ARE TO BE REMOVED UNLESS OTHERWISE SPECIFIED
ANGLES: 1/7	ANGLES: 1/7
FRACTIONAL: 1/16	FRACTIONAL: 1/16
EDGES: 1/8" RADIUS	EDGES: 1/8" RADIUS
SHARP EDGES: 1/8" RADIUS	SHARP EDGES: 1/8" RADIUS
ALL DIMENSIONS NOT SHOWN ABOVE ARE TO BE TAKEN FROM THIS DRAWING	ALL DIMENSIONS NOT SHOWN ABOVE ARE TO BE TAKEN FROM THIS DRAWING
THIS PRINT IS THE PROPERTY OF AUTO CRANE CO. AND MUST NOT BE USED IN ANY MANNER DETRIMENTAL TO THEIR INTERESTS.	THIS PRINT IS THE PROPERTY OF AUTO CRANE CO. AND MUST NOT BE USED IN ANY MANNER DETRIMENTAL TO THEIR INTERESTS.

TITLE	GUARD ASSEMBLY 24 V.
SCALE	C
DRAWING NO	AW-306000-1
REVISION	
SHEET	1 OF 1

CABLE GUIDE ASSEMBLY

P/N 240263

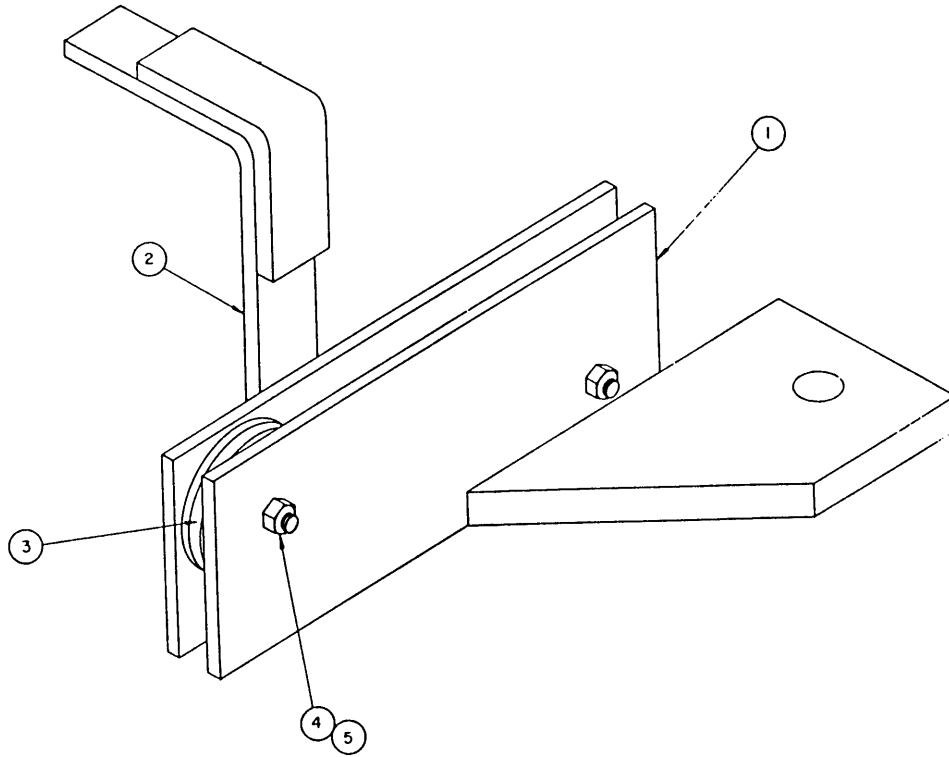

<u>ITEM</u>	<u>QTY</u>	<u>P/N</u>	<u>DESCRIPTION</u>
1	1	240264	SHEAVE PLATE
2	1	240265	SHEAVE PLATE
3	2	200910	SHEAVE ASSEMBLY
4	2	009108	SCREW HX HD 3/8 x 1 1/4
5	2	017400	NUT HX HALF LK 3/8

6006 LOAD CHART

P/N 040611

CHG LTR	REVISIONS	DATE	APP'D
DESCRIPTION			
	ITEM	QTY	D/S
			PART NO.
	DESCRIPTION		
LIST OF MATERIAL			
AUTO CRANE COMPANY			
P.O. BOX 580697 • TULSA, OKLAHOMA 74158-0697 4707 NORTH MINGO ROAD • 918-836-0463			
TITLE LOAD CHART			
DRAWN BY		SCALE	
DATE		SIZE	
CHK'D BY		DRAWING NO.	
DATE		REVISION	
ENG. BY		WEIGHT	
DATE		SHEET	
		OF	
UNLESS OTHERWISE NOTED ALL DIMENSIONS ARE IN INCHES. TOLERANCES UNLESS OTHERWISE SPECIFIED. ANGLES ± .1/2° .XX ± .040 FRACTIONAL ± 1/16 .XXX ± .010 REMOVE ALL BURRS AND SHARP EDGES. DO NOT SCALE THIS DRAWING. TOLERANCES NOT SHOWN ABOVE ARE PER ANSI Y14.5-1973 THIS PRINT IS THE PROPERTY OF AUTO CRANE CO. AND MUST NOT BE USED IN ANY MANNER DETRIMENTAL TO THEIR INTERESTS.			
NEXT ASS'Y			



AUTO CRANE COMPANY

P. O. BOX 581510 • TULSA, OKLAHOMA 74158

Limited Warranty

Auto Crane will warranty to consumer for a period of twelve months from date of purchase that each new Auto Crane product it sells will be free under normal use and service, from defects in material and workmanship. Date of purchase will be honored as either date of purchase by distributor or his date of sale of the product as substantiated by Distributor Delivery Report.

Obligation of Auto Crane under this warranty is limited to replacement or repair of parts that appear to manufacturer after review and / or inspection to be defective. This warranty does not obligate Auto Crane to bear the cost of labor or transportation charges in connection with the replacement or repair of defective parts. Responsibility for customer's claims arising from misapplication, abuse, misuse or alteration of equipment or parts lies with the distributor or user and no warranty obligation is assumed in the circumstances by Auto Crane.

Auto Crane will in no event be liable for any consequential damages or contingent liabilities arising out of the failure of any Auto Crane product or parts to operate properly.

Auto Crane makes no warranty in respect to component accessories, same being subject to the warranties of their respective manufacturers.

If field service, at the request of buyer, is rendered and fault is found not to be with Auto Crane's product, the buyer shall pay the time and expense of the field representative. Claims for service labor or other expenses that have been incurred by the buyer without approval or authorization of Auto Crane will not be accepted.

AUTO CRANE COMPANY IS UNDER NO OBLIGATION TO EXTEND THIS WARRANTY TO ANY CUSTOMER FOR WHICH AN AUTO CRANE WARRANTY REGISTRATION CARD HAS NOT BEEN COMPLETED AND MAILED TO AUTO CRANE COMPANY WITHIN FIFTEEN (15) DAYS AFTER DATE OF PURCHASE.