

# **OWNERS MANUAL**

## **6006H**

**REVISION 2/2000**

PART NO. 999945

**SERIAL NO.** \_\_\_\_\_

# **AUTO CRANE COMPANY**

PO BOX 580697, TULSA, OK 74158-0697

4707 N. MINGO ROAD, TULSA, OK 74117-5904

PHONE (918) 836-0463

SALES FAX (918) 438-6688    SERVICE FAX (918) 834-5979

**!! DISTRIBUTORS !!**

**PROTECT YOUR CUSTOMER'S WARRANTY!  
SUBMIT DELIVERY REPORT WITHIN 15 DAYS.**

Mail to: Auto Crane Company  
P.O. Box 580697  
Tulsa, OK 74158-0697

Or Fax to: 918/834-5979

Protect your customers warranty - Submit within 15 days from delivery date.



**AUTO CRANE COMPANY**

**DISTRIBUTOR  
DELIVERY REPORT**

DISTRIBUTOR _____		OWNER _____	
ADDRESS _____		CITY/STATE _____	
CITY/STATE/ZIP _____		BUSINESS _____	
MODEL #	SERIAL #	DATE DELIVERED	UNIT DESTINATION

**IMPORTANT: ATTACH SIGNED COPY OF CUSTOMER INVOICE / DELIVERY RECEIPT**

AC-109 REPORT AUTHORIZED BY: \_\_\_\_\_

**\* REGISTER ONE UNIT ONLY PER CARD \***

# ***WARNINGS - READ THIS PAGE!***

**WARNING!** Federal law (49 cfr part 571) requires that the Final Stage Manufacturer of a vehicle certify that the vehicle complies with all applicable federal regulations. Any modifications performed on the vehicle prior to the final stage are also considered intermediate stage manufacturing and must be certified as to compliance. The installer of this crane and body is considered one of the manufacturers of the vehicle. As such a manufacturer, the installer is responsible for compliance with all applicable federal and state regulations, and is required to certify that the vehicle is in compliance.

**WARNING!** It is the further responsibility of the installer to comply with the OSHA Truck Crane Stability Requirements as specified by 29 CFR part 1910.180 (C) (1).

**WARNING! NEVER OPERATE THE CRANE NEAR ELECTRICAL POWER LINES!** Death or serious injury will result from boom, line, or load contacting electric lines. Do not use crane within 10 feet (3.05m) of electric power lines carrying up to 50,000 volts. One foot additional clearance is required for every additional 30,000 volts or less.

**WARNING! NEVER .....**

- v **EXCEED** load chart capacities (centerline of rotation to hoist hook).
- v un-reel last 5 wraps of cable from drum!
- v wrap cable around load!
- v attempt to lift or drag a load from the side! The boom can fail far below its rated capacity.
- v weld, modify, or use unauthorized components on any Auto Crane unit! This will void any warranty or liability. Also failure of the crane may result.
- v place a chain link on the tip of the hook and try to lift a load!
- v use a sling bar or anything larger than the hook throat that could prevent the hook latch from closing, thus negating the safety feature!
- v hold on any pendant Select Switch that will cause unsafe operating conditions!

**WARNING!** In using a hook with latch, **ALWAYS** make sure that the hook throat is closed before lifting a load! Proper attention and common sense applied to the use of the hoist hook and various slings will prevent possible damage to material being hoisted and may prevent injury to personnel.

**WARNING!** Failure to correctly plumb and wire crane can cause inadvertent operation and damage to crane and/or personnel!

**WARNING!** Auto Crane Company remote controlled cranes are not designed or intended to be used for any applications involving the lifting or moving of personnel.

**WARNING!** **ALWAYS** operate the crane in compliance with the load capacity chart. **Do not use** the overload shutdown device to determine maximum rated loads, if your crane is equipped with this type of device.

# INTRODUCTION

## 6006H SERIES

Auto Crane products are designed to provide many years of safe, trouble-free, dependable service when properly used and maintained.

To assist you in obtaining the best service from your crane and to avoid untimely crane and/or vehicle failure, this manual provides the following operating and service instructions. It is **specifically recommended** that all operating and service personnel consider this manual as mandatory material for reading and study before operating or servicing Auto Crane products. It is **highly recommended** that crane owners, equipment managers and supervisors also read this manual.

Auto Crane has incorporated several safety features in the 6006H series cranes for your protection. The choice of materials and the design of the electrical system minimizes weight and lengthens durability. The hydraulic components meet or exceed a **3.5:1 safety factor**. Holding valves prevent the load from dropping if a hose should fail. A **10u filter** in the return line of the hydraulic system removes dirt and grit that may cause erratic operation. The reservoir has a **15u air filter** in the filler cap. The pump has a **40 mesh strainer** in the suction line.

For your convenience the overall dimensions of the 6006H series crane are on the General Dimension Drawing. Maximum turning radius at both the hoist motor and the rotation motor are also on that drawing.

Remember, the crane adds weight to the vehicle. Adding weight may change the driving and riding characteristics of the vehicle unless the appropriate overload spring(s) are installed on the truck. The payload of the vehicle is reduced by the weight of the crane. The operator should exercise care when loading the vehicle. Distributing the payload on the vehicle evenly will greatly improve the driving and riding characteristics of the vehicle. **A minimum G.V.W. of 14,500 lbs. is recommended for mounting the 6006H series cranes.**

---

**Auto Crane Company issues a limited warranty certificate with each unit sold. See last page for warranty policy.**

---

It has always been Auto Crane Company policy to handle all warranty claims we receive as promptly as possible. If a warranty claim involves discrepant material or workmanship, Auto Crane will take immediate corrective action. It is understandable that

Auto Crane Company cannot assume responsibility of liability when it is obvious that our products have been abused, mis-used, overloaded or otherwise damaged by inexperienced persons trying to operate the equipment without reading the manual.

**Auto Crane will not assume responsibility or liability for any modifications or changes made to unit, or installation of component parts done without authorization.**

Auto Crane maintains a strong distributor network and a knowledgeable Customer Service Department. In most cases, an equipment problem is solved via phone conversation with our customer service department. The customer service department also has the ability to bring a local distributor, a regional sales manager, or a factory serviceman into the solution of an equipment problem. If, through no fault of Auto Crane Company, it is necessary to send an experienced factory serviceman on a field service call, the rates stated in the Auto Crane Distributor's Flat Rate Manual will apply.

Auto Crane Company's extensive Research and Development Program allow our customers to use the best equipment on the market. Our Engineering Staff and our knowledgeable sales people, are always available to our customers in solving crane and winch-type application problems. When in doubt, call the Auto Crane factory.

### **DISTRIBUTOR ASSISTANCE:**

Should you require any assistance not given in this manual, we recommend that you consult your nearest Auto Crane Distributor. Our distributors sell authorized parts and have service departments that can solve almost any needed repair.

---

***NOTE: THIS MANUAL SHOULD REMAIN WITH THE CRANE AT ALL TIMES.***

---

This manual does not cover all maintenance, operating, or repair instructions pertinent to all possible situations. If you require additional information, please contact the **Auto Crane Company** at the following telephone number: **(918) 438-2760**. The information contained in the manual is in effect at the time of this printing. Auto Crane Company reserves the right to update this material without notice or obligation.



6006H SERIES - OWNER'S MANUAL  
**TABLE OF CONTENTS**



INTRODUCTION .....	1-1.0.0
OPERATING PRACTICES & <b>WARNINGS</b> .....	1-2.0.0
OPERATION OF UNIT / OUTRIGGERS .....	1-3.0.0
QUALIFICATIONS FOR OPERATORS .....	1-4.0.0
INSPECTION, TESTING & MAINTENANCE .....	1-5.0.0
MOUNTING AND INSTALLATION .....	2-1.0.0
CRANE ORIENTATION & HYDRAULIC HOOKUP .....	2-2.0.0
SAFETY DECAL SECTION .....	2-3.0.0
GENERAL DIMENSIONS .....	2-4.0.0
AMPLIFIER SETUP PROCEDURE .....	2-5.0.0
OPTIMETER TROUBLESHOOTING .....	2-7.0.0
HYDRAULIC VALVES, TROUBLESHOOTING .....	3-1.0.0
LIFE OF WIRE LINE .....	3-4.0.0
LUBRICATION & MAINTENANCE SCHEDULE .....	3-5.0.0
GENERAL ASSEMBLY (PEDESTAL) .....	4-1.0.0
BOOM ASSEMBLY .....	4-4.0.0
TWO-BLOCK ASSEMBLY .....	4-5.0.0
AUTOMATIC SAFETY BRAKE .....	4-7.0.0
ROTATION GEAR BOX .....	4-8.0.0
HOIST ACTUATOR .....	4-10.0.0
ELECTRICAL SECTION .....	5-2.0.0
HYDRAULIC SECTION .....	6-1.0.0
MISCELLANEOUS .....	8-1.0.0
LOAD CHART .....	9-9.9.9
WARRANTY .....	<b>LAST PAGE</b>

## ***--- IMPORTANT --- OPERATION OF UNIT***

1. Make sure this manual has been thoroughly read by all crane operating personnel and supervisors.
2. A routine inspection of the crane should be mandatory before each operating day. Any defects should be corrected immediately.
3. At a job site the vehicle should be positioned so that the crane can adequately reach the load within the rated capacity (centerline of rotation to hoist hook).
4. Keep the vehicle as level as possible during operation.
5. For electric cranes, **engage emergency brake** and leave ignition on with transmission in neutral (or in park for automatic transmissions). Activate any crane power switches. For Auto Crane units requiring battery and hydraulic operation, **engage emergency brake**, place gear selector in neutral, press clutch, activate PTO, release clutch and after hydraulic fluid is warm, set throttle control to proper engine speed.
6. Always use outriggers from the truck to the ground. Be sure these are firm and adequately positioned. When rotating, **keep load as low to the ground as possible**.
7. Remove pendant control from cab or storage area. On smaller units, plug pendant into receptacle on crane. On larger units, remove pendant control from guard and unwrap cable from boom. Do not operate crane until cable is unwound completely. On all cranes, detach hook from dead man. Crane is now ready for operation.
8. Always boom up before rotating so the boom will clear the required boom support.
9. When extending the boom, always maintain clearance between the boom crown and the traveling block or hoist hook.
10. Always observe safe and practical operation to avoid possible accidents. Refer to Safety Tips and Precautions.
11. After completing lifting operations, return the boom to stowed position on the boom support. Avoid unneeded pressure on the boom support.
12. Store pendant control on proper location (in cab or on crane).
13. Return outriggers to stowed position. Make sure they are pinned in place or jacklegs are returned to compartment.
14. Check work area for any tools or equipment not stored.
15. Release throttle control, depress clutch and disengage PTO. Deactivate any crane power switches.
16. Report any unusual occurrence during crane operation that may indicate required maintenance or repair.
17. **NEVER** use two cranes to support a load too large for either crane.
18. Spray all electrical equipment with special corrosion resistant coating. This eliminates rust or corrosion due to melting and freezing action of condensation.

## ***OPERATION OF OUTRIGGERS***

For hydraulic outriggers:

1. Shift crane/outrigger control valve to "outrigger" position.
2. While operating the outrigger control valves (located on the outrigger cylinders) simultaneously operate the boom-up control switch. This will allow the hydraulic system to build pressure.
3. After outriggers are positioned, return crane/outrigger selector to "crane" position.
4. Crane is now ready to operate.

For manual outriggers:

1. Pull lock pins to release jack leg or drop down outrigger and move to outermost lock position.
2. Make sure lock pins are reinstalled properly.
3. Lower outrigger pad to firm ground and adjust foot to take out slack.
4. Crane is now ready to operate.

# ***QUALIFICATIONS FOR AND CONDUCT OF OPERATORS AND OPERATING PRACTICES***

## **OPERATORS**

- 1 Crane operation shall be limited to personnel with the following minimum qualifications:**
  - A. designated persons
  - B. trainees under the direct supervision of a designated person
  - C. maintenance and test personnel (when it is necessary in the performance of their duties)
  - D. inspectors (crane).
- 2 No one other than the personnel specified above shall enter the operating area of a crane with the exception of persons such as oilers, supervisors, and those specified persons authorized by supervisors whose duties require them to do so and then only in the performance of their duties and with the knowledge of the operator or other persons.**

## **QUALIFICATIONS FOR OPERATORS**

- 3 Operators shall be required by the employer to pass a practical operating examination. Qualifications shall be limited to the specific type of equipment for which examined.**
- 4 Operators and operator trainees shall meet the following physical qualifications:**
  - A. Vision of at least 20/30 Snellen in one eye and 20/50 in the other, with or without corrective lenses.
  - B. Ability to distinguish colors, regardless of position, if colors differentiation is required for operation.
  - C. Adequate hearing with or without hearing aid for the specific operation.
- 5 Evidence of physical defects or emotional instability which render a hazard to operator or others, which in the opinion of the examiner could interfere with the operator's performance may be sufficient cause for disqualification. In such cases, specialized clinical or medical judgment and tests may be required.**
- 6 Evidence that the operator is subject to seizures or loss of physical control shall be sufficient reason for disqualification. Specialized medical tests may be required to determine these conditions.**

- 7 Operators and operator trainees should have normal depth perception, coordination, and no tendencies to dizziness or similar undesirable characteristics.**
- 8 In addition to the above listed requirements, the operator shall:**
  - A. Demonstrate the ability to comprehend and interpret all labels, operator's manuals, safety codes and other information pertinent to correct crane operations.
  - B. Possess knowledge of emergency procedures and implementation of same.
  - C. Demonstrate to the employer the ability to operate the specific type of equipment.
  - D. Be familiar with the applicable safety regulations.
  - E. Understand responsibility for maintenance requirements of crane.
  - F. Be thoroughly familiar with the crane and its control functions.
  - G. Understand the operating procedures as outlined by the manufacturer.

## **CONDUCT OF OPERATORS**

- 9 The operator shall not engage in any practice which will divert his attention while actually operating the crane.**
- 10 Each operator shall be responsible for those operations under the operator's direct control. Whenever there is any doubt as to safety, the operator shall consult with the supervisor before handling the loads.**
- 11 The operator should not leave a suspended load unattended unless specific precautions have been instituted and are in place.**
- 12 If there is a warning sign on the switch or engine starting controls, the operator shall not close the switch or start the engine until the warning sign has been removed by the appointed person.**
- 13 Before closing the switch or starting the engine, the operator shall see that all controls are in the "OFF" or neutral position and all personnel are in the clear.**
- 14 If power fails during operation, the operator shall:**
  - A. move power controls to the "OFF" or neutral position.

# ***QUALIFICATIONS FOR AND CONDUCT OF OPERATORS AND OPERATING PRACTICES***

B. land the suspended load and boom, if practical.

**15 The operator shall be familiar with the equipment and its proper care. If adjustments or repairs are necessary, the operator shall report the same promptly to the appointed person, and shall also notify the next operator.**

**16 All controls shall be tested by the operator at the start of each shift. If any controls do not operate properly, they shall be adjusted or repaired before operations are begun.**

**17 Stabilizers shall be visible to the operator while extending or setting unless operator is assisted by a signal person.**

## **OPERATING PRACTICES**

### **HANDLING THE LOAD**

#### **18 Size of load**

- A. No crane shall be loaded beyond the rated load except for test purposes.
- B. The load to be lifted is to be within the rated load of the crane and its existing configuration.
- C. When loads which are not accurately known are to be lifted, the person responsible for the job shall ascertain that the weight of the load does not exceed the crane rated load at the radius at which the load is to be lifted.

#### **19 Attaching the load**

- A. The load shall be attached to the hook by means of slings or other devices of sufficient capacity.
- B. Hoist rope shall not be wrapped around the load.

#### **20 Moving the load**

- A. The operator shall determine that:
- B. The crane is level and, where necessary, the vehicle/carrier is blocked properly.
- C. The load is well secured and balanced in the sling or lifting device before it is lifted more than a few inches.
- D. Means are provided to hold the vehicle stationary while operating the crane.
- E. Before starting to lift, the hook shall be brought over the load in such a manner as to minimize swinging.

F. During lifting care shall be taken that:

- 1. **there is no sudden acceleration or deceleration of the moving load.**
- 2. **load, boom or other parts of the crane do not contact any obstruction.**

G. Cranes shall not be used for dragging loads sideways.

H. This standard recognizes that articulating boom cranes are designed and intended for handling materials. They do not meet personnel lift or elevator requirements. Therefore, no lifting, lowering, swinging or traveling shall be done while a person is on the hook or load. Hook attached suspended work platforms (baskets) shall not be used with cranes covered by this standard. Work platforms attached to the boom must be approved by crane manufacturer.

I. The operator should avoid carrying loads over people.

J. When the crane is so equipped, the stabilizers shall be fully extended and set. Blocking under stabilizers shall meet the requirements as follows:

- 1. **strong enough to prevent crushing.**
- 2. **of such thickness, width and length as to completely support the stabilizer pad.**

K. Firm footing under all tires, or individual stabilizer pads should be level. Where such a footing is not otherwise supplied, it should be provided by timbers, cribbing, or other structural members to distribute the load so as to not exceed allowable bearing capacity or the underlying material.

L. In transit, the boom shall be carried in stowed position.

M. When rotating the crane, sudden starts and stops shall be avoided. rotational speed shall be such that the load does not swing out beyond the radius at which it can be controlled.

N. The crane shall not be transported with a load on the hook unless recommended by the manufacturer.

O. No person should be permitted to stand or pass under a suspended load.

**21 Stowing procedure. Follow the manufacturer's procedure and sequence when stowing and un-stowing the crane.**



# **QUALIFICATIONS FOR AND CONDUCT OF OPERATORS AND OPERATING PRACTICES**

## **MISCELLANEOUS**

### **OPERATING NEAR ELECTRICAL POWER LINES**

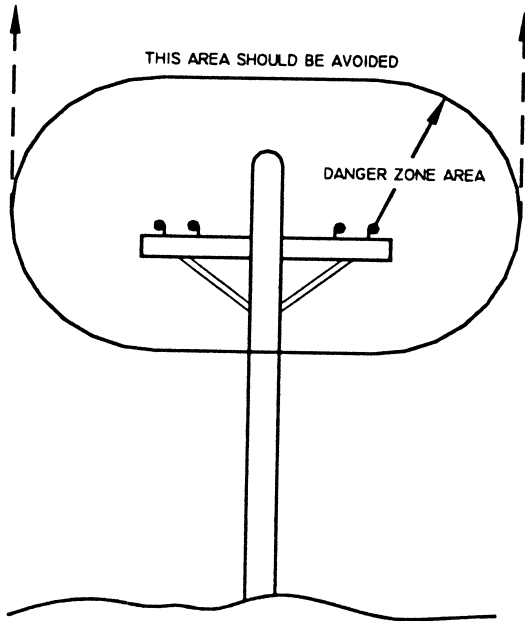

**22 Cranes shall be operated so that no part of the crane or load enters into the danger zone shown above.**

#### **EXCEPTIONS**

- A. The danger zone may be entered after confirmation by an appointed person that the electrical distribution and transmission lines have been de-energized and visibly grounded at the point of work; or
- B. The danger zone may be entered if insulating barriers (not a part of nor an attachment to the crane) have been erected to prevent physical contact with the lines.

**23 For lines rated 50 kV or below, minimum clearance between the lines and any part of the crane or load (including handling appendages) shall be 10 ft. (3m). For higher voltages, see Table 1.**

**24 Caution shall be exercised when working near overhead lines, because they can move horizontally or vertically due to wind, moving the danger zone to new positions.**

**25 In transit with no load and boom lowered the clearance shall be specified in Table 1.**

**26 A qualified signalperson shall be assigned to observe the clearance and give warning before approaching the above limits.**

- A. Any overhead wire shall be considered to be an energized line unless and until the person owning such line or the electrical utility authorities verify that it is not an energized line.
- B. Exceptions to this procedure, if approved by the administrative or regulatory authority if the alternate procedure provides equivalent protection and set forth in writing.
- C. Durable signs shall be installed at the operator's station and on the outside of the crane, warning that electrocution or serious bodily injury may occur unless a minimum clearance of 10 ft. (3.0m) between the crane or the load being handled and energized power lines. Greater clearances are required because of higher voltage as stated above. These signs shall be revised but not removed when local jurisdiction requires greater clearances.

**TABLE 1**

normal voltage, kV (phase to phase)		minimum required clearance	
		ft	(m)
<b><u>when operating near high voltage power lines</u></b>			
over	to 50	10	(3.05)
over	50 to 200	15	(4.6)
over	200 to 350	20	(6.1)
over	350 to 500	25	(7.62)
over	500 to 750	35	(10.67)
over	750 to 1000	45	(13.72)
<b><u>while in transit with no load and boom lowered</u></b>			
over	to 0.75	4	(1.22)
over	0.75 to 50	6	(1.83)
over	50 to 345	10	(3.83)
over	345 to 750	16	(4.87)
over	750 to 1000	20	(6.1)

# ***INSPECTION, TESTING AND MAINTENANCE***

## **GENERAL**

### **INSPECTION CLASSIFICATION**

**27 Initial inspection.** Prior to initial use, all new, altered, modified or extensively repaired cranes shall be inspected by a designated person to insure compliance with provisions of this standard.

**28 Regular inspection.** Inspection procedure for cranes in regular service is divided into two general classifications based upon the intervals at which inspection should be performed. The intervals in turn are dependent upon the nature of the components of the crane and the degree of their exposure to wear, deterioration, or malfunction. The two general classifications are herein designated as "frequent" and "periodic" with respective intervals between inspections as defined below.

- A. frequent inspection - daily to monthly intervals
- B. periodic inspection - one to twelve intervals, or as specifically recommended by the manufacturer

### **FREQUENT INSPECTION**

**29 Inspection shall be performed by designated personnel.**

- A. control mechanisms for maladjustment interfering with proper operation - daily, when used
- B. control mechanisms for excessive wear of components and contamination by lubricants or other foreign matter
- C. safety devices for malfunction
- D. all hydraulic hoses, particularly those which flex in normal operation of crane functions, should be visually inspected once every working day, when used
- E. hooks and latches for deformation, chemical damage, cracks, and wear. Refer to ANSI/ASME B30.10
- F. rope reeving for compliance with crane manufacturer's specifications, if optional winch is used

G. electrical apparatus for malfunctioning, signs of excessive deterioration, dirt and moisture accumulation

H. hydraulic system for proper oil level and leaks daily

I. tires for recommended inflation pressure, cuts and loose wheel nuts

J. connecting pins and locking device for wear and damage

### **PERIODIC INSPECTION**

**30 Deformed, cracked or corroded members in the crane structure and carrier.**

**31 Loose bolts, particularly mounting bolts.**

**32 Cracked or worn sheaves and drums.**

**33 Worn, cracked, or distorted parts such as pins, bearings, shafts, gears, rollers and devices.**

**34 Excessive wear on brake and clutch system parts and lining.**

**35 Crane hooks inspected for cracks.**

**36 Travel steering, braking, and locking devices, for malfunction.**

**37 Excessively worn or damaged tires.**

**38 Hydraulic and pneumatic hose, fittings, and tubing inspection.**

A. evidence of leakage at the surface of the flexible hose or its junction with metal and coupling

B. blistering, or abnormal deformation to the outer covering of the hydraulic or pneumatic hose

C. leakage at threaded or clamped joints that cannot be eliminated by normal tightening or recommended procedures

D. evidence or excessive abrasion or scrubbing on the outer surface of a hose, rigid tube, or fitting. Means shall be taken to eliminate the interference of

# ***INSPECTION, TESTING AND MAINTENANCE***

## **GENERAL**

elements in contact or otherwise protect the components

necessary to determine origin of the problem before corrective action can be taken.

### **39 Hydraulic and pneumatic pumps and motors inspection.**

- A. loose bolts or fasteners
- B. leaks at joints between sections
- C. shaft seal leaks
- D. unusual noises or vibrations
- E. loss of operating speed
- F. excessive heating of the fluid
- G. loss of pressure

### **40 Hydraulic and pneumatic valves inspection.**

- A. cracks in valve housing
- B. improper return of spool to neutral position
- C. leaks at spools or joints
- D. sticking spools
- E. failure of relief valves to attain or maintain correct pressure setting
- F. relief valve pressure shall be checked as specified by the manufacturers

### **41 Hydraulic and pneumatic cylinders inspection.**

- A. drifting caused by fluid leaking across piston
- B. rod seals leaking
- C. leaks at welding joints
- D. scored, nicked, or dented cylinder rods
- E. damaged case (barrel)
- F. loose or deformed rod eyes or connecting joints

**42 Hydraulic filters.** Evidence of rubber particles on the filter elements may indicate hose, "O" ring, or other rubber component deterioration. Metal chips or pieces on the filter may denote failure in pumps, motors, or cylinders. Further checking will be

**43 Labels are to be in place and legible.**

### **CRANES NOT IN REGULAR USE**

**44 A crane which has been idle for a period of over one month or more, but not less than six months, shall be given an inspection conforming with the initial-regular- frequent inspections.**

**45 A crane which has been idle for a period of over six months shall be given a complete inspection conforming with the initial-regular-frequent inspection requirements.**

### **INSPECTION RECORDS**

**46 Dated records for periodic inspection should be made on critical items such as brakes, crane hooks, rope, hydraulic and pneumatic cylinders, and hydraulic and pneumatic relief pressure valves. Records should be kept available to an appointed person.**

### **OPERATIONAL TESTS**

**47 Prior to initial use, all new, altered, modified, or extensively repaired cranes shall be tested for compliance with the operational requirements of this section, including functions such as the following:**

- A. load lifting and lowering mechanisms
- B. boom lifting and lowering mechanisms
- C. boom extension and retraction mechanisms
- D. swing mechanisms
- E. safety devices
- F. operating controls comply with appropriate function labels

***Operational crane test results shall be made available to an appointed person.***

### **RATED TEST LOAD**

***Prior to initial use, altered, modified, or extensively repaired cranes shall be load***

# ***INSPECTION, TESTING AND MAINTENANCE***

## **GENERAL**

***tested by or under the direction of an appointed person.***

**48 Test loads shall not exceed 110% of the manufacturer's load ratings.**

**49 Written reports shall be maintained showing test procedures and confirming the adequacy of repairs.**

## **MAINTENANCE**

### **PREVENTIVE MAINTENANCE**

**50 Before adjustment and repairs are started on a crane, the following precautions shall be taken as applicable:**

- A. crane placed where it will cause the least interference with other equipment or operations
- B. all controls at the "off" position
- C. starting means rendered inoperative
- D. boom lowered to the ground if possible or otherwise secured against dropping
- E. relieve hydraulic oil pressure from all hydraulic circuits before loosening or removing hydraulic components

**51 Warning or "OUT OF ORDER" signs shall be placed on the crane controls.**

**52 After adjustments and repairs have been made, the crane shall not be returned to service until all guards have been reinstalled, trapped air removed from hydraulic system (if required), safety devices reactivated, and maintenance equipment removed.**

### **ADJUSTMENTS AND REPAIRS**

**53 Any hazardous conditions disclosed by the inspection requirements shall be corrected before operation of crane is resumed, Adjustments and repairs shall be done only by designated personnel.**

**54 Adjustments shall be maintained to assure correct functioning of components, The following are examples:**

- A. functional operating mechanism
- B. safety devices
- C. control systems

**55 Repairs or replacements shall be provided as needed for operation.**

***The following are examples:***

- A. critical parts of functional operating mechanisms which are cracked, broken, corroded, bent, or excessively worn
- B. critical parts of the crane structure which are cracked, bent, broken, or excessively corroded
- C. crane hooks showing cracks, damage, or corrosion shall be taken out of service. Repairs by welding are not recommended

**56 Instructions shall be provided by the manufacturer for the removal of air from hydraulic circuits.**

## **LUBRICATION**

***All moving parts of the crane, for which lubrication is specified, should be regularly lubricated per the manufacturer's recommendations and procedures.***

## **ROPE INSPECTION**

**57 Frequent Inspection**

- A. All running ropes in service should be visually inspected once each working day. A visual inspection shall consist of observation of all rope which can be in use during the days operations. These visual observations should be considered with discovering gross damage such as listed below, which may be an immediate hazard.

- 1. distortion of the rope such as kinking, crushing, un-stranding, birdcaging, main strand displacement, or core protrusion. Loss of rope diameter in a short length or unevenness of outer strands should be replaced**

- 2. general corrosion**

# ***INSPECTION, TESTING AND MAINTENANCE***

## **GENERAL**

3. broken or cut strands;
4. number, distribution and type of visible broken wires. When such damage is discovered, the rope shall either be removed from service or given as inspection.

B. Care shall be taken when inspecting sections of rapid deterioration such as flange points, crossover points, and repetitive pickup points on drums.

### **58 Periodic inspection**

A. The inspection frequency shall be determined by a qualified person and shall be based on such factors as:

1. expected rope life as determined by experience on the particular installation or similar installations
2. severity of environment
3. percentage of capacity lifts
4. frequency rates of operation
5. exposure to shock loads

***Inspection need not be at equal calendar intervals and should be more frequent as the rope approaches the end of its service life. This inspection shall be made at least annually.***

B. Periodic inspection shall be performed by a designated person. This inspection shall cover the entire length of the rope. Only the surface wires need be inspected. No attempt should be made to open the rope. Any deterioration results in appreciable loss of original strength, such as described below, shall be noted and determination made as to whether use of the rope would constitute a hazard: points listed above reduction of rope diameter below nominal diameter due to loss of core support, internal or external corrosion, or wear of outside wires; severely corroded, cracked, bent, worn or improperly applied connections;

C. Care shall be taken when inspecting sections subject to rapid deterioration such as the following:

1. sections in contact with saddles, equalizer sheaves, or other sheaves where rope travel is limited
2. sections of the rope at or near terminal ends where corroded or broken wires may protrude

### **ROPE REPLACEMENT**

59 No precise rules can be given for determination of the exact time for replacement of rope, since many variable factors are involved.

***Continued use in this respect depends upon good judgement by a designated person in evaluating remaining strength in a used rope after allowance for deterioration disclosed by inspection. Continued rope operation depends upon this remaining strength.***

60 Conditions such as the following shall be reason for questioning continued use of the rope or increasing the frequency of inspection:

- A. in running ropes, six randomly distributed broken wires in one lay or three broken wires in one strand in one lay
- B. one outer wire broken at the contact point with the core of the rope structure and protrudes or loops out of the rope structure. Additional inspection of this section is required
- C. wear of one third of the original diameter of the outside individual wire
- D. kinking, crushing, birdcaging, or any other damage resulting in distortion of the rope structure
- E. evidence of any heat damage from any cause
- F. reduction from nominal diameter of more than 1/64 in. (0.4mm) for diameters up to and including 5/16 in. (8 mm), 1/32 in. (0.8 mm) for diameter 3/8 in. (9.5 mm) to and including 1/2 in. (13 mm), 3/64 in. (1.2 mm) for diameter 9/16 in. (14.5 mm) to and including 3/4 in. (19 mm). 1/16 in. (1.6 mm) for diameter 7/8 in. (22 mm) to and including 11/8 in. (29 mm), 3/32 in. (2.4 mm) for diameters 11/4 in. (32 mm) to and including 11/2 in. (38 mm)

# ***INSPECTION, TESTING AND MAINTENANCE***

## **GENERAL**

G. In standing ropes, more than two broken wires in one lay in sections beyond end connections or more than one broken wire at an end connection.

H. Replacement rope shall have a strength rating at least as great as the original rope furnished or recommended by the crane manufacturer. Any deviation from the original size, grade, or construction shall be specified by a rope manufacturer, or a qualified person.

**61 Rope not in regular use:** all rope which has been idle for a period of a month or more due to shutdown or storage of a crane on which it is installed, shall be given an inspection in accordance with above information before it is placed in service. This inspection shall be for all types of deterioration and shall be performed by a qualified person.

### **62 Inspection records**

- A. frequent inspection- no records required
- B. periodic inspections- in order to establish data as a basis for judging the proper time for replacement, a dated report condition at each periodic inspection should be kept on file. This report shall cover points of deterioration listed above.

### **ROPE MAINTENANCE**

**63 Rope should be stored to prevent damage or deterioration.**

**64 Unreeling or uncoiling of rope shall be done as recommended by the rope manufacturer and with care to avoid kinking or inducing twist.**

**65 Before cutting a rope, seizing shall be placed on each side of the place where the rope is to be cut to prevent unlaying of the strands. On pre-formed rope, one seizing on each side of the cut is required. On non-preformed ropes of 7/8 in. (22 mm) diameter or smaller, two seizings on each side of the cut are required, and for non-preformed rope 1 in. (25 mm) diameter or larger, three seizings on each side of the cut are required.**

**66 During installation care should be exercised to avoid dragging of the rope in the dirt or around objects which will scrape, nick crush or induce sharp bends in it.**

**67 Rope should be maintained in a well-lubricated condition. It is important that lubricant applied as a part of a maintenance program shall be compatible with the original lubricant and to this end the rope manufacturer should be consulted. Lubricant applied shall be the type which does not hinder visual inspection. Those sections of rope which are located over sheaves or otherwise hidden during inspection and maintenance procedures require special attention when lubricating rope. The object of rope lubrication is to reduce internal friction and to prevent corrosion.**

**68 When an operating rope shows greater wear or well defined localized areas than on the remainder of the rope, rope life can be extended in cases where a section at the worn end, and thus shifting the wear to different areas of the rope.**

# ***MOUNTING and INSTALLATION 6006H***

1. Check to make sure the following items are with your crane:

ITEM	PART NO.	DESCRIPTION
1.	366203000	Swivel Block
2.	366212000	Vented Relief Valve (Non-proportional Units Only)
3.	480525000	Control Valve Assembly (Proportional Units Only)
4.	480018000	Pump Assembly (Optional)
5.	999946000	Owners Manual
6.	015104000	Bolt system: 7/8 NF x 5", Grade 8, (4 Req'd)

2. Pressure and return hoses are not furnished with this crane. The hoses must be provided by the installer and the lengths determined at installation.

## **REQUIREMENTS FOR INSTALLATION USING 8 GALLON RESERVOIR WITH RELIEF VALVE AND AUTO CRANE PROVIDED PUMP**

A. RETURN LINE FROM CRANE TO RESERVOIR (IN COMPARTMENT): -8 SAE 100R2 (OR EQUIVALENT). HOSE LENGTH IS DETERMINED BY INSTALLER. RETURN LINES LONGER THAN 6 FEET SHOULD BE SIZE -12. HOSE END FITTINGS ARE -8 JIC FEMALE SWIVEL (CRANE END) AND -10 JIC FEMALE SWIVEL (RESERVOIR END).

B. PRESSURE LINE FROM VENTED RELIEF VALVE TO CRANE: -8 SAE 100R2 (OR EQUIVALENT). HOSE LENGTH IS DETERMINED BY INSTALLER. HOSE END FITTINGS ARE BOTH -8 JIC FEMALE SWIVEL.

**NOTE: CRANE MUST USE RELIEF VALVE P/N 366212, WHICH IS PROVIDED.**

C. SUCTION HOSE FROM PUMP TO RESERVOIR: -16 HYDRAULIC SUCTION HOSE WITH TWO (2) -16 HOSE CLAMPS ON EACH END.

D. PRESSURE LINE FROM PUMP TO VENTED RELIEF VALVE (LOCATED ON RESERVOIR) : -12 SAE 100R2 (OR EQUIVALENT). HOSE LENGTH IS DETERMINED BY INSTALLER. HOSE END FITTINGS ARE BOTH -10 JIC FEMALE SWIVEL.

### **NOTE:**

REFER TO OWNERS MANUAL FOR ADDITIONAL INSTALLATION INFORMATION, AND OTHER RESERVOIR AND PUMP COMBINATIONS.

## **CAUTION - FAILURE TO USE CLEAN HYDRAULIC HOSES AND COMPONENTS MAY CONTAMINATE THE CRANE AND HYDRAULIC SYSTEM AND VOID WARRANTY.**

- Crane must be provided with a flow of 8 gallons per minute and a pressure of 2200 PSI. Excess flow will cause erratic operation, and too little flow will cause poor crane operation.
- Vehicle should meet minimum GVW rating of 14,500 pounds.
- The vehicle **MUST** be equipped with an engine speed control and tachometer.
- Make sure mounting surface is properly reinforced to withstand 36,000 ft-lb capacity loading of crane and that outriggers are used to provide total stability for the truck.
- A 13 1/2" dia. hole should be cut out of mounting location (centered with mounting bolts) for access to lower ring gear bolts and hydraulic connections.
- Make sure the mounting bolts are 7/8x dia, grade 8. Torque bolts to 440 ft-lbs (dry).
- When crane is not in operation, a boom support should always be used. Traveling block should be connected to hood loop.
- Always use cable loops on side of boom and pendant guard on side of pedesal to store pendant assembly, if this type of storage applies.

# ***MOUNTING and INSTALLATION 6006H***

11. **CHECK FOR PROPER PRESSURE AND RETURN LINE HOOK-UP TO CRANE:**  
***PRESSURE PORT IS ON RIGHT SIDE AS VIEWED FROM THE REAR OF THE CRANE.***
12. Use medium pressure Auto Crane filter in the return line unless filter exit port is mounted directly to the reservoir.
13. Electrical hookup:
  - NON-REMOVABLE PENDANT UNITS:**
    - A. RUN THE FOLLOWING WIRES THROUGH HOLE IN BASE ASSEMBLY OF CRANE AND SEAL WITH SILICONE RUBBER TO PREVENT WIRE CHAFING AND LEAKS.
    - B. CONNECT WIRE FROM DIRECTIONAL VALVE SOLENOID (P/N 480137) TO WHITE WIRE W/ TRACER AT PENDANT CABLE END.
    - C. CONNECT POWER CONDUCTOR FROM STARTER SOLENOID TO BLACK WIRE AT BASE OF CRANE, PASSING THROUGH THE MAIN POWER RELAY. USE THE IN-LINE FUSE PROVIDED.
  - removable pendant units:
    - A. OBTAIN THE PROPER WIRING DIAGRAM.
    - B. WIRE TERMINAL STRIP PER DIAGRAM AND PROTECT STRIP FROM ACCIDENTAL CONTACT.

**WARNING! FAILURE TO CORRECTLY PLUMB AND WIRE CRANE CAN CAUSE INADVERTENT OPERATION AND DAMAGE TO CRANE AND/OR PERSONNEL!**

14. Once crane and plumbing are installed on the truck, fill the reservoir to top of sight glass (mobil DTE 13 or equal). Before operating crane, connect together the pressure and return hoses going to base of crane using -8 JIC union and engage PTO with engine running. Allow oil to circulate for 15 to 20 minutes. This will flush contaminants from the system back to the return line filter. Operate all cylinders to full extension and retraction a minimum of six times, to bleed air from system. Return all cylinders to the stored position and disengage PTO. Refill reservoir to top sight glass. To ensure 8 gallons per minute (GPM), install an in-line flow meter between the crane and the reservoir in the return hose, or confirm pump speed pump speed is correct. The proper speed for Auto Crane gear pump P/N 480018 is 1000 RPM.
15. Proper pressure setting can be achieved by, with the PTO disengaged, removing the pipe plug on the pipe plug on the vented relief valve or proportional valve and installing a 2500 PSI pressure gauge. Extend the boom "in" all the way and continue holding the switch on. For proportional systems, the trigger should be pulled completely back (on). Read the pressure gauge and adjust relief valve to read 2200 PSI. Recheck pressure setting to verify adjustment.
16. Load test the crane to ensure proper functioning and truck stability.
17. Make certain the owner's manual is delivered to the customer.
18. For additional help: call the service department at the Auto Crane Company. (918) 836-0463 (TULSA, OKLAHOMA)



# ***MOUNTING and INSTALLATION 6006H***

## **WARNING**

**FEDERAL LAW** (49 CFR PART 571) REQUIRES THAT THE FINAL STAGE MANUFACTURER OF A VEHICLE CERTIFY THAT THE VEHICLE COMPLIES WITH ALL APPLICABLE FEDERAL REGULATIONS. ANY MODIFICATIONS PERFORMED ON THE VEHICLE PRIOR TO THE FINAL STAGE ARE ALSO CONSIDERED INTERMEDIATE STAGE MANUFACTURING AND MUST BE CERTIFIED AS TO COMPLIANCE. THE INSTALLER OF THIS CRANE AND BODY IS CONSIDERED ONE OF THE MANUFACTURERS OF THE VEHICLE. AS SUCH A MANUFACTURER, THE INSTALLER IS RESPONSIBLE FOR COMPLIANCE WITH ALL APPLICABLE FEDERAL AND STATE REGULATIONS, AND IS REQUIRED TO CERTIFY THAT THE VEHICLE IS IN COMPLIANCE.

**IT IS THE FURTHER RESPONSIBILITY** OF THE INSTALLER OF THE CRANE TO COMPLY WITH THE **OSHA** TRUCK CRANE STABILITY REQUIREMENTS AS SPECIFIED BY 29 CFR PART 1910.180 (C) (1).

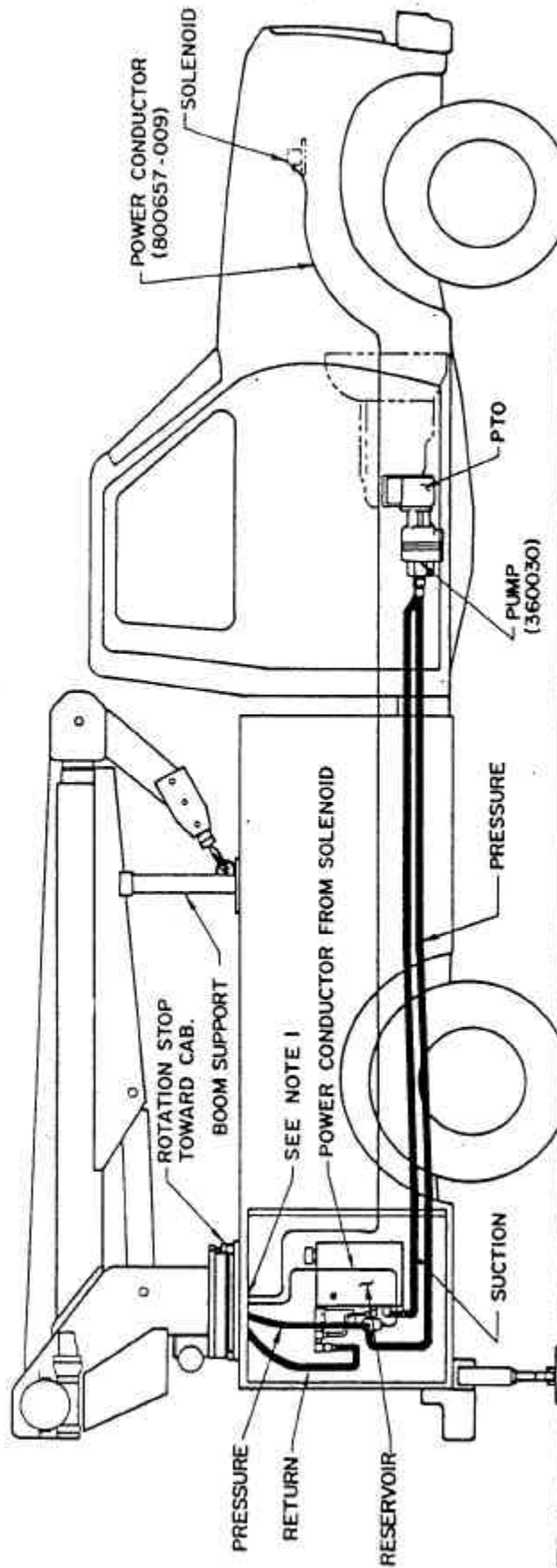

**NOTES**

1. AFTER POWER CONDUCTORS ARE INSERTED THROUGH HOLE IN BASE OF CRANE, SEAL ALL AROUND WITH SILICONE RUBBER, OR EQUAL, TO PREVENT WIRE DAMAGE.

**MOUNTING AND INSTALLATION, 6006H**

**AW - 072**

FIXTURE NO.	FINISH NO.	CHG LTR	REVISIONS	DESCRIPTION	DATE	APP'D
-------------	------------	---------	-----------	-------------	------	-------

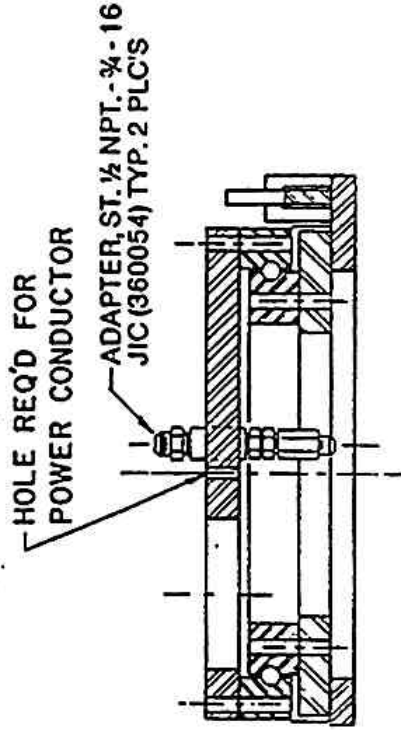

SECTION A-A

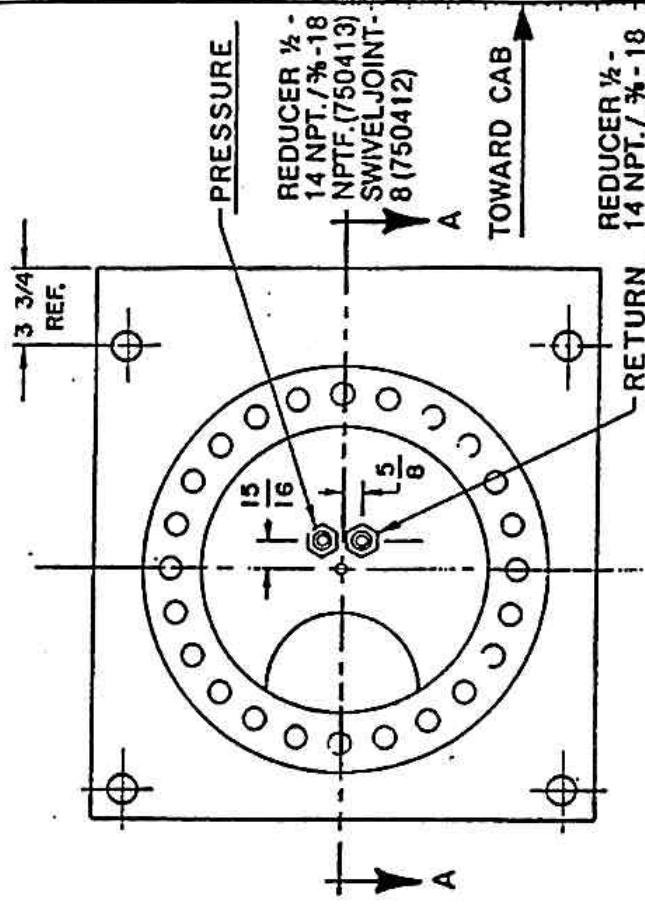

BOTTOM VIEW

ITEM	D/S	PART NO.	DESCRIPTION
LIST OF MATERIAL			
<b>AUTO CRANE COMPANY</b>			
<b>BASE ASSEMBLY</b>			
QUANTITY		TITLE	
UNLESS OTHERWISE NOTED ALL DIMENSIONS ARE IN INCHES. TOLERANCES UNLESS OTHERWISE SPECIFIED.		DRAWN BY R.P.	
ANGLES ± 1/2° .XX ± .40 FRACTIONAL ± 1/16 .XXX ± .010 REMOVE ALL BURRS AND SHARP EDGES. DO NOT SCALE THIS DRAWING.		DATE 7/10/86	
TOLERANCES NOT SHOWN ABOVE ARE PER ANSI Y14.5-1973		CHK'D BY	
THIS PRINT IS THE PROPERTY OF AUTO CRANE CO. AND MUST NOT BE USED IN ANY MANNER DETRIMENTAL TO THEIR INTERESTS.		DATE	
NEXT ASS'Y		SCALE	REVISION
12/86		B	ENG - 61
		SIZE	SHEET 1 OF 1

## AUTO CRANE'S SUGGESTED BOOM SUPPORT

LEAVE 3/4" CLEARANCE ON EACH SIDE OF BOOM

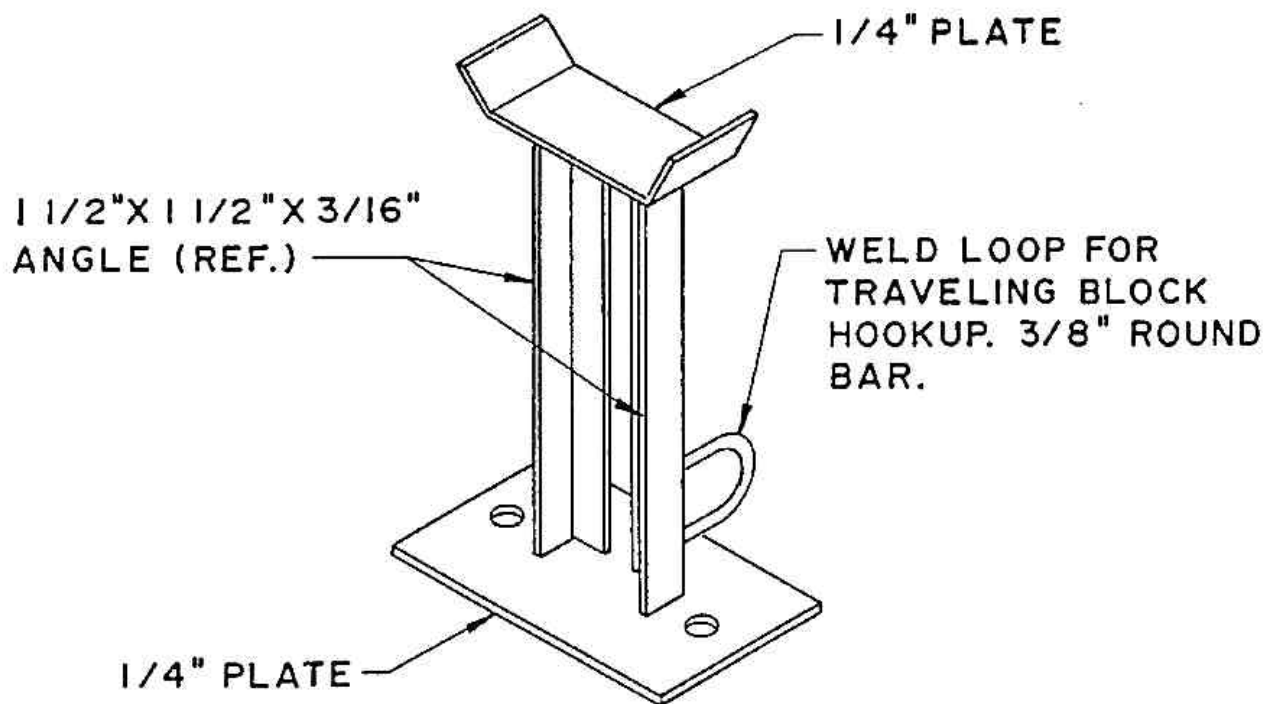

BOOM SUPPORT IS REQUIRED.

**AUTO CRANE COMPANY**

P.O. BOX 580697 TULSA OKLAHOMA 74158-0697  
4707 N. MINGO ROAD 918-836-0463

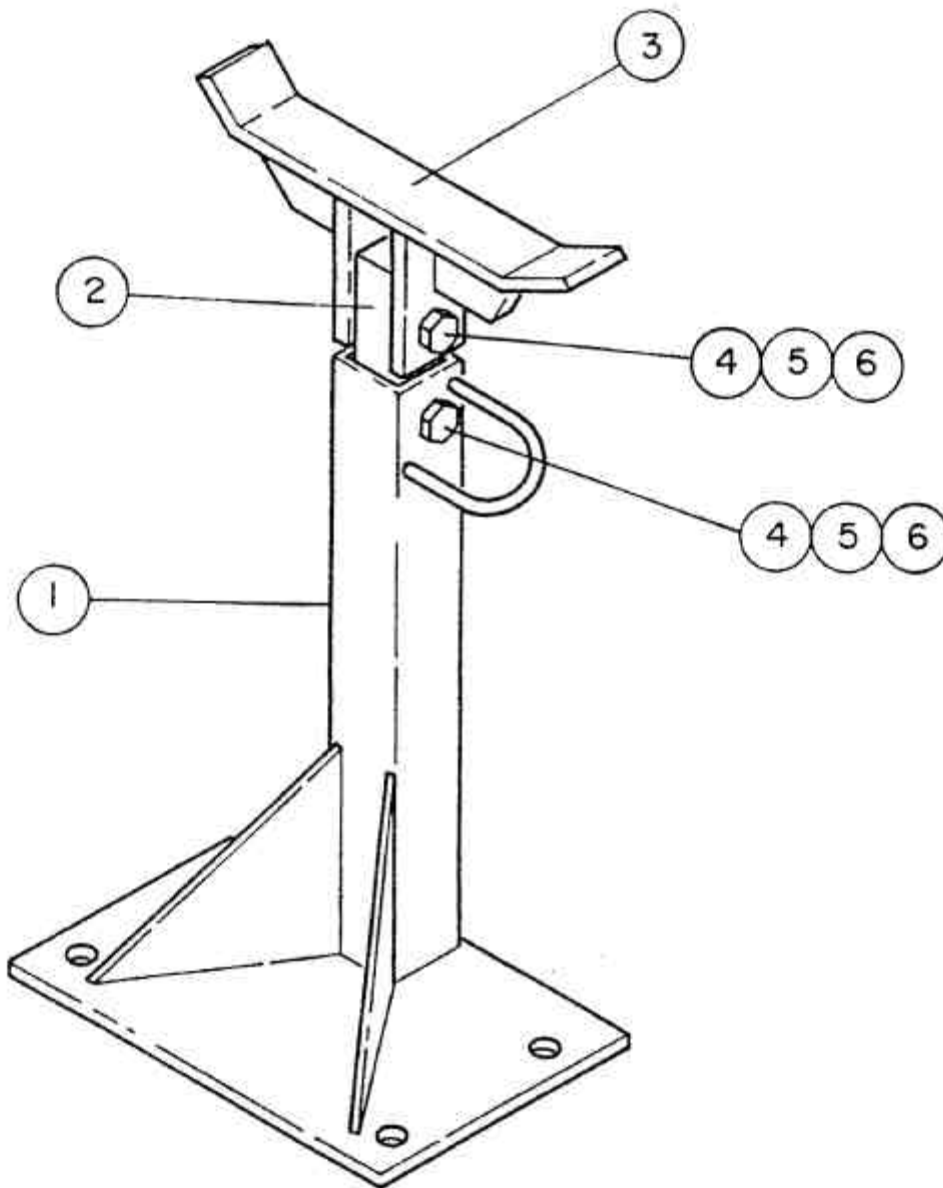

<u>ITEM</u>	<u>QTY</u>	<u>PART NO.</u>	<u>DESCRIPTION</u>
1	1	750586	BASE
2	1	750590	EXTENSION TUBE
3	1	750589	BOOM SUPPORT
4	2	009800	BOLT, HX. 3/8" NF
5	2	017102	NUT HX. 3/8" NF
6	2	021101	WASHER, SP. LK. 3/8"

AW-081 BOOM SUPPORT (P/N 750585)

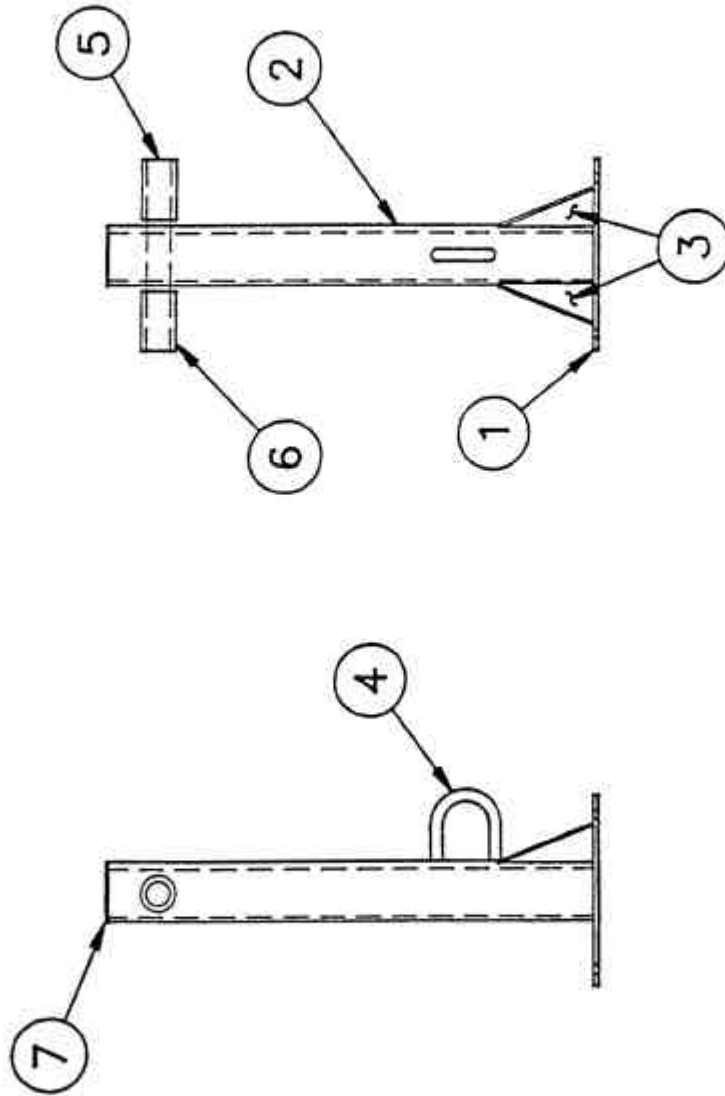
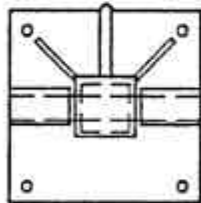

7	1	800224-003	BAR, RT. HR. 1/8 x 2 1/2 x 2 1/2 x 2 1/2" LG.
6	2	360275-004	HOSE, -16 x 2 1/2" LG.
5	1	800356-007	BAR, RD. CD. 1 x 8" LG.
4	1	230400	HOOK, HOIST CABLE
3	2	725224	GUSSET
2	1	725226	UPRIGHT, 5005H & 6006H
1	1	725223	BASE

**AUTO CRANE COMPANY**  
 P.O. BOX 500697 TULSA, OKLAHOMA 74158-0697  
 4707 NORTH HINGED ROAD 918-836-0463

TITLE

**SUPPORT, BOOM  
 (5005H & 6006H)**

SCALE 1/8" = 1'-0"  
 SHEET NO. A  
 DRAWING NO. 725222  
 REVISION

# SAFETY DECAL SECTION

## 6006H

Revised 8/97

PART NO.: 040579  
DECAL: OPERATION INSTRUCTIONS  
FUNCTION: To inform the operator of the proper procedure to follow for safe operation of the crane.  
USED ON: All cranes  
QUANTITY: 1  
PLACEMENT: Right side plate  
:

FIG.

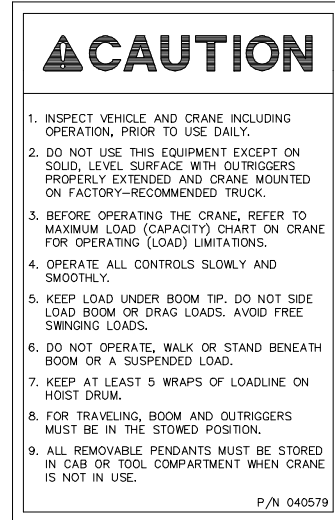

PART NO.: 040580  
DECAL: OPERATOR TRAINING  
FUNCTION: To inform the operator of the need to receive proper training before using the crane.  
USED ON: All cranes  
QUANTITY: 1  
PLACEMENT: Right side plate

FIG. SD-2

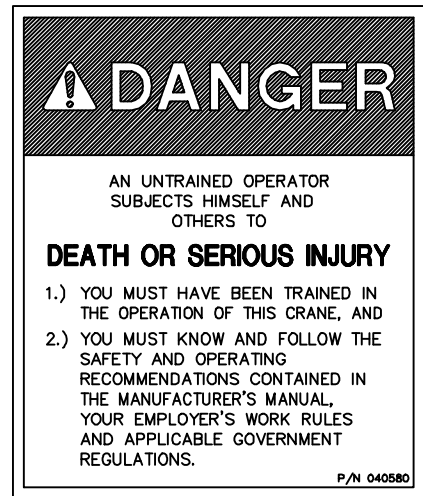

PART NO.: 040632  
DECAL: TAMPERING WITH OVERLOAD DEVICE  
FUNCTION: To inform the operator that tampering with the overload device may cause a unit failure or possible personnel injury.  
USED ON: All cranes equipped with a load sensor.  
QUANTITY: 1  
PLACEMENT: Right side of valve cover

FIG. SD-3

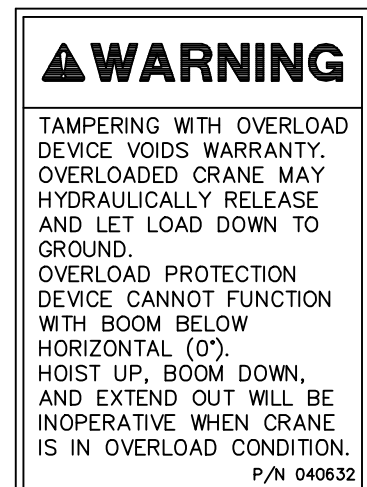

# SAFETY DECAL SECTION

## 6006H

Revised 8/97

PART NO.: 040529  
 DECAL: ELECTROCUTION HAZARD  
 FUNCTION: To inform the operator of the hazard involved with contacting electrical power lines with crane boom.  
 USED ON: Articulated & Stiff Boom Cranes  
 QUANTITY: 2  
 PLACEMENT: Both sides of end of lower boom

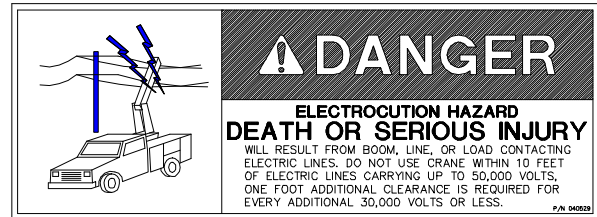

FIG. SD-4

PART NO.: 040517  
 DECAL: STAY CLEAR OF BOOM  
 FUNCTION: To inform the operator of the hazard of proximity or contact with the crane boom during operation.  
 USED ON: All cranes  
 QUANTITY: 2  
 PLACEMENT: Both sides of crown

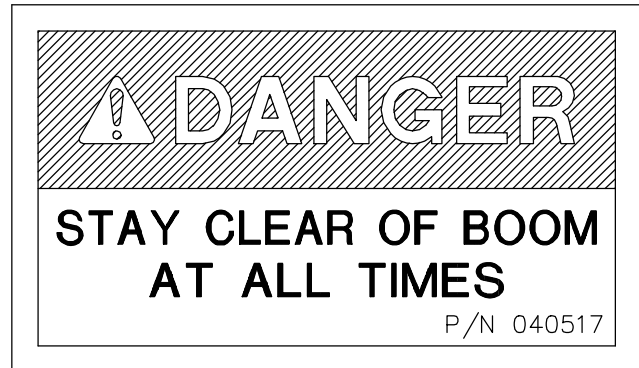

FIG. SD-5

PART NO.: 040518  
 DECAL: STAY CLEAR OF LOAD  
 FUNCTION: To inform the operator of the hazard of proximity or contact with the crane load during operation.  
 USED ON: All cranes  
 QUANTITY: 2  
 PLACEMENT: Both sides of crown plate

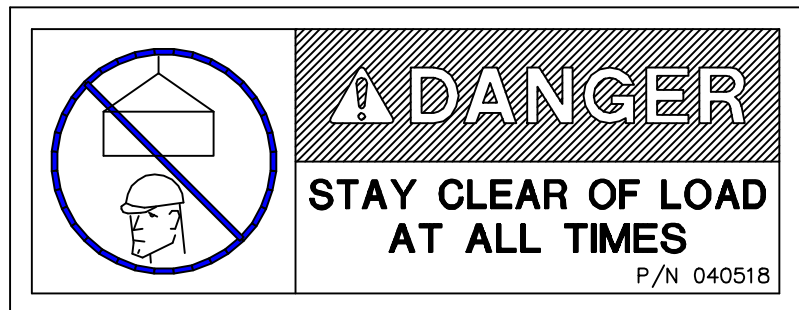

FIG. SD-6



# SAFETY DECAL SECTION

## 6006H

Revised 8/97

PART NO.: 040587  
 DECAL: LOAD SENSOR, DON'T TAMPER  
 FUNCTION: To inform the operator that the load sensor is pre-set and that tampering with the sensor may cause potentially hazardous situation.  
 USED ON: All cranes equipped with a load sensor.  
 QUANTITY: 1  
 PLACEMENT: On the lift cylinder near the load sensor

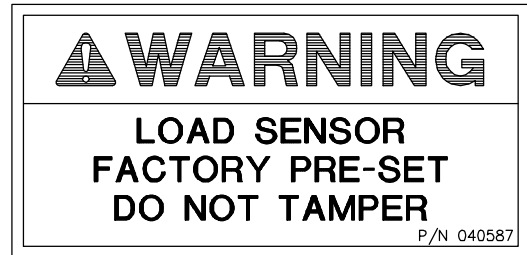

FIG. SD-7

PART NO.: 040519	USED ON: All cranes
DECAL: SCISSORS POINT	QUANTITY: 2
FUNCTION: To inform the operator of possible danger at scissors point on crane.	PLACEMENT: Both sides of the lift cylinder

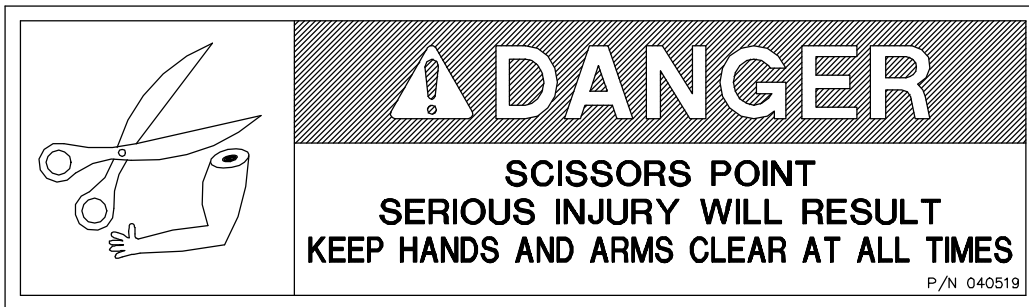

FIG. SD-8

PART NO.: 366209  
 DECAL: HYDRAULIC REQUIREMENTS  
 FUNCTION: To inform the operator of the hydraulic requirements for proper crane operation  
 USED ON: 6006h  
 QUANTITY: 1  
 PLACEMENT: On the hydraulic reservoir.

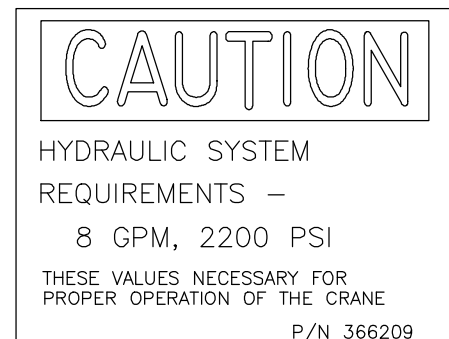
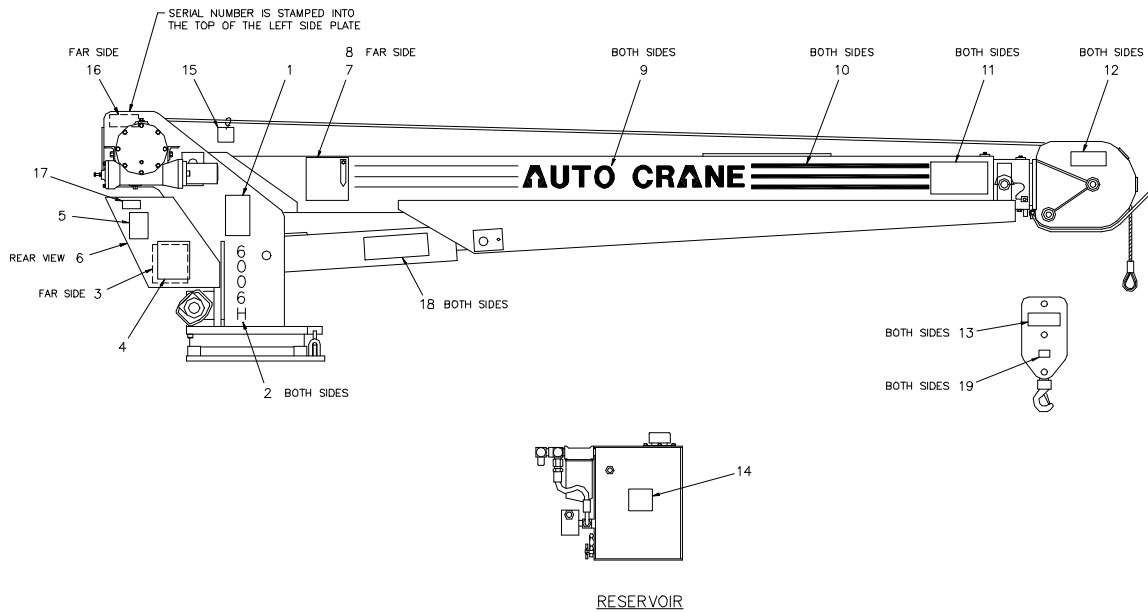

FIG. SD-9

# DECAL LAYOUT

## 6006H



ITEM	QTY	PART NO.	DESCRIPTION	ITEM	QTY	PART NO.	DESCRIPTION
1	1	040579	DECAL, CAUTION—WORK RULES	11	2	040529	DECAL, DANGER—SHOCK
2	2	366210	DECAL, 6006H	12	2	040517	DECAL, DANGER—STAY CLEAR
3	1	366195	DECAL, LOAD CHART	13	2	040518	DECAL, DANGER—STAY CLEAR
4	1	040580	DECAL, DANGER—OPERATE	14	1	366209	CAUTION — 8 GPM
5	1	040632	DECAL, DANGER—CYL. OPERATION	15	1	999946	INSTALLATION CHECKLIST
6	1	360034	DECAL, LOGO	16	1	330622	DECAL, SERIAL NO.
7	1	360036	DECAL, ANGLE INDICATOR, RIGHT	17	1	330633	DECAL, OPTI—FLOW
8	1	360037	DECAL, ANGLE INDICATOR, LEFT	18	2	040519	DECAL, DANGER—SCISSOR POINT
9	2	040624	DECAL, AUTO CRANE	19	2	366203—100	DECAL, BLOCK WEIGHT & MAX. LOAD
10	13'	040620	STRIPING				

# GENERAL DIMENSIONS

## 6006H

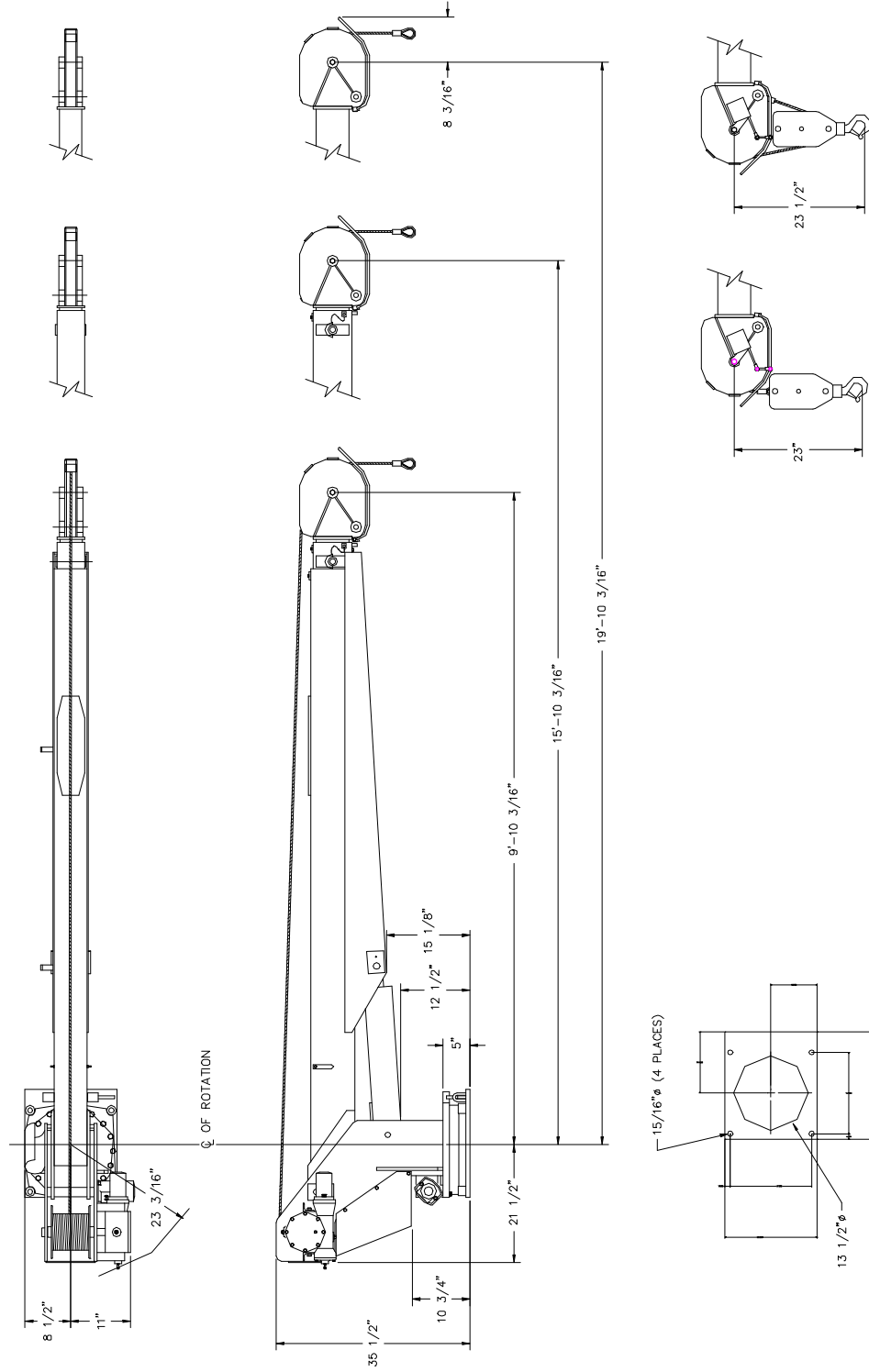

AW-071  
6006H GENERAL DIMENSIONS

# ***INSTALLATION & SETUP PROCEDURE DIGITAL PULSE WIDTH AMPLIFIER***

## **INSTALLATION:**

1. Install amplifier at a convenient location near the proportional crane terminal strip (see Proportional Crane Wiring Diagrams) using two screws and lock nuts provided.
2. At the 12-station terminal block, disconnect all power to the system.
3. Connect the DIN connector plug to the proportional valve, making sure the gasket seals properly. Secure the plug to the proportional valve coil with screw. Attach wires per applicable wiring diagram.

### **ATTACH WIRES IN THIS ORDER: (numbers are on 22-station terminal strip)**

1. Attach the **BLACK** wire to terminal “N” (#13).
2. Attach the **RED** wire to terminal “T” (#10).
3. Attach the **WHITE** wire too terminal “M” (#12).
4. Attach the **GREEN** wire to the **BROWN** wire from the proportional DIN connector plug using the bullet connector supplied.

**Caution: Failure to do so may cause premature amplifier failure and void warranty.**

**Observe all connections for proper installation before connecting power to the terminal block. Proceed to the setup procedure.**

## **SETUP:**

1. Remove four screws on the front plate of amplifier and remove front plate.
2. With power on, pull pendant trigger to full on position. Adjust potentiometer adjustment screw located next to the red light (see Figure 1) until light just turns off, then turn trim pot back until the light just comes on. The light should stay on during the full trigger movement. Clockwise rotation to the trim pot will turn light off. Counterclockwise rotation will turn the light on. This “tunes” the amplifier to the trigger potentiometer.
3. After warming the hydraulic system oil, determine which function should be used to set the low position switch (ROTATE uses the least amount of pressure). Activate that function with trigger released, and turn the lower range setting dial (See Figure 1, marked with “L” on circuit board) until the desired speed is reached. The “Zero” and the “F” on the dial are opposite ends of the switch. To adjust the low set point, **turn CLOCKWISE direction for INCREASED FLOW; turn COUNTERCLOCKWISE direction for DECREASED FLOW.** This adjusts the “Threshold Speed” for the trigger in the released position.
4. Operate the boom up function with trigger pulled back to the maximum position. Turn the high range setting dial (See Figure 1, marked with “H” on circuit board) until there is a noticeable decrease in speed, then back up one or two notches as desired.

## ***INSTALLATION & SETUP PROCEDURE DIGITAL PULSE WIDTH AMPLIFIER***

“Zero” is the maximum speed setting and “F” is the most reduced speed setting. To set the high range dial, turn **CLOCKWISE** direction for **DECREASED FLOW**; turn **COUNTERCLOCKWISE** direction for **INCREASED FLOW**. This operation adjusts the trigger “Dead Band” at the fully pulled position.

5. Replace cover and install screws. Make sure the amplifier wiring is secured and does not interfere with rotating hoses and electrical wiring.

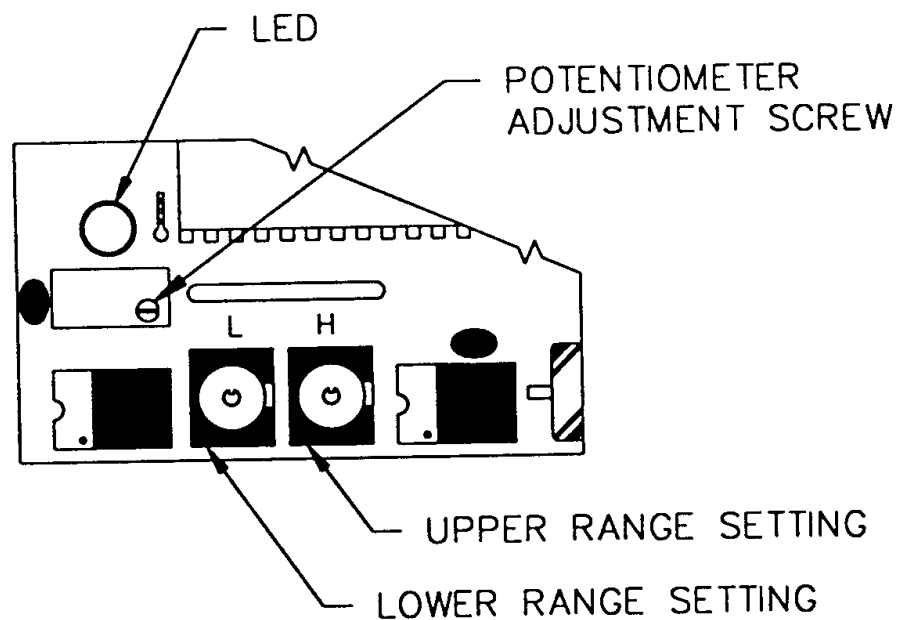

**Figure 1**

# **OVERLOAD SYSTEM / ANTI-2-BLOCK**

## **TROUBLE SHOOTING GUIDE**

### **IF THE THREE FUNCTIONS, BOOM DOWN, HOIST UP AND EXTEND OUT, QUIT WORKING,**

the problem probably lies in either the Overload System or the Anti-2-block system or both. If these three functions are NOT WORKING and most other functions are, an investigation should be made as follows: (reference: Figure 1)

#### **1 ANTI-2-BLOCK**

- A. Unplug the anti-2-block system from the overload system and connect A and B to bypass the anti-2-block system.
- 1. If the three functions work, check continuity of anti-2-block system using continuity tester at disconnected. Weather pack connectors, and investigate switch at end of boom, cable and cable reel.**
  - 2. If the three functions do not work, continue on with section #2.**

#### **2 LOAD SENSOR (Pressure Switch)**

- A. With crane unloaded, unplug weather pack connector on load sensor wire.
- 1. If the three functions work, recheck the Pressure Switch by taking a ohm reading on the two wires coming from the Switch. The switch has normally open contacts, so the reading should be the maximum. If less than maximum ohm reading is indicated (usually a dead short), replace the Switch.**
  - 2. If the three functions do not work, continue with section #3.**

#### **3 RELAY BOX**

- A. Inside this box are two 320355 relays. Since these are inexpensive relays, the easiest way to trouble shoot this device is to replace both relays.
- 1. The two relays are identical but serve different functions. RELAY A is the one with the most wires going to its connector. RELAY A breaks the circuit between the ground side of the solenoid valves on boom down, extend out, and hoist up functions. This happens whenever the overload switch on the lift cylinder senses more than normal pressure indicating an overload condition. When overload happens then 12 volts is passed through the overload switch to pull in RELAY A which then interrupts the ground circuit of the valves controlling those**

**functions which could cause additional overload. In addition to this, when there is also a signal from the boom down solenoid to RELAY B at the same time, RELAY B latches RELAY A so that even if the overload signal from the pressure switch to RELAY A is removed, RELAY A will continue to be on and interrupt the ground circuit until the signal from the boom down solenoid and pressure switch are removed.**

- 2. The purpose of RELAY A is to interrupt the ground circuit and stop hoist up, boom down, and extend out functions from operating. The purpose of RELAY B is to stop boom bounce caused by the overload system cycling on and off.**

#### **4 OPERATIONAL TEST AND TROUBLE SHOOTING OF RELAY BOX**

- A. After the anti-2-block test and the load sensor tests have been performed and the overload system still does not operate, check the relay box.
- 1. Disconnect the weatherpak connector in the load sensor pressure switch wires going from the pressure switch to the relay box. Disconnect the weatherpak connector between the cord reel and the relay box.**
  - 2. Check for 12 volts at pin B of load sensor connector on relay box side of harness. Short from pin A to pin B of weatherpak. When pins A & B are shorted there should NOT be continuity from the cord reel weatherpak on the relay box side of the connection to ground. When A & B are not shorted there should be continuity to ground. Replace relay A if these conditions are not met.**
  - 3. If the boom tends to bounce when booming down due to intermittent cycling of the overload system, then RELAY B should be replaced after verifying that the sense wire from the relay box to the boom down solenoid valve control terminal is connected.**

# OVERLOAD SYSTEM / ANTI-2-BLOCK

## TROUBLE SHOOTING GUIDE

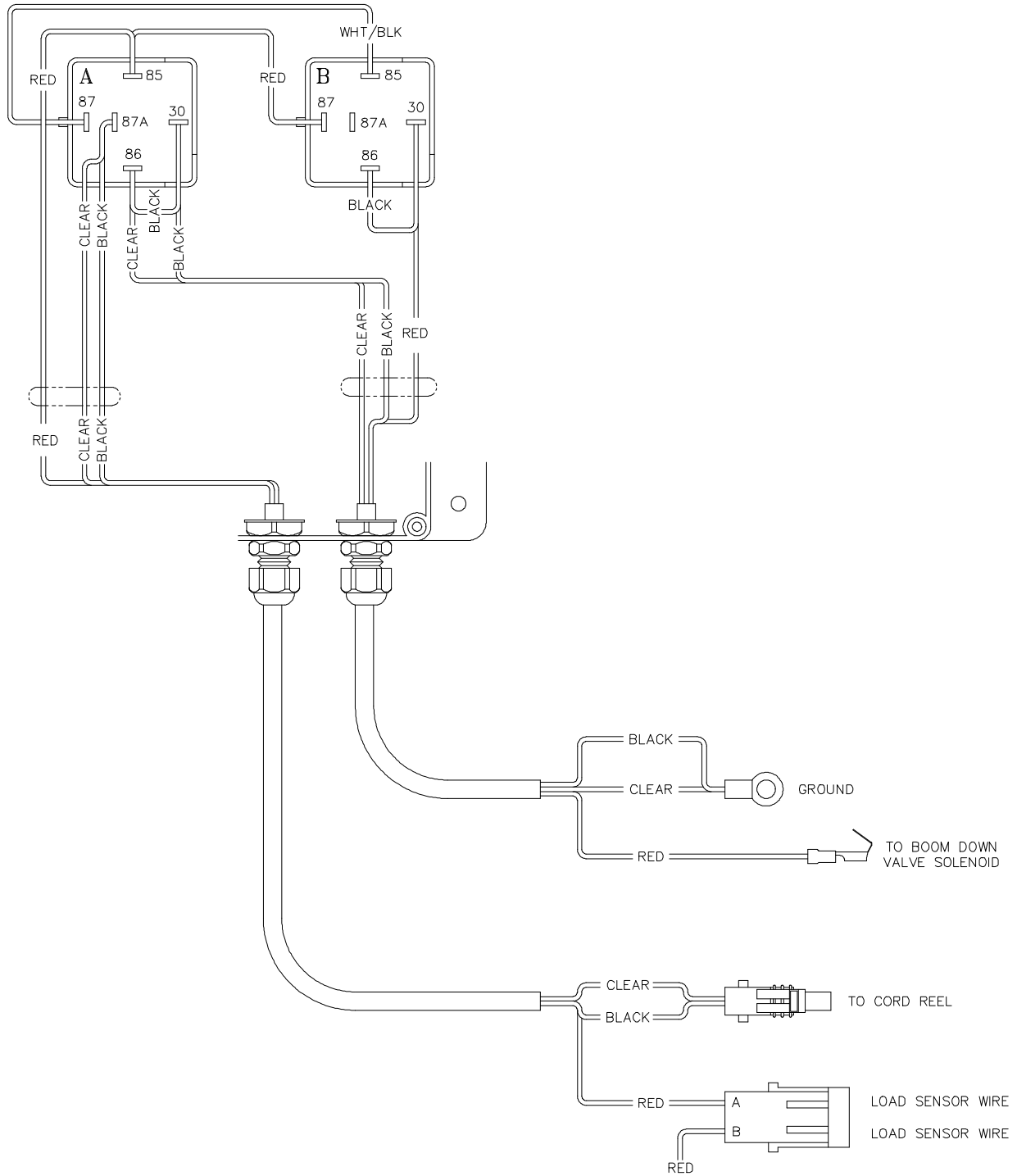

# RELAY BOX ASSEMBLY

## P/N 366999 - 6006H MARINE

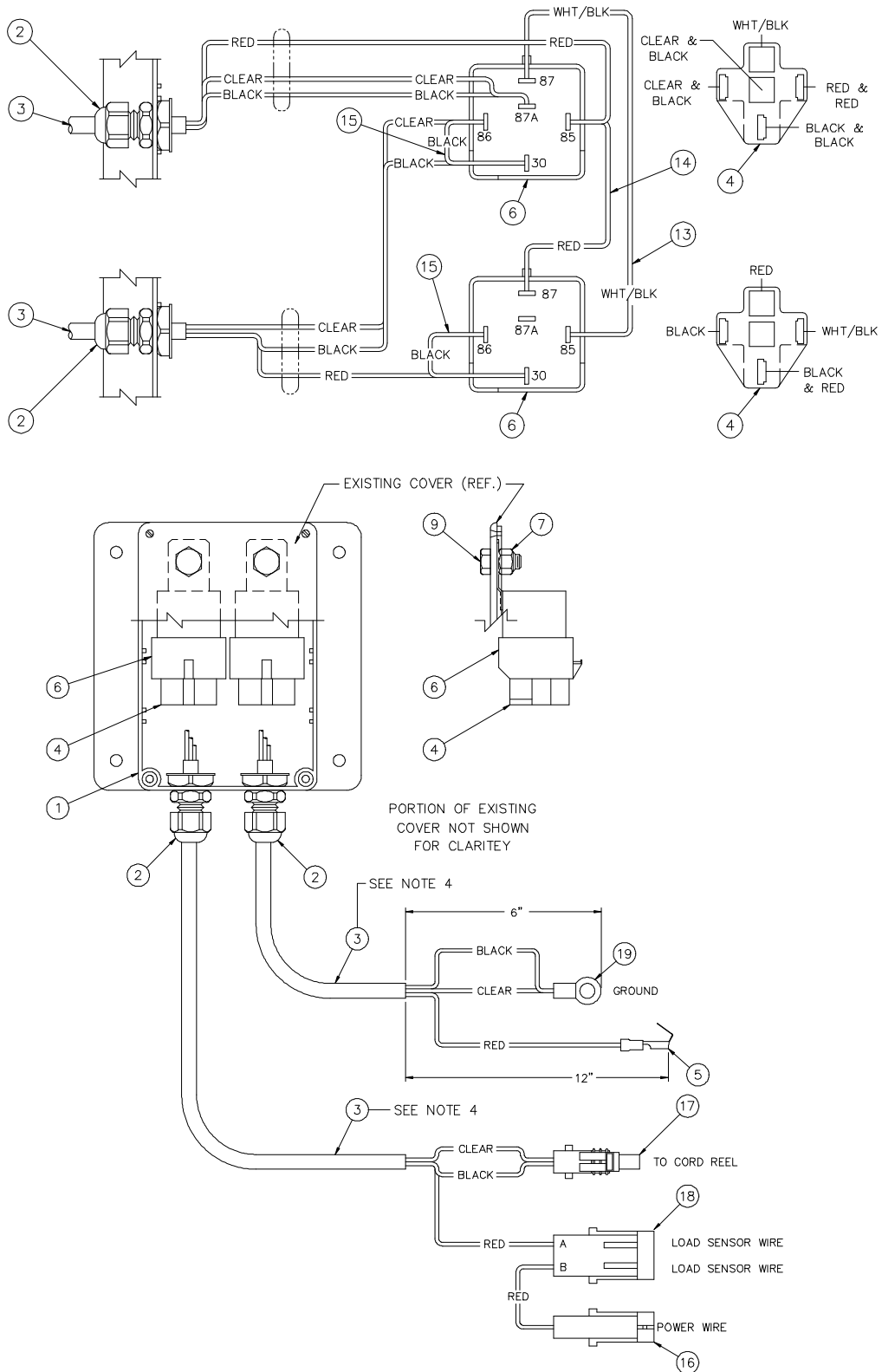



# ***RELAY BOX ASSEMBLY***

## ***P/N 366999 - 6006H MARINE***

<b><u>ITEM</u></b>	<b><u>QTY</u></b>	<b><u>P/N</u></b>	<b><u>DESCRIPTION</u></b>
1	1	366990	PLASTIC ENCLOSURE W/ 6 DRILL HOLES
2	12	366968	CORD CONNECTOR
3	2	366967	SHIELDED CABLE 3-CONDUCTOR 18-20
4	2	320363	TERMINAL CONNECTOR PLUG
5	1	366980	PIGGY BACK TERMINAL INSULATED 18-20
6	2	320355	BOSCH DROP OUT RELAY
7	2	005901	HEX HD SCREW 1/4-20 NC x 1/2 LG
8	-	-	-
9	2	016300	LOCK NUT 1/4-20 NC
10	-	-	-
11	-	-	-
12	11	320357	NON-INSULATED TERMINAL W/ LOCK DEVICE
13	1	341566	WHT/BLK ELECTRICAL WIRE 18 AWG 600V
14	1	341564	RED ELECTRICAL WIRE 18 AWG 600V
15	1	341565	BLACK ELECTRICAL WIRE 18 AWG 600V
16	1	366248	WEATHER PACK 1-WAY MALE 18-20
17	1	366249	WEATHER PACK 1-WAY FEMALE 18-20
18	1	366250	WEATHER PACK 1-WAY MALE 18-20
19	1	000601	RING TERMINAL 10-3/8
20	3	750737	CABLE TIE

# ***OPTIMETER TROUBLE SHOOTING***

## ***GUIDE for 11006***

### **Follow the troubleshooting sequence.**

1. Obtain the proper wiring diagram and check wiring.
  2. With truck running, check terminal "L" voltage
    - A. If 12 - 13.75 volts, proceed.
    - B. If not, check for blown fuse or broken wires.
  3. Install pendant, turn system power on (8-switch pendants only), and check terminal "t" for truck voltage.
    - A. If truck voltage, proceed.
    - B. If no voltage or low voltage (less than truck voltage), make sure the power switch on the 8-switch pendant is in the "on" position. (Does not apply to 4-switch pendant.)
    - C. Then, check for loose connection in the pendant or a broken wire in the pendant cable.
  4. Disconnect bullet connector on line connecting connecting green wire from amplifier to brown wire from proportional valve DIN connector. Then ground brown wire to a chassis ground. This will send maximum current thru proportional valve and should close it completely.
- OR**
5. Depress the manual operator pin on top of the valve with an allen wrench till valve closes completely.
  6. Check for proper crane operation.
    - A. If crane operates properly, proceed.
    - B. If not, check coil resistance from pin to pin (should be 5.0 ohms) and from pin to ground ring on coil (should be infinite resistance). If resistance is much different than above, replace coil, then proceed.
    - C. Re-connect brown and green wire.
  7. Check terminal "m" for 0.5 volts with trigger released.
    - A. Solid truck voltage at terminal "m" means a loss of ground. Search the ground wire for bad connections or breaks and repair.
    - B. If more than 0.7 volts or less than 0.2 volts with trigger released, readjust trigger on pot shaft. (Note: care must be taken when handling the pot assembly to keep from breaking the wires at their attachment points.)
    - C. If voltage is correct with trigger released, smoothly activate trigger looking for a smooth gradual increase of voltage near 5.0 volts at maximum pulled position (3.5 to 7 volts is OK).
    - D. If voltage is erratic and jumps up to truck voltage and back down during the trigger movement, replace potentiometer assembly.
  8. Pull trigger and check for red light inside amplifier then perform the following adjustments with the trigger pulled to the maximum position:
    - A. Light off  
Turn small trim pot screw counterclockwise (left) till light just gets bright, then stop. (If 10 turns do not turn light on, look for more than 9 volts at terminal "m".)
    - B. Light on  
Turn small trim pot screw clockwise (right) till light just turns off, then turn counterclockwise (left) till light just gets bright, then stop. (If 10 turns do not turn light off, look for less than 1 volt at terminal "m".)
  9. Release trigger.

# ***OPTIMETER TROUBLE SHOOTING***

## ***GUIDE for 11006***

- 10.** Set the two adjustment switches (hi and lo) to number "4". (One side of the switch knob has an indicator.)
- 11.** the *LO* switch takes the "dead space" out of the beginning trigger activation, and will continue to raise the low signal to give half flow with the trigger at full released position. The higher the number or letter (0 thru f), the higher the flow to the crane with the trigger in the fully released position.
- 12.** The *HI* switch takes the "dead space" out of the full trigger position, and will continue to lower the high signal to half the flow at the maximum trigger pulled position. The higher the number or letter (0 thru f), the lower the flow to the crane with the trigger in the fully pulled position.
- 13.** A good starting position would be to have both switches on the number "4".
- 14.** NOTE: Both switches on "F" will limit flow to a median value and not allow any change.

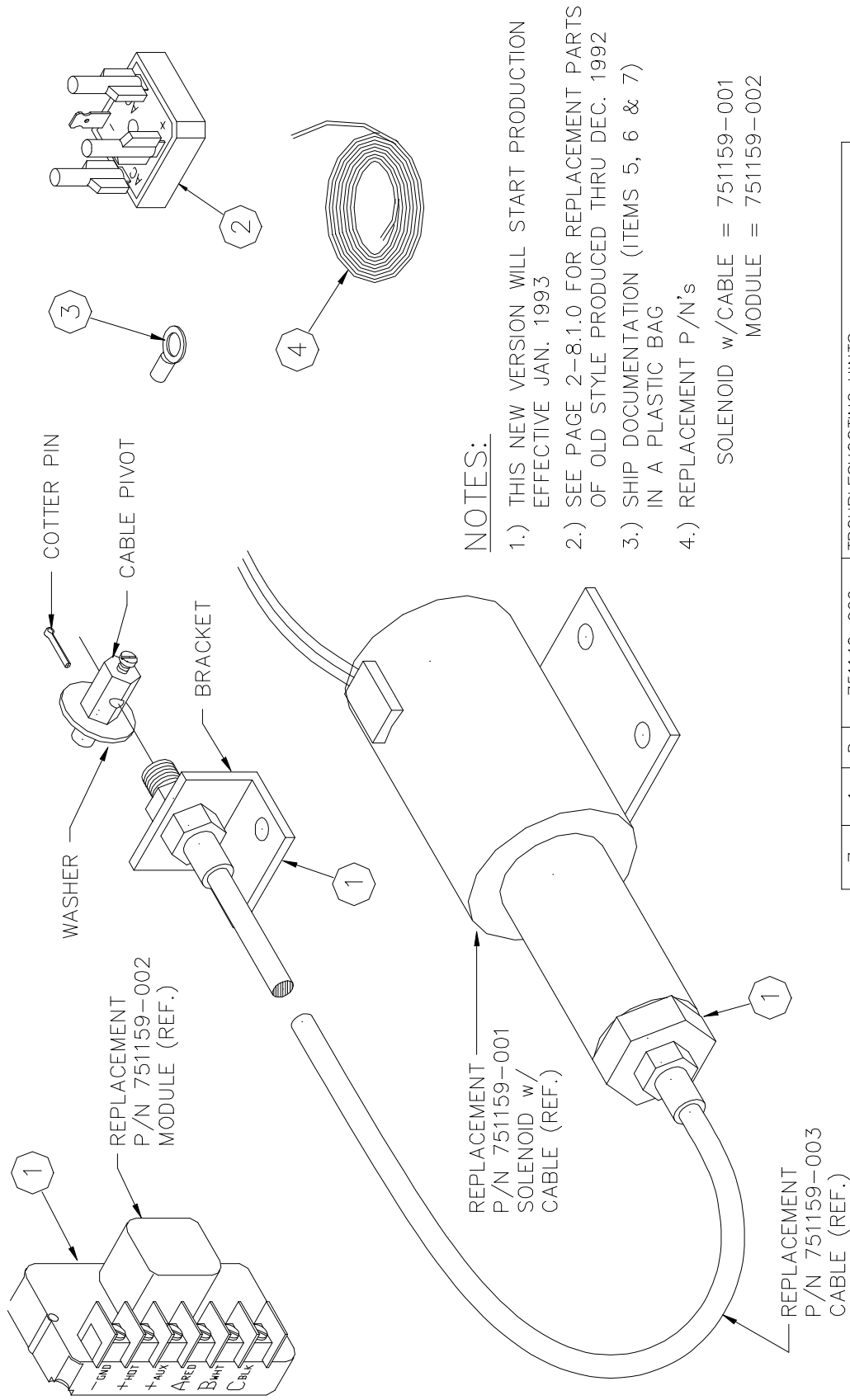

**NOTES:**

- 1.) THIS NEW VERSION WILL START PRODUCTION EFFECTIVE JAN. 1993
- 2.) SEE PAGE 2-8.1.0 FOR REPLACEMENT PARTS OF OLD STYLE PRODUCED THRU DEC. 1992
- 3.) SHIP DOCUMENTATION (ITEMS 5, 6 & 7) IN A PLASTIC BAG
- 4.) REPLACEMENT P/N's

SOLENOID w/CABLE = 751159-001  
 MODULE = 751159-002

ITEM	QTY	D/S	PART No.	DESCRIPTION
7	1	D	751140-999	TROUBLESHOOTING HINTS
6	1	D	751140-999	INSTALLATION INSTRUCTIONS (2 PAGES)
5	1	D	751140-999	WIRING DIAGRAM (AW751140)
4	15'	A	800603-009	WIRE, 16 Ga. WHT w/ BLK TRACER x 15' LG
3	8	A	000101	TERMINAL, RING #6
2	1	A	751143-001	ISOLATOR MODULE ASSEMBLY
1	1	B	751159	12 VDC SOLENOID w/ CONTROL MODULE

**AW-180  
 THROTTLE SOLENOID ASSY**

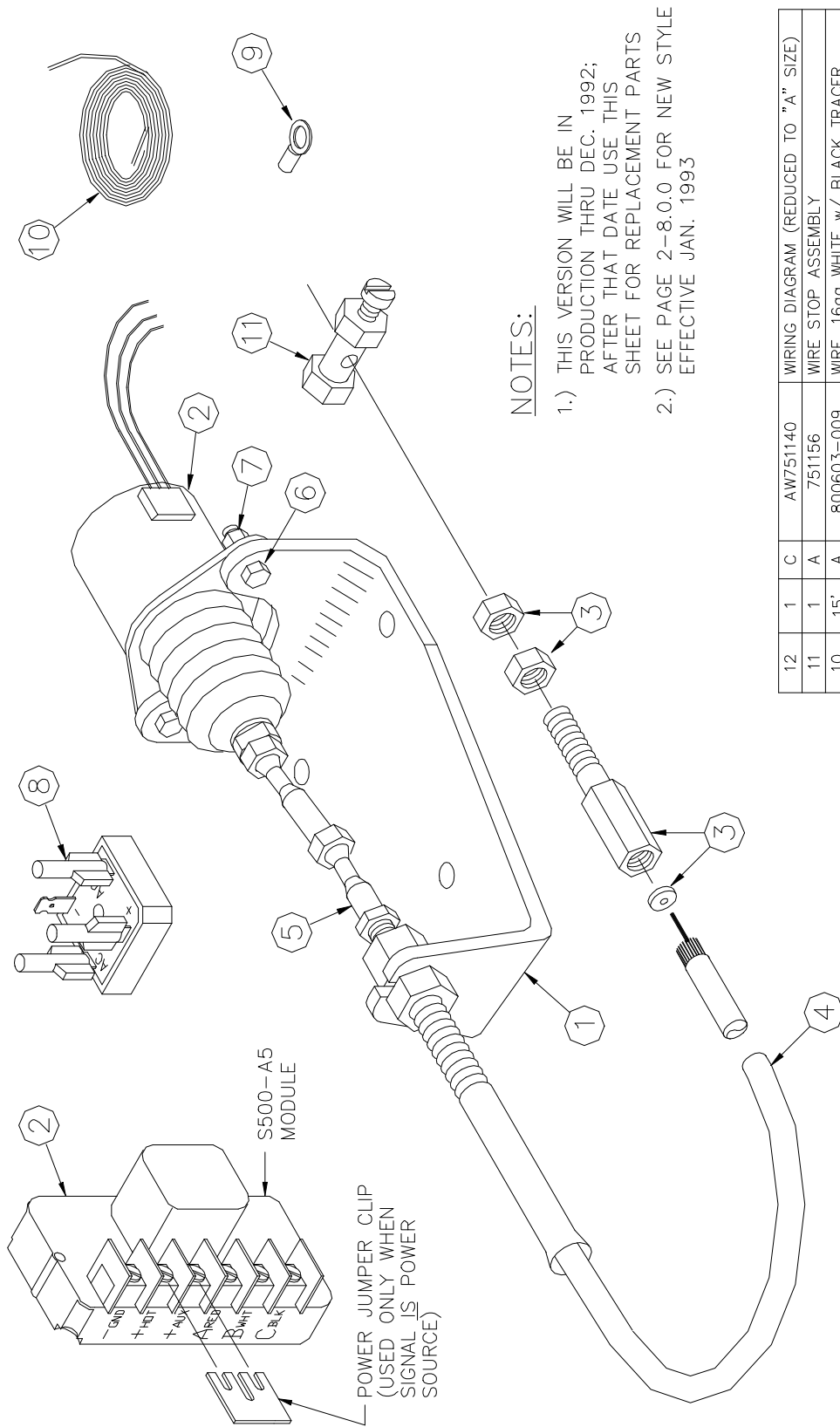

**NOTES:**

- 1.) THIS VERSION WILL BE IN PRODUCTION THRU DEC. 1992; AFTER THAT DATE USE THIS SHEET FOR REPLACEMENT PARTS
- 2.) SEE PAGE 2-8.0.0 FOR NEW STYLE EFFECTIVE JAN. 1993

ITEM	QTY	D/S	PART No.	DESCRIPTION
12	1	C	AW751140	WIRING DIAGRAM (REDUCED TO "A" SIZE)
11	1	A	751156	WIRE STOP ASSEMBLY
10	15'	A	800603-009	WIRE, 16ga WHITE w/ BLACK TRACER
9	8	A	000101	TERMINAL WIRE #6
8	1	A	751143-001	ISOLATOR MODULE ASSY
7	2	A	016300	NUT, HX-LOCK 1/4-20NC
6	2	A	005500	SCREW, HX HD 1/4-20NC x 3/4 LG
5	2	A	751137	BALL JOINT, STRAIGHT
4	1	A	751148	THROTTLE CABLE
3	1	A	751149	BULKHEAD FITTING
2	1	B	751141	12 VDC SOLENOID w/ CONTROL MODULE
1	1	C	751146	BRACKET, THROTTLE SOLENOID

AW-180  
THROTTLE SOLENOID ASSY

# THROTTLE CONTROL SOLENOID INSTALLATION

## LOCATION

Follow these simple rules to properly locate your throttle control kit:

- 1 Mount the solenoid off the engine but within 46 inches of the throttle lever, to avoid engine vibration and high temperature components (more than 257 °F [125 °C]).
- 2 Mount control module out of the engine compartment if possible. If not possible, mount the module as far away from high temperature components as possible. Maximum temperature range is 185 °F (85 °C).
- 3 Route the flexible cable away from high temperature (220° F [105° C]) components such as exhaust manifolds.
- 4 Avoid sharp bends in flexible cable. Bends should form a smooth arc (360° maximum) with a radius of 5 inches minimum.

## CONTROLLING THE SOLENOID THROTTLE KIT

The throttle kit can be controlled remotely by applying a low current 12 VDC signal to the module "AUX" terminal.

Examples of activating signals are an air compressor pressure switch or a crane "dump valve" coil.

## MOUNTING PROCEDURES

Use the following procedure to mount your throttle controller:

- 1 Mount the solenoid and control module according to the recommendations in the "LOCATION" instructions.
- 2 Electrically connect the solenoid to the control module and power source according to the wiring diagram.
- 3 Mount the cable bracket and fasten the cable sheath to the bracket using the collar nut so the sheath does not turn during idle adjustment.

## SET HIGH ENGINE IDLE SPEED NOTE:

Do not leave the aluminum adjustment nut tight against the solenoid body since this does not allow the cable to float.

- 1 Make sure the jam nut is loose and turn the aluminum adjustment nut clockwise until the high engine idle speed is reached.
- 2 Tighten the jam nut.
- 3 Check the throttle speed controller operation by rechecking the "normal" engine idle speed with the solenoid de-activated and the high engine idle speed with the solenoid activated.

## SYSTEM OPERATION

The control module allows the solenoid to operate as a continuous duty device. When the module is wired as recommended, applying 12 VDC to the "AUX" terminal applies voltage to the hold-in and pull-in coil of the solenoid. After 0.5 to 0.75 seconds, power is automatically removed from the pull-in coil. Power will remain at the hold-in coil

# THROTTLE CONTROL SOLENOID INSTALLATION

until the 12 VDC signal is removed from the "AUX" terminal.

**WARNING !!** To avoid control module damage, always disconnect the module when you jump-start the vehicle with voltages that exceed 32 VDC.

## TROUBLESHOOTING HINTS

If solenoid will not engage, check the following:

- 1 Check the stranded pull cable for damage (e.g., melted or crimped sheath)
- 2 Check the stranded pull cable for binding.
- 3 Check system voltage at the "+HOT" and "+AUX" terminals.
- 4 Check module terminals for proper voltage and operation. If the module does not meet the specifications shown below, replace it.

GND	Chassis Ground
+HOT	12 VDC at all times
+AUX	12 VDC required to activate solenoid
A RED	12 VDC when signal is present at "AUX" terminal
B WHT	12 VDC for 0.5 to 0.75 seconds after signal at "AUX" terminal is present
C BLK	Common for solenoid

## CONTROL MODULE VOLTAGE MEASUREMENTS

- 5 Check solenoid resistance (remove wires from module). If resistance is not within specifications listed below, replace the

A. White to Black wire - 0.17 ohms

B. Red to Black wire - 13 ohms

solenoid.

- 6 Make sure you have used the recommended wire length and gage (refer to the chart on AW751140)
- 7 Be sure cable is not bent beyond guidelines.
- 8 Check for proper adjustments.
- 9 Contact Auto Crane Company if you are unable to resolve the problem.

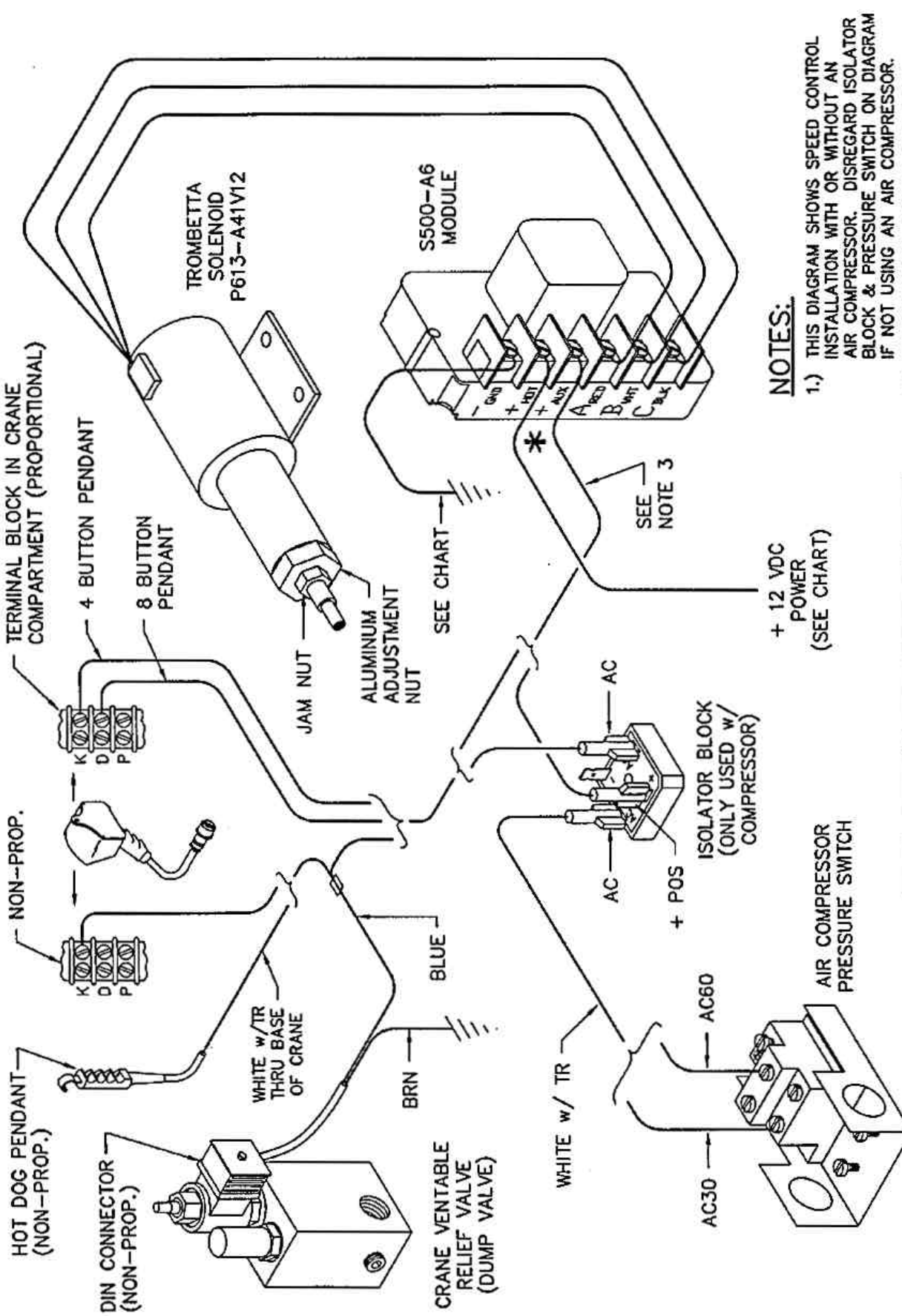

**NOTES:**

- 1.) THIS DIAGRAM SHOWS SPEED CONTROL INSTALLATION WITH OR WITHOUT AN AIR COMPRESSOR. DISREGARD ISOLATOR BLOCK & PRESSURE SWITCH ON DIAGRAM IF NOT USING AN AIR COMPRESSOR.
- 2.) REMOVE METAL JUMPER CLIP FROM CONTROL MODULE IF SO EQUIPPED (S500-A5)
- 3.) THE WIRE SIZE AND LENGTH TO "AUX" TERMINAL OF THE CONTROL MODULE IS NOT CRITICAL BECAUSE OF LOW CURRENT; 16-18 GAGE WIRE MAY BE USED.

**\* MAXIMUM TOTAL WIRE LENGTH (ft)**

Total of "-GND" and "+HOT" wire length plus "B WHIT" and "C BLK" wire length.

	12 Ga	10 Ga	8 Ga	6 Ga
12VDC	10 ft	16 ft	25 ft	40 ft

**AW-751140  
SPEED CONTROL KIT**



# ENGINE START/STOP RELAY KIT

P/N 480533

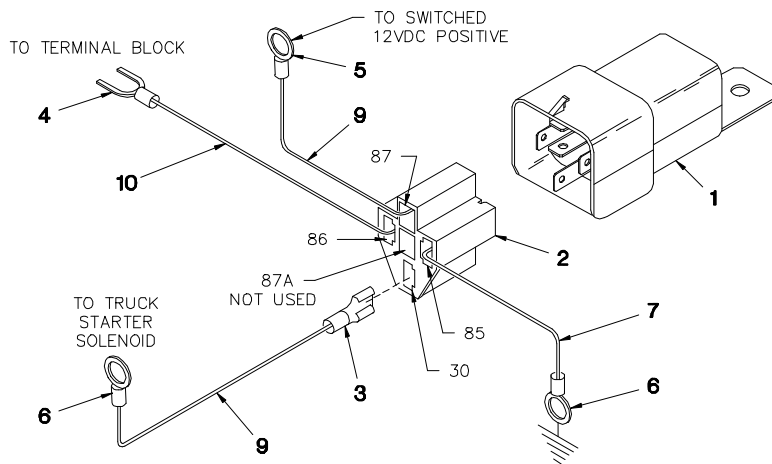

**ENGINE START RELAY**

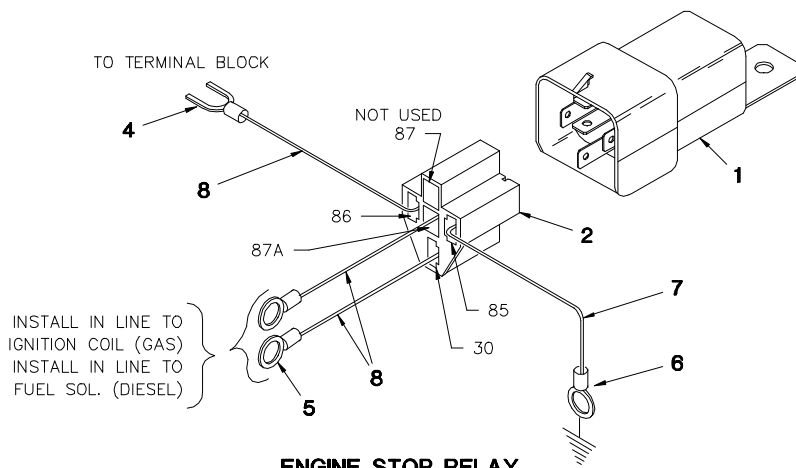

**ENGINE STOP RELAY**

<u>ITEM</u>	<u>QTY</u>	<u>P/N</u>	<u>DESCRIPTION</u>
1	2	320355	12V RELAY
2	2	320363	RELAY PLUG
3	10	320357	FEMALE SPADE LOCK CONNECTOR
4	2	480495	FLANGED SPADE TERMINAL
5	3	000402	1/4 TERMINAL RING
6	3	000501	5/16 TERMINAL RING
7	6'	800595	GREEN 16 GA WIRE
8	49'	800590	BLACK 16 GA WIRE
9	17'	800593	RED 16 GA WIRE
10	35'	800594	BLUE 16 GA WIRE

# AUXILIARY RELAY KIT

P/N 480534

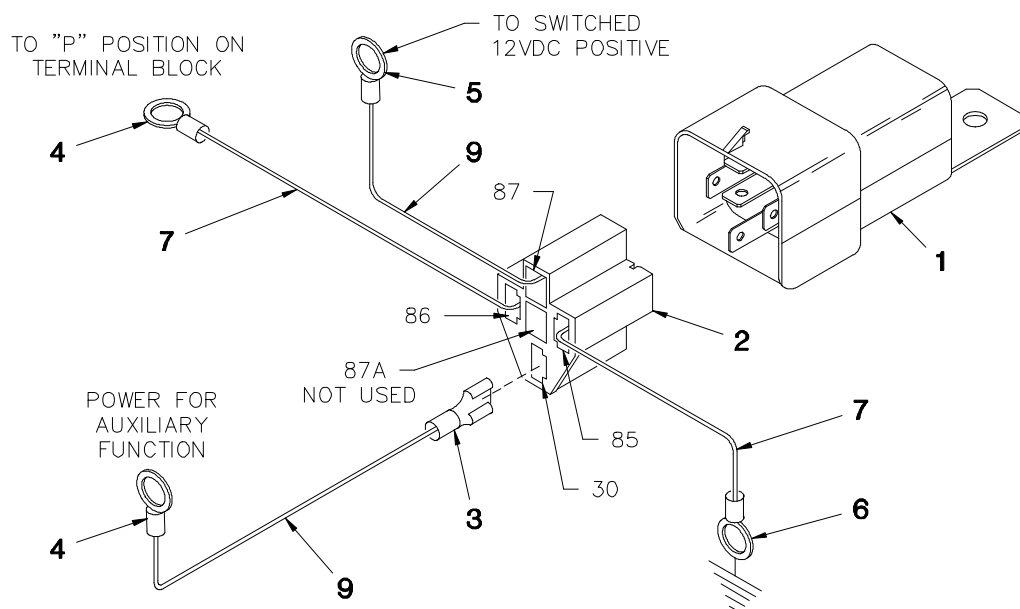

## AUXILIARY RELAY

<u>ITEM</u>	<u>QTY</u>	<u>P/N</u>	<u>DESCRIPTION</u>
1	2	320355	12V RELAY
2	2	320363	RELAY PLUG
3	5	320357	FEMALE SPADE LOCK CONNECTOR
4	2	000101	#6 TERMINAL RING
5	1	000402	1/4 TERMINAL RING
6	1	000501	5/16 TERMINAL RING
7	38'	800595	GREEN 16 GA WIRE
8	10'	800593	RED 16 GA WIRE
9	25'	800592	WHITE 16 GA WIRE

# HYDRAULICS

## 6006H

### Vented Relief Valve Setting

- { The crane must receive 8 to 9 Gallons Per Minute (GPM) and 2200 PSI. To assure proper flow, install an in-line flow meter between the crane and the reservoir in the return hose, or confirm correct pump speed (or engine speed w/ PTO ratio multiplied). Proper pressure setting for units without proportional control can be achieved by, with PTO disengaged, removing the plug, item 5,

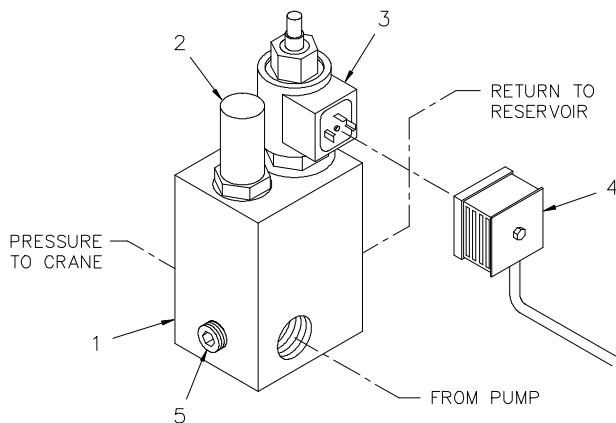

AW-157  
NON-PROPORTIONAL "DUMP VALVE"

and installing a 2500 psi gauge. Test the pressure by fully retracting the cylinder and holding Boom-In function while reading the gauge.

- { The boom can now be retracted fully and the switch held in retract position until full pressure is reached and the pressure gauge is checked. If the gauge is not 2200 PSI, adjust the vented relief valve (item 2). Verify this setting by operating the retract switch a few times and checking the pressure setting.

- { Disengage PTO. Remove gauge and reinstall the pipe plug. Crane is now ready for use.

### Proportional Relief Valve Setting

- { The crane must receive 8 to 9 Gallons Per Minute (GPM) and 2200 PSI. To assure proper flow, install an in-line flow meter between the crane and the reservoir in the return hose, or confirm correct pump speed (or engine speed w/PTO rotation multiplier).

- { Proper pressure setting for the propor-

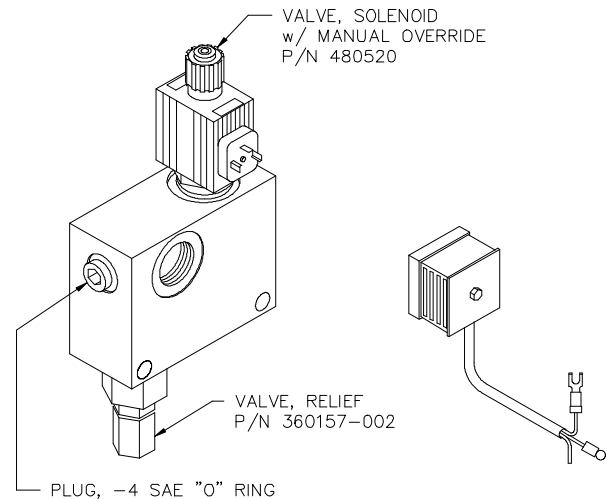

AW-525  
HYDRAULIC MANIFOLD ASSEMBLY  
PROPORTIONAL

tional control relief valve can be achieved by removing the -4 SAE plug (with PTO disengaged), and installing a 2500 PSI gauge. Test the pressure by pulling the trigger all the way back towards the handle and operating the boom down switch while reading the gauge. Double check the setting by operating the manual override located on the top of the proportional valve (using an Allen wrench or something

# HYDRAULICS

## 6006H

similar to press the steel button) and simultaneously operate the boom retract function. If the reading is higher, check the proportional system troubleshooting section of this manual to find out why the valve was not fully closing.

- { If it is the same, with PTO disengaged, remove the gauge and reinstall the plug. The crane is now ready for use.

### Counterbalance Valve Adjustment

- { With PTO disengaged and boom properly supported, remove O-ring plug (item 17) shown on AW-573 marked "X" port (see CB valve diagram). Install a pressure gauge (0-2500 PSI) into the port.
- { Engage PTO and insure pump flow is 8

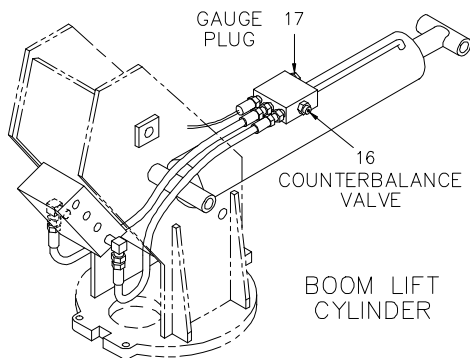

AW-573

to 9 GPM and main relief is set to 2200 PSI. With no load on boom, boom up to an angle of 70 degrees. Boom down and note pressure. If pressure reading is not approximately 1050 PSI, the counterbalance valve requires adjustment.

- v To increase the CB valve setting, loosen nut and turn Allen head screw counter clockwise. (Reference

item 16, located on the side of the CB valve block towards the right side of the boom.)

- v To reduce the CB valve setting, loosen nut and turn Allen head screw clockwise.

- { Tighten nut on adjustment screw and repeat procedure if needed to obtain the proper pressure setting.
- { Disengage PTO, remove the pressure gauge and install -6 plug. Crane is now ready for operation.

### *Notice:*

- { In an EMERGENCY situation when it becomes necessary to lower the boom without flow present, the CB valve adjustment can be turned in until the boom begins to descend. Make sure the boom will lower onto a proper support. Loosen the lock nut and carefully turn adjustment screw clockwise! Count the number of turns. *Turn slowly until the boom just begins to lower, and remove hand/arm/fingers from cranes while boom is lowering.*
- { Turning adjustment screw too far will cause valve to come apart on the inside. This condition is not repairable
- { After boom is lowered, turn adjustment screw counter clockwise the approximate number of turns made during lowering procedure. After the problem is corrected, readjust the counterbalance valve using the procedure in this manual.

### **WARNING:**

**DO NOT TRY TO ADJUST VALVES WHILE BOOM IS MOVING. Failure to do so may result in personal injury!**

---

# HYDRAULIC TROUBLESHOOTING 6006H

---

Issue Date:

October, 1994

---

**CAUTION: Never check for hydraulic leaks by feeling around hoses, fittings, or any other components. High pressure oil can be injected through the skin causing severe injury, or death.**

---

The hydraulic system of the 6006H power version is electrically operated and requires a minimum of 12V for satisfactory performance. The hydraulic pump is bi-rotational with a pressure relief setting of 2200 psi. Standard pump speed is 1000 RPM (Ref. Pump P/N 480018). This pump is for direct flange mounting only. It is not to be shaft driven unless an outboard bearing is installed, Auto Crane Kit P/N 480006.

## PROBLEM

## SOLUTION

### FLOW PRESENT BUT FUNCTION WILL NOT WORK

Remove valve cover to gain access to the manual override on the end of the valve cartridge. If the pump is operating, operate the relief valve manual override or the proportional valve override and push and twist (CCW) the directional control valve manual override to unlock, then pull to operate the function. If the function does operate, check for loose wire, low voltage or bad ground. If the problem is traced to no voltage at the valve cartridge, remove pendant and with the switch engaged, check for an open circuit with an ohmmeter. If the circuit is open, check for broken wiring or bad switch. If the function does not operate, see the "NO FLOW" paragraph in this section.

When a hydraulic function is engaged and causes the crane to "chatter", check for loose wire, low voltage at valve cartridge, low pump pressure, or air in the system.

---

### HYDRAULIC "CHATTER"

---

### NO FLOW OR LIMITED FLOW TO CRANE

Check for adequate oil supply in reservoir. Check operation of bypass system by pressing manual override on solenoid valve operator on vented relief valve or proportional valve while operating crane. If crane functions, check for 12V at vented relief valve solenoid when operating a function, or follow proportional trouble shooting procedure for the proportional valve. If low flow condition continues to exist when the manual override is operated, remove relief valve cartridge and check for dirt. Other possible causes for a low flow condition are:

1. Engine speed is too slow.
2. A blocked pressure hose from pump. This condition can be identified by excessive lugging of engine and rapid overheating of oil.
3. Collapsed or blocked suction hose to pump. This condition is usually identified by pump cavitation noise.
4. Bad pumps: a bad pump will usually have some flow but the flow will drop off rapidly as pressure increases. This condition will cause overheating of the system. A drop of four (4) or more GPM from Zero (0) PSI to Two Thousand (2000) PSI is cause for pump investigation

---

# HYDRAULIC TROUBLESHOOTING 6006H

---

Issue Date:

October, 1994

---

## PROBLEM

## SOLUTION

---

### NO PRESSURE OR TOO LOW PRESSURE

Check the sight gauge and maintain an adequate oil level in reservoir. Make sure pressure gauge is functioning correctly. Possible relief valve stuck open. Check for excessive leakage and correct. Check to ensure that pressure limit switch is correctly set.

---

### TOO HIGH FLOW

Make sure pump size is correct and pump speed is not too fast (Consult manufacturer's data sheet). Check or replace flow control. Check components for flow displacements. High flow may cause erratic valve opera-

---

### TOO HIGH PRESSURE

Make sure pressure relief valve is correctly set.

---

## CAUTION

The Auto Crane 6006H series cranes are manufactured with a standard overload protection system to prevent structural damage to the crane. When the crane load rating is exceeded, main boom down, extend out, and hoist up will not function. These operations cannot be used again until the load on the crane is reduced. Also, the main boom elevation will be limited in it's operation as the crane becomes overloaded. Attempting to raise the main boom with a load greatly exceeding the crane rating will open the main relief valve resulting in no boom movement. This problem can be resolved by moving the load closer to the crane pedestal, or reducing the load.

# ***LIFE OF WIRE LINE***

So many variable factors can cause the deterioration of wire line cable that it is not possible to determine a definite life expectancy. Some of these factors are:

- **Load being handled.**
- **Corrosive conditions.**
- **Maintenance of the unit:**
  - Keep the sheaves turning freely.
  - Maintain tension on cable to insure proper spooling.
  - Avoid kinks in cable.
  - Avoid abrasive action and contact with sharp corner.
- **Frequency of use.**

Auto Crane units, up to 2,400 pound ratings use 3/16 inch diameter galvanized pre-formed 7 x 19 aircraft cable. This cable has a working strength, when new, of 4,200 pounds. It is recommended when 1,200 pound loads are exceeded to use a two part line with a traveling block. This will ensure a 3.5 to 1 safety factor when the cable is new.

Keeping the above factor of safety in mind and knowing the kind of loads that will be handled, the user can determine by inspection of the cable as to when it should be replaced.

**Items to look for while inspecting the cables are:**

- Broken strands.
- Kinks and flattened sections.
- Corrosion and abrasion.

# ***WIRE LINE LUBRICATION***

**Lubrication of the wire line serves two important purposes:**

- Prevent corrosion.
- Reduce wear due to flexing and abrasion caused by contact with the sheaves, rollers, and cable on the drum.

## **Preparation**

Remove rust and foreign matter with a wire brush and wipe clean. Be sure cable is dry.

## **Application**

Method 1: Dip a brush into a light weight motor oil and apply. In some cases, dip a rag or a piece of sheepskin into the lubricant and swab the lubricant on to the rope.

Method 2: Apply a heavier lubricant such as a grease gun lubricant with hands while wearing leather gloves. (Leather gloves give greater protection and less penetration of the grease than canvas gloves.)

## **LUBRICATION & MAINTENANCE SCHEDULE**

### **6006H CRANE**

<b>SERVICE PERFORMED</b>	<b>DAY</b>	<b>WEEKLY</b>	<b>3 MOS</b>	<b>6 MOS</b>	<b>YEAR</b>	<b>NOTES</b>
LOAD HOOK	X					INSPECT HOOK & LATCH FOR DEFORMATION, CRACKS, & CORROSION
CABLE DRUM	X					MAKE SURE CABLE IS WOUND EVENLY ON DRUM
HOIST CABLE	X					CHECK FOR FLATTENING, KINKS, & BROKEN STRANDS, SEE MANUAL
HYD. HOSES	X					VISUAL INSPECTION
HYD. FLUID	X					CHECK FLUID LEVEL
MOUNTING BOLTS		X				CHECK-TORQUE TO 440 FT-LBS (DRY) AS REQUIRED
ROTATION RING GEAR		X				LUBE WITH MOBILETAC LL, OR LUBRIPLATE P/N 15263, OR EQUAL
SHEAVE BEARINGS		X				SEALED BEARING, REPLACE IF ROUGH OR LOOSE
ALL OTHER BOLTS		X				CHECK-TIGHTEN AS REQUIRED
BOOM PIVOTS		X				GREASE WITH MOBILPLEX EP-2 OR EQUIVALENT @ ZERKS
BOOM CYLINDER		X				CHECK AROUND CYLINDER ROD FOR EXCESS FLUID LEAKAGE
BOOM CYLINDER PINS		X				GREASE WITH MOBILPLEX EP-2 OR EQUIVALENT @ ZERKS
EXTENSION DETENT PIN		X				LUBE DETENT SPRING & BALL W/ WD-40
RETURN LINE FILTER			X			REPLACE ELEMENT
HI-PRES. FILTER			X			CLEAN AFTER FIRST WEEK, THEN EVERY 3 MONTHS (OPT EQUIP)
ROTATION BEARING			X			GREASE WITH MOBILPLEX EP-2 OR EQUIVALENT @ ZERKS
ROTATION BEARING BOLTS			X			CHECK TORQUE TO 150 FT-LBS (DRY) AS REQUIRED



## **LUBRICATION & MAINTENANCE SCHEDULE**

### **6006H CRANE**

SERVICE PERFORMED	DAY	WEEKLY	3 MOS	6 MOS	YEAR	NOTES
ROTATION GEAR BOX			X			CHECK TORQUE TO 85 FT-LBS (DRY) AS REQUIRED
ROTATION GEAR BOX				X		EP GEAR LUBE SAE 140
HOIST GEARBOX				X		EP GEAR-EP GEAR LUBE SAE 80-90, SPUR GEAR SAE 30 OIL
HYDRAULIC FLUID					X	DRAIN, FLUSH, AND REFILL WITH DTE 13, OR EQUIVALENT
BOOM SLIDE PADS	PADS GREASED WHEN REPLACED					
FOR ADDITIONAL INFORMATION SEE:	1) OWNER'S MANUAL 2) OSHA SECTION 1910.180 3) ANSI B30.5-1989					

**CAUTION: Routine maintenance insures trouble-free operation and protects your investment. All warranties are void if maintenance is neglected.**

#### **NOTES:**

1. Use only authorized parts. Any damage or malfunction caused by the use of unauthorized parts is not covered by Warranty or Product Liability.
2. Once a bolt has been torqued to its rated capacity and then removed; the bolt should be replaced with a new one.
3. Auto Crane Company recommends that this crane be serviced per "Crane Inspection Log" P/N 999978. These logs should be filled in at the intervals noted and kept as a permanent record. Additional copies are available from your local distributor.

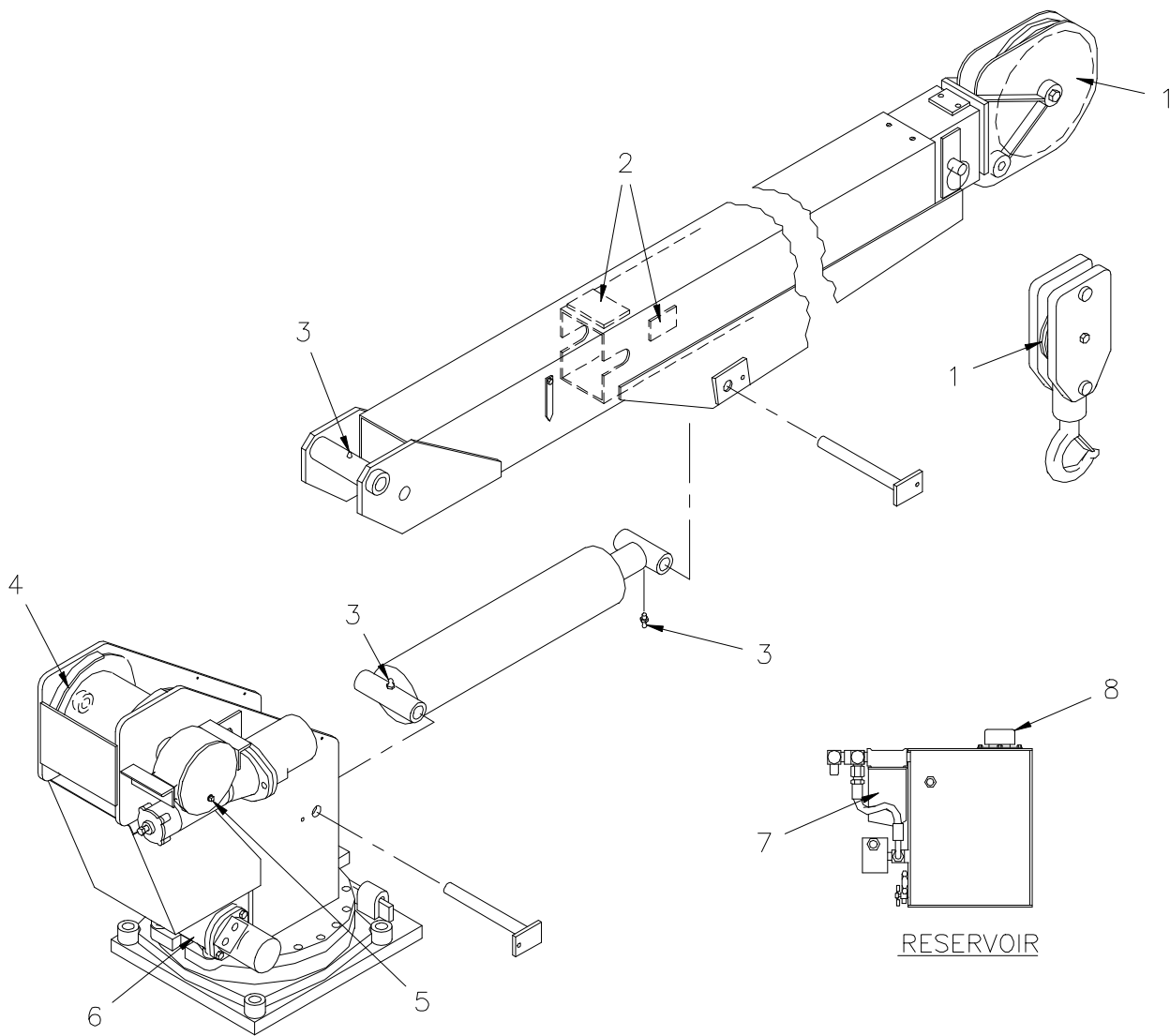

1. SHEAVE ROLLER BEARINGS:  
SEALED TYPE, NO LUBE REQUIRED.

2. BOOM PADS:  
IF REPLACED, GREASE UPON INSTALLATION WITH  
CHASSIS LUBRICANT.

3. PIVOT POINT GREASE ZERKS:  
LUBE ONCE A WEEK WITH MOBILPLEX EP-2  
OR EQUIVALENT.

4. HOIST ROLLER BEARINGS:  
SEALED TYPE, NO LUBE REQUIRED.

5. HOIST ACTUATOR:  
MAINTAIN GEAR BOX LUBRICANT AT FILL PLUG.  
USE ONE PINT OF EP GEAR LUBE SAE 80-90.  
REPLACE EVERY SIX MONTHS.

6. ROTATION ACTUATOR:  
MAINTAIN OIL LEVEL OF 1 1/2 PINTS OF  
EP GEAR LUBE, SAE 140.  
REPLACE EVERY SIX MONTHS.

7. RESERVOIR FILTER:  
10 MICRON SPIN ON FILTER REQUIRED. REPLACE  
EVERY THREE MONTHS. SEE RESERVOIR ASSEMBLY  
FOR PART NUMBER.

8. HYDRAULIC FLUID:  
USE DTE-13 OR EQUIVALENT. KEEP LEVEL AT  
SIGHT GAUGE. RESERVOIR SHOULD BE FLUSHED  
AND NEW FLUID ADDED ONCE A YEAR, OR IF  
A HYDRAULIC FAILURE OCCURS.

## AW-074 LUBRICATION MAINTENANCE

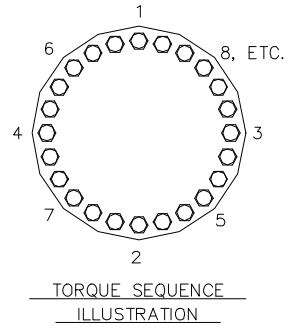
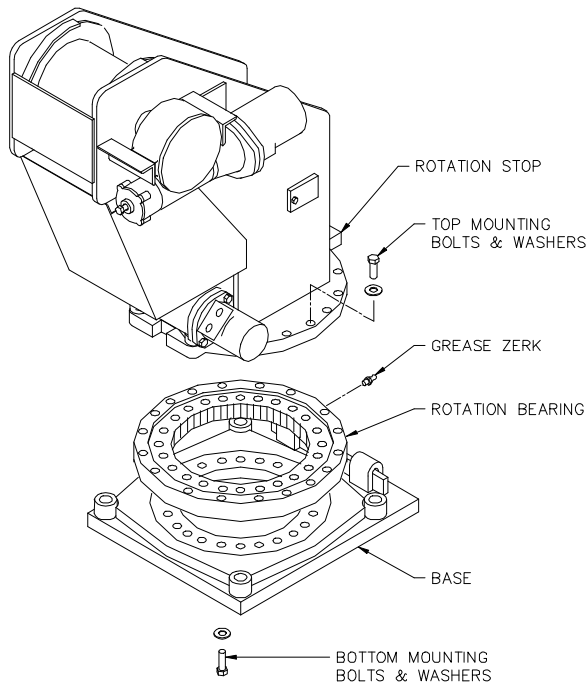

LUBRICATION OF ROTATION BEARING

INSTALLATION OF ROTATION BEARING

RACE

1. LUBRICATE BEARING RACE AT THE GREASE ZERK LOCATED ON THE OUTSIDE OF THE ROTATION BEARING DIRECTLY UNDER THE ROTATION STOP OF THE PEDESTAL.
2. LISTED IN THE CHART BELOW ARE SEVERAL LUBRICANTS WHICH ARE ACCEPTABLE FOR BOTH RUST INHIBITING AND EXTREME PRESSURE CHARACTERISTICS.
  - A. LUBRICATE THE BEARING DAILY IF THE CRANE IS USED ON A DAILY BASIS.
  - B. LUBRICATE THE BEARING EVERY 30 DAYS IF THE CRANE IS USED INTERMITTENTLY.
  - C. ROTATE THE BEARING THROUGH TWO OR MORE ROTATIONS DURING LUBRICATION PROCESS.

GEAR

1. THE CHART BELOW LISTS SEVERAL LUBRICANTS FOR THE GEAR. IT IS RECOMMENDED THAT THE TEETH BE LUBRICATED WITH A SMALL AMOUNT OF GREASE EVERY 8 HOURS IF THE CRANE IS USED DAILY. THE GREASE IS PURGED FROM THE TEETH BY THE VERY NATURE OF BEING EXPOSED TO THE ELEMENTS. THEREFORE CLOSE ATTENTION TO THE GEAR LUBRICANT WILL PROVIDE A LONGER TOOTH LIFE. GREASE THE GEAR TEETH AT THE PINION LOCATION.

1. MAKE SURE MOUNTING SURFACES ARE FLAT AND CLEAR OF DEBRIS.
2. INSTALL BEARING SUCH THAT THE GREASE ZERK ON THE BEARING IS LOCATED DIRECTLY UNDER THE ROTATION STOP OF THE PEDESTAL.
3. INSTALL TOP AND BOTTOM BOLTS AND FLAT WASHERS. ALL BOLTS MUST BE GRADE 8 AND USED WITH HARDENED FLAT WASHERS. REFER TO PEDESTAL ASSEMBLY FOR PART NUMBERS.
4. SNUG ALL BOLTS , THEN TIGHTEN ACCORDING TO THE TORQUE SEQUENCE ILLUSTRATION UNTIL ALL BOLTS ARE TORQUED TO 150 FT.-LBS (NON-PLATED) OR 110 FT.-LBS (PLATED).

NOTE: BOLTS SHOULD BE CHECKED PERIODICALLY AND RETIGHTENED TO PROPER TORQUE.

5. GREASE THE ROTATION BEARING ACCORDING TO LUBRICATION INSTRUCTIONS AT LEFT.
6. SET BACKLASH OF THE ROTATION ACTUATOR AND THE ROTATION BEARING AT THE HIGH POINT OF THE ROTATION BEARING GEAR TEETH. IDENTIFIED BY A YELLOW PAINT MARK ON THE TEETH.

	MOBIL	TEXACO	SUNOCO	PURE	SOHIO
RACE	MOBILPLEX EP #2	MARFAC MP #2	PRESTIGE 742EP	POCO HT EP #2	SOHITRAN EP #1
GEAR	MOBILCOTE-S	CRATER COMPOUND	407 COMPOUND B	POCO GEARSHIELD	SOHITAC #1

AW-124  
ROTATION BEARING MAINTENANCE

# PEDESTAL ASSEMBLY

P/N 366010 - 6006H

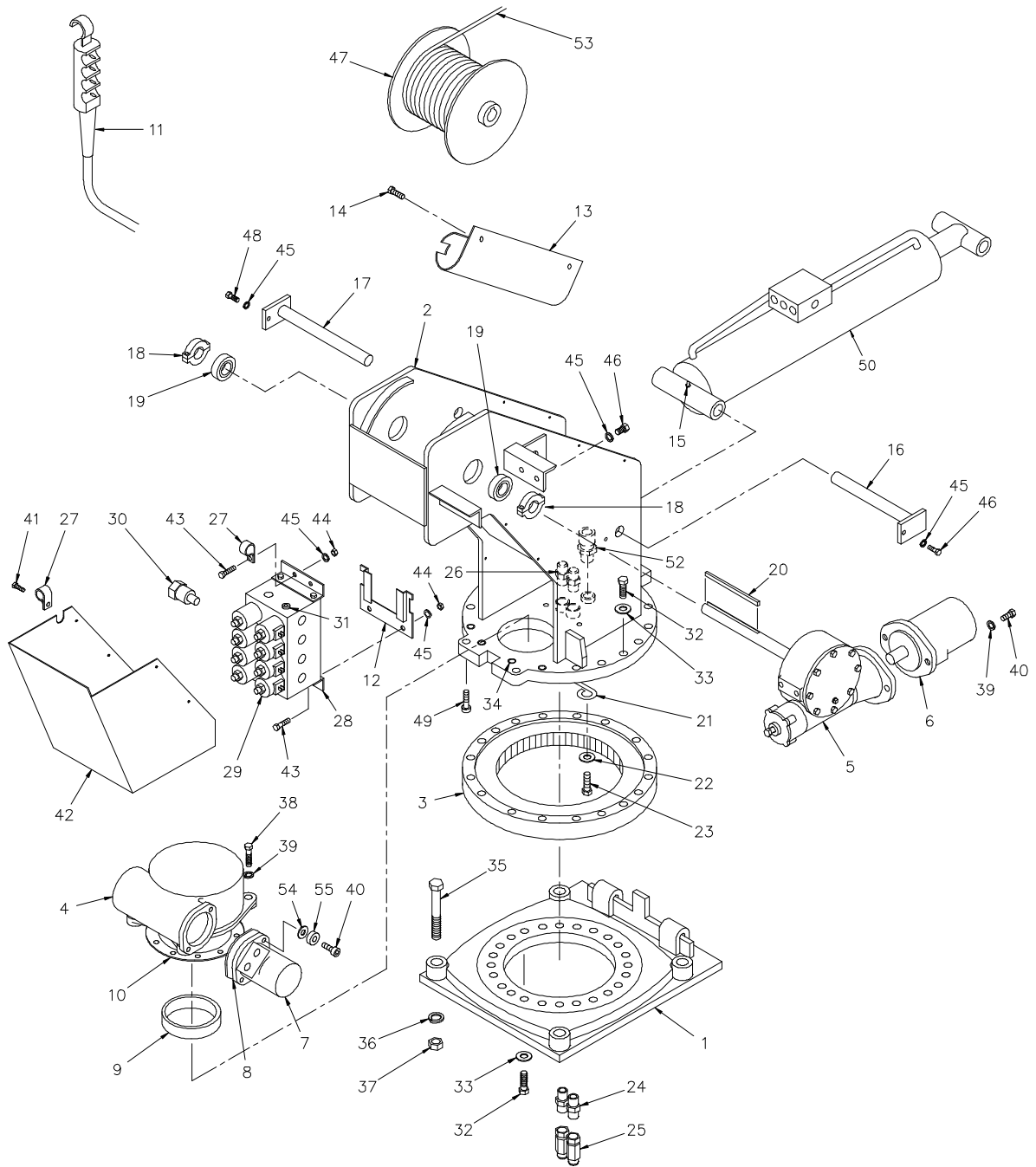

# ***PEDESTAL ASSEMBLY***

***P/N 366010 - 6006H***

<b><u>ITEM</u></b>	<b><u>QTY</u></b>	<b><u>P/N</u></b>	<b><u>DESCRIPTION</u></b>
1	1	360536	BASE PLATE ASSEMBLY
2	1	366045	PEDESTAL WELDMENT
3	1	480023-002	ROTATION BEARING
4	1	480028	ROTATION GEAR BOX
5	1	480075	HOIST ACTUATOR
6	1	480076	HYDRAULIC HOIST MOTOR
7	1	480027	HYDRAULIC ROTATION MOTOR
8	1	480019	MOTOR GASKET
9	1	360162	ECCENTRIC RING
10	1	480011	ROTATION BOX SEAL
11	1	480093	4 FUNCTION PENDANT
12	1	366987	RELAY BOX ASSEMBLY RETAINING CLIP
13	1	634000	PENDANT GUARD
14	2	002615	SCREW 1/4-20 NC x 3/8 SELF-TAPPING
15	2	239000	GREASE ZERK
16	1	366191	PEDESTAL/CYLINDER PIN
17	1	366192	LOWER BOOM PIVOT PIN
18	2	330468	SPLIT LOCK COLLAR
19	2	400500	BEARING
20	1	480094	KEY 3/8 SQ
21	1	360207	ECCENTRIC RING RETAINER
22	1	020600	WASHER SP LK 5/16
23	1	007807	SCREW HEX HD 5/16 NC x 3/4 GR5
24	2	750413	REDUCER -8 NPT/-6 NPTF
25	2	750412	SWIVEL JOINT -8
26	2	360054	ADAPTER -8 NPT/-8 JIC
27	1	480024	PENDANT RETAINER MOUNT
28	1	480182	CARTRIDGE MANIFOLD
29	8	480184	CARTRIDGE VALVE
30	1	480183	FLOW REGULATOR CARTRIDGE
31	1	000109	PIPE PLUG 3/8
32	38	012198	HEX HD SCREW 5/8-16 NC x 1 3/4 GR8
33	38	023902	WASHER FLAT 5/8 HARDENED
34	4	006205	SOC HD SCREW 5/8-16 NC x 1 1/4 GR8
35	4	015104	HEX HD SCREW 7/8 NF x 5 GR8

# ***PEDESTAL ASSEMBLY***

***P/N 366010 - 6006H***

<b><u>ITEM</u></b>	<b><u>QTY</u></b>	<b><u>P/N</u></b>	<b><u>DESCRIPTION</u></b>
36	4	022200	LOCKWASHER 7/8
37	4	018900	HEX NUT 7/8 NF
38	2	011608	HEX HD SCREW 1/2 NC x 2 GR5
39	4	021500	WASHER SP LK 1/2
40	4	012197	SOC HD SCREW 1/2 NC x 1 1/2 GR5
41	6	002608	SCREW 1/4-20 x 3/4 ST TYPE F
42	1	360544	VALVE COVER
43	4	330394	HEX HD SCREW 3/8 NC x 1 1/2
44	4	017100	HEX NUT 3/8 NC
45	10	021100	WASHER SP LK 3/8
46	6	330370	HEX HD SCREW 3/8 NC x 7/8 GR8
47	1	366180	HOIST DRUM
48	1	366158	HEX HD SCREW 3/8 NC x 3/4 GR8
49	2	009118	SOC HD SCREW 1/2 NC x 2 GR5
50	1	366805	BOOM UP CYLINDER
51	1	366544	SEAL KIT
52	1	370433	CONNECTOR CABLE
53	1	480031	3/8 HOIST CABLE
54	2	021502	WASHER SP LK 1/2 (HI-COLLAR)
55	2	021601	WASHER FLAT 1/2 SAE (SPECIAL)

# PEDESTAL ASSEMBLY

P/N 366131 - 6006H

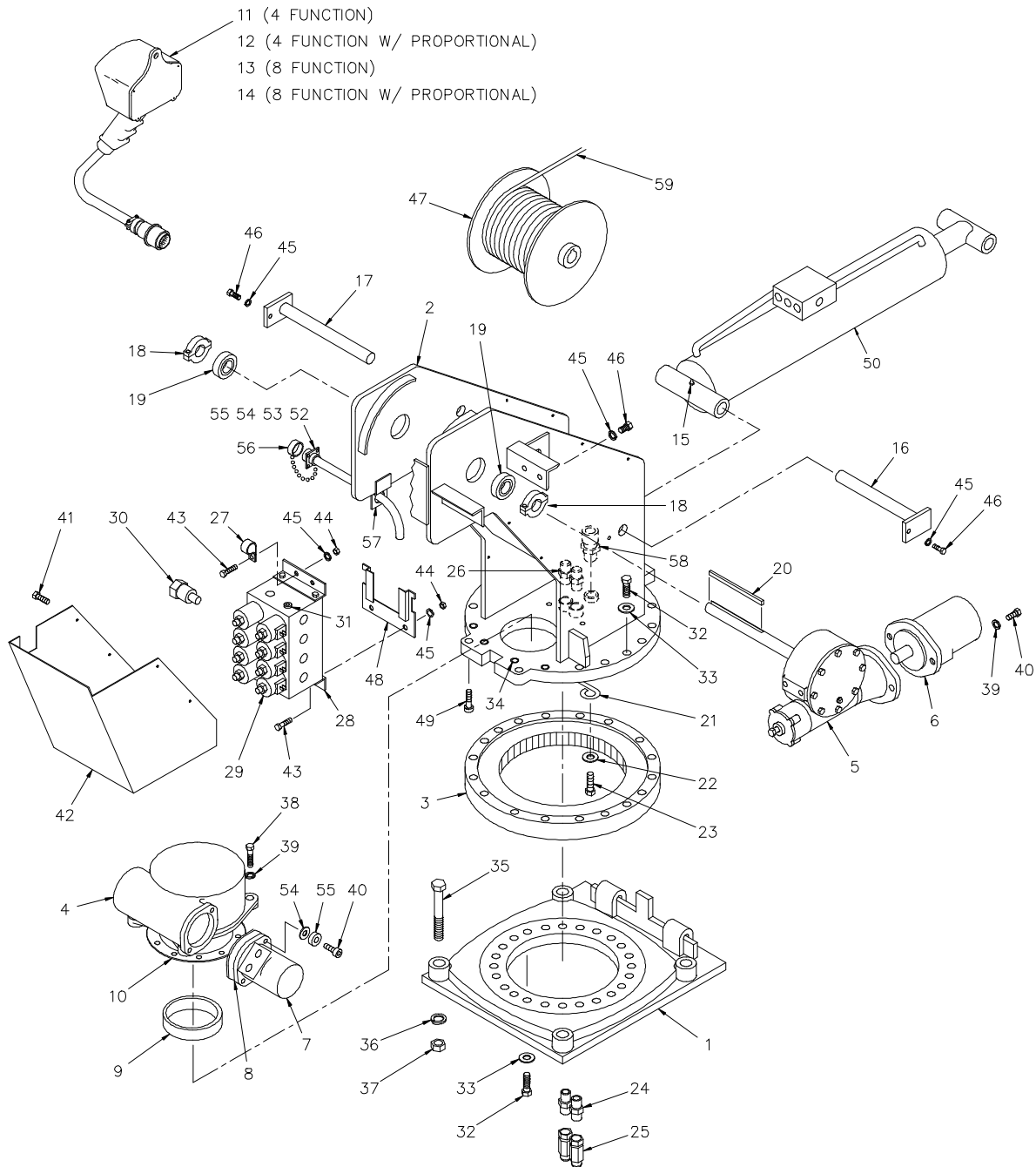

# ***PEDESTAL ASSEMBLY***

***P/N 366131 - 6006H***

<b><u>ITEM</u></b>	<b><u>QTY</u></b>	<b><u>P/N</u></b>	<b><u>DESCRIPTION</u></b>
1	1	360536	BASE PLATE ASSEMBLY
2	1	366045	PEDESTAL WELDMENT
3	1	480023-002	ROTATION BEARING
4	1	480028	ROTATION GEAR BOX
5	1	480075	HOIST ACTUATOR
6	1	480076	HYDRAULIC HOIST MOTOR
7	1	480027	HYDRAULIC ROTATION MOTOR
8	1	480019	MOTOR GASKET
9	1	360162	ECCENTRIC RING
10	1	480011	ROTATION BOX SEAL
11	1	680037	4 FUNCTION PENDANT
12	1	680038	4 FUNCTION PENDANT w/ PROPORTIONAL
13	1	680039	8 FUNCTION PENDANT
14	1	680040	8 FUNCTION PENDANT w/ PROPORTIONAL
15	2	239000	GREASE ZERK
16	1	366191	PEDESTAL/CYLINDER PIN
17	1	366192	LOWER BOOM PIVOT PIN
18	2	330468	SPLIT LOCK COLLAR
19	2	400500	BEARING
20	1	480094	KEY 3/8 SQ
21	1	360207	ECCENTRIC RING RETAINER
22	1	020600	WASHER SP LK 5/16
23	1	007807	SCREW HEX HD 5/16 NC x 3/4 GR5
24	2	750413	REDUCER -8 NPT/-6 NPTF
25	2	750412	SWIVEL JOINT -8
26	2	360054	ADAPTER -8 NPT/-8 JIC
27	1	480024	PENDANT RETAINER MOUNT
28	1	480182	CARTRIDGE MANIFOLD
29	8	480184	CARTRIDGE VALVE
30	1	480183	FLOW REGULATOR CARTRIDGE
31	1	000109	PIPE PLUG 3/8
32	38	012198	HEX HD SCREW 5/8-16 NC x 1 3/4 GR8
33	38	023902	WASHER FLAT 5/8 HARDENED
34	4	006205	SOC HD SCREW 5/8-16 NC x 1 1/4 GR8
35	4	015104	HEX HD SCREW 7/8 NF x 5 GR8



# ***PEDESTAL ASSEMBLY***

***P/N 366131 - 6006H***

<b><u>ITEM</u></b>	<b><u>QTY</u></b>	<b><u>P/N</u></b>	<b><u>DESCRIPTION</u></b>
36	4	022200	LOCKWASHER 7/8
37	4	018900	HEX NUT 7/8 NF
38	2	011608	HEX HD SCREW 1/2 NC x 2 GR5
39	4	021500	WASHER SP LK 1/2
40	4	012197	SOC HD SCREW 1/2 NC x 1 1/2 GR5
41	6	002608	SCREW 1/4-20 x 3/4 ST TYPE F
42	1	480403	VALVE COVER w/ NOTCH
43	4	330394	HEX HD SCREW 3/8 NC x 1 1/2
44	4	017100	HEX NUT 3/8 NC
45	10	021100	WASHER SP LK 3/8
46	6	330370	HEX HD SCREW 3/8 NC x 7/8 GR8
47	1	366180	HOIST DRUM
48	1	366987	RELAY BOX ASSEMBLY RETAINING CLIP
49	2	009118	SOC HD SCREW 1/2 NC x 2 GR5
50	1	366805	BOOM UP CYLINDER
51	1	366544	SEAL KIT
52	1	680044	RECEPTACLE ASSEMBLY
53	2	000404	SCREW #6-32 x 5/8
54	2	019600	WASHER SP LK #6
55	2	015400	NUT HEX #6-32
56	1	366097	RECEPTACLE CAP
57	1	480410	BRACKET
58	1	370433	CONNECTOR CABLE
59	1	480031	3/8 HOIST CABLE
60	2	021502	WASHER SP LK 1/2 (HI-COLLAR)
61	2	021601	WASHER FLAT 1/2 SAE (SPECIAL)

# PEDESTAL ASSEMBLY IN COMPARTMENT (IC) PENDANT

P/N 366148 - 6006H

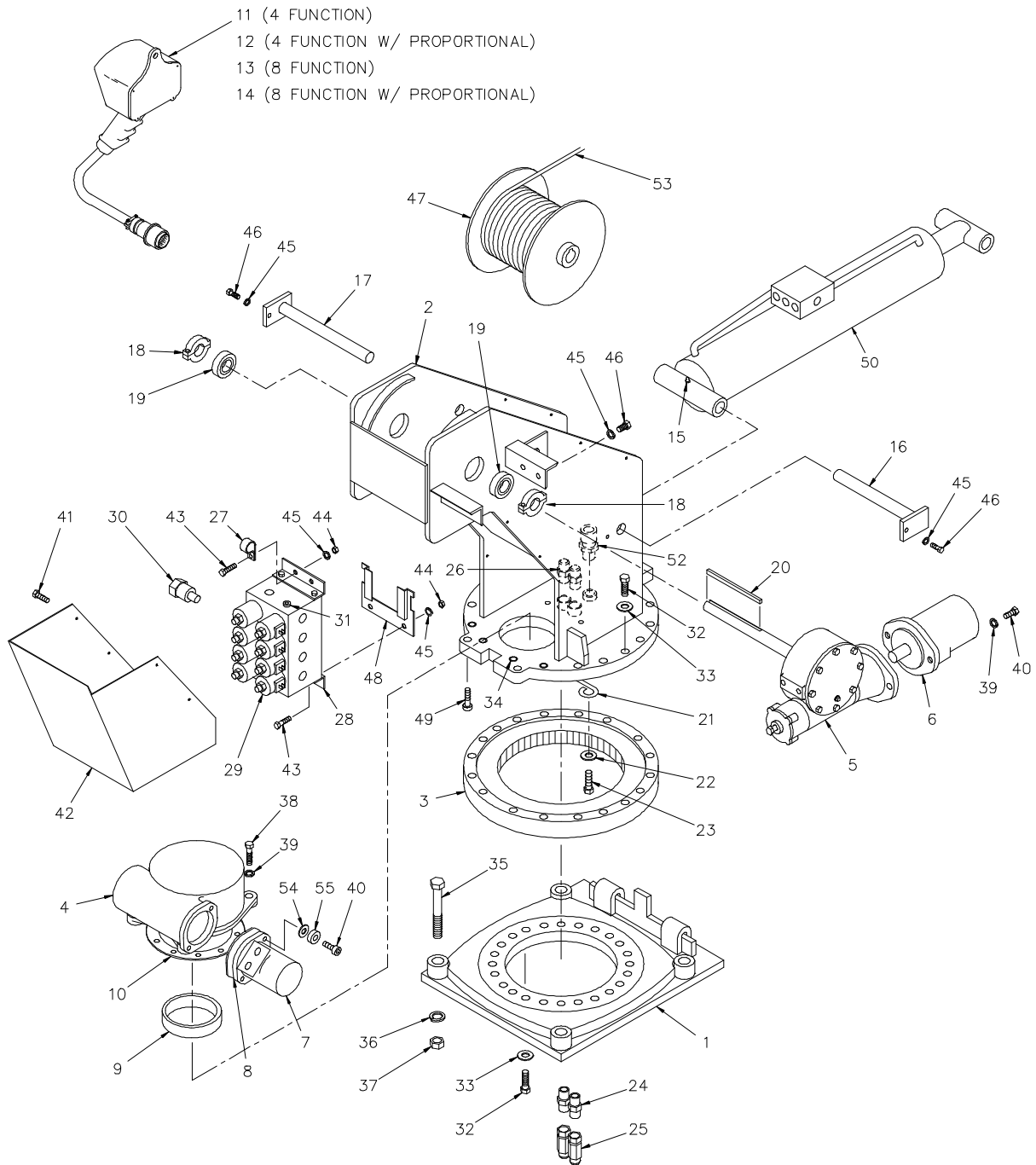

**PEDESTAL ASSEMBLY IN COMPARTMENT (IC)  
PENDANT**

**P/N 366148 - 6006H**

<u>ITEM</u>	<u>QTY</u>	<u>P/N</u>	<u>DESCRIPTION</u>
1	1	360536	BASE PLATE ASSEMBLY
2	1	366045	PEDESTAL WELDMENT
3	1	480023-002	ROTATION BEARING
4	1	480028	ROTATION GEAR BOX
5	1	480075	HOIST ACTUATOR
6	1	480076	HYDRAULIC HOIST MOTOR
7	1	480027	HYDRAULIC ROTATION MOTOR
8	1	480019	MOTOR GASKET
9	1	360162	ECCENTRIC RING
10	1	480011	ROTATION BOX SEAL
11	1	680037	4 FUNCTION PENDANT
12	1	680038	4 FUNCTION PENDANT w/ PROPORTIONAL
13	1	680039	8 FUNCTION PENDANT
14	1	680040	8 FUNCTION PENDANT w/ PROPORTIONAL
15	2	239000	GREASE ZERK
16	1	366191	PEDESTAL/CYLINDER PIN
17	1	366192	LOWER BOOM PIVOT PIN
18	2	330468	SPLIT LOCK COLLAR
19	2	400500	BEARING
20	1	480094	KEY 3/8 SQ
21	1	360207	ECCENTRIC RING RETAINER
22	1	020600	WASHER SP LK 5/16
23	1	007807	SCREW HEX HD 5/16 NC x 3/4 GR5
24	2	750413	REDUCER -8 NPT/-6 NPTF
25	2	750412	SWIVEL JOINT -8
26	2	360054	ADAPTER -8 NPT/-8 JIC
27	1	480024	PENDANT RETAINER MOUNT
28	1	480182	CARTRIDGE MANIFOLD
29	8	480184	CARTRIDGE VALVE
30	1	480183	FLOW REGULATOR CARTRIDGE
31	1	000109	PIPE PLUG 3/8
32	38	012198	HEX HD SCREW 5/8-16 NC x 1 3/4 GR8
33	38	023902	WASHER FLAT 5/8 HARDENED
34	4	006205	SOC HD SCREW 5/8-16 NC x 1 1/4 GR8
35	4	015104	HEX HD SCREW 7/8 NF x 5 GR8

***PEDESTAL ASSEMBLY IN COMPARTMENT (IC)  
PENDANT***

***P/N 366148 - 6006H***

<u>ITEM</u>	<u>QTY</u>	<u>P/N</u>	<u>DESCRIPTION</u>
36	4	022200	LOCKWASHER 7/8
37	4	018900	HEX NUT 7/8 NF
38	2	011608	HEX HD SCREW 1/2 NC x 2 GR5
39	4	021500	WASHER SP LK 1/2
40	4	012197	SOC HD SCREW 1/2 NC x 1 1/2 GR5
41	6	002608	SCREW 1/4-20 x 3/4 ST TYPE F
42	1	360544	VALVE COVER
43	4	330394	HEX HD SCREW 3/8 NC x 1 1/2
44	4	017100	HOIST DRUM
45	10	021100	WASHER SP LK 3/8
46	6	330370	HEX HD SCREW 3/8 NC x 7/8 GR8
47	1	366180	HOIST DRUM
48	1	366987	RELAY BOX ASSEMBLY RETAINING CLIP
49	2	009118	SOC HD SCREW 1/2 NC x 2 GR5
50	1	366805	BOOM UP CYLINDER
51	1	366544	SEAL KIT
52	1	370433	CONNECTOR CABLE
53	1	480031	3/8 HOIST CABLE
54	2	021502	WASHER SP LK 1/2 HI-COLLAR
55	2	021601	WASHER FLAT 1/2 SAE SPECIAL

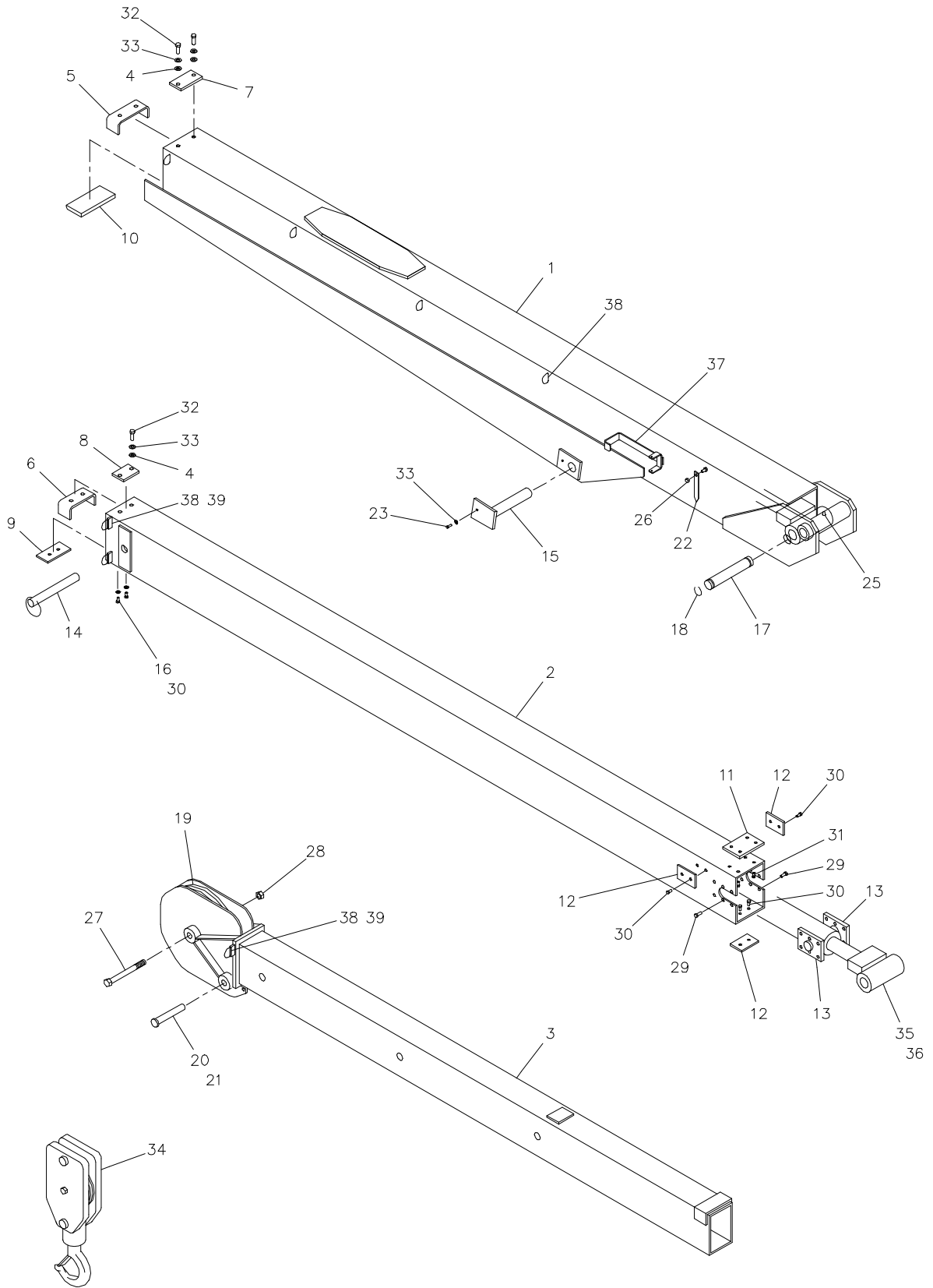

AW-480584  
6006H BOOM ASSEMBLY

AW-480584  
6006H BOOM ASSEMBLY

ITEM	QTY.	PART NO.	DESCRIPTION
1	1	480581	BOOM, LOWER (SEE NOTE 1)
2	1	366080	BOOM, CENTER
3	1	366110	BOOM, MANUAL
4	6	021200	WASHER, FLAT 3/8
5	1	366183	STOP, CENTER
6	1	366112	STOP, UPPER BOOM
7	1	366201	PAD, BOOM TOP
8	1	366202	PAD, BOOM TOP
9	1	366199	PAD, BOOM
10	1	366187	PAD, RETAINER LOWER
11	1	366185	PAD, BOOM (CENTER BOOM)
12	3	366186	PAD, BOOM (CENTER BOOM)
13	2	366184	RETAINER, EXTENSION CYLINDER
14	1	366190	PIN, ASSEMBLY w/ LANYARD
15	1	366189	PIN, BOOM CYLINDER
16	2	020600	WASHER, SP. LK. 5/16
17	1	366193	PIN, EXTENSION CYLINDER
18	2	480029	RING, RETAINING
19	1	366198	SHEAVE ASSEMBLY 3/8 (BEARING ONLY - 366197)
20	1	360125	PIN, BLOCK
21	1	360124	PIN, HITCH
22	2	360038	ANGLE INDICATOR
23	1	366158	SCREW, HEX HD. 3/8-16NC x 3/4 LG. GR.8
24	.	.	.
25	1	239000	GREASE ZERK
26	2	016300	NUT, HEX LOCK 1/4-20NC
27	1	014304	SCREW, HEX HD. 3/4-16NF x 6" LG. GR.5
28	1	018600	NUT, HEX LOCK 3/4-16NF
29	12	008400	SCREW, HEX HD. 3/8-16NC x 3/4 LG.
30	8	007808	SCREW, HEX HD. 5/16-24NF x 1/2 LG.
31	4	005406	SCREW, HEX HD. 1/4-28NF x 1/2 LG.
32	4	008800	SCREW, HEX HD. 3/8-24NF x 1" LG.
33	6	021100	WASHER, SP. LK. 3/8
34	1	366203	TRAVELING BLOCK
35	1	366162	CYLINDER, EXTENSION (COMPLETE)
	-	366162-001	CASE ASSEMBLY
	-	366162-002	SHAFT ASSEMBLY
	-	366162-003	HEAD GLAND
	-	366162-004	PISTON
36	1	366166	SEAL KIT
37	1	REF.	CORD REEL BRACKET (320551)
38	7	REF.	D-RING (366108)
39	3	REF.	SPACER (800246-025)
<u>NOTES:</u>			
1.) BOOM 366070 HAS HOOKS FOR PENDANT CABLE. BOOM 480581 IS EXACTLY THE SAME LESS THE HOOKS AND IS USED FOR PROPORTIONAL UNITS.			

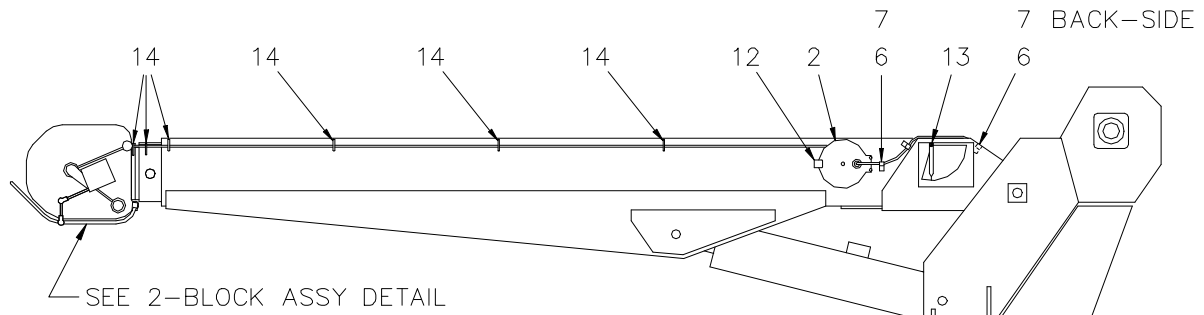

8005H CORD REEL &  
2-BLOCK ASSY

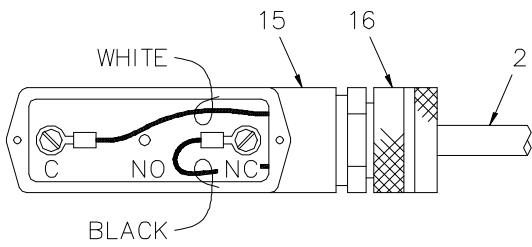

REFERENCE-SWITCH WIRING

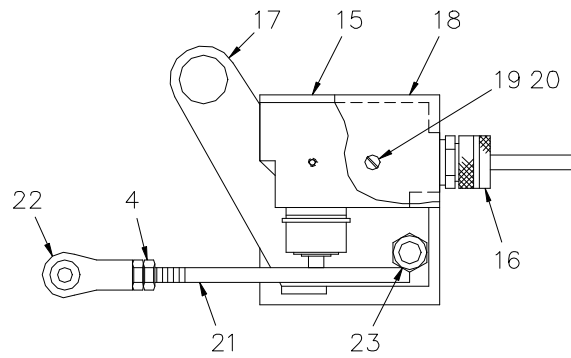

SWITCH ASSY DETAIL

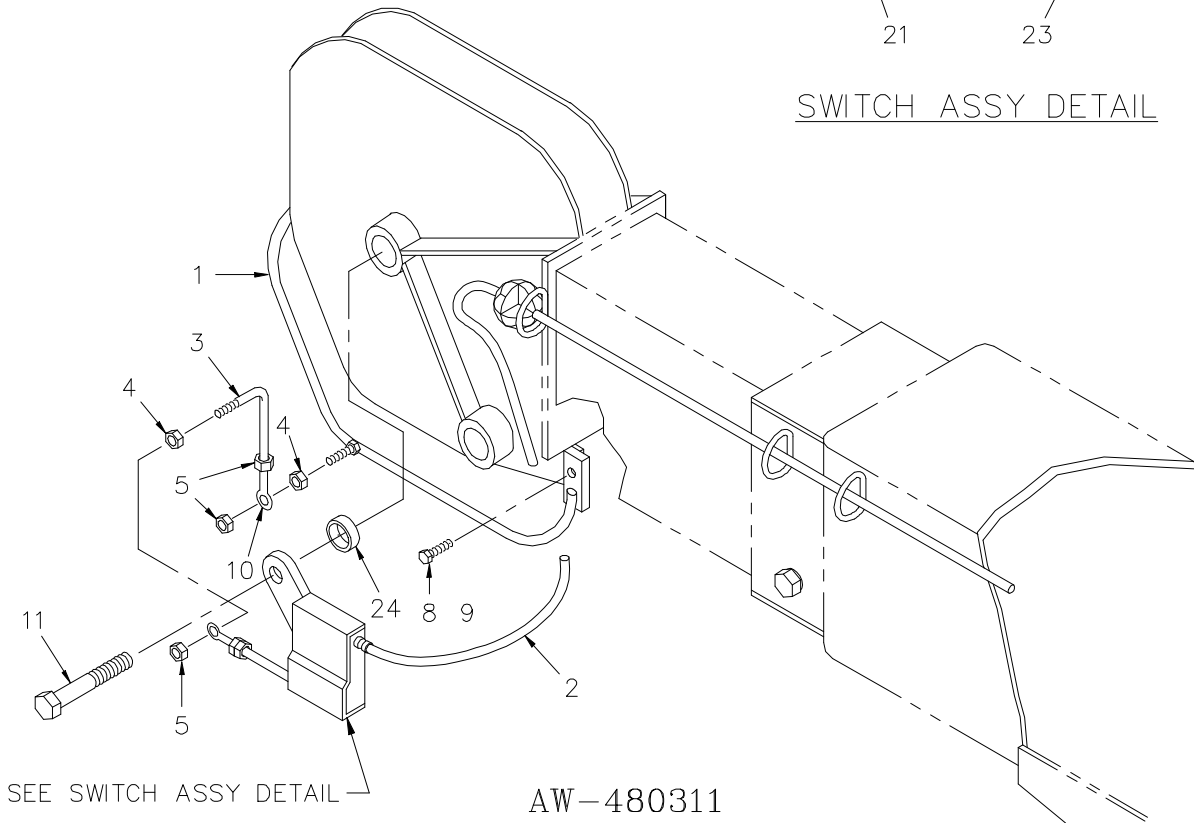

AW-480311  
2-BLOCK ASSY DETAIL

2-BLOCK ASSEMBLY AW-480311

ITEM	QTY.	PART NO.	DESCRIPTION
1	1	366116-001	BAIL, 2-BLOCK CROWN BRACKET
2	1	366973-001	CORD REEL ASSY
3	1	366196	2-BLOCK ARM
4	4	016100	NUT, HEX HD. 1/4-28 NF
5	3	016200	NUT, HEX LOCK 1/4-28 NF
6	3	002608	SCREW, HEX HD. SELF TAPPING 1/4-20 NC x 3/4 LG.
7	3	000115	CLIP, #15
8	1	007803	SCREW, HEX HD. 5/16-18 NC x 3 1/2 LG.
9	1	016801	NUT, HEX LOCK 5/16-18 NC
10	1	363006	BEARING, ROD END
11	1	REF.	SCREW, HEX HD. 3/4-16 NF x 6" LG.
12	1	320551	BRACKET, REEL MOUNT
13	2	005901	SCREW, 1/4-20 NC x 1/2 LG.
14	6	366108	D-RING
15	1	646900	SWITCH
16	1	642908	CORD CONNECTOR
17	1	363013-001	MOUNTING PLATE ASSY
18	1	363004	COVER, SWITCH
19	2	002602	SCREW, RD. HD. #6-32 NC x 1 1/4 LG.
20	2	019600	WASHER, SP. LK. #6
21	1	363005	LINKAGE, WELDMENT ROD
22	1	363006	BEARING, ROD END
23	1	017301	NUT, HEX LOCK 3/8-16 NC
24	1	480009	SPACER 1 1/8 X .120W X 3/8 LG.



# ***AUTOMATIC SAFETY BRAKE ASSEMBLY***

## ***(OIL COOLED) HOIST***

### **ASSEMBLY INSTRUCTIONS:**

1. Winch has right hand worm and gear. Cable spools over drum. Use number one slots for brake balls(7) in cam plate(2).
2. Install brake hub(5) through brake housing(4) on winch worm with key.
3. Assemble balls(7) in cam plate(2) using hard grease to hold balls in place.
4. Place cam plate(2) on brake hub(5), matching its holes with the balls.
5. Install thrust plate(16).
6. Thread capscrew(10) with jam nut (12) and thread seal (11) through housing cover(3).
7. Place gasket(15) on housing cover(3).
8. Install coil spring(9) on capscrew(10).
9. Install flat spring(1) on capscrew(10).
10. Secure retainer plate(6) and flat spring(1) to housing cover(3) using capscrews(8) and washers(14).
11. Using capscrews(8) and thread seals(13) attach housing cover(3) to brake housing(4).
12. Test brake by shifting winch to UP then DOWN to see if brake is working in proper rotation. If not, remove housing cover(3) and locate brake balls(7) in opposite set of slots of cam plate(2).
13. Adjust to suit by tightening or loosening capscrew(10) on outside of housing cover(3). When proper adjustment is obtained, secure capscrew(10) with jam nut(12).

# AUTOMATIC SAFETY BRAKE ASSEMBLY (OIL COOLED) HOIST

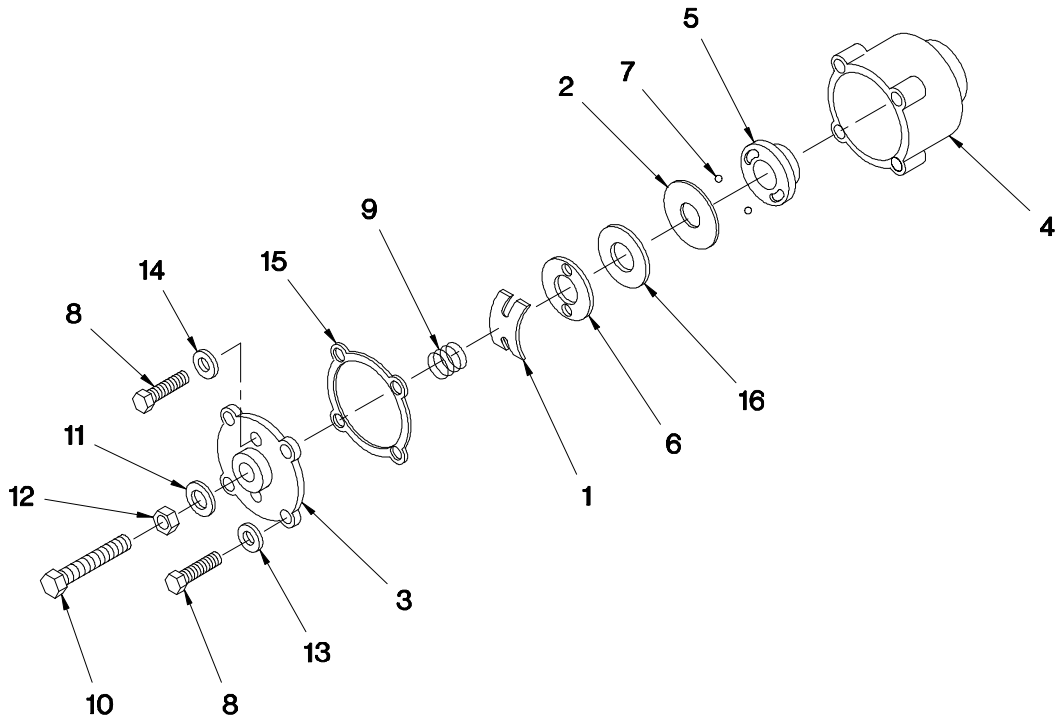

<u>ITEM</u>	<u>QTY</u>	<u>P/N</u>	<u>DESCRIPTION</u>
1	1	360367	FLAT SPRING
2	1	360331	CAM PLATE
3	1	360450	HOUSING COVER
4	1	360336	BRAKE HOUSING
5	1	360339	BRAKE HUB
6	1	360342	RETAINER PLATE
7	2	360345	BRAKE BALL
8	6	360453	CAPSCREW 1/4 NC x 1
9	1	360368	COIL SPRING
10	1	360456	CAPSCREW 3/8 NC x 1 1/2
11	1	360371	THREAD SEAL
12	1	360353	JAM NUT 3/8 NC
13	4	360465	THREAD SEAL
14	2	360455	WASHER FLAT 1/4 ALUM
15	1	360359	GASKET
16	1	360364	THRUST PLATE

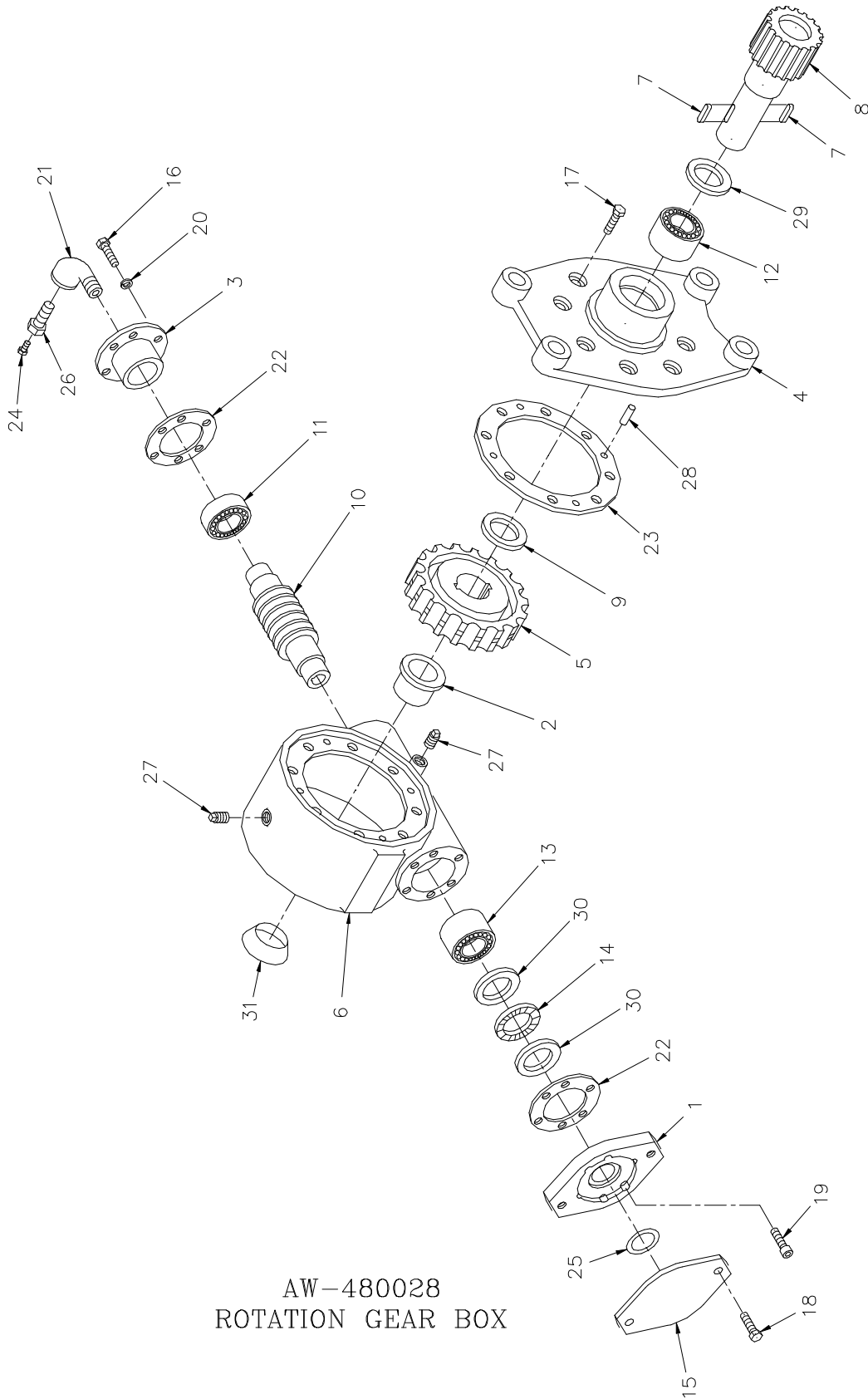

AW-480028  
 ROTATION GEAR BOX

AW-480028  
 ROTATION GEAR BOX

AW-480028  
ROTATION GEAR BOX

ITEM	QTY.	PART NO.	DESCRIPTION
1	1	480240	ADAPTER
2	1	480241	BUSHING
3	1	480242	CAP, BEARING
4	1	480243	COVER
5	1	480244	GEAR, R.H.
6	1	480237	HOUSING, GEAR
7	2	480246	KEY
8	1	480247	SHAFT, OUTPUT
9	1	480248	WASHER, THRUST
10	1	480249	WORM, R.H.
11	1	480251	BEARING, BALL
12	1	480252	BEARING, NEEDLE
13	1	480253	BEARING, NEEDLE
14	1	480254	BEARING, THRUST
15	1	480255	COVER
16	6	007400	CAPSCREW, 5/16-18NC X 1" LG. HX. HD.
17	8	480238	CAPSCREW, 5/16-18NC X 1 1/4 LG. HX. NYLOC HVY PATCH
18	2	011508	CAPSCREW, 1/2-13NC X 3/4 LG. HX. HD.
19	6	480256	CAPSCREW, 5/16-18NC X 1" LG. SOC. HD. LOC.-WEL
20	6	480258	LOCKWASHER, 5/16 MED. SECT. C.P.
21	1	480259	ELBOW, 90°
22	2	480260	GASKET
23	1	480250	GASKET
24	1	480262	FITTING, RELIEF
25	1	480239	O-RING
26	1	480263	REDUCER
27	2	480264	PLUG, PIPE
28	4	480265	PIN, DOWEL
29	1	480266	SEAL, OIL
30	2	480268	WASHER, THRUST
31	1	480269	PLUG, EXPANSION

# HOIST ACTUATOR

P/N 480075 - MODEL 6006H

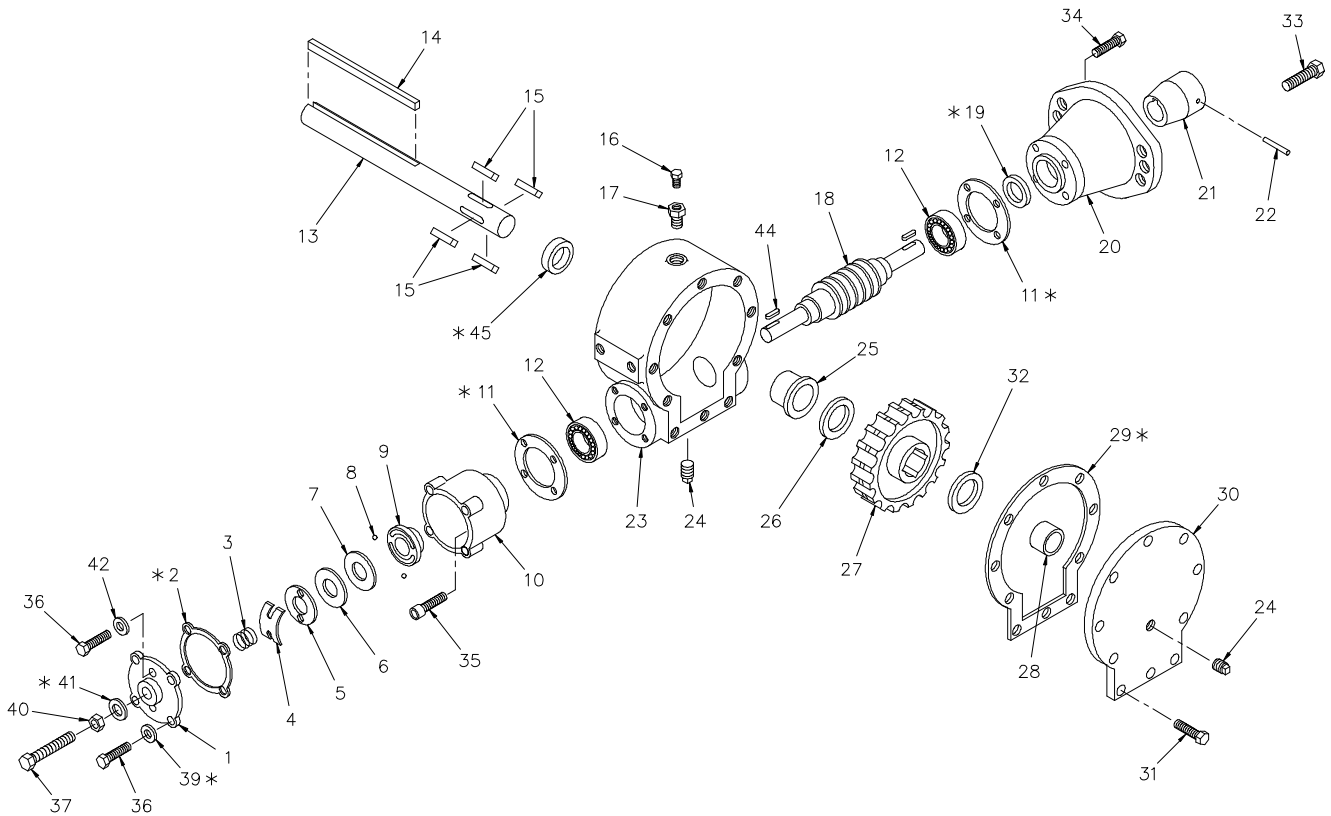

# *HOIST ACTUATOR*

*P/N 480075 - MODEL 6006H*

<u>ITEM</u>	<u>QTY</u>	<u>P/N</u>	<u>DESCRIPTION</u>
1	1	360450	WORM BRAKE COVER
*2	1	360359	GASKET
3	1	360368	SPRING
4	1	360367	FLAT SPRING
5	1	360342	RETAINER PLATE
6	1	360364	THRUST PLATE
7	1	360331	CAM PLATE
8	2	360345	BRAKE BALL
9	1	360339	BRAKE HUB
10	1	360336	BRAKE HOUSING
*11	2	360358	GASKET
12	2	360346	BEARING
13	1	480078	OUTPUT SHAFT
14	1	480094	KEY 3/8 SQ
15	4	360464	BARTH KEY
16	1	360360	RELIEF FITTING
17	1	360361	REDUCER
18	1	360344	RIGHT HAND WORM
*19	1	360365	OIL SEAL
20	1	360330	ADAPTER
21	1	360332	COUPLING
22	1	360363	SPIROL PIN
23	1	360461	GEAR HOUSING
24	2	360362	PIPE PLUG
25	1	360348	BUSHING
26	1	360369	THRUST WASHER
27	1	360460	RIGHT HAND GEAR
28	1	360462	BUSHING
*29	1	360459	GASKET
30	1	360458	COVER
31	10	360350	HEX HD CAPSCREW 1/4 NC x 3/4 GR5
32	1	360466	THRUST WASHER
33	2	010202	HEX HD CAPSCREW 1/2 NC x 1
34	4	360352	SOC HD CAPSCREW 1/4 NC x 1 3/4 GR5

# ***HOIST ACTUATOR***

***P/N 480075 - MODEL 6006H***

<b><u>ITEM</u></b>	<b><u>QTY</u></b>	<b><u>P/N</u></b>	<b><u>DESCRIPTION</u></b>
35	4	360463	SOC HD CAPSCREW 1/4 NC x 7/8
36	6	360453	HEX HD w/ NYLOCK CAPSCREW 1/4 NC x 1 GR5
37	1	360456	HEX HD CAPSCREW 1/8 NC x 1 1/2 GR5
38	-	-	-
*39	4	360465	THREAD SEAL
40	1	360353	HEX JAM NUT 3/8 NC
*41	1	360371	THREAD SEAL
42	2	360455	FLAT ALUMINUM WASHER 1/4
43	-	-	-
44	2	360341	KEY
*45	1	360366	OIL SEAL
46	1	480306	SEAL AND GASKET KIT

**NOTE: ITEMS MARKED WITH AN ASTERISK (\*) ARE INCLUDED IN SEAL & GASKET KIT P/N 480306 (ITEM 46).**

# IN-COMPARTMENT (IC) PENDANT INSTALLATION

## 6006 SERIES

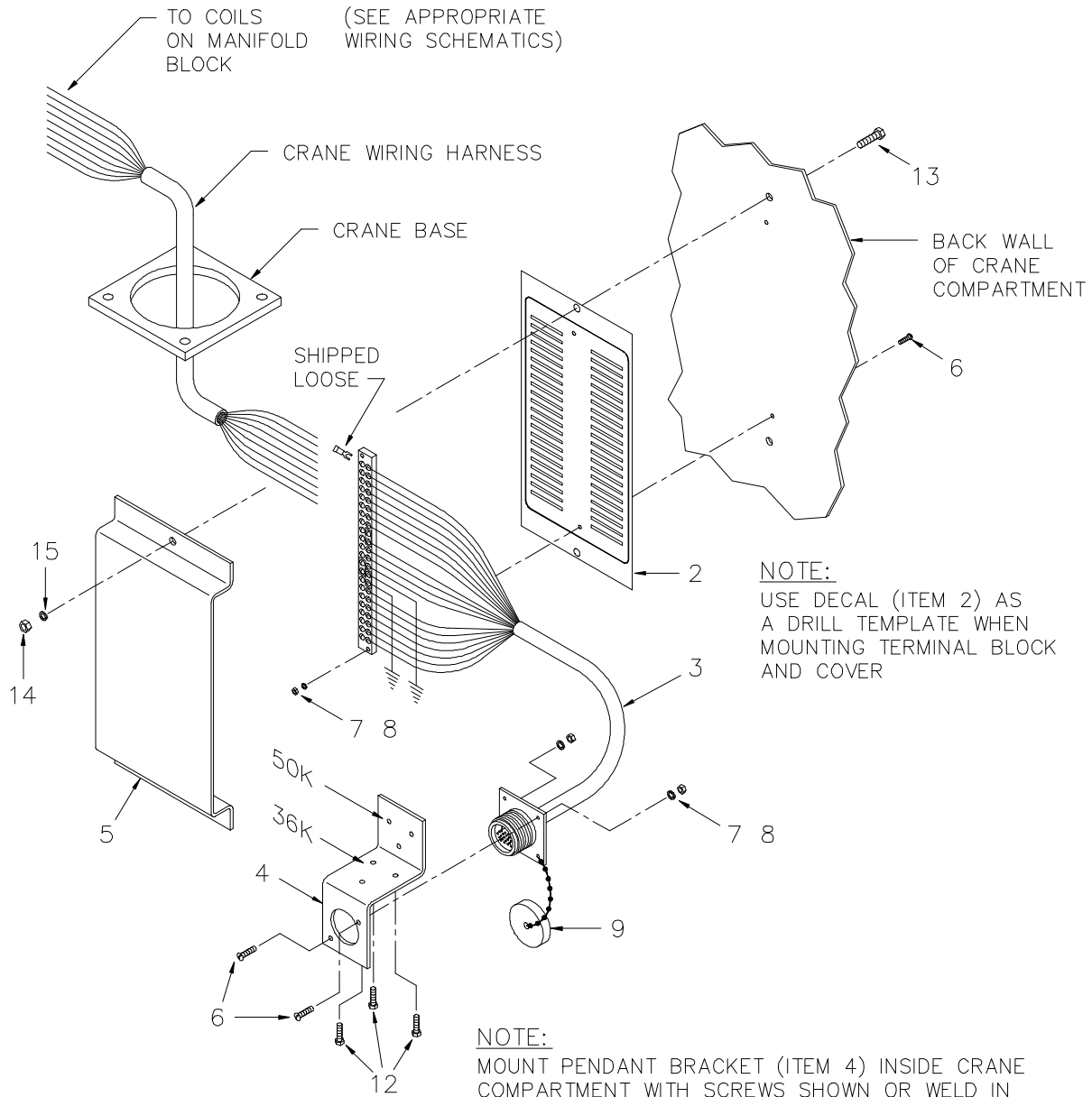



# ***IN-COMPARTMENT (IC) PENDANT INSTALLATION***

## ***6006 SERIES***

<b><u>ITEM</u></b>	<b><u>QTY</u></b>	<b><u>P/N</u></b>	<b><u>DESCRIPTION</u></b>
1	-	-	-
2	1	480490	22 STATION TERMINAL BLOCK DECAL
3	1	480491-080	22 STATION / 19 PIN SOCKET HARNESS (BAYONET)
4	1	480626	PENDANT BRACKET
5	1	480493	22 STATION TERMINAL BLOCK COVER
6	4	000404	ROUND HEAD SCREW #6-32 NC x 5/8
7	4	015400	HEX NUT #6-32 NC
8	4	019600	SPLIT LOCK WASHER #6
9	1	366097	19 PIN RECEPTACLE CAP
10	6	750738	WIRE TIE STICK ON RETAINER
11	6	634401	WIRE TIE x 7"
12	3	330038	CAPSCREW #10-24 NC x 3/4 SELF TAPPING
13	2	005500	CAPSCREW 1/4-20 NC x 3/4 G5
14	2	015900	HEX NUT 1/4-20 NC
15	2	020200	SPLIT LOCK WASHER 1/4

# FM REMOTE INSTALLATION

## 6006H

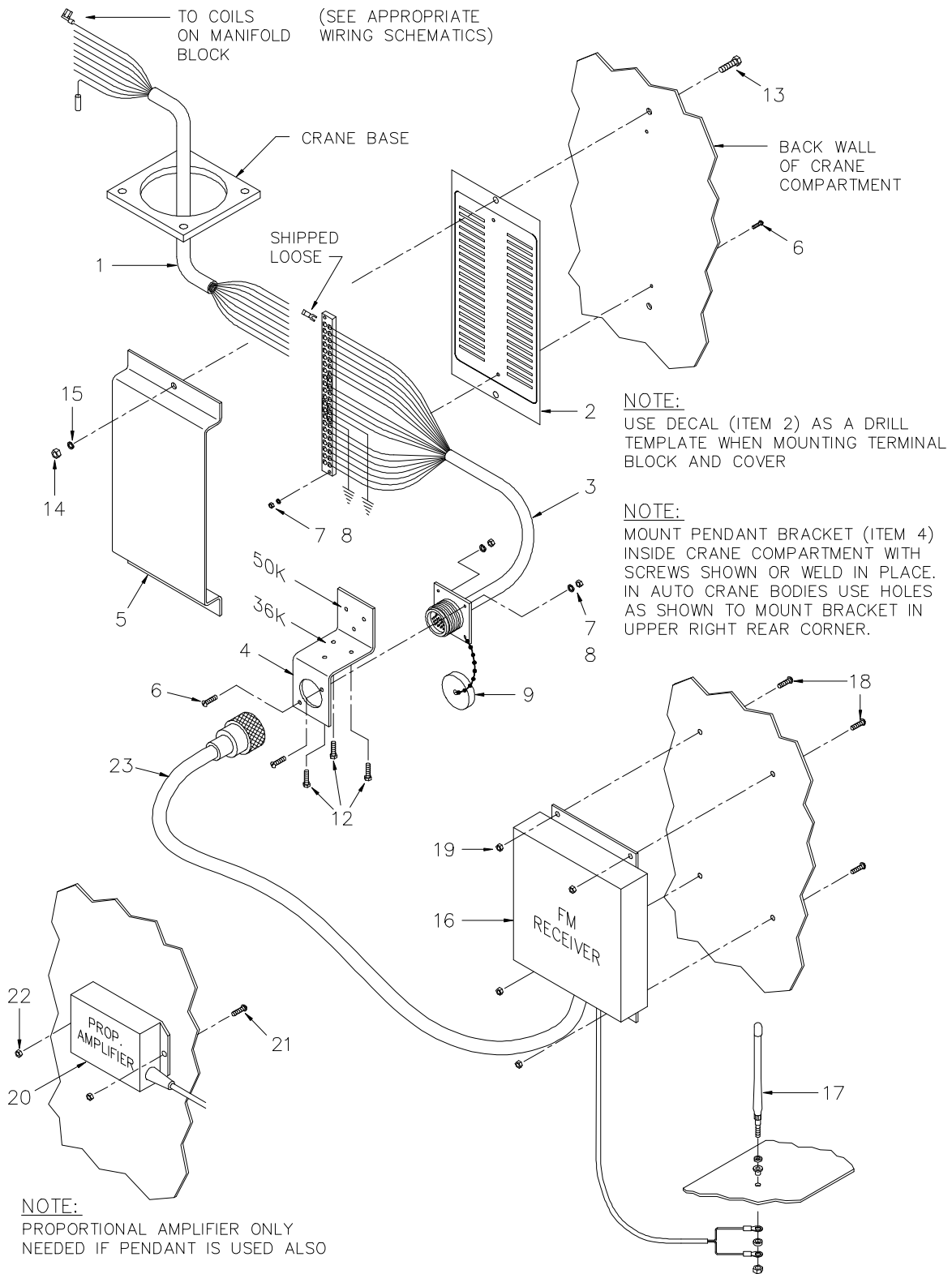

# ***FM REMOTE INSTALLATION***

## ***6006H***

<b><u>ITEM</u></b>	<b><u>QTY</u></b>	<b><u>P/N</u></b>	<b><u>DESCRIPTION</u></b>
1	1	480492	CRANE PIGTAIL HARNESS
2	1	480490	22 STATION TERMINAL BLOCK DECAL
3	1	480491-080	22 STATION / 19 PIN SOCKET HARNESS (BAYONET)
4	1	480626	PENDANT BRACKET
5	1	480493	22 STATION TERMINAL BLOCK COVER
6	4	000404	RD HD #6-32 NC x 5/8
7	4	015400	HEX NUT #6-32 NC
8	4	019600	WASHER SP LK #6
9	1	366097	19 PIN RECEPTACLE CAP
10	6	750738	WIRE TIE STICK ON RETAINER
11	6	634401	WIRE TIE x 7"
12	3	330038	HEX HD SCREW #10-24 NC x 3/4 SELF TAPPING
13	2	005500	HEX HD SCREW 1/4-20 NC x 3/4 G5
14	2	015900	HEX NUT 1/4-20 NC
15	2	020200	WASHER SP LK 1/4
16	1	480629	FM REMOTE TRANSMITTER / RECEIVER ASSEMBLY
17	1	(SEE NOTE)	ANTENNA (STD)
18	4	002607	RD HD SCREW #10-24 NC x 3/4
19	4	015801	HEX LOCK NUT #10-24 NF x 3/4
20	1	480537	PROPORTIONAL AMPLIFIER
21	2	002200	RD HD SCREW #10-32 NF x 3/4
22	2	015800	HEX LOCK NUT #10-32 NF x 3/4
23	1	680048	CONTROL CABLE

**NOTE:** Standard antenna comes with transmitter / receiver assembly; - antenna with magnetic base (P/N 480608) can be ordered as an extra cost option.

# ***ELECTRICAL ASSEMBLY***

## ***P/N 366200***

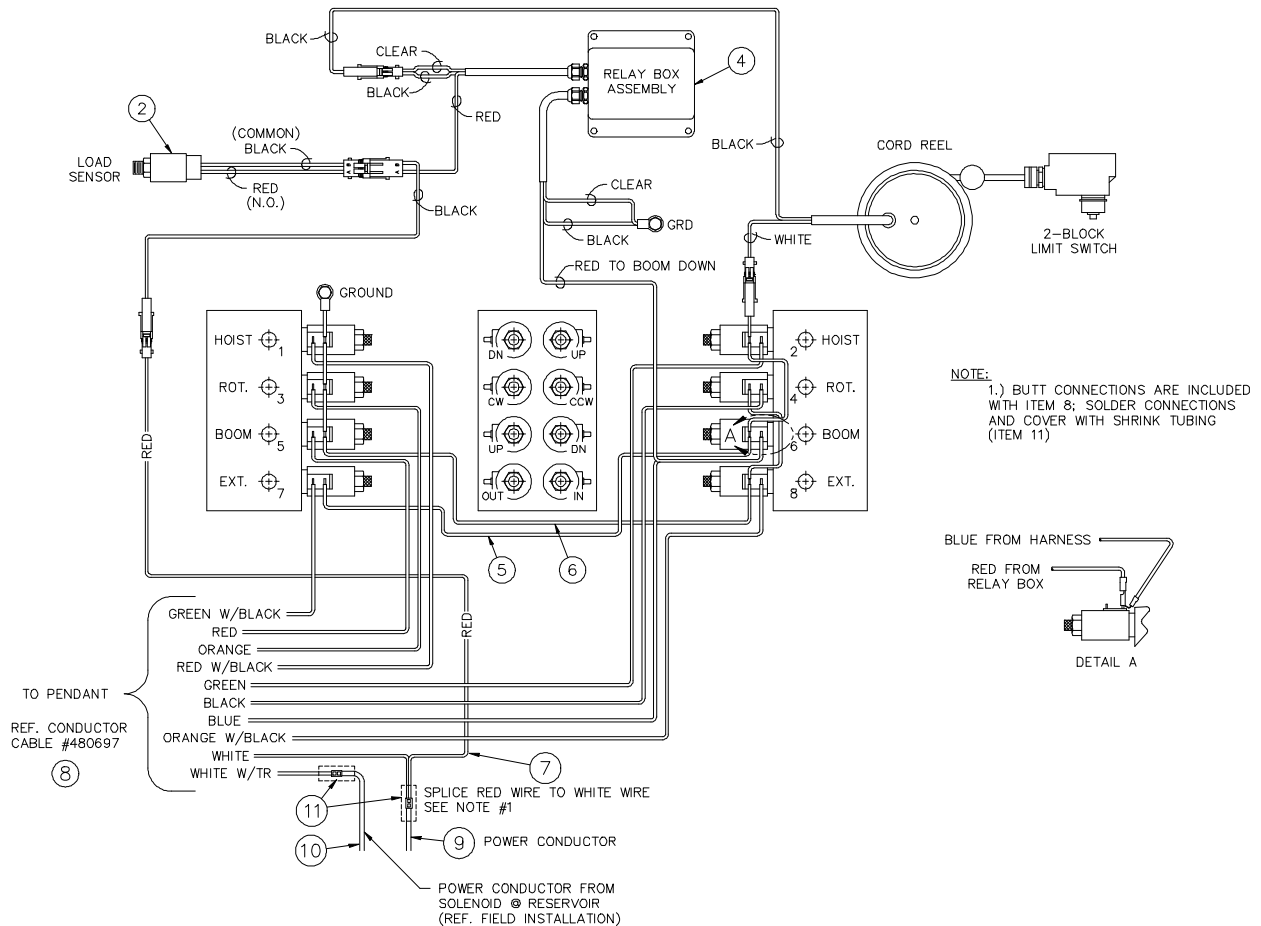

<b>ITEM</b>	<b>QTY</b>	<b>P/N</b>	<b>DESCRIPTION</b>
2	1	REFERENCE	LOAD SENSOR
4	1	REFERENCE	RELAY BOX ASSEMBLY
5	1	REFERENCE	CONDUCTOR BOX ASSEMBLY
6	1	REFERENCE	CONDUCTOR BOX ASSEMBLY
7	1	REFERENCE	CONDUCTOR BOX ASSEMBLY
8	1	REFERENCE	CONDUCTOR CABLE
9	1	REFERENCE	POWER CONDUCTOR
10	1	REFERENCE	CONDUCTOR
11	2	REFERENCE	SHRINK TUBING ¼ IN. X 3 IN.

# CRANE WIRING w/ 4 & 8 FUNCTION PENDANTS

## PROPORTIONAL (-200, -400) - 6006H

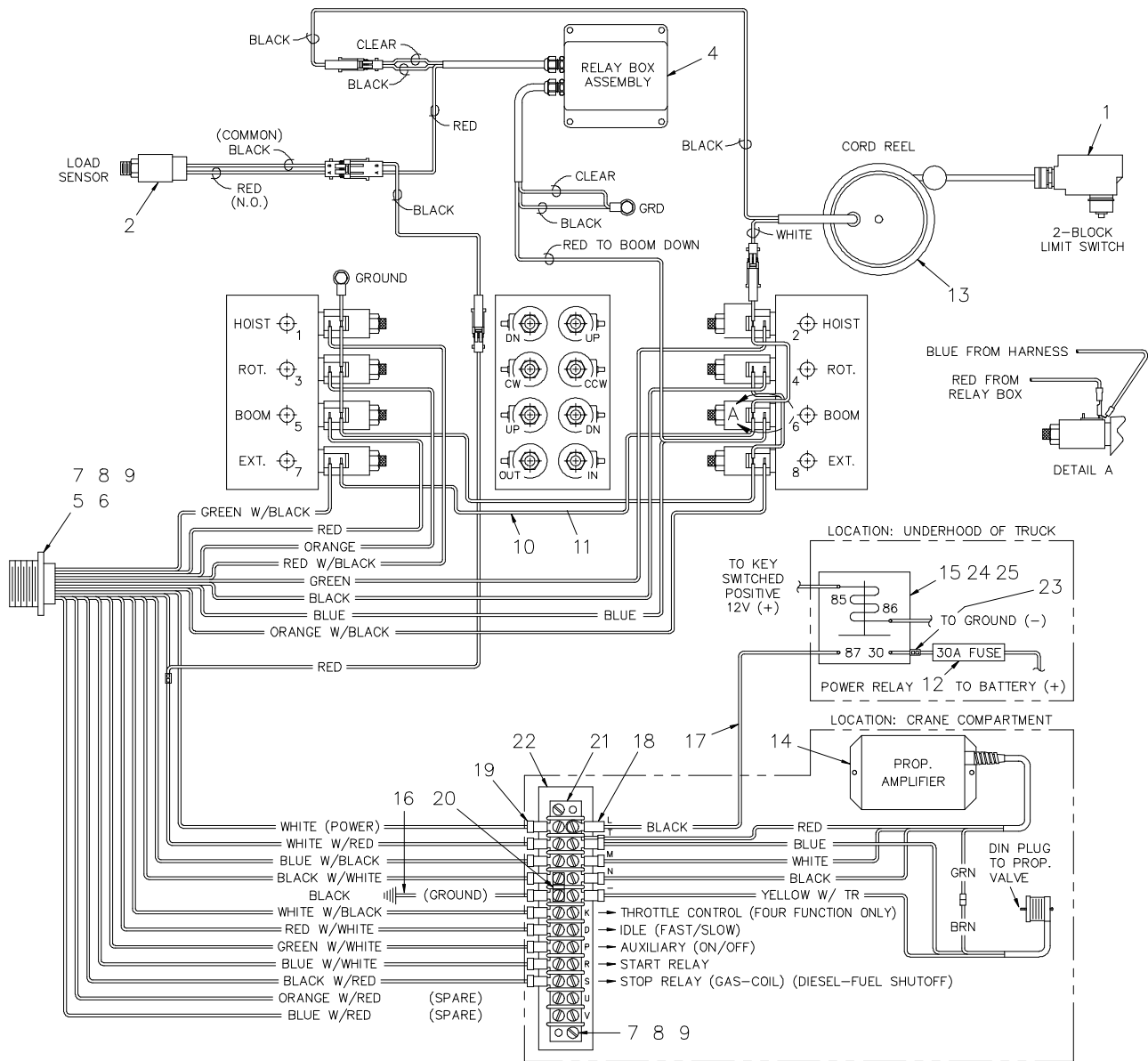

**CRANE WIRING w/ 4 & 8 FUNCTION PENDANTS**  
**PROPORTIONAL (-200, -400) - 6006H**

<u>ITEM</u>	<u>QTY</u>	<u>P/N</u>	<u>DESCRIPTION</u>
1	1	646900	SWITCH
2	1	320543	LOAD SENSOR ASSEMBLY
3	-	-	-
4	1	366999	RELAY BOX ASSEMBLY
5	1	680044	RECEPTACLE ASSEMBLY
6	1	366097	PENDANT RECEPTACLE CAP
7	4	000404	RD HD SCREW #6-32 x 5/8
8	4	019600	WASHER SP LK #6
9	4	015400	HX NUT #6-32
10	1	480384	CONDUCTOR ASSEMBLY
11	1	360549	CONDUCTOR ASSEMBLY
12	1	750167	30 AMP IN-LINE FUSE
13	1	366973-001	CORD REEL ASSEMBLY
14	1	480522	PROPORTIONAL AMPLIFIER ASSEMBLY
15	1	320355	POWER RELAY
16	1	480549	CONDUCTOR 16GA ST BLACK
17	1	800657-009	POWER CONDUCTOR
18	1	001002	RING TERMINAL
19	15	480495	FLANGED SPADE 16-14 WRE TERMINAL
20	1	636600	JUMPER
21	1	635200	TERMINAL BLOCK
22	1	360610	DECAL TERMINAL I.D.
23	2	001102	WR 2RC-10 TERMINAL
24	1	320363	RELAY PLUG
25	5	320357	SPD LOCKING NON-INS CONNECTOR

# CRANE WIRING w/ 4 & 8 FUNCTION PENDANTS

## LESS PROPORTIONAL (-100, -300) - 6006H

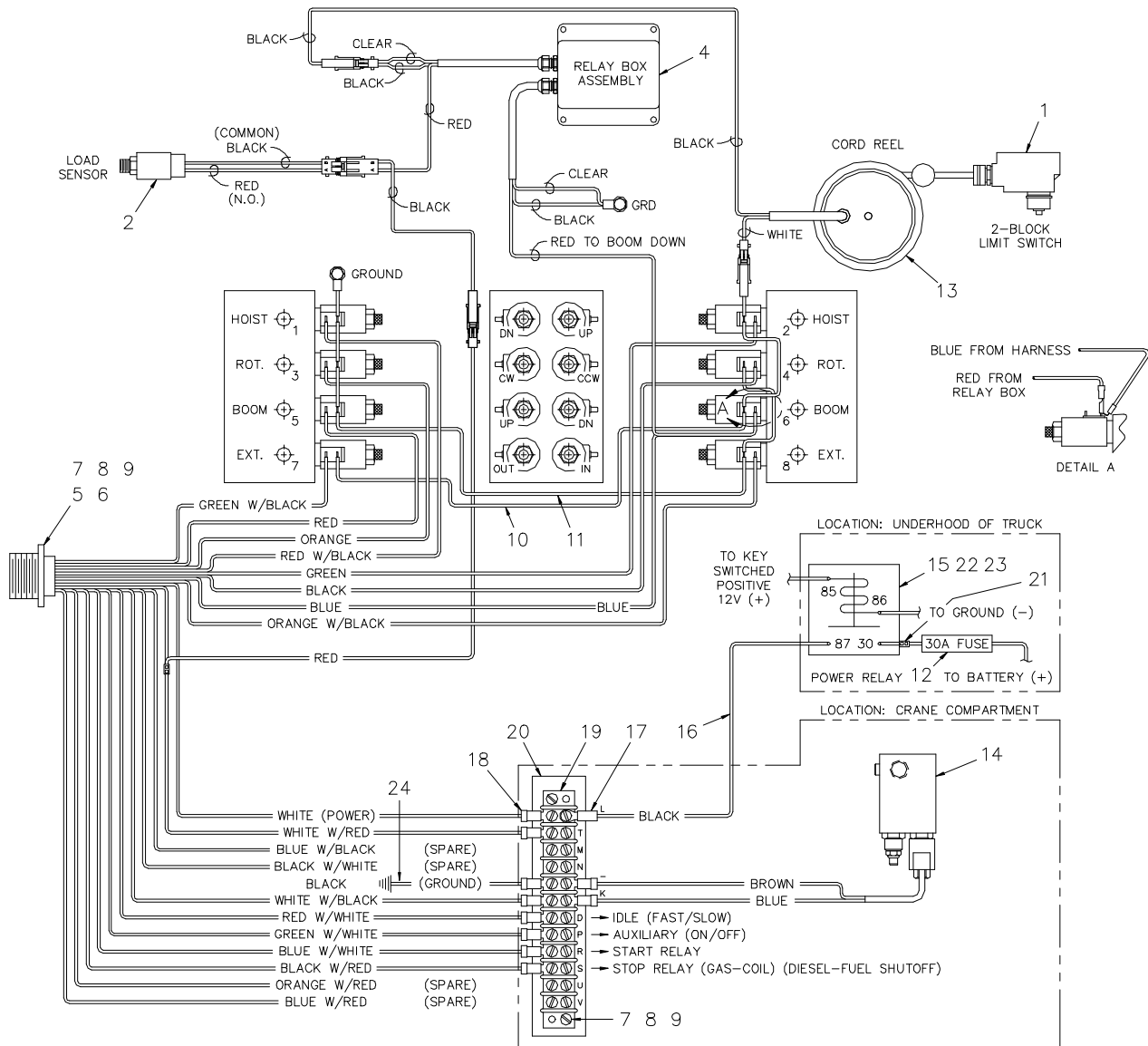

**CRANE WIRING w/ 4 & 8 FUNCTION PENDANTS**  
**LESS PROPORTIONAL (-100, -300) - 6006H**

<u>ITEM</u>	<u>QTY</u>	<u>P/N</u>	<u>DESCRIPTION</u>
1	1	646900	SWITCH
2	1	320543	LOAD SENSOR ASSEMBLY
3	-	-	-
4	1	366999	RELAY BOX ASSEMBLY
5	1	680044	RECEPTACLE ASSEMBLY
6	1	366097	PENDANT RECEPTACLE CAP
7	4	000404	RD HD SCREW #6-32 x 5/8
8	4	019600	WASHER SP LK #6
9	4	015400	HX NUT #6-32
10	1	480384	CONDUCTOR ASSEMBLY
11	1	360549	CONDUCTOR ASSEMBLY
12	1	750167	30 AMP IN-LINE FUSE
13	1	366973-001	CORD REEL ASSEMBLY
14	1	366212	RELIEF VALVE ASSEMBLY w/ SOLENOID
15	1	320355	POWER RELAY
16	1	800657-009	POWER CONDUCTOR
17	1	001002	RING TERMINAL
18	10	480495	FLANGED SPADE 16-14 WRE TERMINAL
19	1	635200	TERMINAL BLOCK
20	1	360610	DECAL TERMINAL I.D.
21	1	001102	WR 2RC-10 TERMINAL
22	1	320363	RELAY PLUG
23	5	320357	SPD LOCKING NON-INS CONNECTOR
24	1	480549	CONDUCTOR 16GA ST BLACK



# CRANE WIRING w/ 4 & 8 FUNCTION PENDANTS

PROP. IC (-210, -410, -411, -412) - 6006H

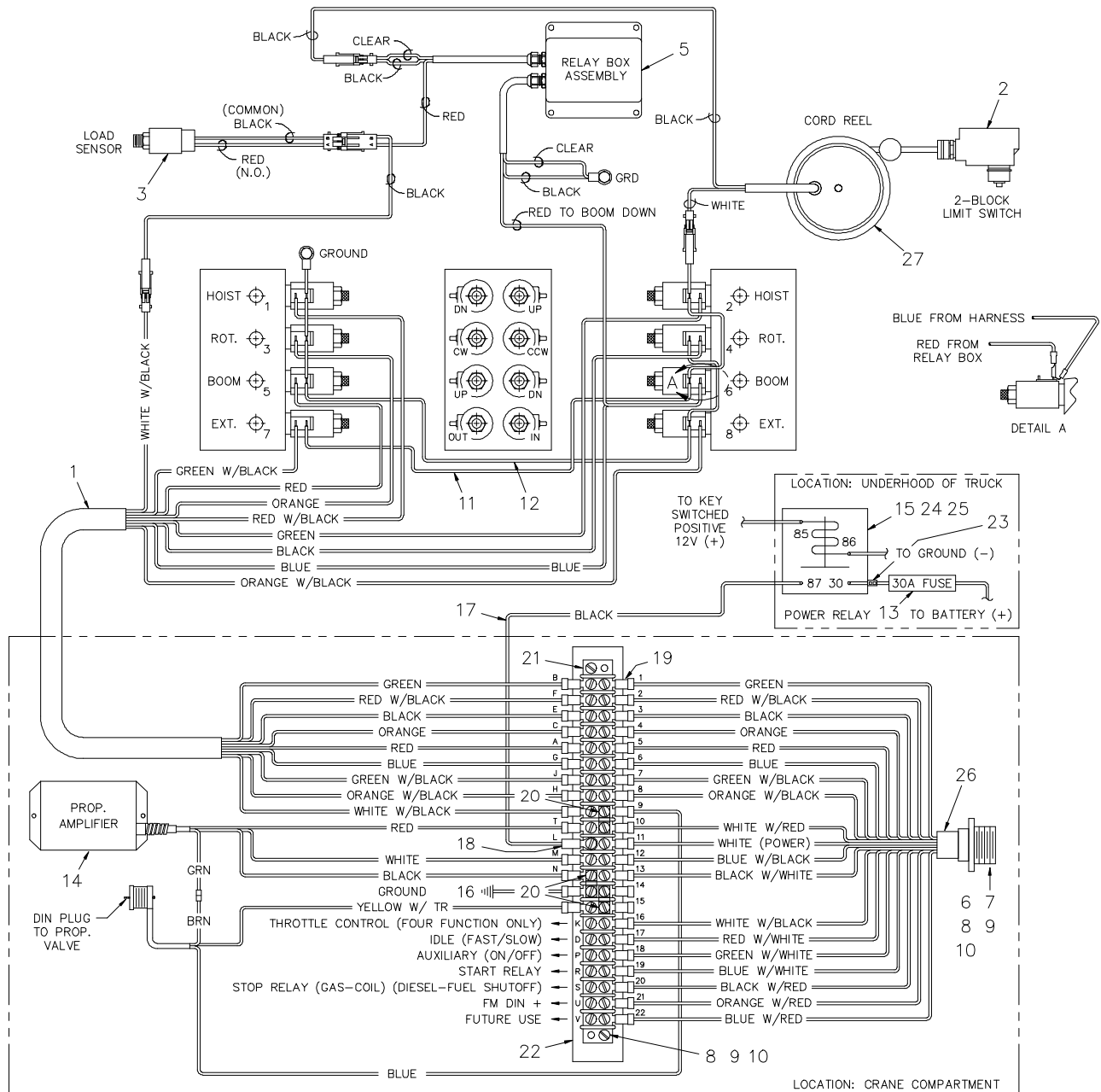

# **CRANE WIRING w/ 4 & 8 FUNCTION PENDANTS**

## **PROP. IC (-210, -410, -411, -412) - 6006H**

<b>ITEM</b>	<b>QTY</b>	<b>P/N</b>	<b>DESCRIPTION</b>
1	1	480386	CRANE PIGTAIL HARNESS
2	1	646900	SWITCH
3	1	320543	LOAD SENSOR ASSEMBLY
4	-	-	-
5	1	366999	RELAY BOX ASSEMBLY
6	1	480626	PENDANT RECEPTACLE BRACKET
7	1	366097	PENDANT RECEPTACLE CAP
8	4	000404	RD HD SCREW #6-32 x 5/8
9	4	019600	WASHER SP LK #6
10	4	015400	HEX NUT #6-32
11	1	480384	CONDUCTOR ASSEMBLY
12	1	360549	CONDUCTOR ASSEMBLY POWER EXT
13	1	750167	IN-LINE 30 AMP FUSE
14	1	480522	PROP AMPLIFIER ASSEMBLY
15	1	320355	POWER RELAY
16	1	480549	CONDUCTOR 16GA BLACK
17	1	800657-009	POWER CONDUCTOR
18	1	001002	RING TERMINAL
19	36	480495	FLANGED SPADE 16-14 WIRE TERMINAL
20	3	636600	JUMPER
21	1	480494	TERMINAL BLOCK 22 STA
22	1	480490	DECAL 2 STA TERMINAL BLOCK
23	1	001102	WR 2RC-10 TERMINAL
24	1	320363	RELAY PLUG
25	5	320357	SPD LOCKING NON-INS CONNECTOR
*26	1	480491-080	HARNESS ASSEMBLY
27	1	366973-001	CORD REEL ASSEMBLY

\*NOTE: Item 26 includes items 19, 20, & 21.

# CRANE WIRING w/ 4 & 8 FUNCTION PENDANTS

## LESS PROP. IC (-110, -310) - 6006H

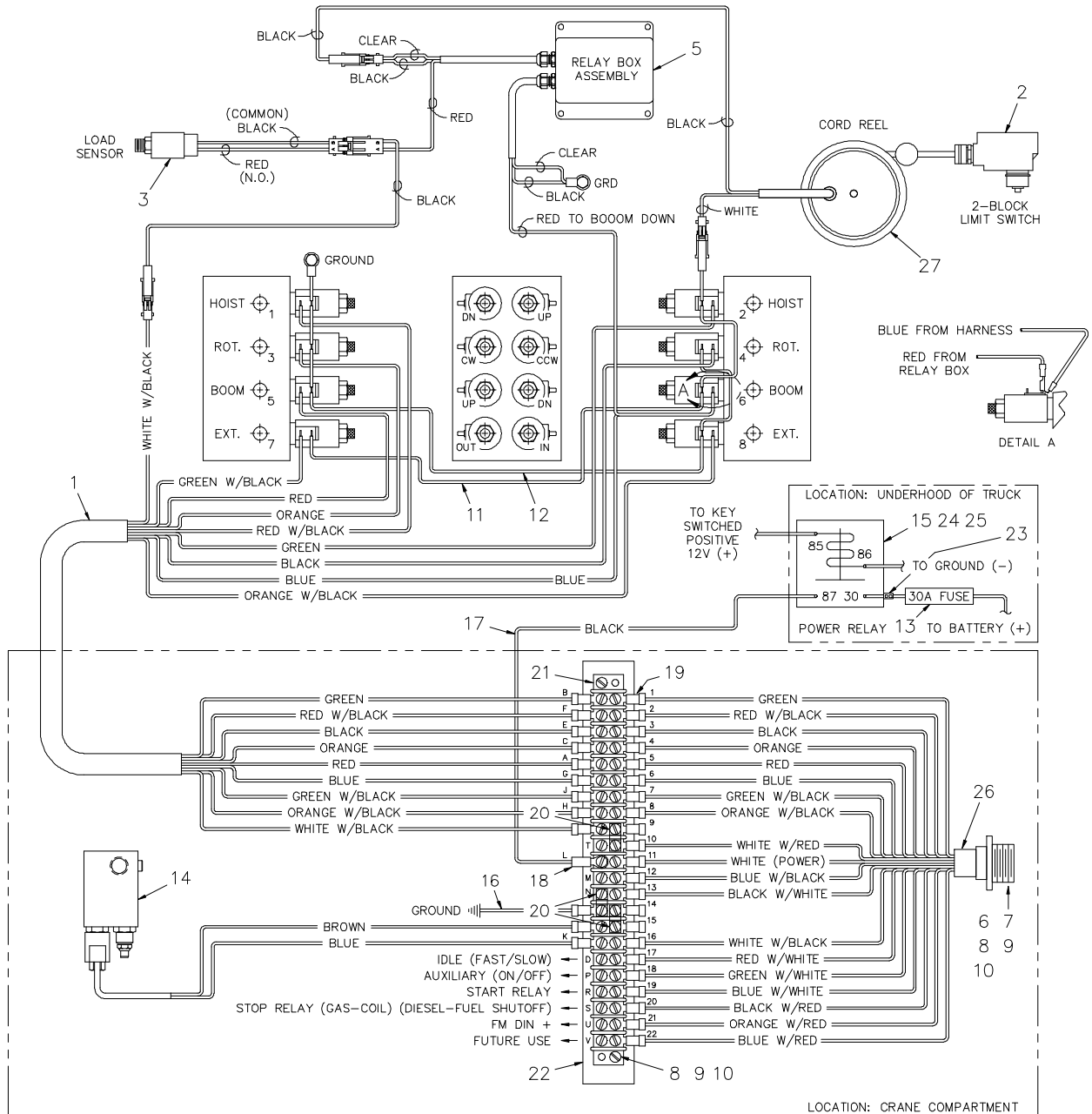

**CRANE WIRING w/ 4 & 8 FUNCTION PENDANTS**  
**LESS PROP. IC (-110, -310) - 6006H**

<u>ITEM</u>	<u>QTY</u>	<u>P/N</u>	<u>DESCRIPTION</u>
1	1	480386	CRANE PIGTAIL HARNESS
2	1	646900	SWITCH
3	1	320543	LOAD SENSOR ASSEMBLY
4	-	-	-
5	1	366999	RELAY BOX ASSEMBLY
6	1	480626	PENDANT RECEPTACLE BRACKET
7	1	366097	PENDANT RECEPTACLE CAP
8	4	000404	RD HD SCREW #6-32 x 5/8
9	4	019600	WASHER SP LK #6
10	4	015400	HEX NUT #6-32
11	1	480384	CONDUCTOR ASSEMBLY
12	1	360549	CONDUCTOR ASSEMBLY POWER EXT
13	1	750167	IN-LINE 30 AMP FUSE
14	1	366212	RELIEF VALVE ASSEMBLY w/ SOLENOID
15	1	320355	POWER RELAY
16	1	480549	CONDUCTOR 16GA BLACK
17	1	800657-009	POWER CONDUCTOR
18	1	001002	RING TERMINAL
19	34	480495	FLANGED SPADE 16-14 WIRE TERMINAL
20	3	636600	JUMPER
21	1	480494	TERMINAL BLOCK 22 STA
22	1	480490	DECAL 2 STA TERMINAL BLOCK
23	1	001102	WR 2RC-10 TERMINAL
24	1	320363	RELAY PLUG
25	5	320357	SPD LOCKING NON-INS CONNECTOR
*26	1	480491-080	HARNESS ASSEMBLY
27	1	366973-001	CORD REEL ASSEMBLY

\*NOTE: Item 26 includes items 19, 20, & 21.

# CRANE WIRING w/ 8 FUNCTION PENDANT

## PROP. IC & 12 FUNCTION FM REMOTE (-510,-530)

### 6006H

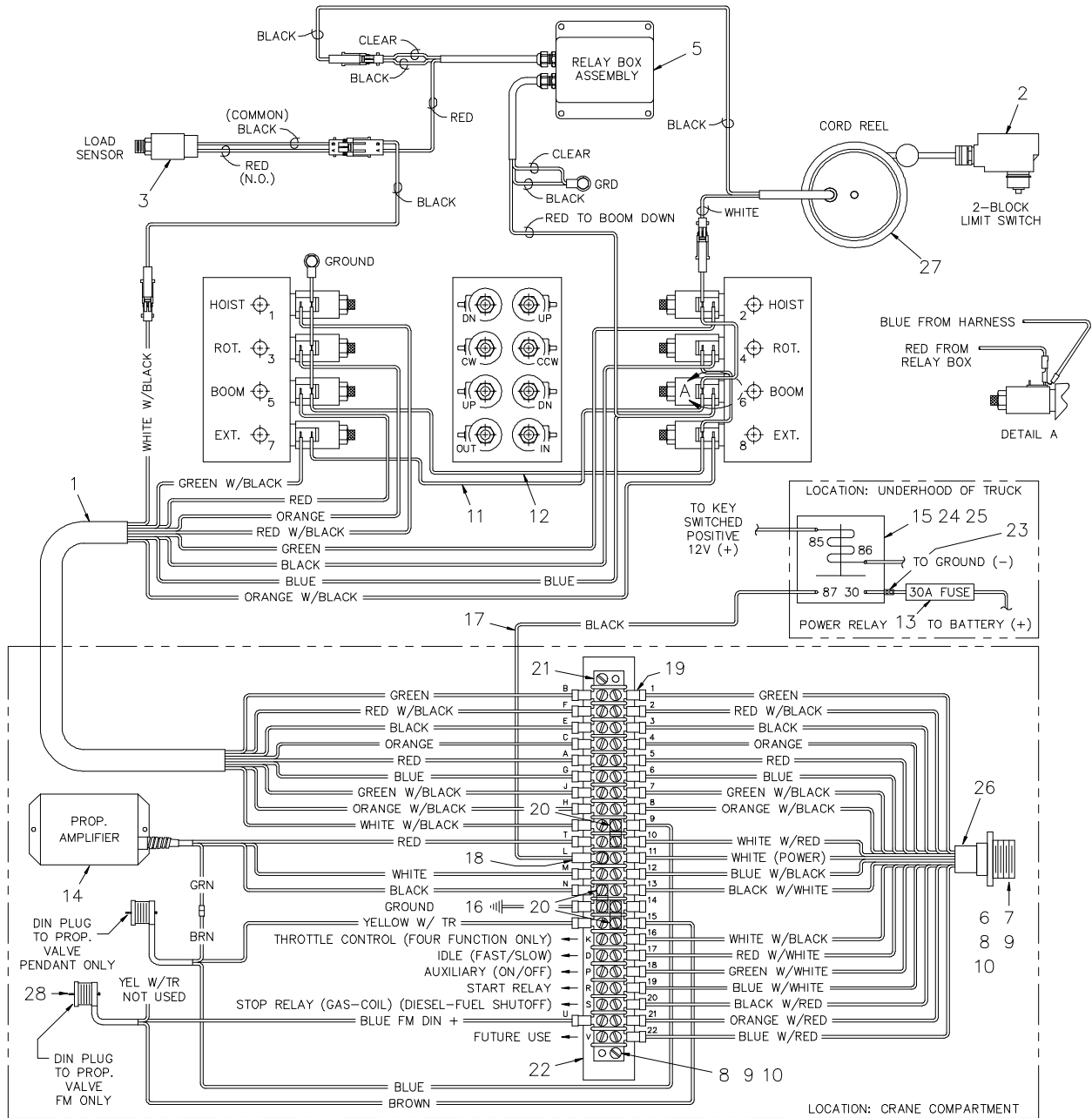

**CRANE WIRING w/ 8 FUNCTION PENDANT  
PROP. IC & 12 FUNCTION FM REMOTE (-510,-530)  
6006H**

<u>ITEM</u>	<u>QTY</u>	<u>P/N</u>	<u>DESCRIPTION</u>
1	1	480386	CRANE PIGTAIL HARNESS
2	1	646900	SWITCH
3	1	320543	LOAD SENSOR ASSEMBLY
4	-	-	-
5	1	366999	RELAY BOX ASSEMBLY
6	1	480626	PENDANT RECEPTACLE BRACKET
7	1	366097	PENDANT RECEPTACLE CAP
8	4	000404	RD HD SCREW #6-32 x 5/8
9	4	019600	WASHER SP LK #6
10	4	015400	HEX NUT #6-32
11	1	480384	CONDUCTOR ASSEMBLY
12	1	360549	CONDUCTOR ASSEMBLY POWER EXT
13	1	750167	IN-LINE 30 AMP FUSE
14	1	480522	PROP AMPLIFIER ASSEMBLY
15	1	320355	POWER RELAY
16	1	480549	CONDUCTOR 16GA BLACK
17	1	800657-009	POWER CONDUCTOR
18	1	001002	RING TERMINAL
19	34	480495	FLANGED SPADE 16-14 WIRE TERMINAL
20	3	636600	JUMPER
21	1	480494	TERMINAL BLOCK 22 STA
22	1	480490	DECAL 2 STA TERMINAL BLOCK
23	1	001102	WR 2RC-10 TERMINAL
24	1	320363	RELAY PLUG
25	5	320357	SPD LOCKING NON-INS CONNECTOR
*26	1	480491-080	HARNESS ASSEMBLY
27	1	366973-001	CORD REEL ASSEMBLY
28	1	480613	DIN CONNECTOR w/ CORD

\*NOTE: Item 26 includes items 19, 20, & 21.

# CRANE WIRING w/ FM REMOTE, PROPORTIONAL (-500,-520)

## 6006H

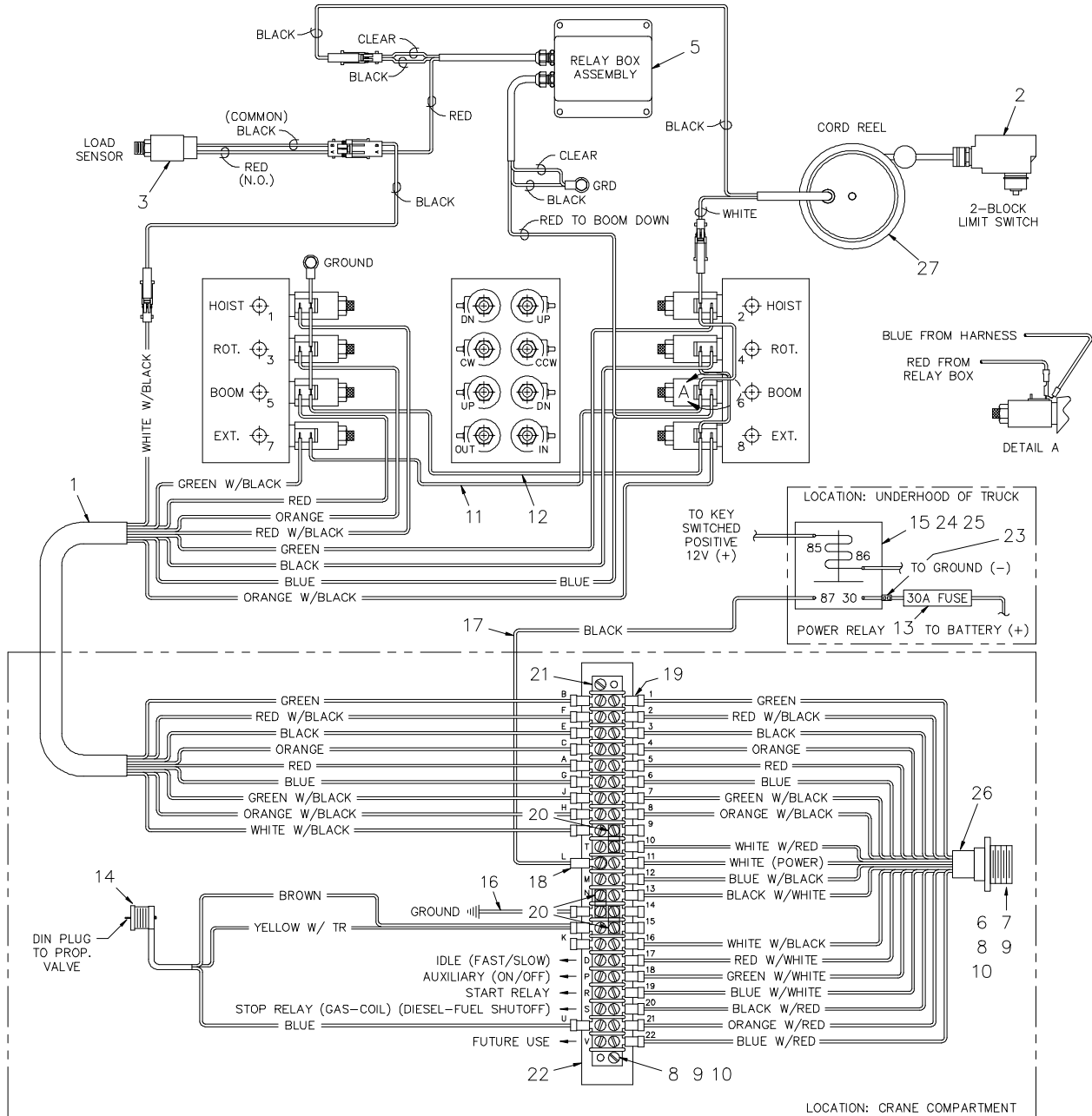

**CRANE WIRING w/ FM REMOTE, PROPORTIONAL  
(-500,-520)**

**6006H**

<u>ITEM</u>	<u>QTY</u>	<u>P/N</u>	<u>DESCRIPTION</u>
1	1	480386	CRANE PIGTAIL HARNESS
2	1	646900	SWITCH
3	1	320543	LOAD SENSOR ASSEMBLY
4	-	-	-
5	1	366999	RELAY BOX ASSEMBLY
6	1	480626	PENDANT RECEPTACLE BRACKET
7	1	366097	PENDANT RECEPTACLE CAP
8	4	000404	RD HD SCREW #6-32 x 5/8
9	4	019600	WASHER SP LK #6
10	4	015400	HEX NUT #6-32
11	1	480384	CONDUCTOR ASSEMBLY
12	1	360549	CONDUCTOR ASSEMBLY POWER EXT
13	1	750167	IN-LINE 30 AMP FUSE
14	1	480612	DIN PLUG ASSEMBLY
15	1	320355	POWER RELAY
16	1	480549	CONDUCTOR 16GA BLACK
17	1	800657-009	POWER CONDUCTOR
18	1	001002	RING TERMINAL
19	34	480495	FLANGED SPADE 16-14 WIRE TERMINAL
20	3	636600	JUMPER
21	1	480494	TERMINAL BLOCK 22 STA
22	1	480490	DECAL 2 STA TERMINAL BLOCK
23	1	001102	WR 2RC-10 TERMINAL
24	1	320363	RELAY PLUG
25	5	320357	SPD LOCKING NON-INS CONNECTOR
*26	1	480491-080	HARNESS ASSEMBLY
27	1	366973-001	CORD REEL ASSEMBLY

\*NOTE: Item 26 includes items 19, 20, & 21.



# PENDANT RECEPTACLE ASSEMBLY

P/N 680044 - 6006H

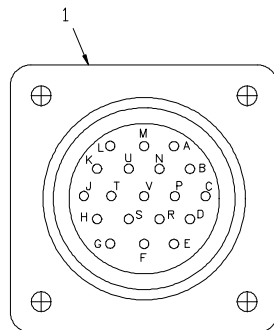
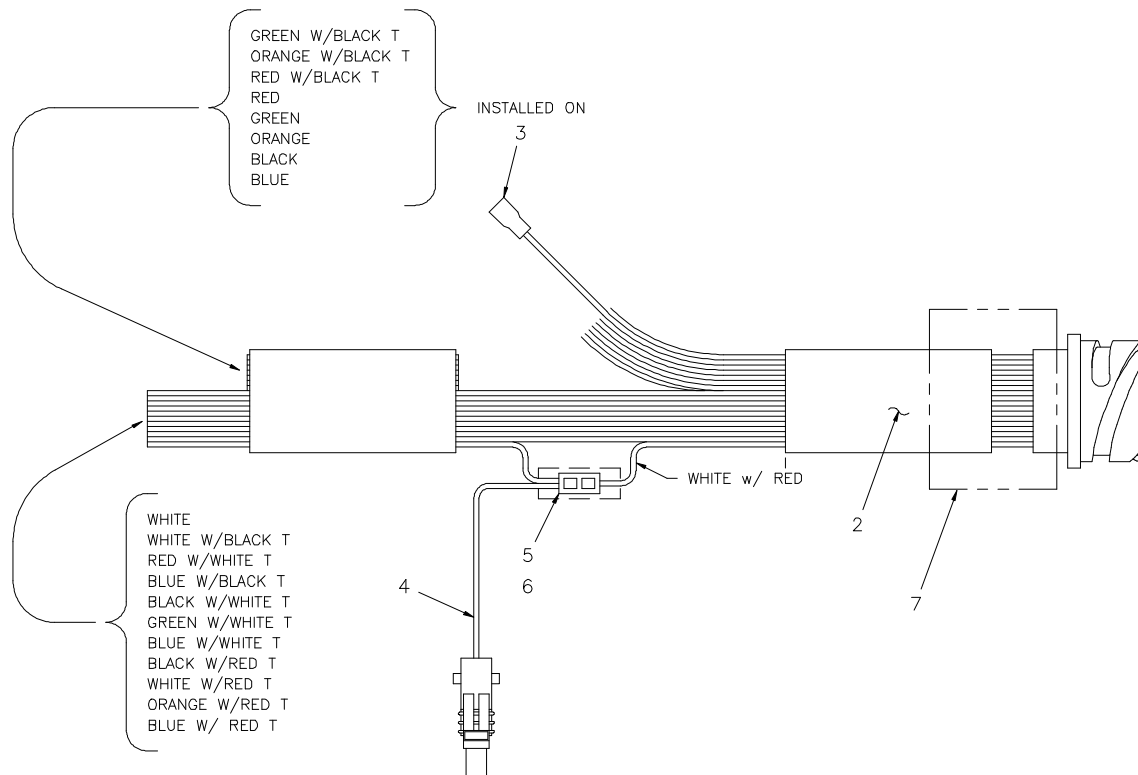

### WIRING GUIDE

A-RED	L-WHITE
B-GREEN	M-BLUE W/BLACK T
C-ORANGE	N-BLACK W/WHITE T
D-RED W/WHITE T	P-GREEN W/WHITE T
E-BLACK	R-BLUE W/WHITE T
F-RED W/BLACK T	S-BLACK W/RED T
G-BLUE	T-WHITE W/RED T
H-ORANGE W/BLACK T	U-ORANGE W/RED T
J-GREEN W/BLACK T	V-BLUE W/ RED T
K-WHITE W/BLACK T	

ITEM	QTY	P/N	DESCRIPTION
1	1	366095	19 PIN RECEPTACLE
2	1	480515	CABLE CLAMP
3	8'	480594	19 PIN CONDUCTOR CABLE
4	1	480385	CONDUCTOR ASSEMBLY
5	1	001105	BUTT CONNECTOR TERMINAL NON-INSS 10-12 GA
6	-	002012	RING TERMINAL #6 / 18-22 GA
7	4"	490243	HEAT SHRINK TUBING

# REMOVABLE 4 FUNCTION 19 PIN PENDANT ASSEMBLY

P/N 680083 - 6006H

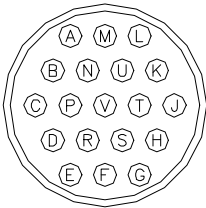
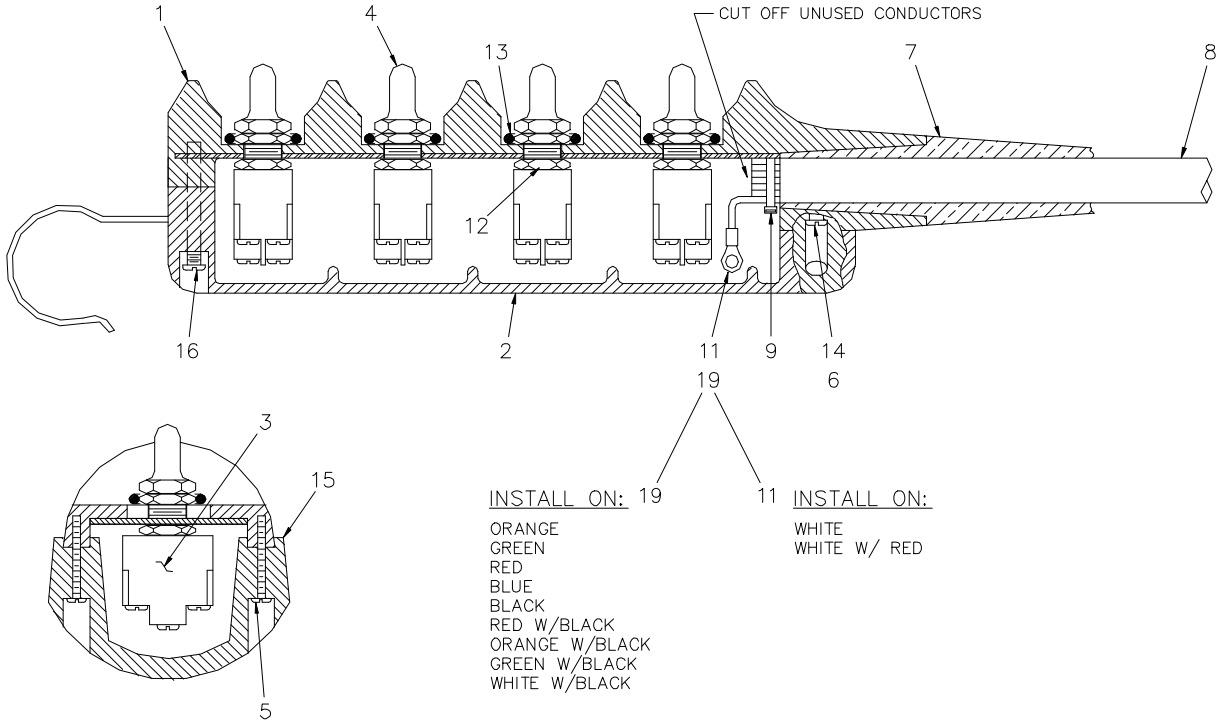

## WIRING GUIDE

- |                  |                 |
|------------------|-----------------|
| A-RED            | L-WHITE         |
| B-GREEN          | M-BLUE W/BLACK  |
| C-ORANGE         | N-BLACK W/WHITE |
| D-RED W/WHITE    | P-GREEN W/WHITE |
| E-BLACK          | R-BLUE W/WHITE  |
| F-RED W/BLACK    | S-BLACK W/RED   |
| G-BLUE           | T-WHITE W/RED   |
| H-ORANGE W/BLACK | U-ORANGE W/RED  |
| J-GREEN W/BLACK  | V-BLUE W/RED    |
| K-WHITE W/BLACK  |                 |

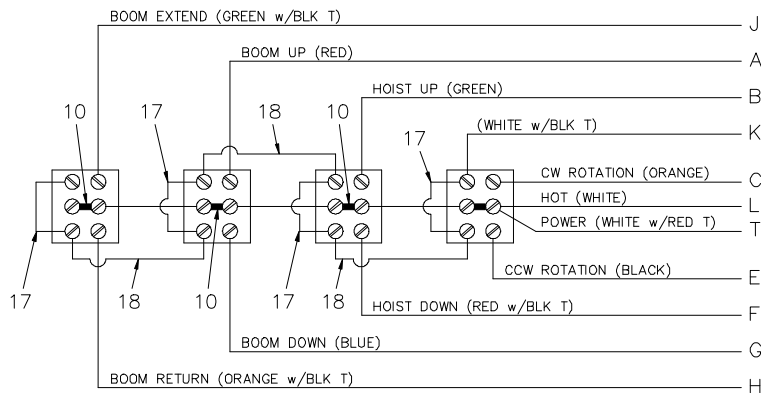
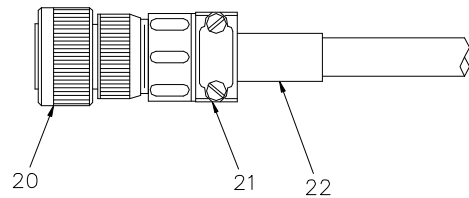

VIEW FROM BOTTOM

**REMOVABLE 4 FUNCTION 19 PIN PENDANT  
ASSEMBLY**

**P/N 680083 - 6006H**

<u>ITEM</u>	<u>QTY</u>	<u>P/N</u>	<u>DESCRIPTION</u>
1	1	631601	PENDANT HOUSING
2	1	631700	BOTTOM COVER
3	4	634200	TOGGLE SWITCH
4	4	640300	TOGGLE SWITCH BOOT
5	10	005001	ST SLT PAN HD SCREW #8 x 3/4
6	2	005101	ST SLT PAN HD SCREW #8 x 1 1/4
7	1	633801	CABLE ADAPTER
8	30'	480594	19 PIN CONDUCTOR CABLE
9	2	634401	TY-RAP CABLE TIE
10	4	536600	JUMPER
11	2	000101	RING TERMINAL #6 / 14-16 GA
12	4	675271	NUT
13	4	642100	O-RING
14	4	019700	SPLIT LOCK WASHER #8 PLATED
15	21"	800580	3/4 WIDE OKONITE RUBBER TAPE
16	1	004700	ST SLT PAN HD SCREW #8 x 1 1/2
17	4	622346	CONDUCTOR ASSEMBLY 2 1/8
18	3	622347	CONDUCTOR ASSEMBLY 3 1/8
19	9	002012	RING TERMINAL #6 / 18-22 GA
20	1	366098	19 PIN PLUG
21	1	480515	CABLE CLAMP
22	6"	490243	HEAT SHRINK TUBING

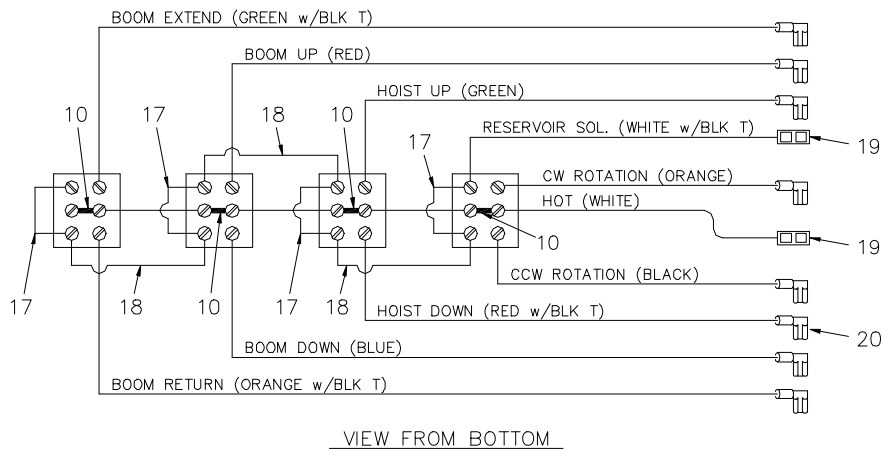
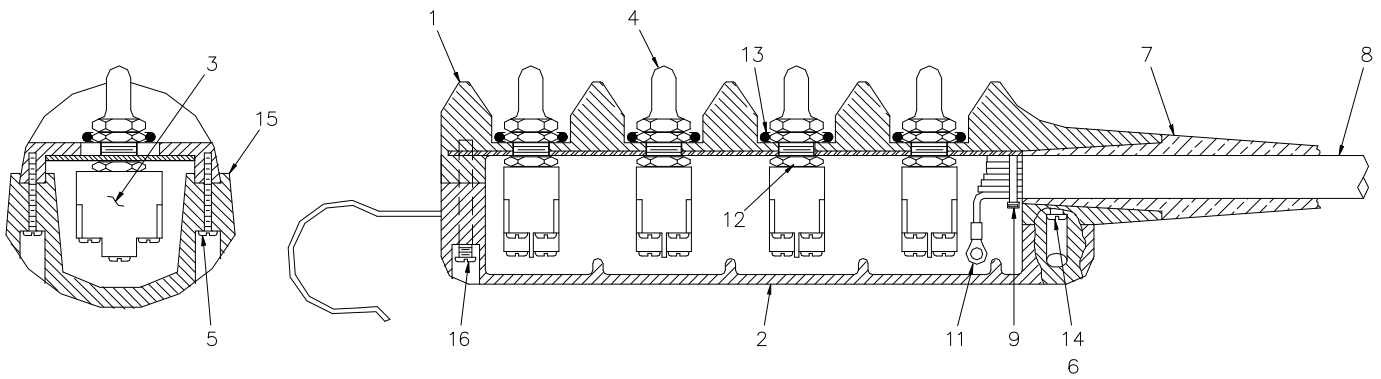

ITEM	QTY	P/N	DESCRIPTION	ITEM	QTY	P/N	DESCRIPTION
1	1	631601	PENDANT HOUSING	11	10	000101	TERMINAL, RING
2	1	631700	COVER, BOTTOM	12	4	675271	NUT, HEX
3	4	634200	SWITCH, TOGGLE	13	4	642100	"O"-RING
4	4	640302	BOOT, TOGGLE SWITCH	14	4	019700	WASHER, SP. LK. #8
5	10	005001	SCREW, PAN HD. #8 x 3/4	15	21"	800580	3/4" OKONITE RUBBER TAPE
6	2	005101	SCREW, PAN HD. #8 x 1 1/4	16	1	004700	SCREW, PAN HD. #8 x 1 1/4
7	1	633801	ADAPTER, CABLE	17	4	622346	CONDUCTOR ASSY 2 1/8" LG.
8	1	800632-004	CONDUCTOR CABLE (27')	18	3	622347	CONDUCTOR ASSY 3 1/8" LG.
9	2	634401	CABLE TIE	19	2	001102	SPLICE, BUTT (REF.)
10	4	636600	JUMPER	20	8	000405	TERMINAL, FLAG (REF.)

**NOTE:**  
ITEMS 19 & 20 ARE  
INCLUDED WITH ITEM 8

AW-480093  
PENDANT ASSEMBLY  
4 FUNCTION, NONREMOVABLE

# STANDARD 4 FUNCTION PENDANT ASSEMBLY

P/N 680037 - 6006H

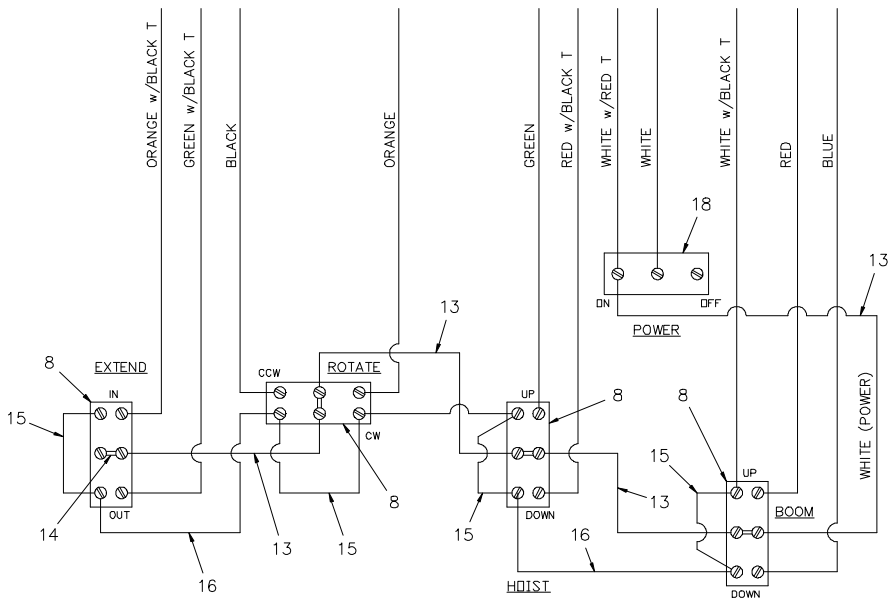
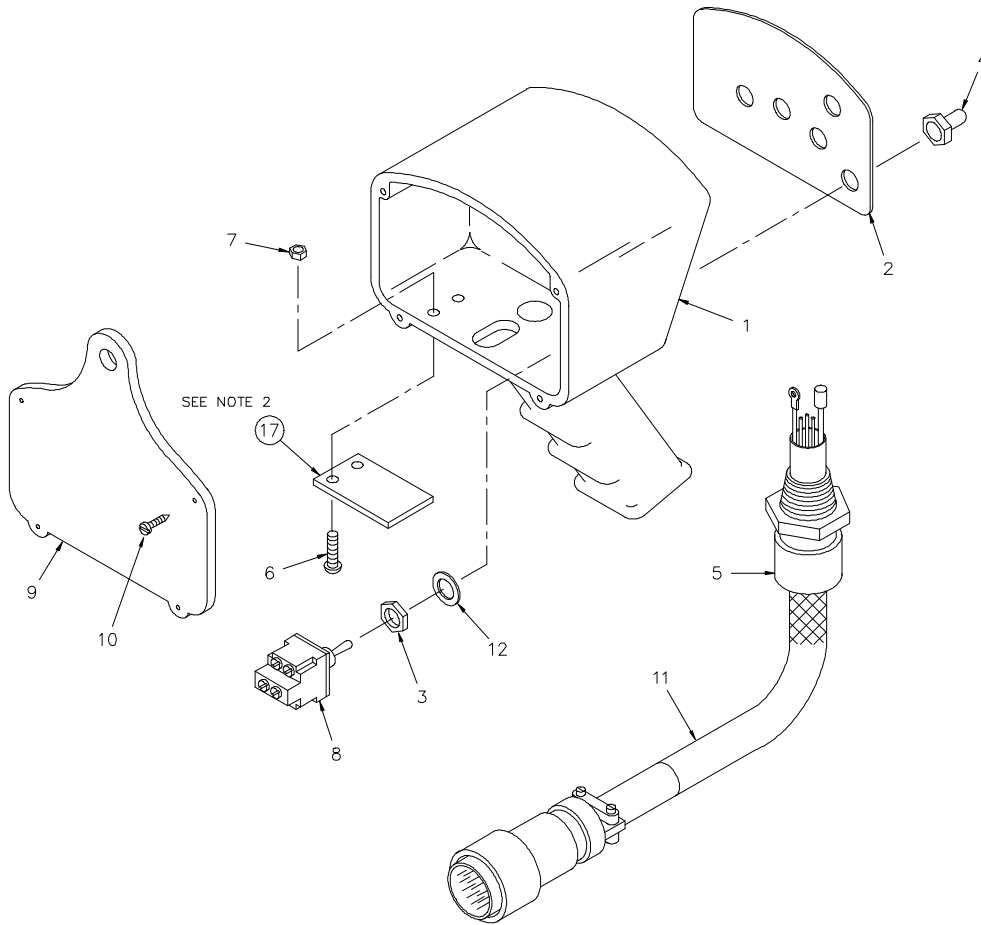

AS VIEWED FROM  
BACKSIDE OF  
PENDANT.

WIRING DIAGRAM

# ***STANDARD 4 FUNCTION PENDANT ASSEMBLY***

***P/N 680037 - 6006H***

<u>ITEM</u>	<u>QTY</u>	<u>P/N</u>	<u>DESCRIPTION</u>
1	1	480501	PENDANT HOUSING
2	1	480513	COVER PLATE DECAL
3	5	*REF	NUT
4	5	640300	TOGGLE SWITCH BOOT
5	1	480567	HUBBELL CONNECTOR CORD GRIP
6	2	002607	SCREW #10-24 NC x 3/4
7	2	015801	HEX LOCK NUT #10-24 NC
*8	4	634200	TOGGLE DPDT SWITCH
9	1	480504	BACK PLATE
10	4	480516	ST RD HD SCREW #6 x 3/4
11	1	680042	CABLE ASSEMBLY
12	5	*REF	LOCK WASHER
13	4	660302	CONDUCTOR ASSEMBLY
14	4	636600	JUMPER
15	4	622346	CONDUCTOR ASSEMBLY 2 1/8
16	3	622,347	CONDUCTOR ASSEMBLY 3 1/8
17	1	480598	TRIGGER OPENING COVER
18	1	750090	TOGGLE ON/OFF SWITCH
19	2	750737	CABLE TIE

\*NOTE: Item 8 includes items 3 & 12.

# PROPORTIONAL 4 FUNCTION PENDANT ASSEMBLY

P/N 680038 - 6006H

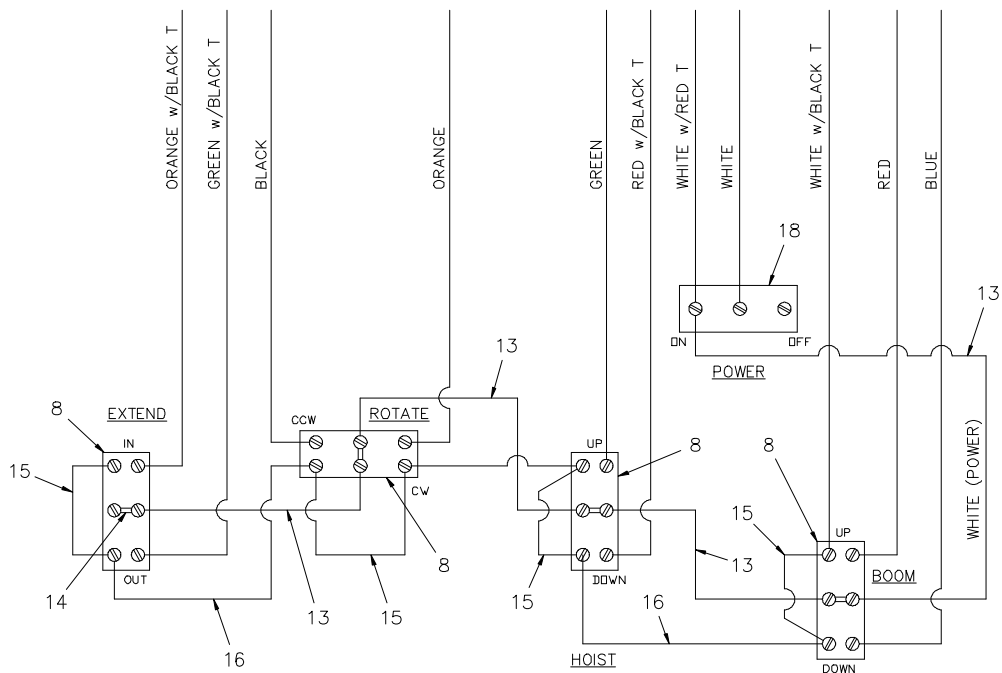
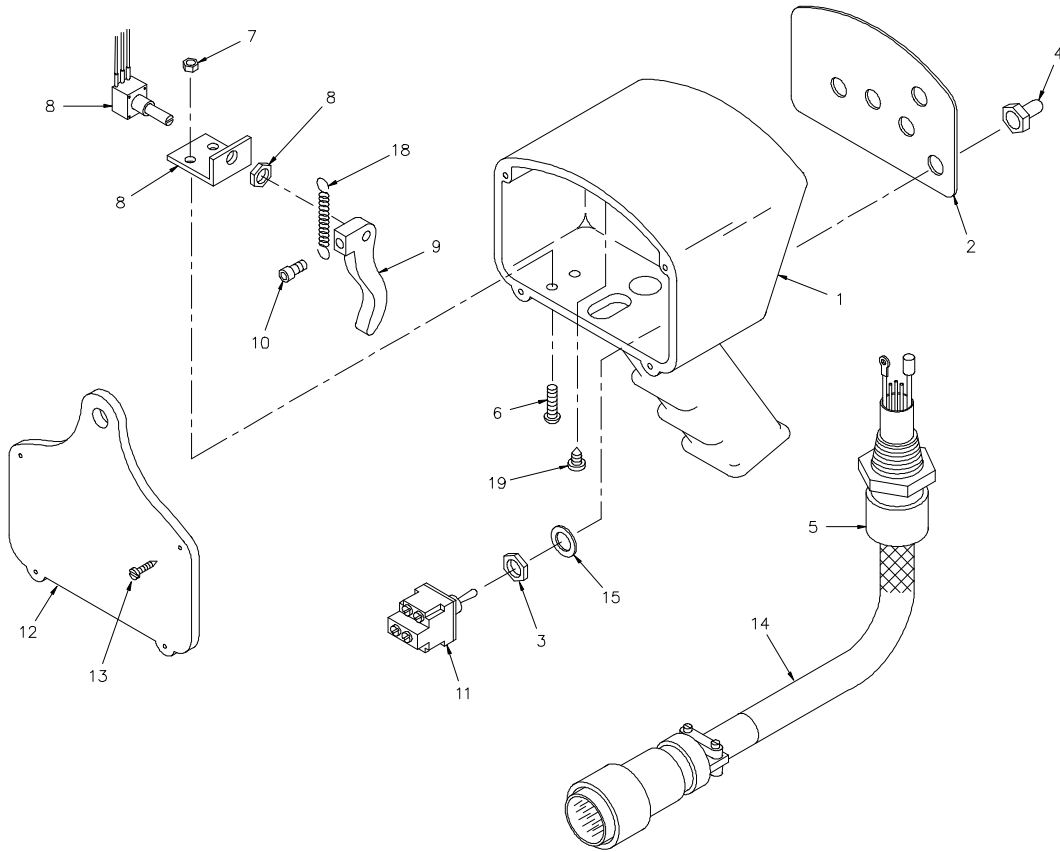

AS VIEWED FROM  
BACKSIDE OF  
PENDANT.

## WIRING GUIDE

# ***PROPORTIONAL 4 FUNCTION PENDANT ASSEMBLY***

***P/N 680038 - 6006H***

<u>ITEM</u>	<u>QTY</u>	<u>P/N</u>	<u>DESCRIPTION</u>
1	1	480501	PENDANT HOUSING
2	1	480513	COVER PLATE DECAL
3	4	*REF	NUT
4	4	640300	TOGGLE SWITCH BOOT
5	1	480567	HUBBELL CONNECTOR CORD GRIP
6	2	002607	SCREW #10-24 NC x 3/4
7	2	015801	HEX LOCK NUT #10-24 NC
8	1	480507	POTENTIOMETER ASSEMBLY
9	1	480506	TRIGGER
10	1	480517	SOC HD SCREW #10-32 NF x 5/8
*11	4	634200	TOGGLE DPDT SWITCH
12	1	480504	BACK PLATE
13	4	480516	ST RD HD SCREW #6 x 3/4
14	1	680043	CABLE ASSEMBLY
15	4	*REF	LOCK WASHER
16	4	660302	CONDUCTOR ASSEMBLY
17	1	480524	CONDUCTOR ASSEMBLY
18	1	480523	TRIGGER RETURN SPRING
19	1	005003	PAN HD ST SCREW #6 x 3/8
20	4	636600	JUMPER
21	4	622346	CONDUCTOR ASSEMBLY 2 1/8
22	3	622347	CONDUCTOR ASSEMBLY 3 1/8
23	2	750737	CABLE TIE
24	1	750090	TOGGLE ON/OFF SWITCH

\*NOTE: Item 11 includes items 3 & 15.



# STANDARD 8 FUNCTION PENDANT ASSEMBLY

P/N 680039 - 6006H

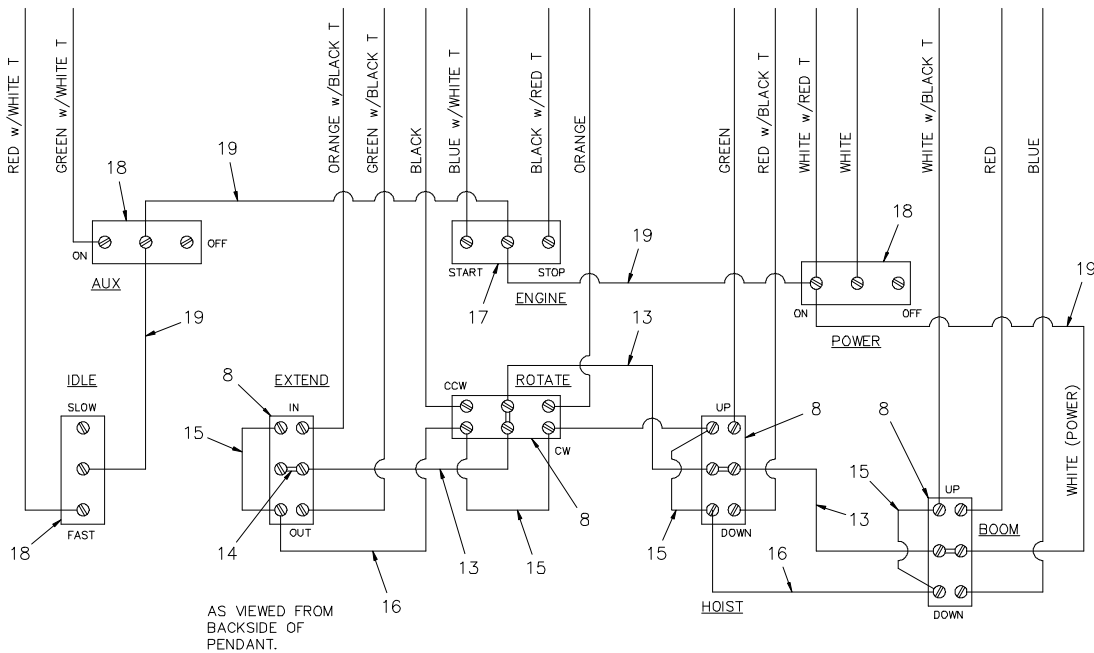
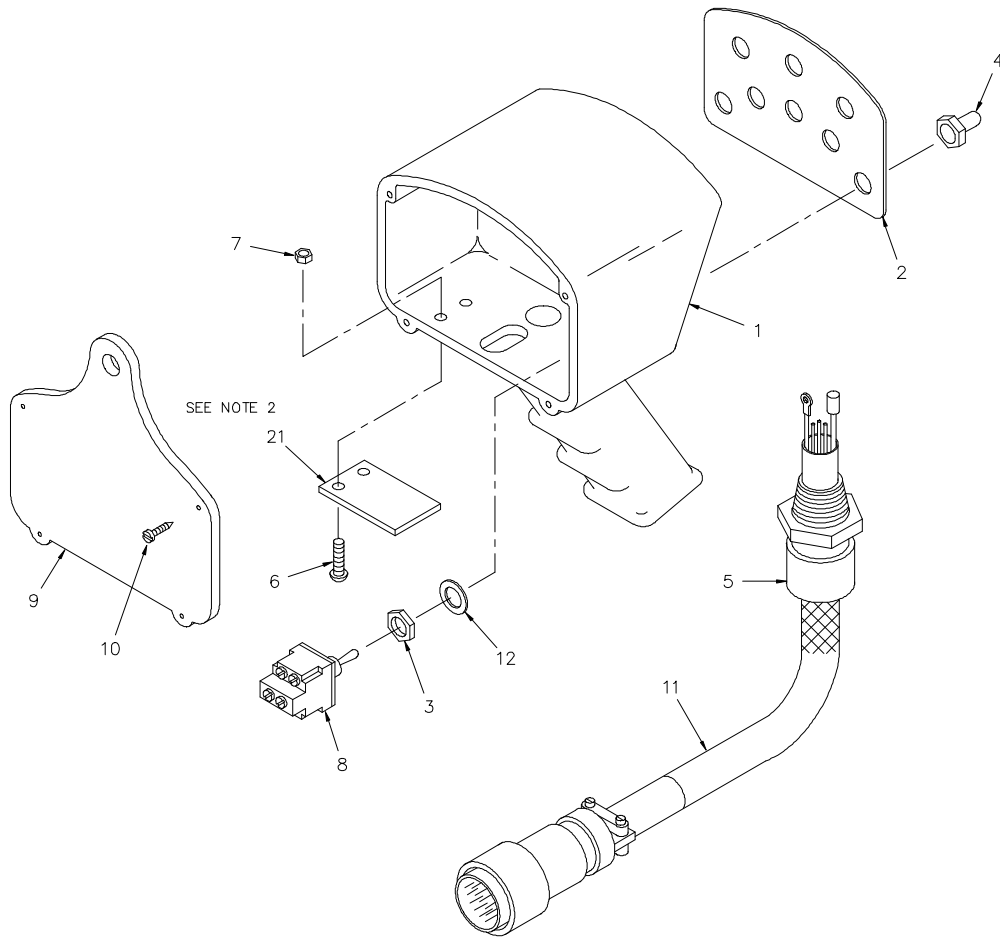

WIRING DIAGRAM

# ***STANDARD 8 FUNCTION PENDANT ASSEMBLY***

***P/N 680039 - 6006H***

<u>ITEM</u>	<u>QTY</u>	<u>P/N</u>	<u>DESCRIPTION</u>
1	1	480501	PENDANT HOUSING
2	1	480513	COVER PLATE DECAL
3	8	*REF	NUT
4	8	640300	TOGGLE SWITCH BOOT
5	1	480567	HUBBELL CONNECTOR CORD GRIP
6	2	002607	SCREW #10-24 NC x 3/4
7	2	015801	HEX LOCK NUT #10-24 NC
*8	4	634200	TOGGLE DPDT SWITCH
9	1	480504	BACK PLATE
10	4	480516	ST RD HD SCREW #6 x 3/4
11	1	680041	CABLE ASSEMBLY
12	8	*REF	LOCK WASHER
13	3	660302	CONDUCTOR ASSEMBLY
14	4	636600	JUMPER
15	4	622346	CONDUCTOR ASSEMBLY 2 1/8
16	3	622347	CONDUCTOR ASSEMBLY 3 1/8
17	1	622000	TOGGLE SPDT SWITCH
18	3	750090	TOGGLE ON/OFF SWITCH
19	1	480526	CONDUCTOR ASSEMBLY
20	2	750737	CABLE TIE
21	1	480598	TRIGGER OPENING COVER

\*NOTE: Item 8 includes items 3 & 12.

# PROPORTIONAL 8 FUNCTION PENDANT ASSEMBLY

P/N 680040 - 6006H

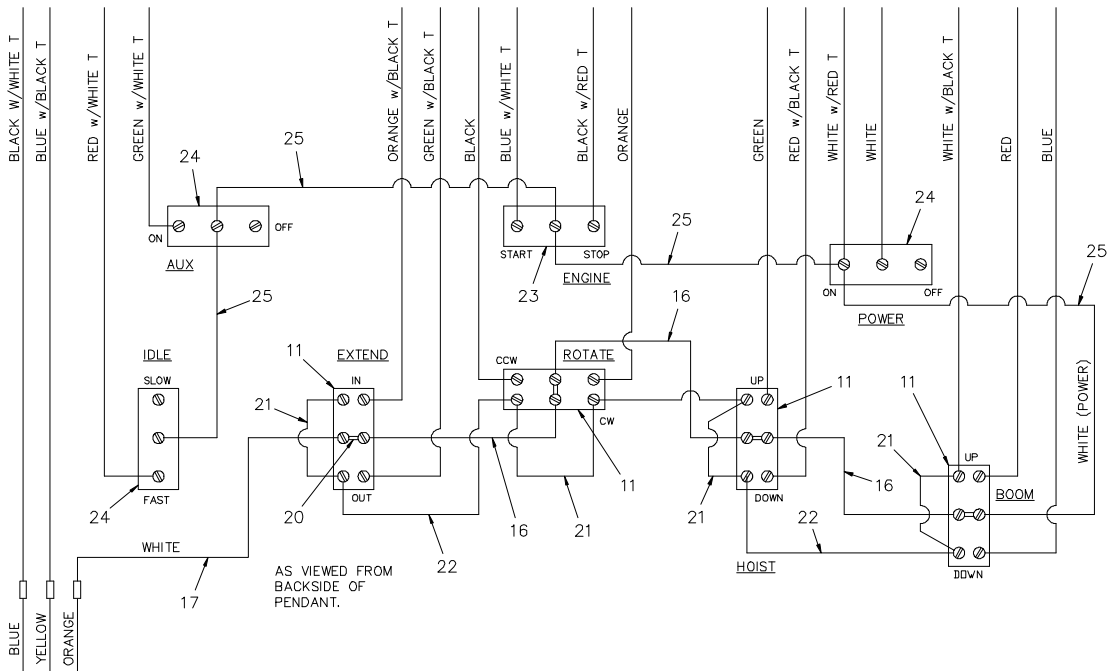
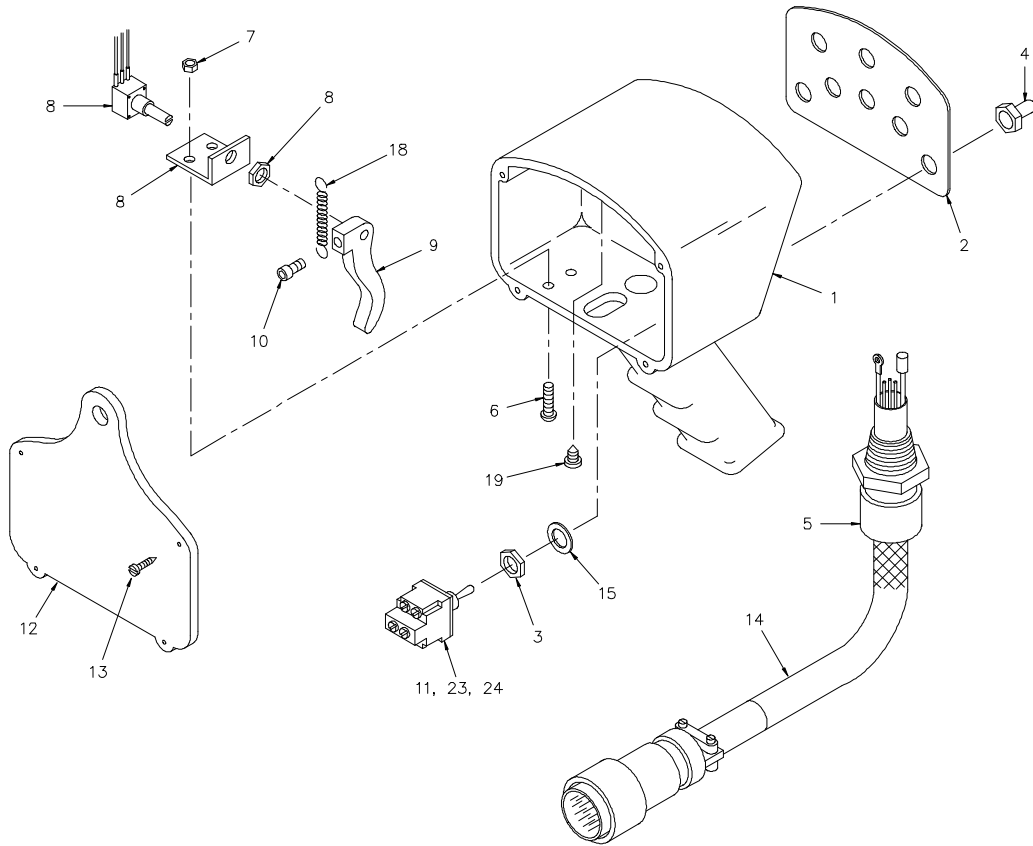

**NOTES:**

# ***PROPORTIONAL 8 FUNCTION PENDANT ASSEMBLY***

***P/N 680040 - 6006H***

<u>ITEM</u>	<u>QTY</u>	<u>PART NUMBER</u>	<u>DESCRIPTION</u>
1	1	480501	PENDANT HOUSING
2	1	480518	COVER PLATE DECAL
3	8	*REF	NUT
4	8	640300	TOGGLE SWITCH BOOT
5	1	480567	HUBBELL CONNECTOR CORD GRIP
6	2	002607	SCREW #10 NC x 3/4
7	2	015801	HEX LOCK NUT #10 NC
8	1	480507	POTENTIOMETER ASSEMBLY
9	1	480506	TRIGGER
10	1	480517	SOC HD SCREW #10 NF x 5/8
11	4	634200	TOGGLE DPDT SWITCH
12	1	480504	BACK PLATE
13	4	001004	ST RD HD SCREW #6 x 3/4
14	1	680113	CABLE ASSEMBLY
15	8	*REF	LOCK WASHER
16	3	660302	CONDUCTOR ASSEMBLY
17	1	480524	CONDUCTOR ASSEMBLY
18	1	480523	TRIGGER RETURN SPRING
19	1	005003	PAN HD ST SCREW #6 x 3/8
20	4	636600	JUMPER
21	4	622346	CONDUCTOR ASSEMBLY 2 1/8
22	3	622347	CONDUCTOR ASSEMBLY 3 1/8
23	1	622000	TOGGLE SPDT SWITCH
24	3	750090	TOGGLE ON/OFF SWITCH
25	1	480526	CONDUCTOR ASSEMBLY
26	2	750737	CABLE TIE

1. ITEMS 5 & 14 MAY BE PURCHASED AS **REPLACEMENT CABLE ASSEMBLY** USING **P/N 380000**.
2. ITEMS 6, 7, 8, 9, 10, 18, & 19 MAY BE PURCHASED AS A **REPLACEMENT POTENTIOMETER KIT** USING **P/N 380003**.
3. ITEMS 1, 2, 12, & 13 MAY BE PURCHASED AS A **REPLACEMENT HOUSING KIT** USING **P/N 380002**.
4. ITEMS 3, 4, 11, & 15 MAY BE PURCHASED AS A **REPLACEMENT DPDT SWITCH KIT** USING **P/N 380005**.
5. ITEMS 3, 4, 15, & 24 MAY BE PURCHASED AS A **REPLACEMENT ON/OFF SWITCH KIT** USING **P/N 380001**.
6. ITEMS 3, 4, 11, & 23 MAY BE PURCHASED AS A **REPLACEMENT SPDT SWITCH KIT** USING **P/N 380004**.

# PENDANT CABLE ASSEMBLY

P/N 680041 - 6006H

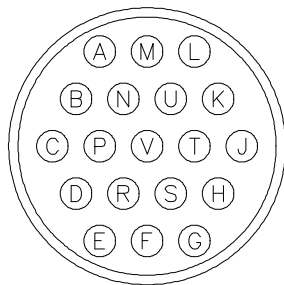
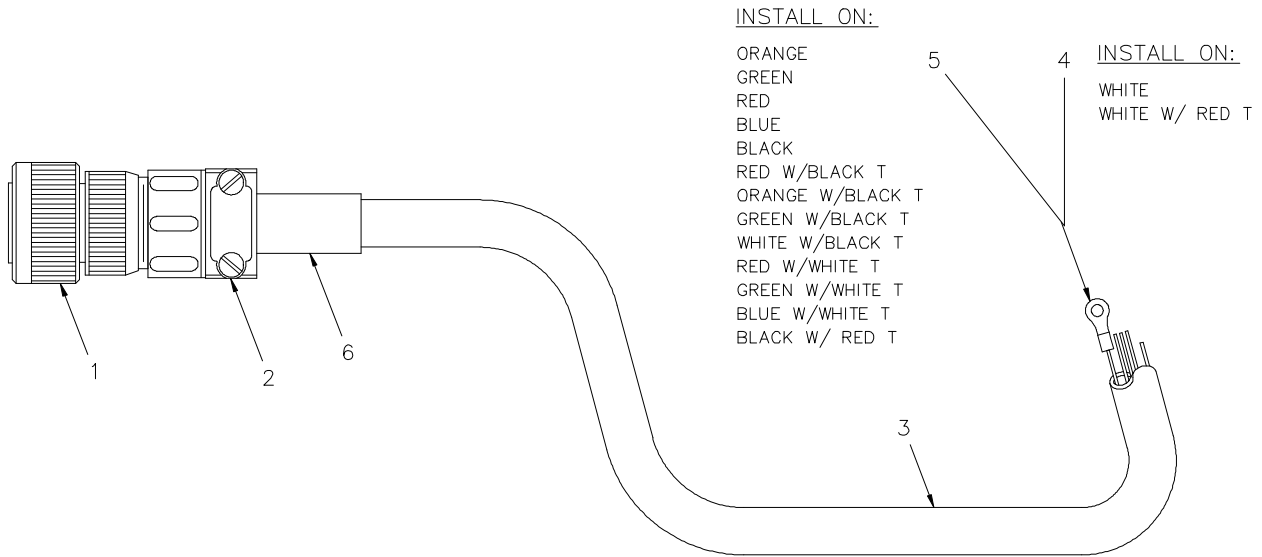

## WIRING GUIDE

A-RED	L-WHITE
B-GREEN	M-BLUE W/BLACK T
C-ORANGE	N-BLACK W/WHITE T
D-RED W/WHITE T	P-GREEN W/WHITE T
E-BLACK	R-BLUE W/WHITE T
F-RED W/BLACK T	S-BLACK W/RED T
G-BLUE	T-WHITE W/RED T
H-ORANGE W/BLACK T	U-ORANGE W/RED T
J-GREEN W/BLACK T	V-BLUE W/RED T
K-WHITE W/BLACK T	

ITEM	QTY	P/N	DESCRIPTION
1	1	366098	19 PIN BAYONET PLUG
2	1	480515	CABLE CLAMP
3	30'	480594	19 PIN CONDUCTOR CABLE
4	2	000101	RING TERMINAL #6 / 14-16 GA
5	13	002012	RING TERMINAL #6 / 18-22 GA
6	6"	490243	HEAT SHRINK TUBING x 6"

# PENDANT CABLE ASSEMBLY

P/N 680113 - 6006H

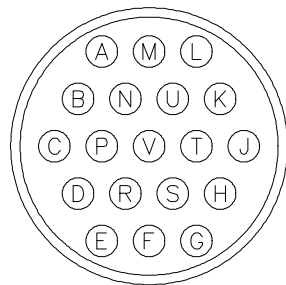
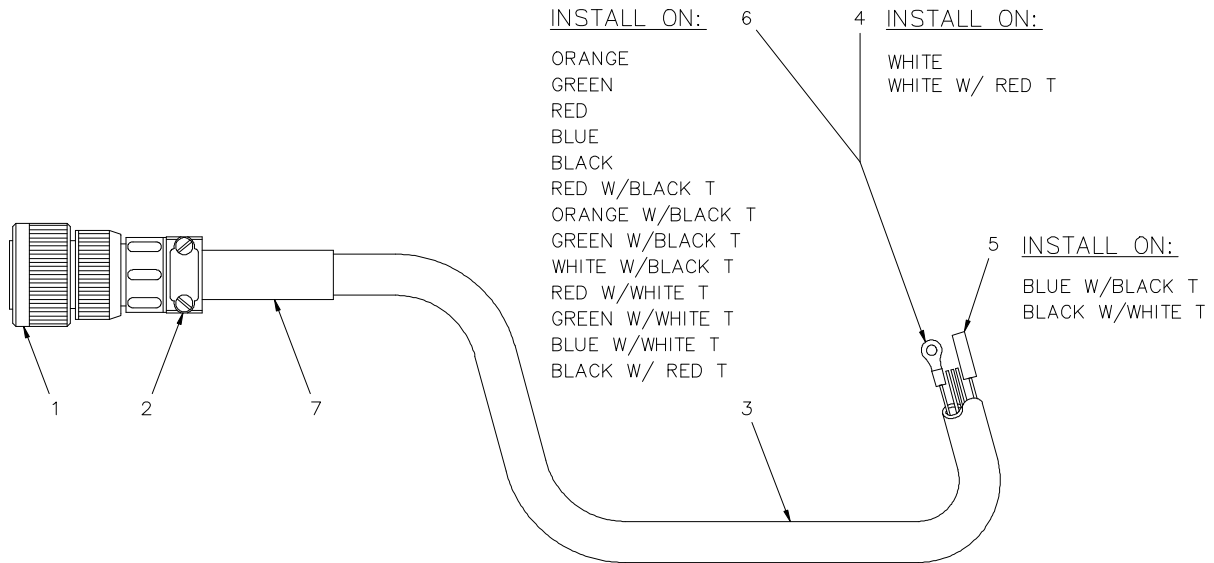

## WIRING GUIDE

A-RED	L-WHITE
B-GREEN	M-BLUE W/BLACK T
C-ORANGE	N-BLACK W/WHITE T
D-RED W/WHITE T	P-GREEN W/WHITE T
E-BLACK	R-BLUE W/WHITE T
F-RED W/BLACK T	S-BLACK W/RED T
G-BLUE	T-WHITE W/RED T
H-ORANGE W/BLACK T	U-ORANGE W/RED T
J-GREEN W/BLACK T	V-BLUE W/RED T
K-WHITE W/BLACK T	

ITEM	QTY	P/N	DESCRIPTION
1	1	366098	19 PIN BAYONET PLUG
2	1	480515	CABLE CLAMP
3	30'	480594	19 PIN CONDUCTOR CABLE
4	2	000101	RING TERMINAL #6 / 14-16 GA
5	2	480510	RING TERMINAL #6 / 14-16 GA
6	13	002012	FEMALE BULLET CONNECTOR
7	6"	490243	HEAT SHRINK TUBING x 6"

# PENDANT CABLE ASSEMBLY

P/N 680042 - 6006H

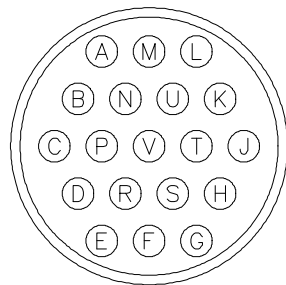
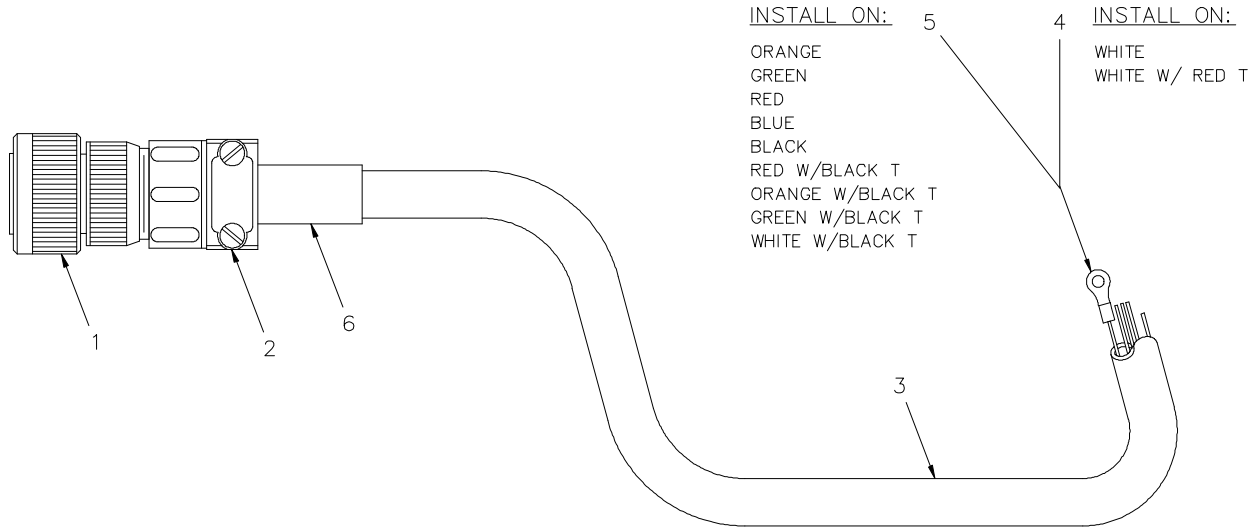

## WIRING GUIDE

A-RED	L-WHITE
B-GREEN	M-BLUE W/BLACK T
C-ORANGE	N-BLACK W/WHITE T
D-RED W/WHITE T	P-GREEN W/WHITE T
E-BLACK	R-BLUE W/WHITE T
F-RED W/BLACK T	S-BLACK W/RED T
G-BLUE	T-WHITE W/RED T
H-ORANGE W/BLACK T	U-ORANGE W/RED T
J-GREEN W/BLACK T	V-BLUE W/RED T
K-WHITE W/BLACK T	

ITEM	QTY	P/N	DESCRIPTION
1	1	366098	19 PIN BAYONET PLUG
2	1	480515	CABLE CLAMP
3	30'	480594	19 PIN CONDUCTOR CABLE
4	2	000101	RING TERMINAL #6 / 14-16 GA
5	9	002012	RING TERMINAL #6 / 18-22 GA
6	6"	490243	HEAT SHRINK TUBING x 6"

# PENDANT CABLE ASSEMBLY

P/N 680043 - 6006H

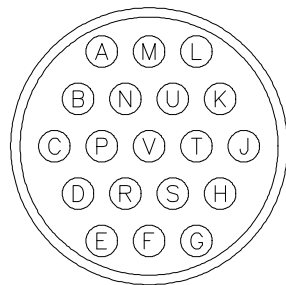
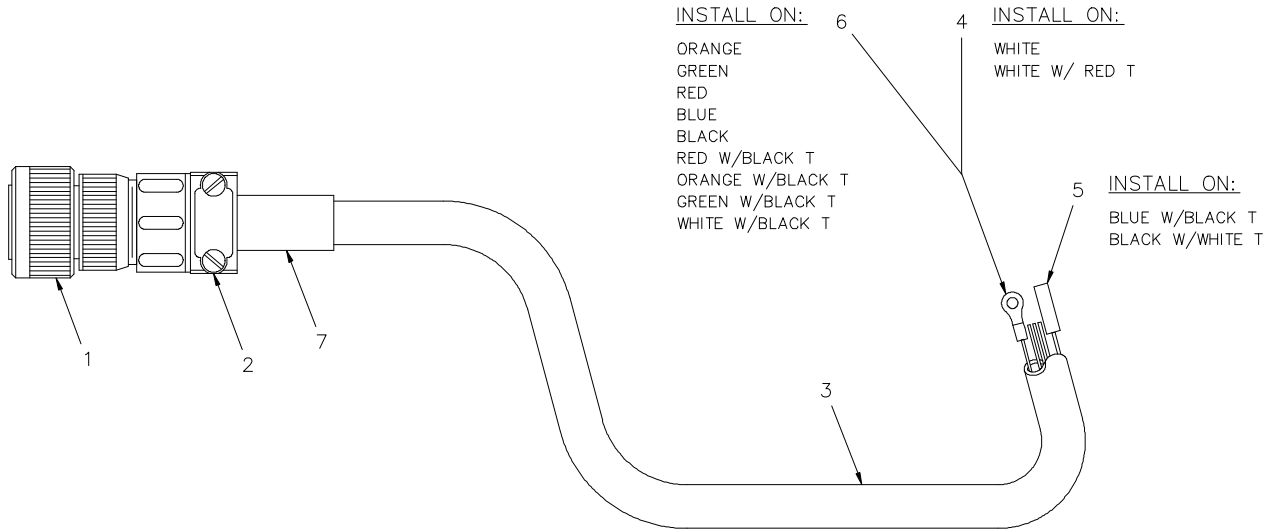

## WIRING GUIDE

A-RED	L-WHITE
B-GREEN	M-BLUE W/BLACK T
C-ORANGE	N-BLACK W/WHITE T
D-RED W/WHITE T	P-GREEN W/WHITE T
E-BLACK	R-BLUE W/WHITE T
F-RED W/BLACK T	S-BLACK W/RED T
G-BLUE	T-WHITE W/RED T
H-ORANGE W/BLACK T	U-ORANGE W/RED T
J-GREEN W/BLACK T	V-BLUE W/RED T
K-WHITE W/BLACK T	

ITEM	QTY	P/N	DESCRIPTION
1	1	366098	19 PIN BAYONET PLUG
2	1	480515	CABLE CLAMP
3	30'	480594	19 PIN CONDUCTOR CABLE
4	2	000101	RING TERMINAL #6 / 14-16 GA
5	2	480510	FEMALE BULLET CONNECTOR
6	9	002012	RING TERMINAL #6 / 18-22 GA
7	6"	490243	HEAT SHRINK TUBING x 6"



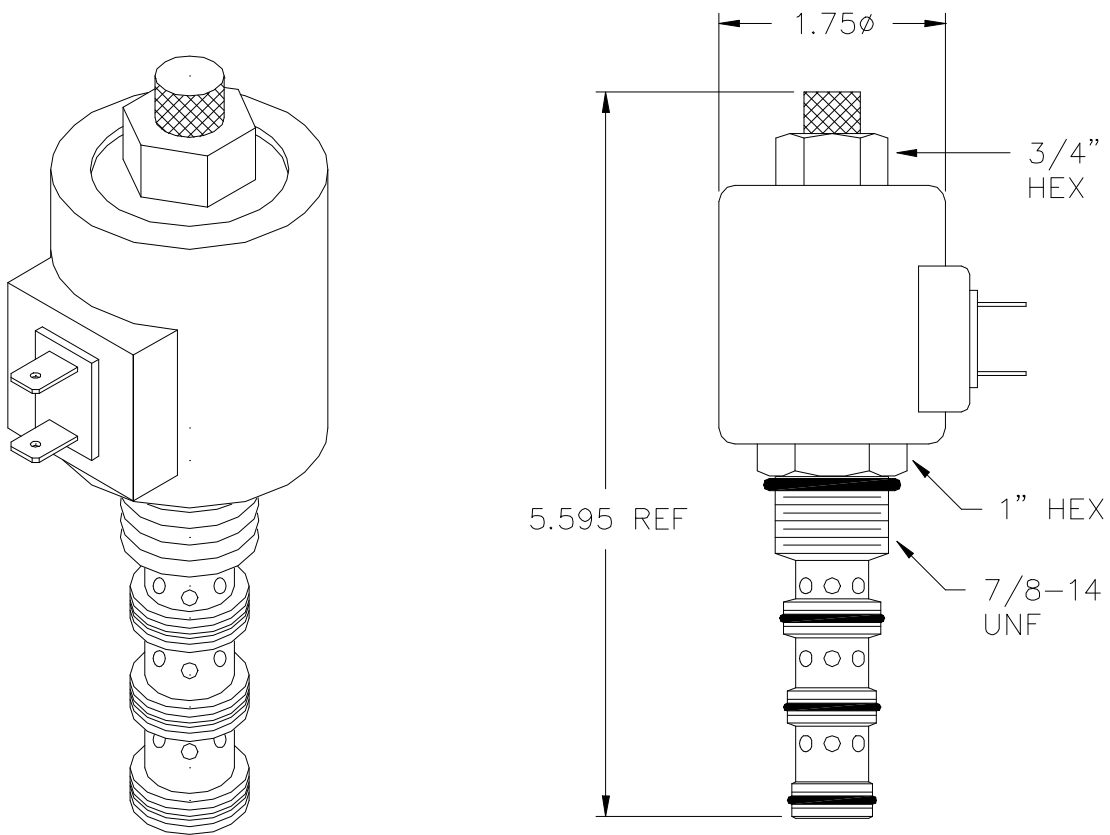

NOTES:

- 1.) FOR SEAL KIT, ORDER PART NO. 480184-002
- 2.) FOR REPLACEMENT COIL, ORDER PART NO. 480184-003

AW-480184  
CARTRIDGE VALVE

# ***FM REMOTE TRANSMITTER***

## ***P/N 480623***

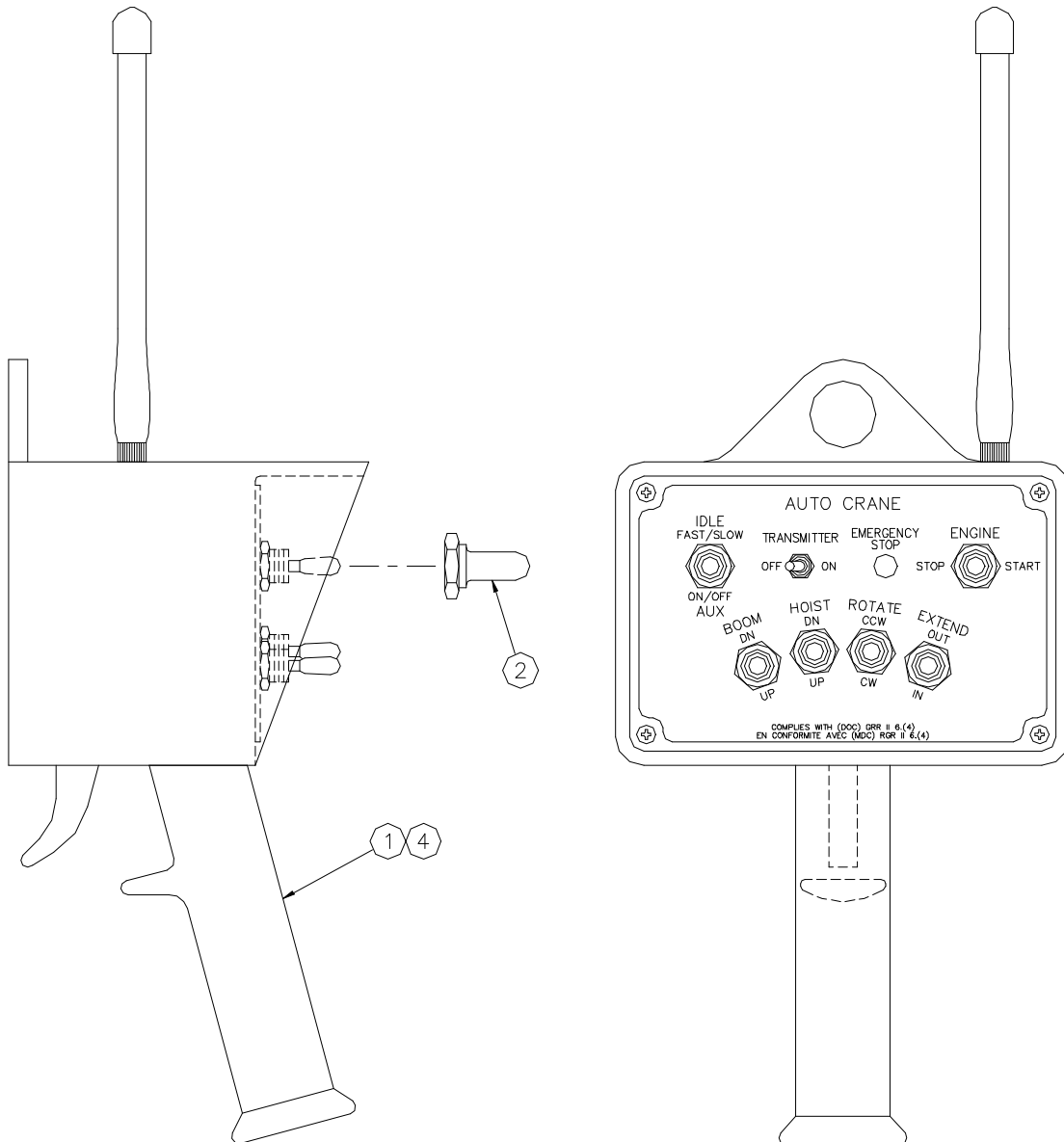

<b>ITEM</b>	<b>QTY</b>	<b>P/N</b>	<b>DESCRIPTION</b>
1	1	480621-002	FM Remote Transmitter (Toggle Pistol Grip)
2	6	640300	Toggle Boot
4	1	480605	4 Volt Battery

# HYDRAULIC ASSEMBLY - P/N 366160

## 6006H

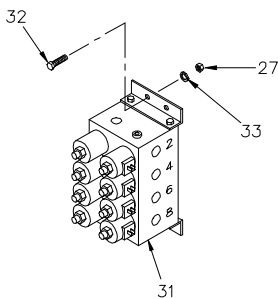
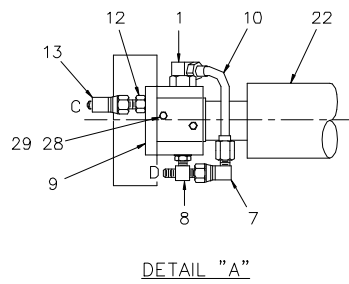
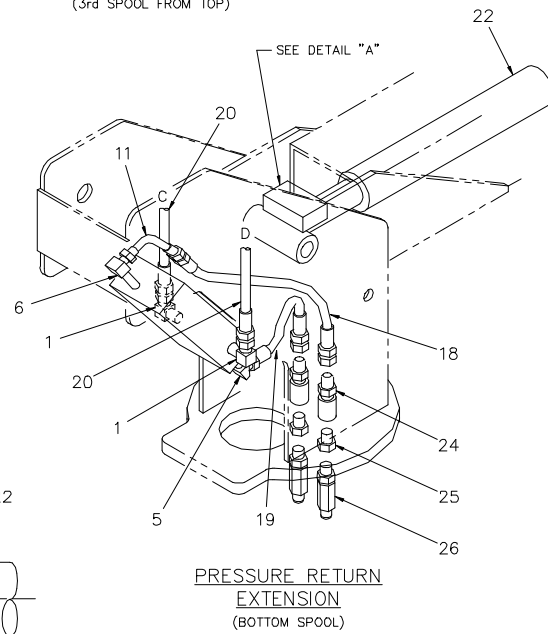
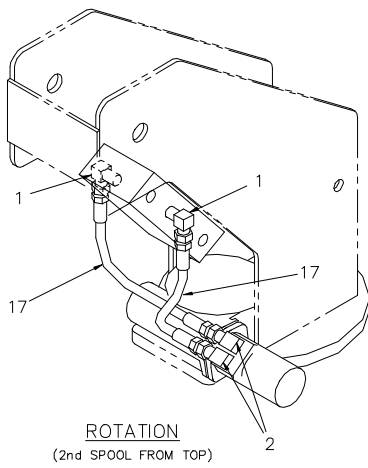
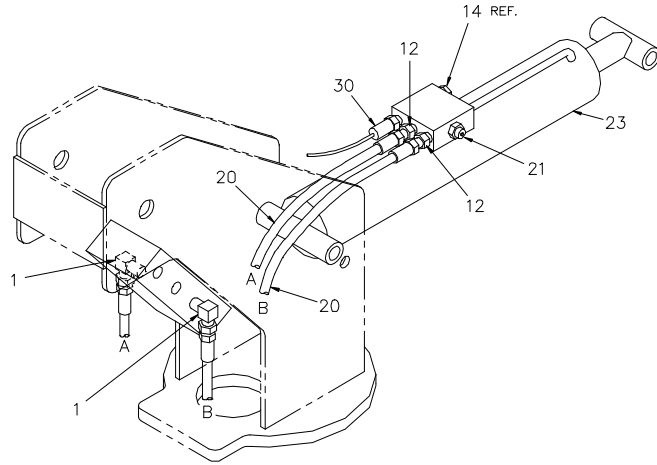
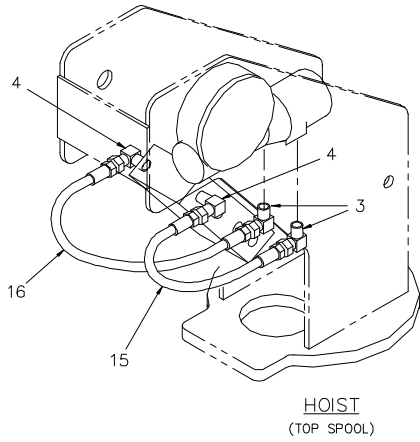

# ***HYDRAULIC ASSEMBLY - P/N 366160***

## ***6006H***

<b><u>ITEM</u></b>	<b><u>QTY</u></b>	<b><u>P/N</u></b>	<b><u>DESCRIPTION</u></b>
1	7	200892	90° ELLBOW -6 NPT/-6 JIC
2	2	202759	90° ELLBOW -8 NPT/-6 JIC
3	2	360043	90° ELLBOW -8 NPT/-8 JIC
4	2	360044	90° ELLBOW -6 NPT/-8 JIC
5	1	480190	90° ELLBOW -6 NPT/-8 JIC (LONG)
6	1	480213	90° ELLBOW -6 NPT/-8 JIC (MED. LG.)
7	1	480194	90° ELLBOW -6 JIC SWIVEL/-6 JIC
8	1	241168	TEE -6 O-RING/-6 JIC RUN
9	1	330412	COUNTER BALANCE VALVE
10	1	480212	TUBE ASSEMBLY (EXT. CYL.
11	1	480211	TUBE ASSEMBLY (PRESSURE)
12	3	200876	ADAPTER -6 O-RING/-6 JIC
13	1	330647	45° ELLBOW SWIVEL -6 JIC
14	1	REF.	PLUG -6 ORB
15	1	480202	HOSE ASSEMBLY
16	1	480203	HOSE ASSEMBLY
17	2	480204	HOSE ASSEMBLY
18	1	360578	HOSE ASSEMBLY
19	1	360579	HOSE ASSEMBLY
20	4	480208	HOSE ASSEMBLY
21	1	480188	COUNTER BALANCE VALVE CARTRIDGE
22	1	366162	EXTENSION CYLINDER
23	1	366805	BOOM UP CYLINDER
24	2	360054	ADAPTER -8 NPT/-8 JIC
25	2	750413	REDUCER -8 NPT/-6 NPTF
26	2	750412	SWIVEL JOINT
27	4	017100	HEX NUT 3/8-16 NC
28	2	020200	WASHER SP LK 1/4
29	2	005810	HEX HD SCREW 1/4 NC x 1 3/4
30	1	320543	LOAD SENSOR
31	1	360620	VALVE BANK ASSEMBLY
32	4	008701	HEX HD SCREW 3/8-16 NC x 1
33	4	021100	WASHER SP LK 3/8

# HYDRAULIC SCHEMATIC

## 6006H

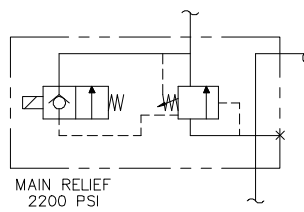
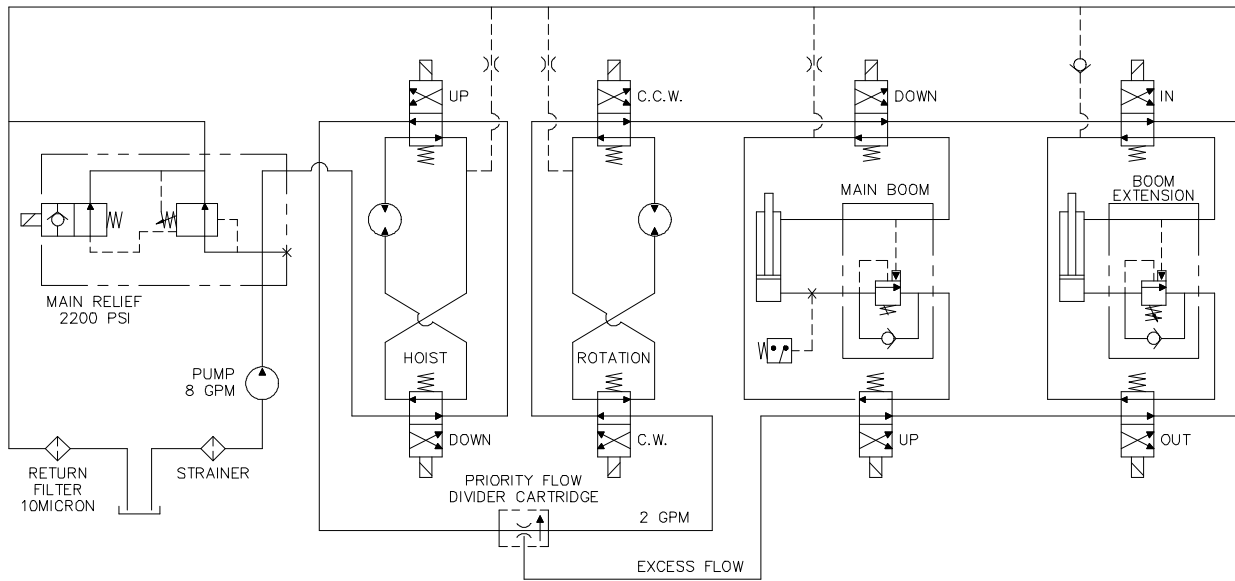

RELIEF VALVE SHOWN  
WITH SOLENOID ENERGIZED

# HYDRAULIC SCHEMATIC PROPORTIONAL

## 6006H

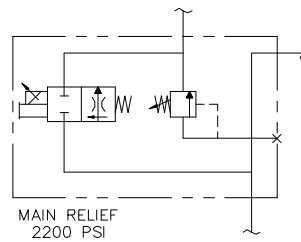
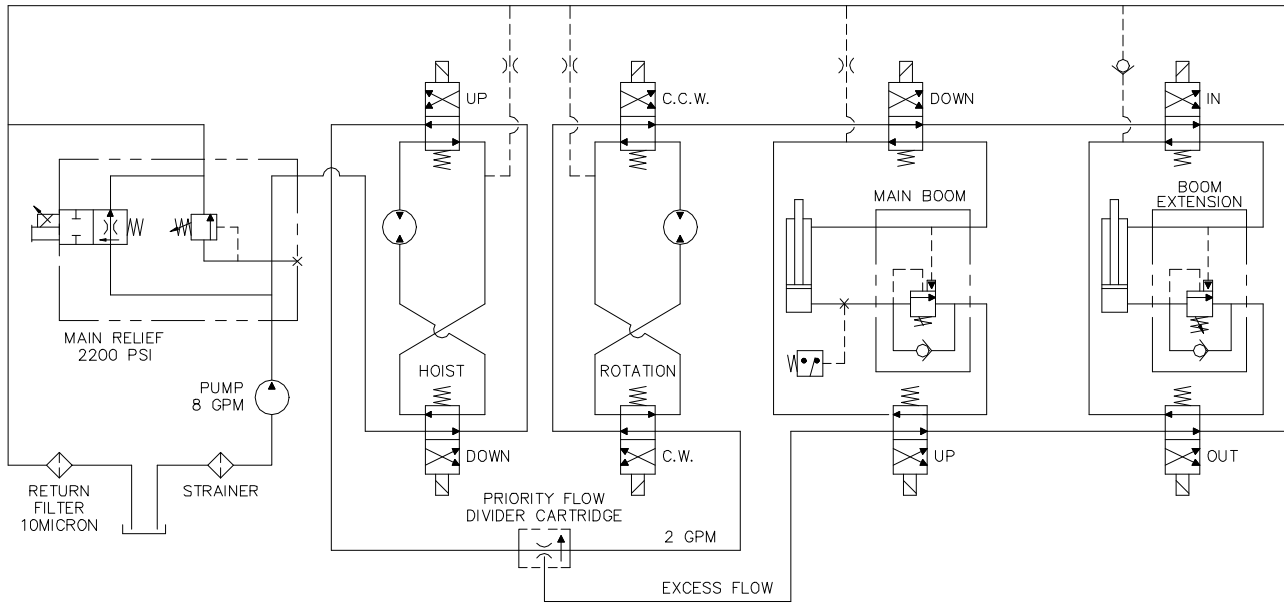

RELIEF VALVE SHOWN  
WITH SOLENOID ENERGIZED

# HYDRAULIC DIRECT MOUNT PUMP

P/N 480018 - 6006H SERIES

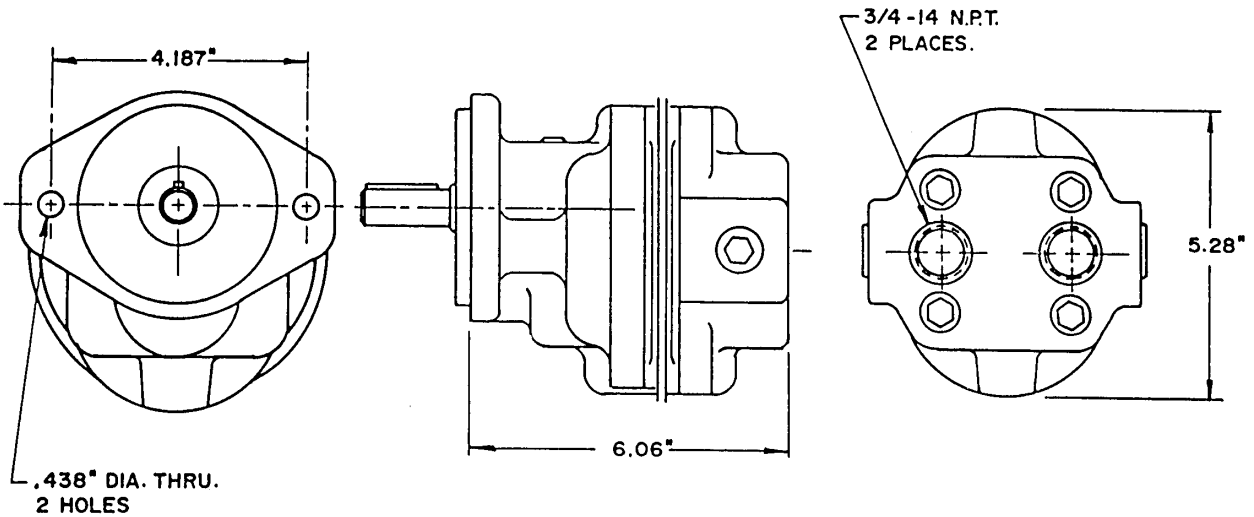

Adapter: SAE "A" 2 bolt flange (direct mount only).  
Shaft: Straight shaft key 3/4 dia. x 2 3/4 long.  
3/16 sq. key x 1 5/8 long.

## NOTES:

1. Pump speed - 1000 RPM (standard).
2. To order **HYDRAULIC PUMP ASSEMBLY** use **P/N 480022** - which consists of HYDRAULIC PUMP (P/N 480018), 3/4-14NPT/1-5/16-12 JIC SUCTION ADAPTER (P/N 360055) SUCTION AND 3/4-14 NPT/ 1 1/16-12 JIC PRESSURE ADAPTER (750399).
3. For **SEAL KIT** use **P/N 480018-001**.
4. For **SERVICE KIT** use **P/N 480018-002**.

NOTE:  
RELIEF VALVE MUST BE  
LOCATED BETWEEN PUMP  
AND ANY OTHER VALVES  
AND ACCESSORIES.

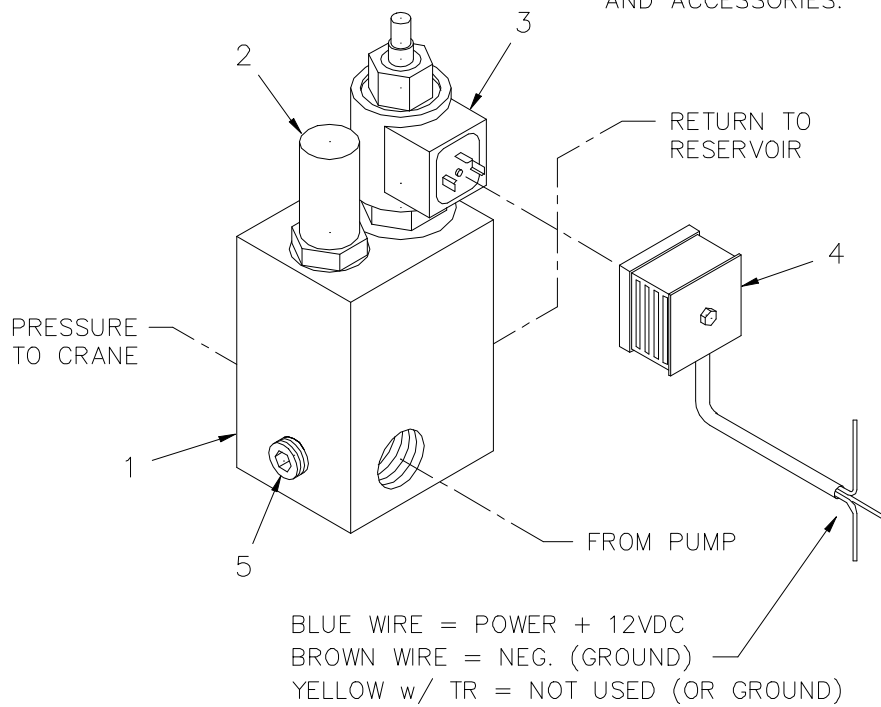

ITEM	QTY	P/N	DESCRIPTION
1	1	366211	VALVE, VENTED RELIEF 2200 PSI
2		366211-001	REPLACEMENT CARTRIDGE
3	1	480137	VALVE, DIRECTIONAL SOLENOID
4	1	480613	DIN CONNECTOR
5	1	000209	PLUG, PIPE - SOC. 1/4"

AW-366212  
VENTED RELIEF VALVE  
ASSEMBLY w/ SOLENOID (2200 PSI)



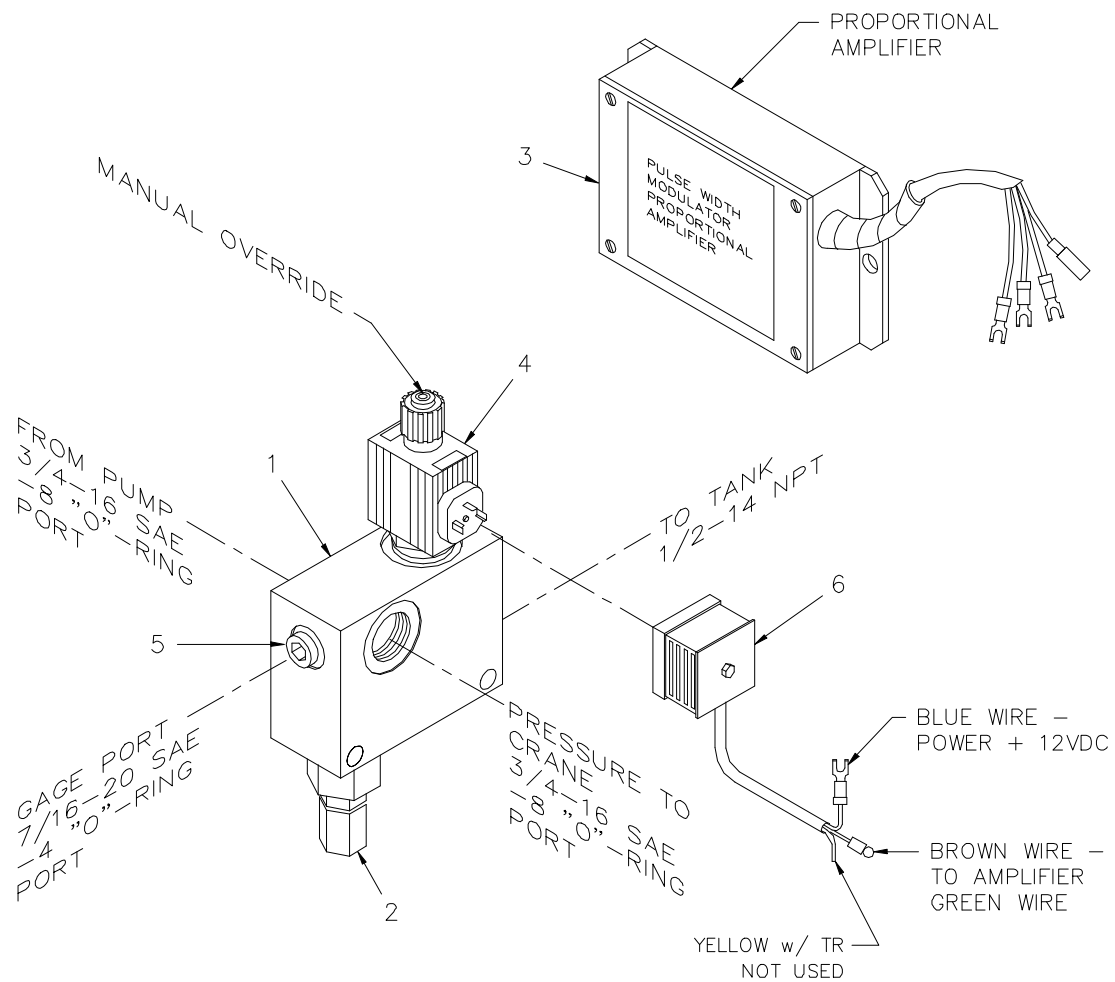

ITEM	QTY	P/N	DESCRIPTION
1	1	480521	MANIFOLD, BLOCK
2	1	360157-002	VALVE, RELIEF
3	1	480522	AMPLIFIER, PROP. (IN SHIP KIT)
4	1	480520	VALVE, SOLENOID
5	1	000211	PLUG, -4 SAE "O"-RING
6	1	480529	DIN CONNECTOR ASSEMBLY

AW-480525  
HYDRAULIC MANIFOLD ASSEMBLY  
PROPORTIONAL

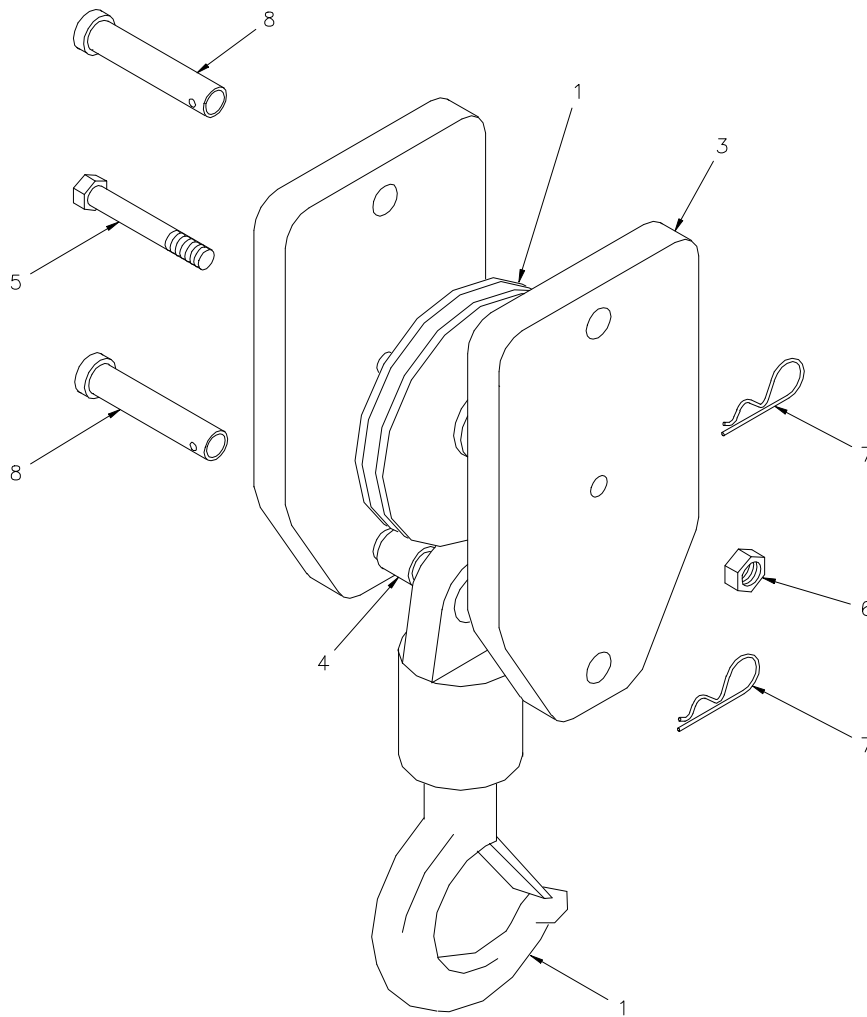

<u>ITEM</u>	<u>QTY</u>	<u>P/N</u>	<u>DESCRIPTION</u>	<u>ITEM</u>	<u>QTY</u>	<u>P/N</u>	<u>DESCRIPTION</u>
1	1	480130	SHEAVE ASSEMBLY	5	1	006801	SCW, HX HD 1/2-20 x 4 LG.
2	1	200197	HOOK, SWIVEL	6	1	017800	NUT, HEX LOCK 1/2-20NF
3	2	360601	BLOCK SIDE PLATE	7	2	360124	PIN, HITCH
4	1	240237	SPACER, BUSHING 1" O.D.	8	2	360605	PIN, BLOCK

AW-366203  
TRAVELING BLOCK ASSEMBLY

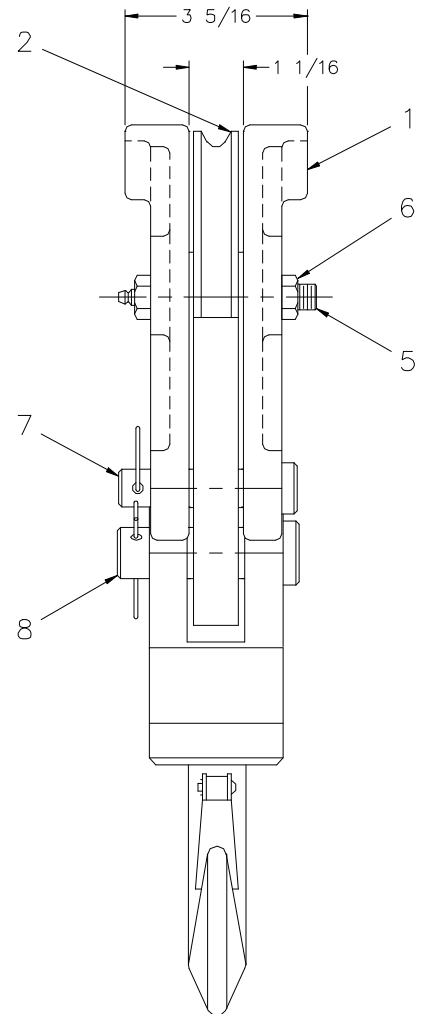
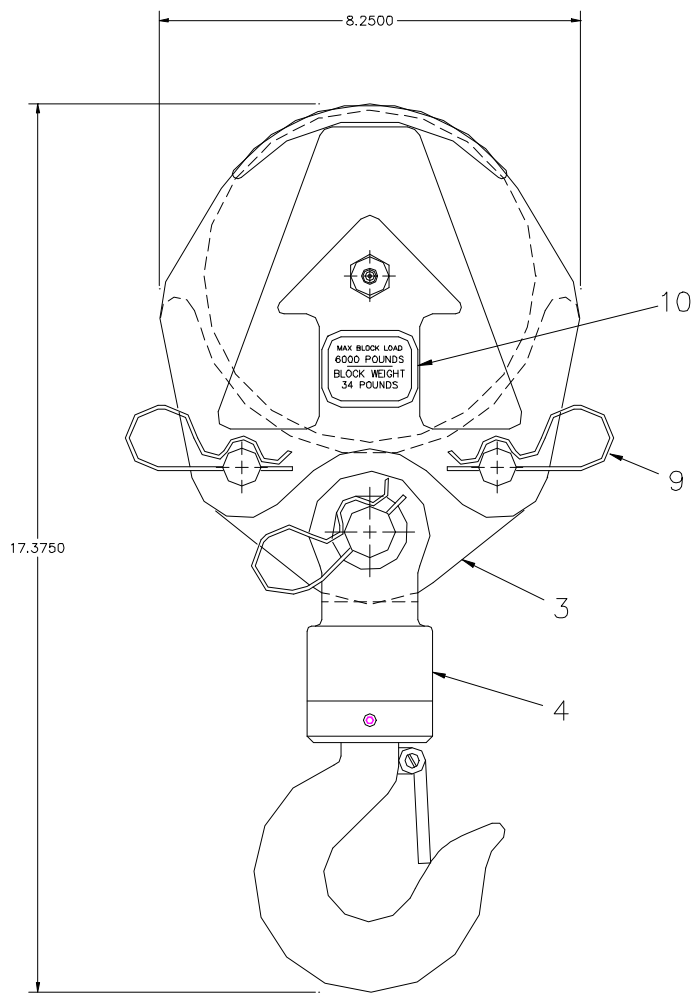

ITEM	QTY	P/N	DESCRIPTION	ITEM	QTY	P/N	DESCRIPTION
1	2	480362	SIDE PLATE (MACH.)	6	1	017800	NUT, HX LK 1/2-20NF
2	1	480130	SHEAVE ASSEMBLY	7	2	480367	PIN, BLOCK
3	1	480364	TACKLE, LOWER	8	1	480368	PIN, SWIVEL HOOK
4	1	480371	HOOK, SWIVEL - 3 TON	9	3	360124	PIN, HITCH (HAIR PIN)
5	1	480372	BOLT, SHEAVE w/ ZERK	10	2	366063-100	DECAL, MAX. LOAD

**AW-366063**  
**TRAVELING BLOCK ASSEMBLY**  
**6006H (SHORT)**





## **AUTO CRANE COMPANY**

P. O. BOX 581510 • TULSA, OKLAHOMA 74158

# Limited Warranty

Auto Crane will warranty to consumer for a period of twelve months from date of purchase that each new Auto Crane product it sells will be free under normal use and service, from defects in material and workmanship. Date of purchase will be honored as either date of purchase by distributor or his date of sale of the product as substantiated by Distributor Delivery Report.

Obligation of Auto Crane under this warranty is limited to replacement or repair of parts that appear to manufacturer after review and / or inspection to be defective. This warranty does not obligate Auto Crane to bear the cost of labor or transportation charges in connection with the replacement or repair of defective parts. Responsibility for customer's claims arising from misapplication, abuse, misuse or alteration of equipment or parts lies with the distributor or user and no warranty obligation is assumed in the circumstances by Auto Crane.

Auto Crane will in no event be liable for any consequential damages or contingent liabilities arising out of the failure of any Auto Crane product or parts to operate properly.

Auto Crane makes no warranty in respect to component accessories, same being subject to the warranties of their respective manufacturers.

If field service, at the request of buyer, is rendered and fault is found not to be with Auto Crane's product, the buyer shall pay the time and expense of the field representative. Claims for service labor or other expenses that have been incurred by the buyer without approval or authorization of Auto Crane will not be accepted.

AUTO CRANE COMPANY IS UNDER NO OBLIGATION TO EXTEND THIS WARRANTY TO ANY CUSTOMER FOR WHICH AN AUTO CRANE WARRANTY REGISTRATION CARD HAS NOT BEEN COMPLETED AND MAILED TO AUTO CRANE COMPANY WITHIN FIFTEEN (15) DAYS AFTER DATE OF PURCHASE.