



ECONO-TON III/IR OWNERS MANUAL

Manual No. 999938

Rev. 9/2/2003

Serial No. _____

Mailing Address:
P.O. Box 580697
Tulsa, OK 74158-0697
Physical Address:
4707 N. Mingo Rd.
Tulsa, OK 74117-5904

Phone (918) 836-0463
Fax (918) 834-5979
<http://www.autocrane.com>



Auto Crane Warranty Registration

Fax Transmission

To: Warranty Department Fax: (918) 834-5979
 From: _____ Date: _____
 Re: Product Registration Pages: _____

End User Information: (Required for Warranty Activation)

Name: _____ Phone: _____
 Address: _____
 City: _____ State: _____ Zip: _____
 Contact: _____ E-mail Address: _____

Distributor Information: (Required for Warranty Activation)

Name: _____
 Address: _____
 City: _____ State: _____ Zip: _____
 Contact: _____ E-mail Address: _____

Product Information: (Required for Warranty Activation)

Model No.: _____ Serial No.: _____
 Date Product Delivered: _____ Date Processed:* _____
 VIN # _____ * For Auto Crane use only

ONE REGISTRATION FORM PER UNIT (CRANE OR BODY)

Registration form must be mailed or faxed within 15 days of customer installation.

Mail to:
 Warranty Department
 Auto Crane Company
 P.O. Box 581510
 Tulsa, OK 74158-0697

ECONO-TON II/IIR SERIES
OWNER'S MANUAL – REVISION RECORD

Revision Date	Section(s) Or Page(s)	Description of Change
09/02/03	Last page	New 2-year warranty policy to replace 1-year warranty policy

WARNINGS

WARNING! Federal law (49 cfr part 571) requires that the Final Stage Manufacturer of a vehicle certify that the vehicle complies with all applicable federal regulations. Any modifications performed on the vehicle prior to the final state are also considered intermediate stage manufacturing and must be certified as to compliance. The installer of this crane and body is considered one of the manufacturers of the vehicle. As such a manufacturer, the installer is responsible for compliance with all applicable federal and state regulations, and is required to certify that the vehicle is in compliance.

WARNING! It is the further responsibility of the installer to comply with the OSHA Truck Crane Stability Requirements as specified by 29 CFR part 1910.180 (C) (1).

WARNING! NEVER OPERATE THE CRANE NEAR ELECTRICAL POWER LINES!

Death or serious injury will result from boom, line, or load contacting electric lines. Do not use crane within 10 feet (3.05m) of electric power lines carrying up to 50,000 volts. One foot additional clearance is required for every additional 30,000 volts or less. **SEE DANGER DECAL (P/N 040529)** in this Owner's Manual.

WARNING! NEVER.....

- ◆ **EXCEED** load chart capacities (centerline of rotation to hoist hook).
- ◆ Un-reel last 5 wraps of cable from drum!
- ◆ Wrap cable around load!
- ◆ Attempt to lift or drag a load from the side! The boom can fail far below its rated capacity.
- ◆ Weld, modify, or use unauthorized components on any Auto Crane unit! This will void any warranty or liability. Also failure of the crane may result.
- ◆ Place a chain link on the tip of the hook and try to lift a load!
- ◆ Use a sling bar or anything larger than the hook throat that could prevent the hook latch from closing, thus negating the safety feature!
- ◆ Hold on any pendant Select Switch that will cause unsafe operating conditions!

WARNING! In using a hook with latch, **ALWAYS** make sure that the hook throat is closed before lifting a load! Proper attention and common sense applied to the use of the hoist hook and various slings will prevent possible damage to material being hoisted and may prevent injury to personnel.

WARNING! Failure to correctly plumb and wire crane can cause inadvertent operation and damage to crane and/or personnel!

WARNING! Auto Crane Company remote controlled cranes are not designed or intended to be used for any applications involving the lifting or moving of personnel.

WARNING! ALWAYS operate the crane in compliance with the load capacity chart. **DO NOT USE** the overload shutdown device to determine maximum rated loads, if the crane is equipped with this type of device.

READ THIS PAGE

TABLE OF CONTENTS

ECONO-TON II/IIR

INTRODUCTION	1-1
SAFETY TIPS AND PRECAUTIONS	2-1
OPERATING PRACTICES & WARNINGS	2-3
OPERATION OF UNIT / OUTRIGGERS	2-4
QUALIFICATIONS FOR OPERATORS	2-5
INSPECTION, TESTING, AND MAINTENANCE	2-8
SAFETY DECAL SECTION	3-1
GENERAL DIMENSIONS	3-7
MOUNTING AND INSTALLATION	3-9
LUBERCATION AND MAINTENCE SCHEDULE	3-14
GENERAL ASSEMBLY	4-1
HOIST ASSEMBLY	5-1
TRAVELING BLOCK ASSEMBLY	6-1
ELECTRICAL SCHEMATIC	7-1
PENDANT CONTROL ASSMEBLY	7-2
LOAD CHART	8-1
<u>ADDENDUM SECTION - ECONO-TON IIR</u>	
DECAL SECTION	9-1
GENERAL DIMENSIONS	10-1
GENERAL ASSEMBLY	11-1
ROTATION ASSEMBLY	12-1
HOIST ASSEMBLY	13-1
ELECTRICAL SCHEMATIC	14-1
PENDANT CONTROL ASSMEBLY	14-3
LOAD CHART	15-1
WARRANTY	LAST PAGE

INTRODUCTION

ECONO-TON II / IIR

Auto Crane products are designed to provide many years of safe, trouble-free, dependable service when properly used and maintained.

To assist you in obtaining the best service from your crane and to avoid untimely crane and/or vehicle failure, this manual provides the following operating and service instructions. It is **specifically recommended** that all operating and service personnel consider this manual as mandatory material for reading and study before operating or servicing Auto Crane products. It is **highly recommended** that crane owners, equipment managers and supervisors also read this manual.

Auto Crane has incorporated several safety features in the Econo-Ton II crane for your protection. The material and electrical systems were designed to minimize weight and lengthen durability.

For your convenience the overall dimensions of the Econo-Ton II crane are included on the General Dimension Drawing. Rotation and turning radius are also listed on that drawing.

Remember, the crane adds weight to the vehicle. Adding weight may change the driving and riding characteristics of the vehicle unless the appropriate overload spring(s) are installed on the truck. The payload of the vehicle is reduced by the weight of the crane. The operator should exercise care when loading the vehicle. Distributing the payload on the vehicle evenly will greatly improve the driving and riding characteristics of the vehicle.

Auto Crane Company issues a limited warranty certificate with each unit sold. See last page for warranty

The Econo-Ton II cranes are attached directly to your 12 volt truck electrical system. The power cable is included with the crane. The Econo-Ton II is another highly efficient Auto Crane product. The use of a maintenance-free battery is not recommended for use on any Auto Crane product. The recommended alternator and battery that will give the longest life with the most useful duty cycle is a 70 amp alternator with a 625 cold cranking amp battery. These specifications should be considered minimum.

It has always been Auto Crane Company policy to handle all warranty claims we receive as promptly as possible. If a warranty claim involves discrepant material or workmanship, Auto Crane will take immediate corrective action.

It is understandable that Auto Crane Company cannot assume responsibility of liability when it is obvious that our products have been abused, misused, overloaded or otherwise damaged by inexperienced persons trying to operate the equipment without reading the manual.

Auto Crane will not assume responsibility or liability for any modifications or changes made to unit, or installation of component parts done without authorization.

Auto Crane maintains a strong distributor network and a knowledgeable Customer Service Department. In most cases, an equipment problem is solved via phone conversation with our customer service department. The customer service department also has the ability to bring a local distributor, a regional sales manager, or a factory serviceman into the solution of an equipment problem. If, through no fault of Auto Crane Company, it is necessary to send an experienced factory serviceman on a field service call, the rates stated in the Auto Crane Distributor's Flat Rate Manual will apply.

Auto Crane Company's extensive Research and Development Program allow our customers to use the best equipment on the market. Our Engineering Staff and our knowledgeable sales people, are always available to our customers in solving crane and winch-type application problems. When in doubt, call the Auto Crane factory.

DISTRIBUTOR ASSISTANCE:

Should you require any assistance not given in this manual, we recommend that you consult your nearest Auto Crane Distributor. Our distributors sell authorized parts and have service departments that can solve almost any needed repair.

NOTE: THIS MANUAL SHOULD REMAIN WITH THE CRANE AT ALL TIMES.

This manual does not cover all maintenance, operating, or repair instructions pertinent to all possible situations. If you require additional information, please contact the **Auto Crane Company** at the following telephone number: **(918) 836-0463**. The information contained in the manual is in effect at the time of this printing. Auto Crane Company reserves the right to update this material without notice or obligation.

--- IMPORTANT ---
SAFETY TIPS AND PRECAUTIONS

1. No unqualified or unauthorized person shall be allowed to operate the crane.
2. **WARNING:** Never weld, modify, or use unauthorized components / parts on any Auto Crane unit. This will void any warranty or liability. Also, failure of the crane may result.
3. Make certain the vehicle meets minimum chassis requirements. (These requirements do not guarantee unit stability.)
4. Make certain the crane is installed per factory specifications. Contact your local distributor or the Auto Crane factory if any questions arise.
5. Visual inspections and tests should be conducted at the beginning of each shift each day to ensure that the crane and all its operating systems are in good condition and working order before it is used.
6. Inspect hydraulic hoses frequently for signs of deterioration, and replace them as required.
7. If a hydraulic break occurs, leave the area of the break and do not attempt to stop the break by hand as the hydraulic oil may be hot and under high pressure which can cause serious injury. Shut the system down as soon as possible.
8. Check the hook at least every thirty days for distortions or cracks and replace it as required.
9. Oil gears as required.
10. Stop all operations when cleaning, adjusting or lubricating the machine.
11. Keep dirt and grit out of moving parts by keeping a crane clean. Make sure machine is free of excess oil, grease, mud and rubbish, thus reducing accidents and fire hazards.
12. When a new cable is installed, operate first with a light load to let the cable adjust itself.
13. Locate the vehicle at the work site for the best stability possible.
14. Keep the vehicle in a level position while loading or unloading.
15. Observe operating area for obstructions and/or power lines that might be a hazard
16. **WARNING: NEVER OPERATE THE CRANE NEAR ELECTRICAL POWER LINES.** Auto Crane Company recommends that the crane never be any closer to a power line (including telephone lines) than 10 feet at any point.
17. Allow the vehicle engine to warm up before operating crane.
18. Know the weight of your rigging and load to avoid overloading the crane.
19. Deduct the weight of the load handling equipment from the load rating to determine how much weight can be lifted.
20. All load ratings are based on crane capacity, NOT the vehicle stability. Remember in lifting a heavy load, the weight can create enough tipping moment to overturn the vehicle
21. Always comply with load chart capacities, (centerline of rotation to hook).
22. Secure all loads before lifting.
23. Always set the emergency brake before beginning operation.
24. Keep objects and personnel clear of crane path during operation.
25. Operate control levers slowly and smoothly in order to meter oil flow for safe operation.
26. Always use outriggers from vehicle to the ground during crane operation. Ensure that they are firmly positioned on solid footings. Stand clear of outriggers while they are being extended.
27. If any outrigger, when extended, rests on a curb or other object that prevents it from extending to its maximum distance, shorten bearing or fulcrum point and reduce the maximum load accordingly.
28. When an outrigger will not reach the ground due to holes or grades, it shall be blocked up to provide level and firm support for the truck.
29. When working in soft earth, use wide pads under outrigger feet to prevent sinking.
30. Always store outriggers before transportation.

WARNING!

Auto Crane Company cranes are not designed or intended for use in lifting or moving persons. Any such use shall be considered to be improper and the seller shall not be responsible for any claims arising there from. This sale is made with the express understanding that there is no warranty that the goods shall be fit for the purpose of lifting or moving persons or other improper use and there is no implied warranty or responsibility for such purposes.

--- IMPORTANT ---

SAFETY TIPS AND PRECAUTIONS

31. Always store the crane in its stowed position for transportation.
32. Remember the overall height of the entire unit for garage door clearance or when moving under objects with low overhead clearance
33. Disengage power takeoff (PTO) before moving the vehicle.
34. Always walk around the vehicle before moving.
35. Never drive with a load suspended from crane.
36. Do not take your eyes off a moving load. Look in the direction you are moving.
37. Never swing a load over people.
38. Do not stop the load sharply in midair so that it swings like a pendulum. Meter the control levers to avoid this situation.
39. Crane boom length should be kept as short as possible for maximum lifting capacity and greater safety. Longer booms require additional care in accelerating and decelerating the swing motion, and thus slow down the working cycle and reduce productivity.
40. Keep the load directly and vertically under the boom point at all times. Crane booms are designed primarily to handle vertical loads, not side lifts.
WARNING: Never attempt to lift, drag, tow or pull a load from the side. The boom can fail far below its rated capacity.
41. Do not push down on anything with boom extensions, lift or outer boom function.
42. Do not lift personnel with any wire rope attachment or hook. There is no implied warranty or responsibility for such purposes.
43. **WARNING:** In using a safety hook, ALWAYS close the hook throat before lifting a load. Proper attention and common sense applied to the use of the hook and various slings will prevent possible damage to material being hoisted and may prevent injury to personnel.
44. **WARNING:** Never place a chain link on the tip of the hook and try to lift a load with the hoist.
45. **WARNING:** Never use a sling bar or anything larger than the hook throat which could prevent the safety latch from closing, thus negating the safety feature.
46. If the crane is equipped with an optional winch:
 - do NOT allow personnel to ride on loadline, hook, load, or any other device attached to winch line.
 - do NOT extend boom without reeling off line at the same time when using winch.
 - do pull load-block up against the boom tip.
47. Do not wrap the wire rope around sharp objects when using winch.
48. **WARNING:** Never unreel last 5 wraps of cable from drum.

--- IMPORTANT ---

OPERATING PRACTICES AND WARNINGS

1. Make certain the vehicle meets minimum chassis requirements. (These requirements do not guarantee unit stability)
2. Make certain the crane is installed per factory specifications. Contact your local Distributor or the Auto Crane factory if any questions arise.
3. Keep the vehicle in as level a position as possible while loading or unloading.
4. **ALWAYS** set the vehicle emergency brake before beginning crane operations.
5. **ALWAYS** use outriggers from vehicle to the ground during crane operation. Make sure they are firmly positioned on solid footings.
6. All load ratings are based on crane capacity, **NOT** truck/crane stability.
7. Keep objects and personnel clear of crane path during operation.
8. Keep hoist cable pulled tight at all times.
9. **REMEMBER**, in lifting a heavy load, the weight can create enough tipping momentum to overturn the vehicle.
10. **ALWAYS** keep load as close to ground as possible.
11. Hydraulic hoses need to be inspected frequently for signs of deterioration, and be replaced as required.
12. The hoist hook is an important item that an operator should consider and use properly. It should be checked on a daily basis for distortion or cracks.
13. **ALWAYS** store outriggers before road travel.
14. **WARNING! NEVER OPERATE THE CRANE NEAR ELECTRICAL POWER LINES!** Death or serious injury will result from boom, line, or load contacting electric lines. Do not use crane within 10 feet (3.05m) of electric power lines carrying up to 50,000 volts. One foot additional clearance is required for every additional 30,000 volts or less.
15. **WARNING! NEVER EXCEED** load chart capacities (centerline of rotation to hoist hook).
16. **WARNING! NEVER** un-reel last 5 wraps of cable from drum!
17. **WARNING! NEVER** wrap cable around load!
18. **WARNING! NEVER** attempt to lift or drag a load from the side! The boom can fail far below its rated capacity.
19. **WARNING! NEVER** weld, modify, or use unauthorized components on any Auto Crane unit! This will void any warranty or liability. Also failure of the crane may result.
20. **WARNING! NEVER** place a chain link on the tip of the hook and try to lift a load!
21. **WARNING! NEVER** use a sling bar or anything larger than the hook throat that could prevent the hook latch from closing, thus negating the safety feature!
22. **WARNING!** In using a hook with latch, **ALWAYS** insure that the hook throat is closed before lifting a load! Proper attention and common sense applied to the use of the hoist hook and various slings will prevent possible damage to material being hoisted and may prevent injury to personnel. Switch on that will cause unsafe operating conditions!
WARNING! NEVER hold any Control Select Switch on that will cause unsafe operating conditions!

WARNING!

Auto Crane Company remote controlled, stiff boom cranes are not designed or intended to be used for any applications involving the lifting or moving of personnel.

--- IMPORTANT ---

OPERATION OF UNIT

1. Make sure this manual has been thoroughly read by all crane operating personnel and supervisors.
2. A routine inspection of the crane should be mandatory before each operating day. Any defects should be corrected immediately.
3. At a job site the vehicle should be positioned so that the crane can adequately reach the load within the rated capacity (centerline of rotation to hoist hook).
4. Keep the vehicle as level as possible during operation.
5. For electric cranes, **engage emergency brake** and leave ignition on with transmission in neutral (or in park for automatic transmissions). Activate any crane power switches. For Auto Crane units requiring battery and hydraulic operation, **engage emergency brake**, place gear selector in neutral, press clutch, activate PTO, release clutch and after hydraulic fluid is warm, set throttle control to proper engine speed.
6. Always use outriggers from the truck to the ground. Be sure these are firm and adequately positioned. When rotating, **keep load as low to the ground as possible**.
7. Remove the transmitter from cab or storage area. Power transmitter on. Detach hook from dead man. Crane is now ready for operation.
8. Always boom up before rotating so the boom will clear the required boom support.
9. When extending the boom, always maintain clearance between the boom crown and the traveling block or hoist hook.
10. Always observe safe and practical operation to avoid possible accidents. Refer to Safety Tips and Precautions.
11. After completing lifting operations, return the boom to stowed position on the boom support. Avoid unneeded pressure on the boom support.
12. Store transmitter in proper location (in cab or storage area).
13. Return outriggers to stowed position. Make sure they are pinned in place or jacklegs are returned to compartment.
14. Check work area for any tools or equipment not stored.
15. Release throttle control, depress clutch and disengage PTO. Deactivate any crane power switches.
16. Report any unusual occurrence during crane operation that may indicate required maintenance or repair.
17. **NEVER** use two cranes to support a load too large for either crane.

OPERATION OF

OUTRIGGERS

For hydraulic outriggers:

1. Shift crane/outrigger control valve to "outrigger" position.
2. Operate the outrigger control valves (located on the outrigger cylinders) to position the outriggers.
3. After outriggers are positioned, return crane/outrigger selector to "crane" position.
4. Crane is now ready to operate.

For manual outriggers:

1. Pull lock pins to release jack leg or drop down outrigger and move to outermost lock position.
2. Make sure lock pins are reinstalled properly.
3. Lower outrigger pad to firm ground and adjust foot to take out slack.
4. Crane is now ready to operate.

QUALIFICATIONS FOR AND CONDUCT OF OPERATORS AND OPERATING PRACTICES

OPERATORS

1. **Crane operation shall be limited to personnel with the following minimum qualifications:**
 - A. Designated persons.
 - B. Trainees under the direct supervision of a designated person.
 - C. Maintenance and test personnel (when it is necessary in the performance of their duties).
 - D. Inspectors (crane).
2. **No one other than the personnel specified above shall enter the operating area of a crane with the exception of persons such as oilers, supervisors, and those specified persons authorized by supervisors whose duties require them to do so and then only in the performance of their duties and with the knowledge of the operator or other persons.**

QUALIFICATIONS FOR OPERATORS

3. **Operators shall be required by the employer to pass a practical operating examination. Qualifications shall be limited to the specific type of equipment for which examined.**
4. **Operators and operator trainees shall meet the following physical qualifications:**
 - A. Vision of at least 20/30 Snellen in one eye and 20/50 in the other, with or without corrective lenses.
 - B. Ability to distinguish colors, regardless of position, if colors differentiation is required for operation.
 - C. Adequate hearing with or without hearing aid for the specific operation.
5. **Evidence of physical defects or emotional instability which render a hazard to operator or others, which in the opinion of the examiner could interfere with the operator's performance may be sufficient cause for disqualification. In such cases, specialized clinical or medical judgment and tests may be required.**
6. **Evidence that the operator is subject to seizures or loss of physical control shall be sufficient reason for disqualification. Specialized medical tests may be required to determine these conditions.**
7. **Operators and operator trainees should have normal depth perception, coordination, and no**

- tendencies to dizziness or similar undesirable characteristics.
8. **In addition to the above listed requirements, the operator shall:**
 - A. Demonstrate the ability to comprehend and interpret all labels, operator's manuals, safety codes and other information pertinent to correct crane operations.
 - B. Possess knowledge of emergency procedures and implementation of same.
 - C. Demonstrate to the employer the ability to operate the specific type of equipment.
 - D. Be familiar with the applicable safety regulations.
 - E. Understand responsibility for maintenance requirements of crane.
 - F. Be thoroughly familiar with the crane and its control functions.
 - G. Understand the operating procedures as outlined by the manufacturer.

CONDUCT OF OPERATORS

9. **The operator shall not engage in any practice, which will divert his attention while actually operating the crane.**
10. **Each operator shall be responsible for those operations under the operator's direct control. Whenever there is any doubt as to safety, the operator shall consult with the supervisor before handling the loads.**
11. **The operator should not leave a suspended load unattended unless specific precautions have been instituted and are in place.**
12. **If there is a warning sign on the switch or engine starting controls, the operator shall not close the switch or start the engine until the warning sign has been removed by the appointed person.**
13. **Before closing the switch or starting the engine, the operator shall see that all controls are in the "OFF" or neutral position and all personnel are in the clear.**
14. **If power fails during operation, the operator shall:**
 - A. move power controls to the "OFF" or neutral position.
 - B. land the suspended load and boom, if practical.

QUALIFICATIONS FOR AND CONDUCT OF OPERATORS AND OPERATING PRACTICES

15. The operator shall be familiar with the equipment and its proper care. If adjustments or repairs are necessary, the operator shall report the same promptly to the appointed person, and shall also notify the next operator.
16. All controls shall be tested by the operator at the start of each shift. If any controls do not operate properly, they shall be adjusted or repaired before operations are begun
17. Stabilizers shall be visible to the operator while extending or setting unless operator is assisted by a signal person.

OPERATING PRACTICES

HANDLING THE LOAD

18. Size of load

- A. No crane shall be loaded beyond the rated load except for test purposes.
- B. The load to be lifted is to be within the rated load of the crane and its existing configuration.
- C. When loads which are not accurately known are to be lifted, the person responsible for the job shall ascertain that the weight of the load does not exceed the crane rated load at the radius at which the load is to be lifted.

19. Attaching the load

- A. The load shall be attached to the hook by means of slings or other devices of sufficient capacity.
- B. Hoist rope shall not be wrapped around the load.

20. Moving the load

- A. The operator shall determine that:
- B. The crane is level and, where necessary, the vehicle/carrier is blocked properly.
- C. The load is well secured and balanced in the sling or lifting device before it is lifted more than a few inches.
- D. Means are provided to hold the vehicle stationary while operating the crane.
- E. Before starting to lift, the hook shall be brought over the load in such a manner as to minimize swinging.
- F. During lifting care shall be taken that:

1. There is no sudden acceleration or deceleration of the moving load.
2. Load, boom or other parts of the crane do not contact any obstruction.

G. Cranes shall not be used for dragging loads sideways.

H. This standard recognizes that articulating boom cranes are designed and intended for handling materials. They do not meet personnel lift or elevator requirements. Therefore, no lifting, lowering, swinging or traveling shall be done while a person is on the hook or load. Hook attached suspended work platforms (baskets) shall not be used with cranes covered by this standard. Work platforms attached to the boom must be approved by crane manufacturer.

I. The operator should avoid carrying loads over people.

J. When the crane is so equipped, the stabilizers shall be fully extended and set. Blocking under stabilizers shall meet the requirements as follows:

1. Strong enough to prevent crushing.
2. Of such thickness, width and length as to completely support the stabilizer pad.

K. Firm footing under all tires, or individual stabilizer pads should be level. Where such a footing is not otherwise supplied, it should be provided by timbers, cribbing, or other structural members to distribute the load so as to not exceed allowable bearing capacity or the underlying material.

L. In transit, the boom shall be carried in stowed position.

M. When rotating the crane, sudden starts and stops shall be avoided. rotational speed shall be such that the load does not swing out beyond the radius at which it can be controlled.

N. The crane shall not be transported with a load on the hook unless recommended by the manufacturer.

O. No person should be permitted to stand or pass under a suspended load.

21. Stowing procedure. Follow the manufacturer's procedure and sequence when stowing and unstowing the crane

QUALIFICATIONS FOR AND CONDUCT OF OPERATORS AND OPERATING PRACTICES

MISCELLANEOUS

OPERATING NEAR ELECTRICAL POWER LINES

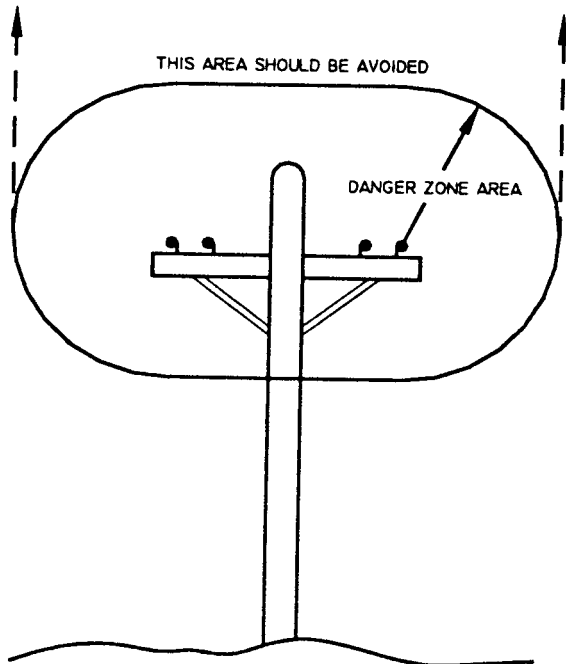

22. Cranes shall be operated so that no part of the crane or load enters into the danger zone shown above.

EXCEPTIONS

- A. The danger zone may be entered after confirmation by an appointed person that the electrical distribution and transmission lines have been de-energized and visibly grounded at the point of work; or
- B. The danger zone may be entered if insulating barriers (not a part of nor an attachment to the crane) have been erected to prevent physical contact with the lines.

23. For lines rated 50 kV or below, minimum clearance between the lines and any part of the crane or load (including handling appendages) shall be 10-ft. (3m). For higher voltages, see Table 1.

24. Caution shall be exercised when working near overhead lines, because they can move horizontally or vertically due to wind, moving the danger zone to new positions.

25. In transit with no load and boom lowered the clearance shall be specified in Table 1.

26. A qualified signalperson shall be assigned to observe the clearance and give warning before approaching the above limits.

- A. Any overhead wire shall be considered to be an energized line unless and until the person owning such line or the electrical utility authorities verify that it is not an energized line.
- B. Exceptions to this procedure, if approved by the administrative or regulatory authority if the alternate procedure provides equivalent protection and set forth in writing.
- C. Durable signs shall be installed at the operator's station and on the outside of the crane, warning that electrocution or serious bodily injury may occur unless a minimum clearance of 10 ft. (3.0m) between the crane or the load being handled and energized power lines. Greater clearances are required because of higher voltage as stated above. These signs shall be revised but not removed when local jurisdiction requires greater clearances.

TABLE 1

normal voltage, kV (phase to phase)		minimum required clearance	
		ft	(m)
<u>when operating near high voltage power lines</u>			
over	to 50	10	(3.50)
over	50 to 200	15	(4.6)
over	200 to 350	20	(6.1)
over	350 to 500	25	(7.62)
over	500 to 750	35	(10.67)
over	750 to 1000	45	(13.72)
<u>while in transit with no load and boom lowered</u>			
over	to 0.75	4	(1.22)
over	0.75 to 50	6	(1.83)
over	50 to 345	10	(3.83)
over	345 to 750	16	(4.87)
over	750 to 1000	20	(6.1)

INSPECTION, TESTING AND MAINTENANCE GENERAL

INSPECTION CLASSIFICATION

1. **Initial inspection. Prior to initial use, all new, altered, modified or extensively repaired cranes shall be inspected by a designated person to insure compliance with provisions of this standard.**
2. **Regular inspection. Inspection procedure for cranes in regular service is divided into two general classifications based upon the intervals at which inspection should be performed. The intervals in turn are dependent upon the nature of the components of the crane and the degree of their exposure to wear, deterioration, or malfunction. The two general classifications are herein designated as "frequent" and "periodic" with respective intervals between inspections as defined below.**
 - A. frequent inspection - daily to monthly intervals
 - B. periodic inspection - one to twelve intervals or as specifically recommended by the manufacturer

FREQUENT INSPECTION

3. **Inspection shall be performed by designated personnel.**
 - A. control mechanisms for maladjustment interfering with proper operation - daily, when used
 - B. control mechanisms for excessive wear of components and contamination by lubricants or other foreign matter
 - C. safety devices for malfunction
 - D. all hydraulic hoses, particularly those which flex in normal operation of crane functions, should be visually inspected once every working day, when used
 - E. hooks and latches for deformation, chemical damage, cracks, and wear. Refer to ANSI/ASME B30.10
 - F. rope reeving for compliance with crane manufacturer's specifications, if optional winch is used

- G. electrical apparatus for malfunctioning, signs of excessive deterioration, dirt and moisture accumulation
- H. hydraulic system for proper oil level and leaks daily
- I. tires for recommended inflation pressure, cuts and loose wheel nuts
- J. connecting pins and locking device for wear and damage

PERIODIC INSPECTION

4. **Deformed, cracked or corroded members in the crane structure and carrier**
5. **Loose bolts, particularly mounting bolts.**
6. **Cracked or worn sheaves and drums.**
7. **Worn, cracked, or distorted parts such as pins, bearings, shafts, gears, rollers and devices.**
8. **Excessive wear on brake and clutch system parts and lining.**
9. **Crane hooks inspected for cracks.**
10. **Travel steering, braking, and locking devices, for malfunction.**
11. **Excessively worn or damaged tires.**
12. **Hydraulic and pneumatic hose, fittings, and tubing inspection.**
 - A. evidence of leakage at the surface of the flexible hose or its junction with metal and coupling
 - B. A. blistering, or abnormal deformation to the outer covering of the hydraulic or pneumatic hose
 - C. A. leakage at threaded or clamped joints that cannot be eliminated by normal tightening or recommended procedures
 - D. A. evidence or excessive abrasion or scrubbing on the outer surface of a hose, rigid tube, or fitting. Means shall be taken to eliminate the interference of elements in contact or otherwise protect the components

INSPECTION, TESTING AND MAINTENANCE GENERAL

13. Hydraulic and pneumatic pumps and motors inspection.

- A. loose bolts or fasteners
- B. leaks at joints between sections
- C. shaft seal leaks
- D. unusual noises or vibrations
- E. loss of operating speed
- F. excessive heating of the fluid
- G. loss of pressure

14. Hydraulic and pneumatic valves inspection

- A. cracks in valve housing
- B. improper return of spool to neutral position
- C. leaks at spools or joints
- D. sticking spools
- E. failure of relief valves to attain or maintain correct pressure setting
- F. relief valve pressure shall be checked as specified by the manufacturers

15. Hydraulic and pneumatic cylinders inspection.

- A. drifting caused by fluid leaking across piston
- B. rod seals leaking
- C. leaks at welding joints
- D. scored, nicked, or dented cylinder rods
- E. damaged case (barrel)
- F. loose or deformed rod eyes or connecting joints

16. Hydraulic filters. Evidence of rubber particles on the filter elements may indicate hose, "O" ring, or other rubber component deterioration. Metal chips or pieces on the filter may denote failure in pumps, motors, or cylinders. Further checking will be necessary to determine origin of the problem before corrective action can be taken.

17. Labels are to be in place and legible.

CRANES NOT IN REGULAR USE

18. A crane which has been idle for a period of over one month or more, but not less than six months, shall be given an inspection conforming with the initial-regular- frequent inspections

19. A crane which has been idle for a period of over six months shall be given a complete inspection conforming with the initial-regular-frequent inspection requirements.

INSPECTION RECORDS

20. Dated records for periodic inspection should be made on critical items such as brakes, crane hooks, rope, hydraulic and pneumatic cylinders, and hydraulic and pneumatic relief pressure valves. Records should be kept available to an appointed person.

OPERATIONAL TESTS

21. Prior to initial use, all new, altered, modified, or extensively repaired cranes shall be tested for compliance with the operational requirements of this section, including functions such as the following:

- A. load lifting and lowering mechanisms
- B. boom lifting and lowering mechanisms
- C. boom extension and retraction mechanisms
- D. swing mechanisms
- E. safety devices
- F. operating controls comply with appropriate function labels

Operational crane test results shall be made available to an appointed person.

RATED TEST LOAD

Prior to initial use, altered, modified, or extensively repaired cranes shall be load tested by or under the direction of an appointed person.

INSPECTION, TESTING AND MAINTENANCE GENERAL

22. Test loads shall not exceed 110% of the manufacturer's load ratings.
23. Written reports shall be maintained showing test procedures and confirming the adequacy of repairs.

MAINTENANCE

PREVENTIVE MAINTENANCE

24. Before adjustment and repairs are started on a crane, the following precautions shall be taken as applicable:
- crane placed where it will cause the least interference with other equipment or operations
 - all controls at the "off" position
 - starting means rendered inoperative
 - boom lowered to the ground if possible or otherwise secured against dropping
 - relieve hydraulic oil pressure from all hydraulic circuits before loosening or removing hydraulic components
25. Warning or "OUT OF ORDER" signs shall be placed on the crane controls.
26. After adjustments and repairs have been made, the crane shall not be returned to service until all guards have been reinstalled, trapped air removed from hydraulic system (if required), safety devices reactivated, and maintenance equipment removed.

ADJUSTMENTS AND REPAIRS

27. Any hazardous conditions disclosed by the inspection requirements shall be corrected before operation of crane is resumed, Adjustments and repairs shall be done only by designated personnel.
28. Adjustments shall be maintained to assure correct functioning of components, The following are examples:
- functional operating mechanism
 - safety devices
 - control systems

29. Repairs or replacements shall be provided as needed for operation.

The following are examples:

- critical parts of functional operating mechanisms which are cracked, broken, corroded, bent, or excessively worn
 - critical parts of the crane structure which are cracked, bent, broken, or excessively corroded
 - crane hooks showing cracks, damage, or corrosion shall be taken out of service. Repairs by welding are not recommended
30. Instructions shall be provided by the manufacturer for the removal of air from hydraulic circuits.

LUBRICATION

All moving parts of the crane, for which lubrication is specified, should be regularly lubricated per the manufacturer's recommendations and procedures.

ROPE INSPECTION

31. Frequent Inspection
- All running ropes in service should be visually inspected once each working day. A visual inspection shall consist of observation of all rope which can be in use during the days operations. These visual observations should be considered with discovering gross damage such as listed below, which may be an immediate hazard.
 - distortion of the rope such as kinking, crushing, un-stranding, birdcaging, main strand displacement, or core protrusion. Loss of rope diameter in a short length or unevenness of outer strands should be replaced
 - general corrosion
 - broken or cut strands;
 - number, distribution and type of visible broken wires. When such damage is discovered, the rope shall either be removed from service or given as inspection.

INSPECTION, TESTING AND MAINTENANCE GENERAL

- B. Care shall be taken when inspecting sections of rapid deterioration such as flange points, crossover points, and repetitive pickup points on drums.

32. Periodic inspection

- A. The inspection frequency shall be determined by a qualified person and shall be based on such factors as
 1. expected rope life as determined by experience on the particular installation or similar installations
 2. severity of environment
 3. percentage of capacity lifts
 4. frequency rates of operation
 5. exposure to shock loads

Inspection need not be at equal calendar intervals and should be more frequent as the rope approaches the end of it's service life. This inspection shall be made at least annually.

- B. Periodic inspection shall be performed by a designated person. This inspection shall cover the entire length of the rope. Only the surface wires need be inspected. No attempt should be made to open the rope. Any deterioration results in appreciable loss of original strength, such as described below, shall be noted and determination made as to whether use of the rope would constitute a hazard: points listed above reduction of rope diameter below nominal diameter due to loss of core support, internal or external corrosion, or wear of outside wires; severely corroded, cracked, bent, worn or improperly applied connections;
- C. Care shall be taken when inspecting sections subject to rapid deterioration such as the following:
 1. sections in contact with saddles, equalizer sheaves, or other sheaves where rope travel is limited
 2. sections of the rope at or near terminal ends where corroded or broken wires may protrude

ROPE REPLACEMENT

- 33. **No precise rules can be given for determination of the exact time for replacement of rope, since many variable factors are involved.**

Continued use in this respect depends upon good judgement by a designated person in evaluating remaining strength in a used rope after allowance for deterioration disclosed by inspection. Continued rope operation depends upon this remaining strength.

- 34. **Conditions such as the following shall be reason for questioning continued use of the rope or increasing the frequency of inspection:**
 - A. in running ropes, six randomly distributed broken wires in one lay or three broken wires in one strand in one lay
 - B. one outer wire broken at the contact point with the core of the rope structure and protrudes or loops out of the rope structure. Additional inspection of this section is required
 - C. wear of one third of the original diameter of the outside individual wire
 - D. kinking, crushing, birdcaging, or any other damage resulting in distortion of the rope structure
 - E. evidence of any heat damage from any cause
 - F. reduction from nominal diameter of more than 1/64 in. (0.4mm) for diameters up to and including 5/16 in. (8 mm), 1/32 in. (0.8 mm) for diameter 3/8 in. (9.5 mm) to and including 1/2 in. (13 mm), 3/64 in. (1.2 mm) for diameter 9/16 in. (14.5 mm) to and including 3/4 in. (19 mm), 1/16 in. (1.6 mm) for diameter 7/8 in. (22 mm) to and including 1 1/8 in. (29 mm), 3/32 in. (2.4 mm) for diameters 1 1/4 in. (32 mm) to and including 1 1/2 in. (38 mm)
 - G. In standing ropes, more than two broken wires in one lay in sections beyond end connections or more than one broken wire at an end connection.

INSPECTION, TESTING AND MAINTENANCE GENERAL

- H. Replacement rope shall have a strength rating at least as great as the original rope furnished or recommended by the crane manufacturer. Any deviation from the original size, grade, or construction shall be specified by a rope manufacturer, or a qualified person.
35. **Rope not in regular use:** all rope which has been idle for a period of a month or more due to shutdown or storage of a crane on which it is installed, shall be given an inspection in accordance with above information before it is placed in service. This inspection shall be for all types of deterioration and shall be performed by a qualified person.
36. **Inspection records**
- A. A. frequent inspection- no records required
 - B. A. periodic inspections- in order to establish data as a basis for judging the proper time for replacement, a dated report condition at each periodic inspection should be kept on file. This report shall cover points of deterioration listed above.
- ROPE MAINTENANCE**
37. Rope should be stored to prevent damage or deterioration.
38. Unreeling or uncoiling of rope shall be done as recommended by the rope manufacturer and with care to avoid kinking or inducing twist.
39. Before cutting a rope, seizing shall be placed on each side of the place where the rope is to be cut to prevent unlaying of the strands. On pre-formed rope, one seizing on each side of the cut is required. On non-preformed ropes of 7/8 in. (22 mm) diameter or smaller, two seizings on each side of the cut are required, and for non-preformed rope 1 in. (25 mm) diameter or larger, three seizings on each side of the cut are required.
40. During installation care should be exercised to avoid dragging of the rope in the dirt or around objects which will scrape, nick crush or induce sharp bends in it.
41. Rope should be maintained in a well-lubricated condition. It is important that lubricant applied as a part of a maintenance program shall be compatible with the original lubricant and to this end the rope manufacturer should be consulted. Lubricant applied shall be the type which does not hinder visual inspection. Those sections of rope which are located over sheaves or otherwise hidden during inspection and maintenance procedures require special attention when lubricating rope. The object of rope lubrication is to reduce internal friction and to prevent corrosion.
42. When an operating rope shows greater wear or well defined localized areas than on the remainder of the rope, rope life can be extended in cases where a section at the worn end, and thus shifting the wear to different areas of the rope.

MAINTENANCE OF BATTERIES

Maintenance of Auto Crane unit batteries differs very little from the generally prescribed maintenance of any lead acid battery. All batteries must be kept *properly charged, properly filled with water, and relatively clean.*

Keep Properly Charged

Many things affect the proper charge to a battery, such as:

- 1 Regulator settings
- 2 Proper tightness of belts on the alternator or generator
- 3 Good, clean connections of all cables and wires at the following places:
 - A. Battery
 - B. Regulator
 - C. Starting motor
 - D. Alternator or generator
 - E. Ground connections (most important)

It is of extreme importance to keep the battery as fully charged as possible without overcharging, especially when vehicles are left outside for extended periods in extremely cold climates. A battery *can* freeze. Freezing points for various specific gravities of acid are as follows:

Specific Gravity (Corrected to 80°F)	Freezing Temp. Degrees F.
1.280	-90°F
1.250	-62°F
1.200	-16°F
1.150	5°F
1.100	19°F

As shown, a half-charged battery (about 1.200 specific gravity) cannot stand for any length of time at 20°F or it will freeze.

The *main reason* for keeping the battery as fully charged as possible without over-charging is to ensure that power is available even though the vehicle has been standing for some time.

Keep Properly Filled with Water

The battery should *always* be properly filled with water. If the electrolyte level is allowed to fall below the top of the plates, the results become threefold:

- 1 The exposed portion of the plate will become sulfated.
- 2 The portion of the plate exposed is not usable.
- 3 That portion of the acid remaining becomes more concentrated and may cause more rapid deterioration of the remaining parts of the battery.

Keep A Relatively Clean Battery

The battery should be kept clean. Batteries filled with acid and which are not in use self-discharge to a limited degree because of the nature of the materials within the battery. If dirt is allowed to collect on the top of the battery (and this dirt absorbs moisture) and electrical path can be set up between the various terminals of the battery and the ground. Once such a path has been established, the self-discharge of the battery is accelerated. This also accelerates corrosion of the battery cables at the terminals.

Periodic Maintenance is Needed

A definite program of periodic maintenance of all batteries should be conducted on a regular basis. Periodic maintenance includes:

- 1 Checking belts for tightness on the charging equipment
- 2 Checking battery electrolyte levels
- 3 Checking cables for good connections
- 4 Cleaning where corrosion is apparent

When corrosion is cleaned off, the cable terminals and battery terminals should be coated with a light coating of petroleum jelly before they are replaced. When terminals are cleaned, the top of the battery should be cleaned with a mild solution of soda water.

MAINTENANCE OF BATTERIES

Low Maintenance Batteries (Maintenance Free)

Low maintenance batteries should not be used on Auto Cranes or trucks equipped with Auto Cranes. The batteries are not designed for "deep" discharge.

Testing Your Battery

If the condition of the battery is in question, it should be removed from the vehicle, taken to the shop, and allowed to reach room temperature. It should then be recharged until specific gravity readings taken at one-half hour intervals. If the specific gravity readings are fairly uniform, the battery should be checked with a high rate tester. Use the tester in accordance with the manufacturer's instructions. The high rate tester is the best method to test a questionable battery.

If, after charging, it is noted that the specific gravity reading of one cell is 30 points less than any of the other cells, it may be assumed that the cell is bad and that the battery should be replaced. If all cells are uniform but not up to full charge, a low rate of charge should be attempted for an extended time. This usually will recover a badly sulfated battery.

Replacing a Battery

If it is necessary to replace a battery, and a dry charge battery is used, the following procedure applies:

- 1 Fill the battery with electrolyte of the proper specific gravity.
- 2 Place the battery on charge according to the manufacturer's instructions.

It is essential that the second step above be followed to ensure that the battery going on the vehicle is fully charged.

It is also very important that the battery hold-downs be checked periodically to ensure that the batteries are properly positioned to avoid vibration problems, breakage of cables or terminals. Care must be taken to avoid cracking or breaking containers or covers by tightening hold-down fixtures excessively. They also must not be so loose that breakage results from a hold-down that is too loose.

SAFETY DECAL SECTION

ECONO-TON II

PART NO.: 40579000
 DECAL: OPERATING INSTRUCTIONS
 FUNCTION: To inform the operator of the proper procedure to follow for safe operation of the crane.
 USED ON: All Cranes
 QUANTITY: 2
 PLACEMENT: Pedestal, Back Side

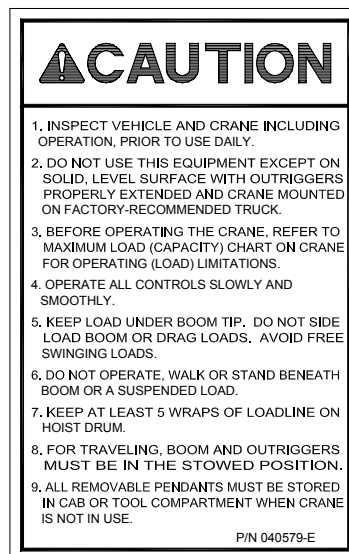

PART NO.: 040580000
 DECAL: OPERATING TRAINING
 FUNCTION: To inform the operator of the need to receive proper training before using the crane.
 USED ON: All Cranes
 QUANTITY: 2
 PLACEMENT: Pedestal, Back Side

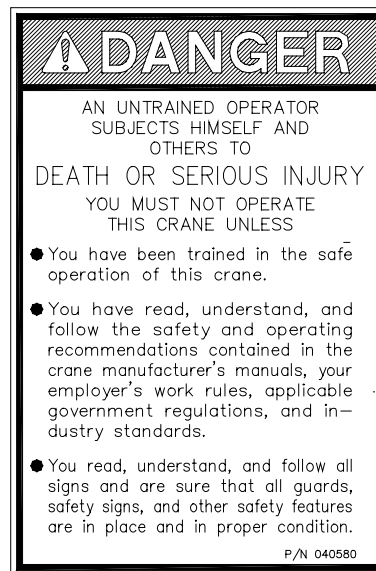

PART NO.: 040517000
 DECAL: STAY CLEAR OF BOOM
 FUNCTION: To inform the operator of the hazard of proximity or contact with the crane boom during operation.
 USED ON: All Cranes
 QUANTITY: 2
 PLACEMENT: Both sides of crown



SAFETY DECAL SECTION

ECONO-TON II

PART NO.: 040630000
 DECAL: STAY CLEAR OF LOAD
 FUNCTION: To inform the operator of the hazard of proximity or contact with the crane load during operation.
 USED ON: All Cranes
 QUANTITY: 2
 PLACEMENT: Both sides of Traveling Block

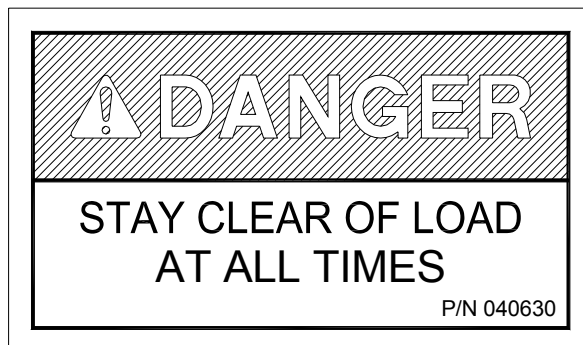

PART NO.: 370495
 DECAL: OPERATING INSTRUCTIONS
 FUNCTION: To inform the operator of the proper procedure to follow for safe operation of the crane.
 USED ON: Short Pedestal Cranes
 QUANTITY: 2
 PLACEMENT: Both Sides of Boom

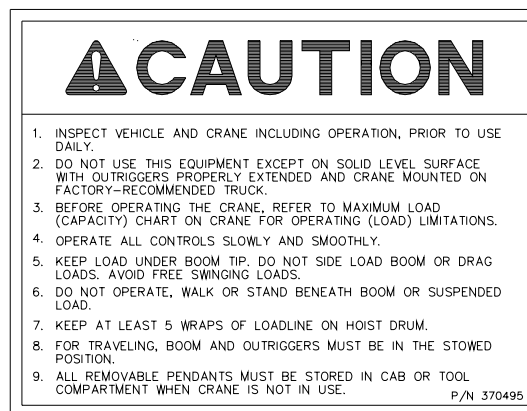

PART NO.: 370496
 DECAL: OPERATING TRAINING
 FUNCTION: To inform the operator of the need to receive proper training before using the crane.
 USED ON: Short Pedestal Cranes
 QUANTITY: 2
 PLACEMENT: Both Sides of Boom

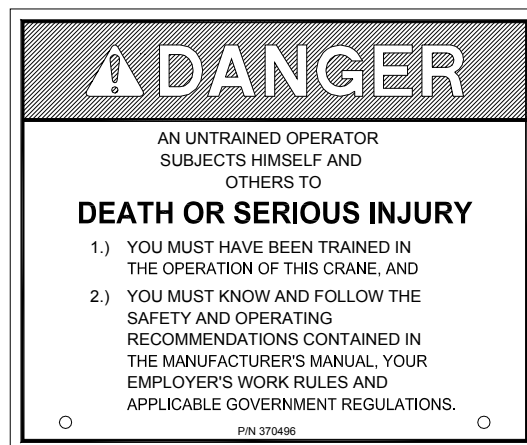

DECAL KIT - ECONO-TON II

P/N: 370065000 – 5' BOOM

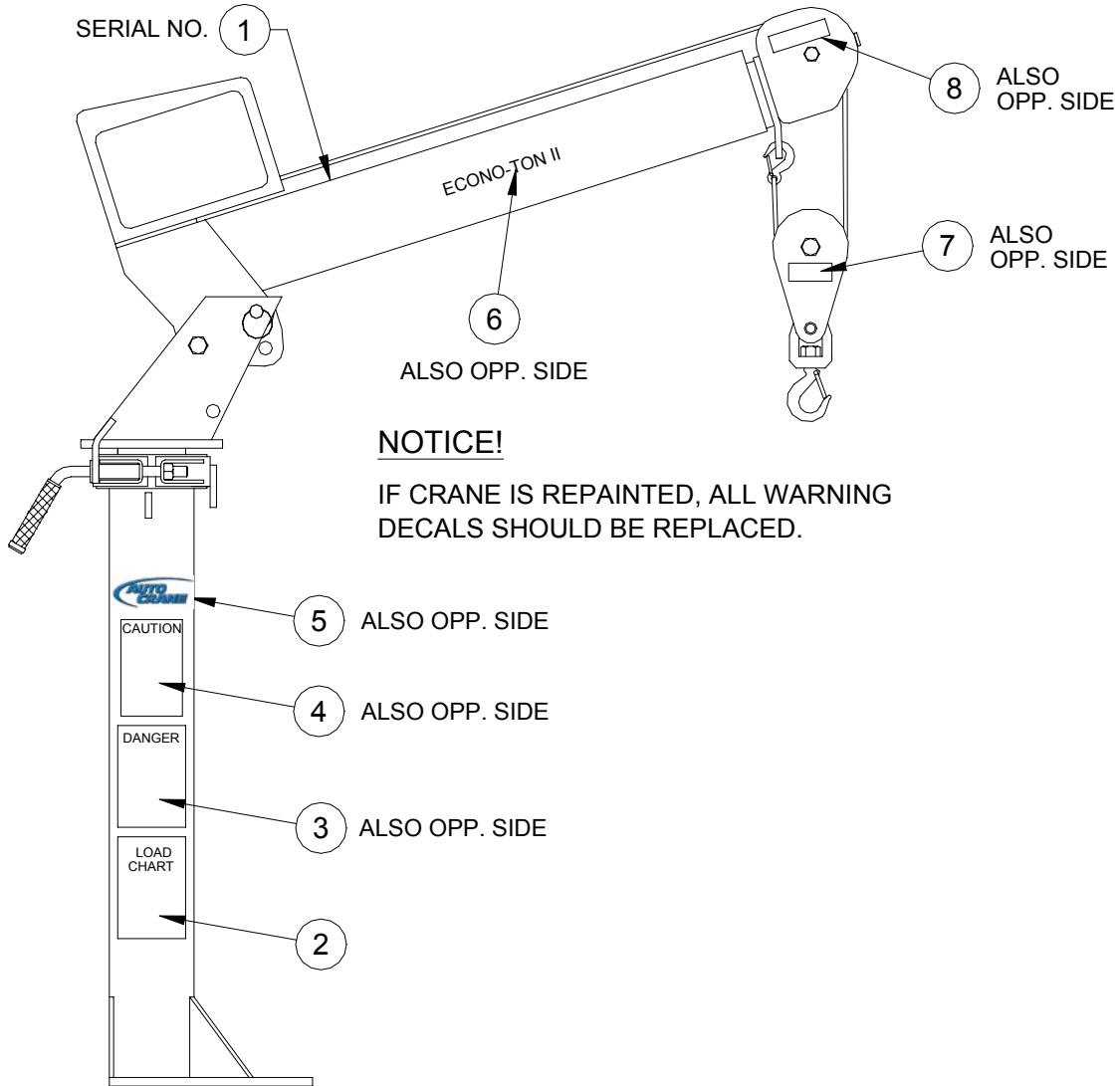

ITEM NO.	QTY.	PART NO.	DESCRIPTION
1	1	330622	DECAL, SERIAL NO.
2	1	370053	DECAL, LOAD CHART
3	2	040580	DECAL, DANGER
4	2	040579	DECAL, CAUTION
5	2	040619	DECAL, AUTO CRANE
6	2	370018	DECAL, ECONO-TON II
7	2	040630	DECAL, DANGER
8	2	040517	DECAL, DANGER STAY CLEAR OF BOOM

DECAL KIT - ECONO-TON II

P/N: 370066000 - 7' BOOM

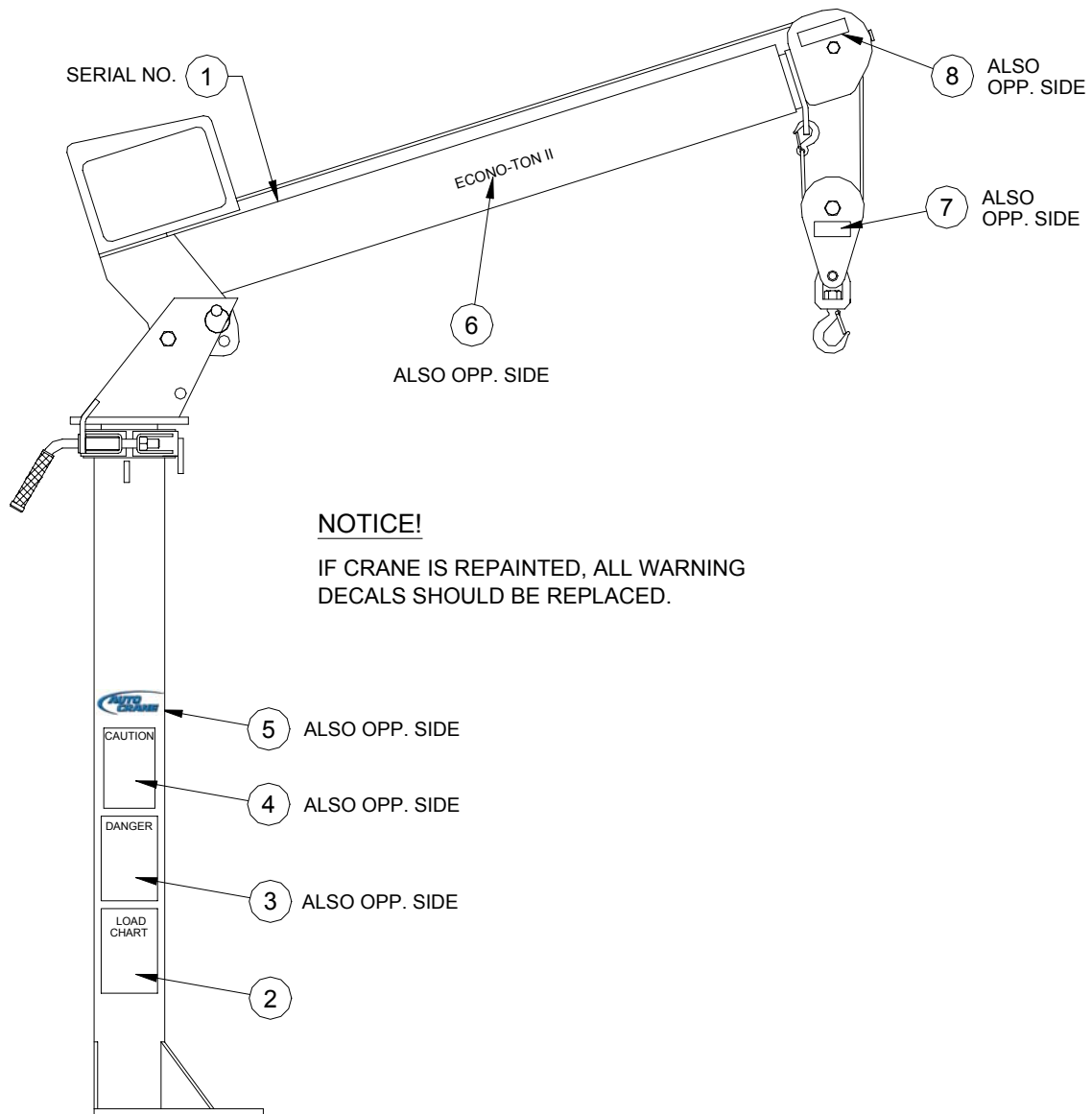

ITEM NO.	QTY.	PART NO.	DESCRIPTION
1	1	330622	DECAL, SERIAL NO.
2	1	370054	DECAL, LOAD CHART
3	2	040580	DECAL, DANGER
4	2	040579	DECAL, CAUTION
5	2	040619	DECAL, AUTO CRANE
6	2	370018	DECAL, ECONO-TON II
7	2	040630	DECAL, DANGER
8	2	040517	DECAL, DANGER STAY CLEAR OF BOOM

DECAL KIT - ECONO-TON II

P/N: 370065001 – 5' BOOM

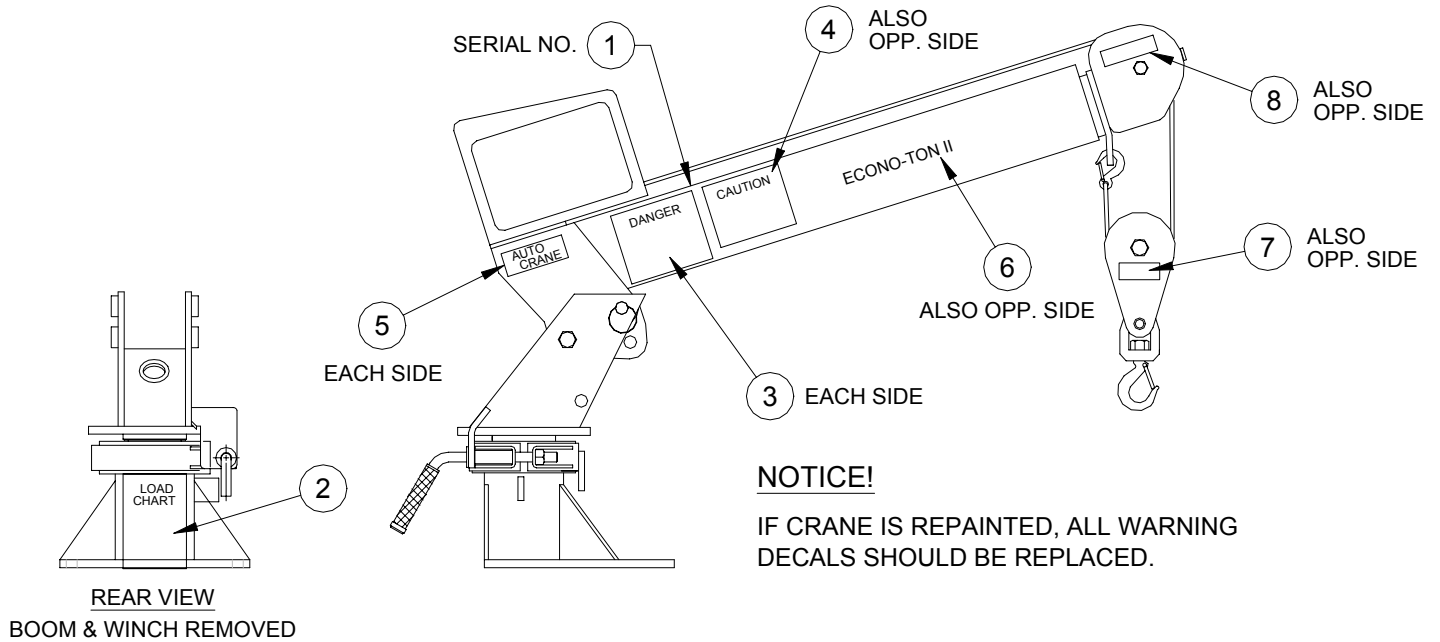

ITEM NO.	QTY.	PART NO.	DESCRIPTION
1	1	330622	DECAL, SERIAL NO.
2	1	370053	DECAL, LOAD CHART
3	2	370496	DECAL, DANGER
4	2	370495	DECAL, CAUTION
5	2	040619	DECAL, AUTO CRANE
6	2	370018	DECAL, ECONO-TON II
7	2	040630	DECAL, DANGER
8	2	040517	DECAL, DANGER STAY CLEAR OF BOOM

DECAL KIT - ECONO-TON II

P/N: 370066001 - 7' BOOM

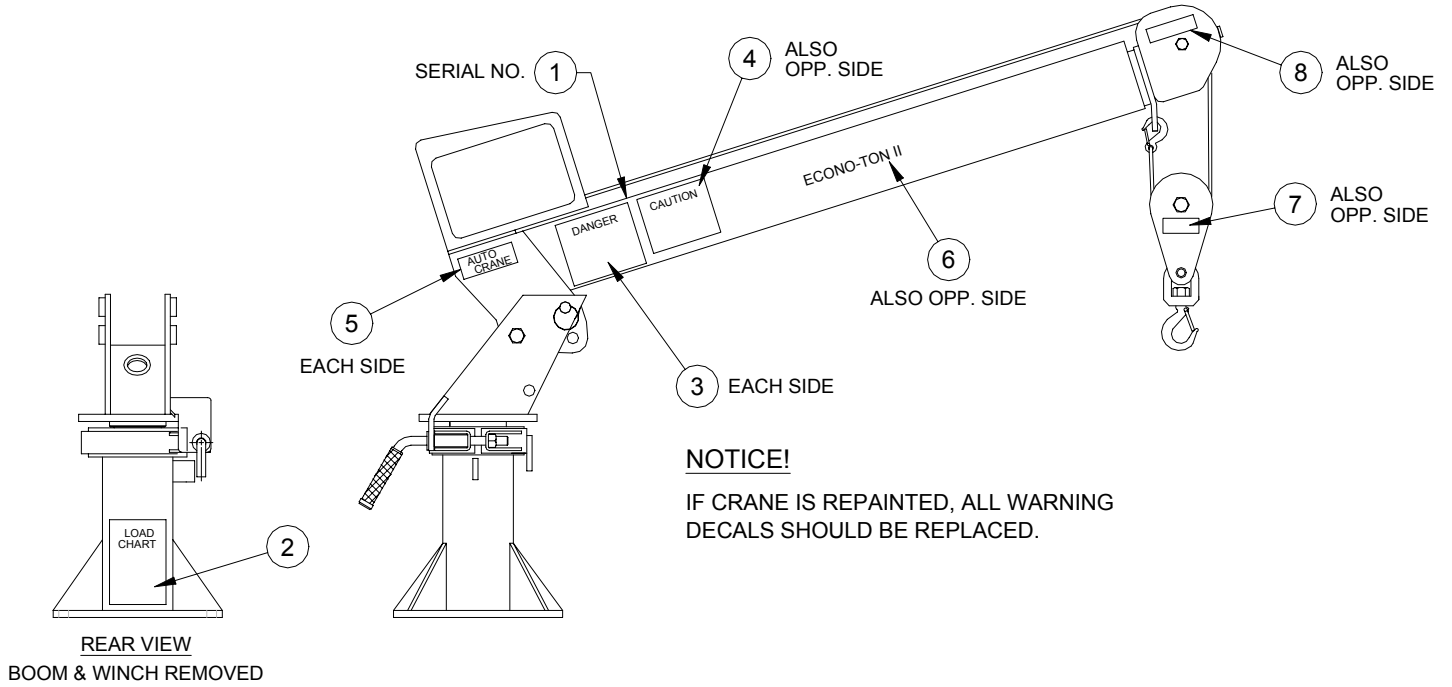

ITEM NO.	QTY.	PART NO.	DESCRIPTION
1	1	330622	DECAL, SERIAL NO.
2	1	370054	DECAL, LOAD CHART
3	2	370496	DECAL, DANGER
4	2	370495	DECAL, CAUTION
5	2	040619	DECAL, AUTO CRANE
6	2	370018	DECAL, ECONO-TON II
7	2	040630	DECAL, DANGER
8	2	040517	DECAL, DANGER STAY CLEAR OF BOOM

GENERAL DIMENSIONS ECONO-TON II – 5' BOOM

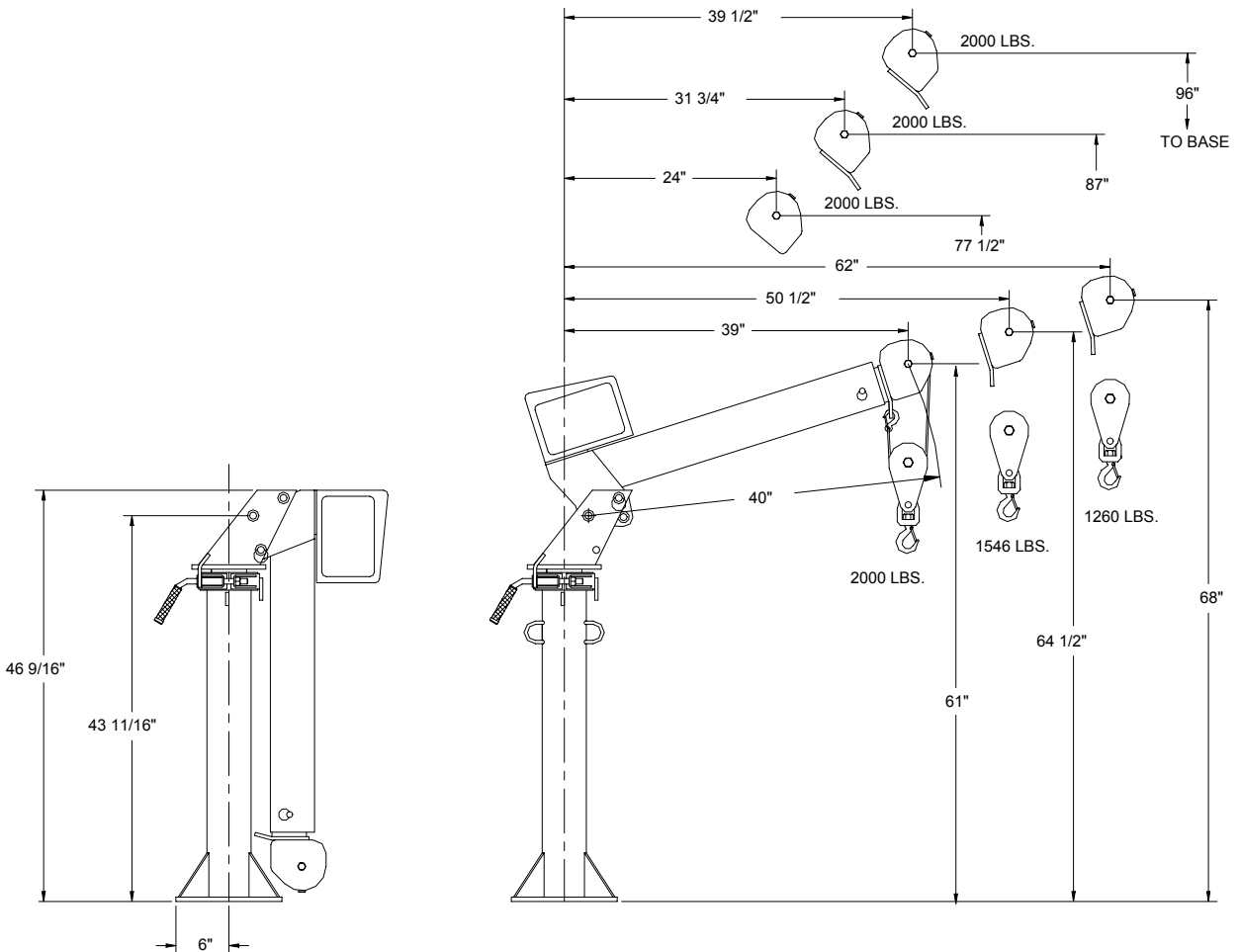
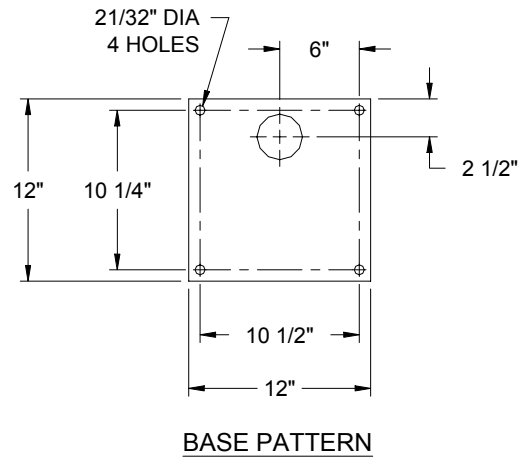
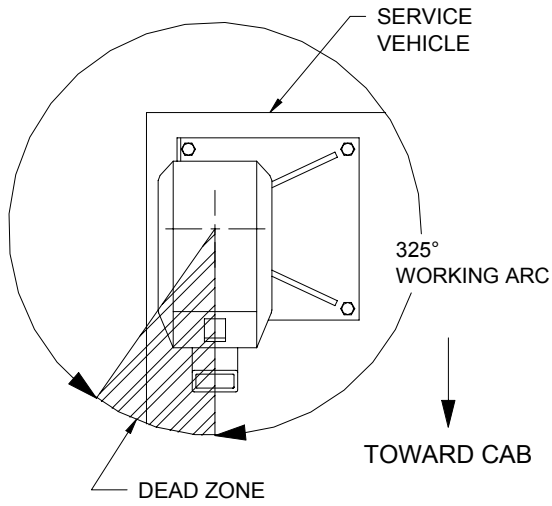

GENERAL DIMENSIONS ECONO-TON II - 7' BOOM

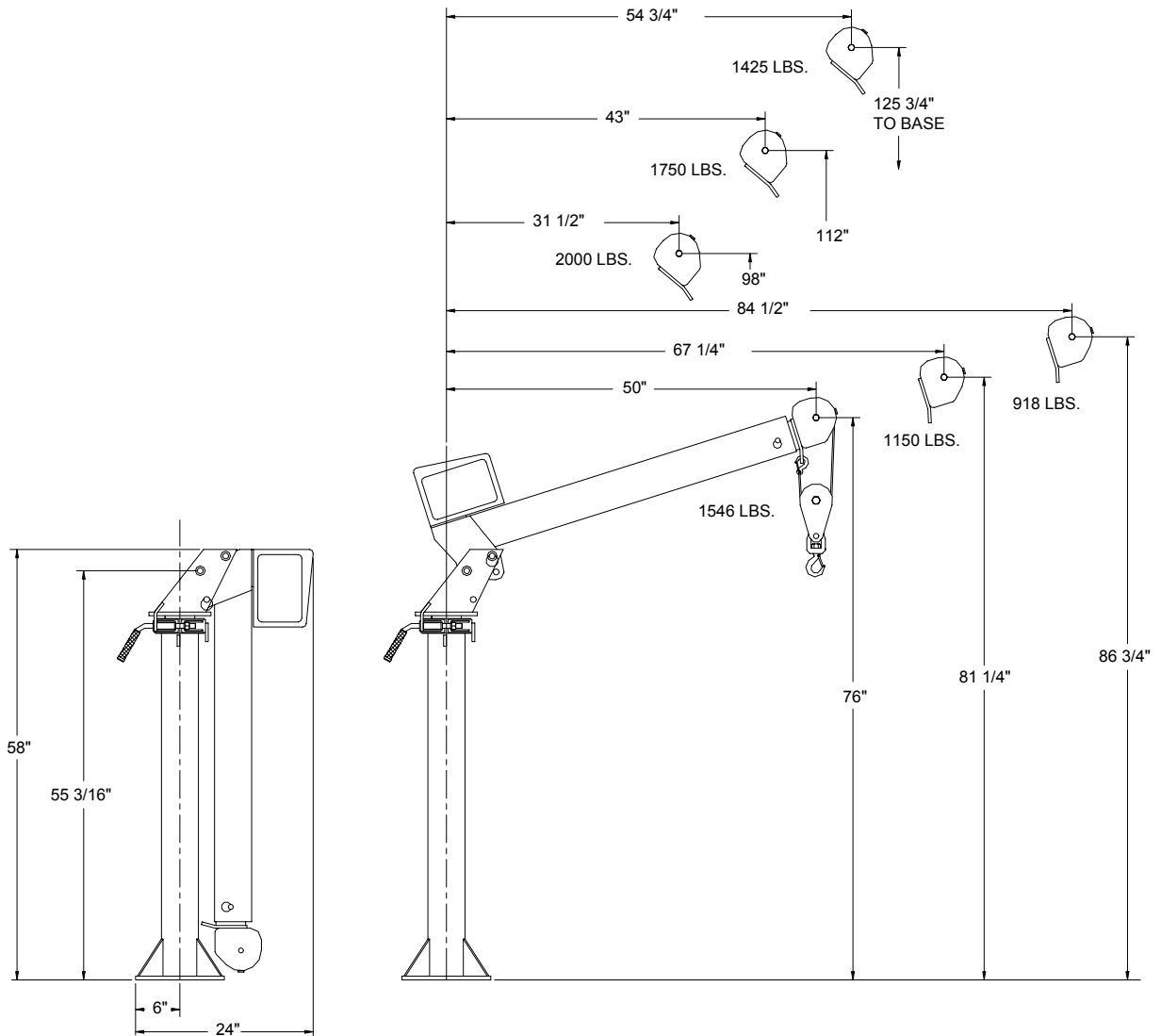
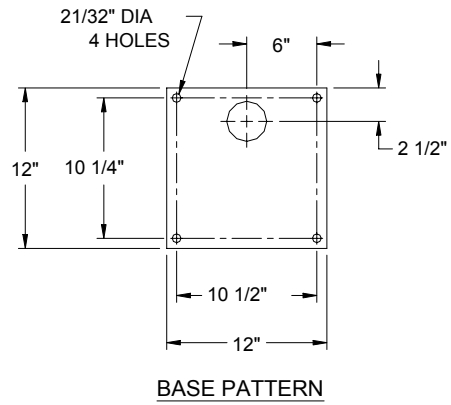
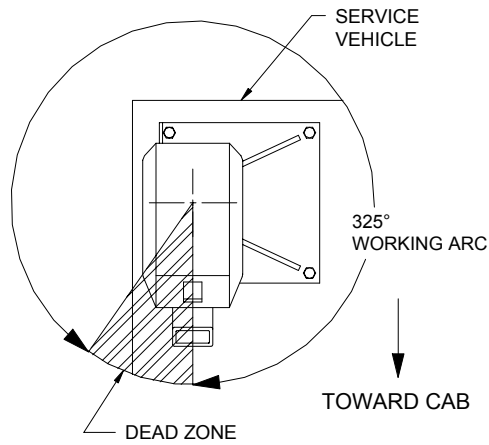

MOUNTING AND INSTALLATION

ECON-TON II / IIR

The Econo-Ton II cranes are shipped in one major assembly. The following is a suggested method for installation of the Econo-Ton II crane:

- 1 Remove the crane from the packing crate and locate on the truck bed in the desired position, checking for proper clearance.**
 - 2 If the floor is made of wood, it may be desirable to install a 3/8" plate approximately six to eight inches larger than the base plate on top of the wooden deck. If the floor is heavy metal and ribbed, no metal plate will be required under the crane base plate. Fillers should be installed to level the ribbed floor if required. The crane may now be placed in position and the base plate may be used as a template to drill the mounting holes through the truck bed and additional plates if used. Refer to Pages 3-11 and 3-12 for a typical installation.**
 - 3 Each truck has its own unique mounting difficulties. The mount and additional bracing should be constructed so the combined crane load of 6500 ft lbs and a vertical load of 2000 lbs will be directed over the largest area possible. Install a brace, which crosses both frame rails and is bolted to the frame as shown in the drawing. This brace may be square tubing and should extend out to both sides of the truck and may be used as**
- pocket for an outrigger, stabilizer, or jack leg holder. Add others structural members as required, including the back-up assembly which has been pre-drilled to match the crane mounting holes. Bolt the crane in place.
- 4 Route the long cable (power cable) under the truck and to the positive pole on the starter solenoid. Tie the power cables with insulated straps to the truck frame and other members as required. Avoid the area of the exhaust system when routing the cable.**
 - 5 Pin boom in working position.**
 - 6 Attach the removable pendant control cable and test the crane for power functions.**
 - 7 With jack legs or outriggers installed, pick up a load of 2000 pounds and manually rotate this load approximately 180° to insure that the crane is sufficiently supported and correctly installed. Further reinforcement of the truck bed may be added if required.**
 - 8 Store boom during travel. See page 3-13 for illustration.**
 - 9 ALWAYS remove pendant when traveling.**

MOUNTING AND INSTALLATION

ECON-TON II / IIR

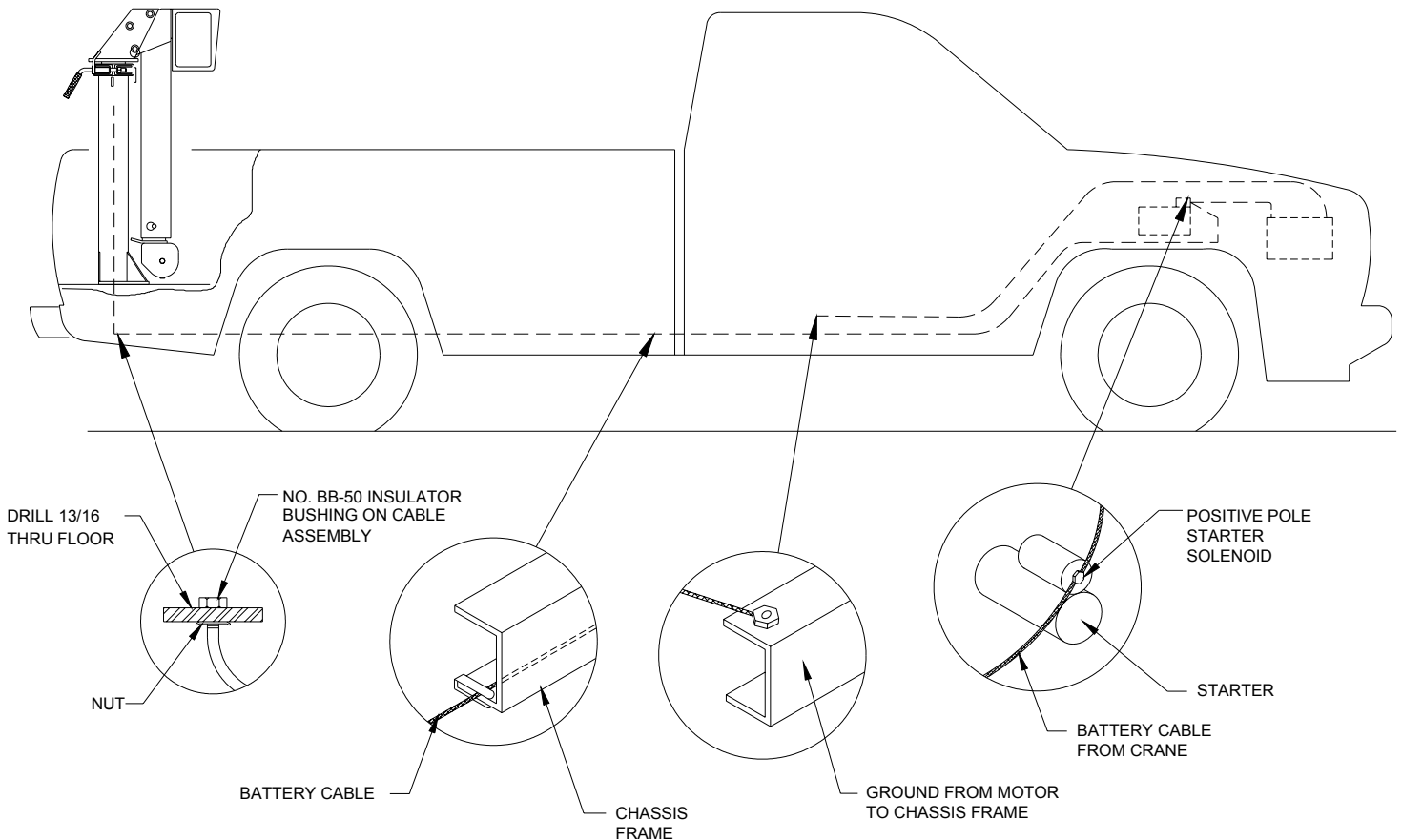

INSTALLATION-BATTERY CABLE

1. Drill 13/16" hole in floor. Install bushing, which is connected to cable, so it fits hole snug.
2. Run cable to positive battery terminal. Connect black cable to negative battery terminal or suitable chassis ground point. Locate cables so that they will be protected. Avoid sharp edges. Use the No. 083800 frame clips provided to hold cables securely in place.
3. If the battery is grounded to the engine it may be necessary to add an additional ground cable from the engine to the chassis frame to obtain maximum power at crane.

INSTALLATION INSTRUCTIONS

ECONO-TON II/IR

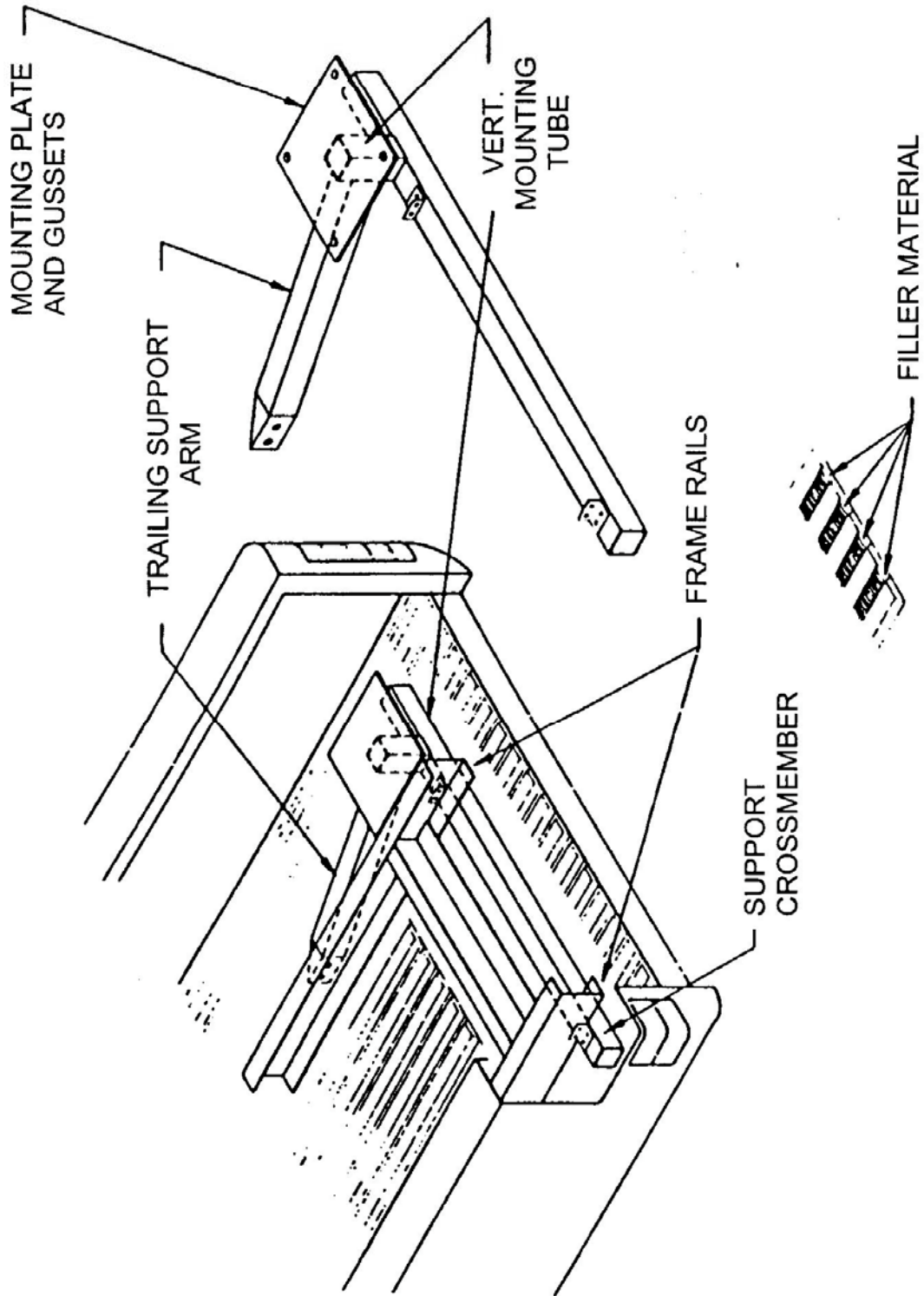

INSTALLATION INSTRUCTIONS ECONO-TON II/IR - FLATBED

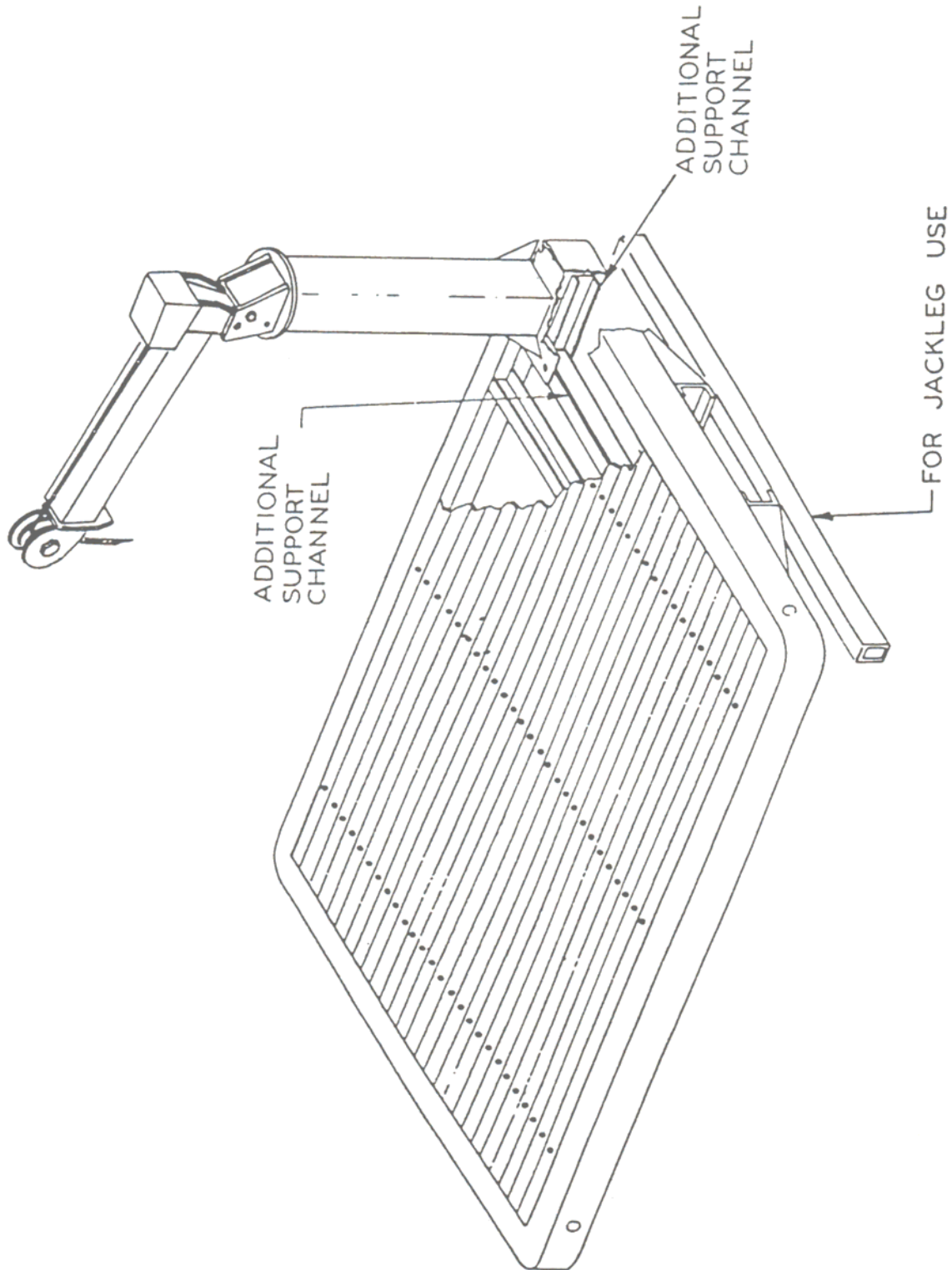

NOTES

***BOOM STORAGE
ECONO-TON II / IIR***

**CAUTION:
MAKE SURE BOOM IS PINNED
IN STORED POSITION AND
ROTATION BRAKE IS SET
BEFORE ROAD TRAVEL.**

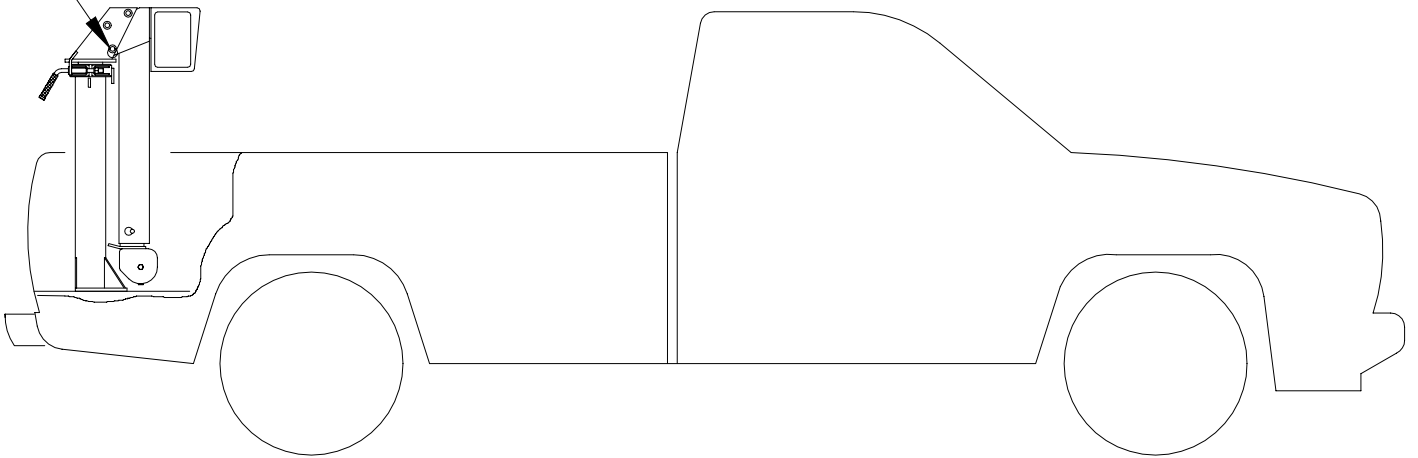

LUBRICATION & MAINTENANCE SCHEDULE

ECONO-TON II / IIR

SERVICE PERFORMED	DAY	WEEKLY	MONTH	YEAR	NOTES
LOAD HOOK	X				INSPECT HOOK & LATCH FOR DEFORMATION, CRACKS, & CORROSION
CABLE DRUM	X				MAKE SHURE CABLE IS WOUND EVENLY ON DRUM
HOIST CABLE	X				CHECK FOR FLATTENING, KINKS, & BROKEN STRANDS, SEE MANUAL
MOUNTING BOLTS		X			CHECK-TORQUE TO128 FT-LBS (DRY) AS REQUIIRED
MOTOR CONNECTION		X			CHECK TERMINALS FOR TIGHT CONNECTIONS
SHEAVE BEARINGS		X			SEALED BEARING, REPLACE IF ROUGH OR LOOSE
ALL OTHER BOLTS		X			CHECK-TIGHTEN AS REQUIRED
BATTERY CONNECTIONS		X			CHECK FOR CORROSION & TIGHT CONNECTIONS. CLEAN & COAT AS REQUIRED.
POWER CABLE			X		CHECK INSULATION FOR DAMAGE OR DETERIORATION
ROTATION GEAR			X		WATER PROOF BEARING GREASE OR DRY MOLYLUBE IF DUSTY
HUMP REDUCER				X	WATER PROOF BEARING GREASE
FOR ADDITIONAL INFORMATION SEE: 1) OWNER'S MANUAL 2) OSHA SECTION 1910.180 3) ANSI B30.5-1989					

CAUTION: Routine maintenance insures trouble-free operation and protects your investment. All warranties are void if maintenance is neglected.

NOTES:

1. Use only authorized parts. Any damage or malfunction caused by the use of unauthorized parts is not covered by Warranty or Product Liability
2. Once a bolt has been torqued to its rated capacity and then removed; the bolt should be replaced with a new one.
3. Auto Crane Company recommends that this crane be serviced per "Crane Inspection Log" P/N 999978. These logs should be filled in at the intervals noted and kept as a permanent record. Additional copies are available from your local distributor.

MAINTENANCE

ECONO-TON II / IIR

LUBRICATION OF THE ECONO-TON II

Most bearings on the winch are factory sealed and cannot be greased. Lube winch gear once a month.

The only other place to lube this crane is at the bushings in the base (P/N: 272406) of this unit. Wipe a small amount of grease (bearing type) on the bushings or stem that fits into these bushings once a month, depending on use, maybe more often.

BRAKE ADJUSTMENT - WINCH

The brake on this unit consists of two springs with pads on the ends (P/N: 272434), which rub the brake disc (P/N: 272433) on the end of the shaft coming out of the motor. This drum works free one way. Then you hoist down, it works to hold the speed and load. There is no real adjustment of this brake. If you try to bend the springs too much, they will break. These winches come with the brake already installed.

CHANGE CABLE

To change cable, hoist down to the end of the old cable on the drum. There is a small carriage bolt and clamp; loosen the bolt in the clamp to remove the cable. Replace with a new cable passed underneath the clamp. Tighten the bolt securely and re-spool the cable on the drum; maintain a light tension on the cable so the cable will spool properly.

LOWER QUILL BEARING

If lower quill bearing (P/N: 370033) is to be replaced, press until existing bearing drops to the pedestal. Press new bearing in until the edge of the bearing is even with the machined edge in the pedestal quill.

GENERAL ASSEMBLY - ECONO-TON II

P/N: 37000000 – 5' BOOM

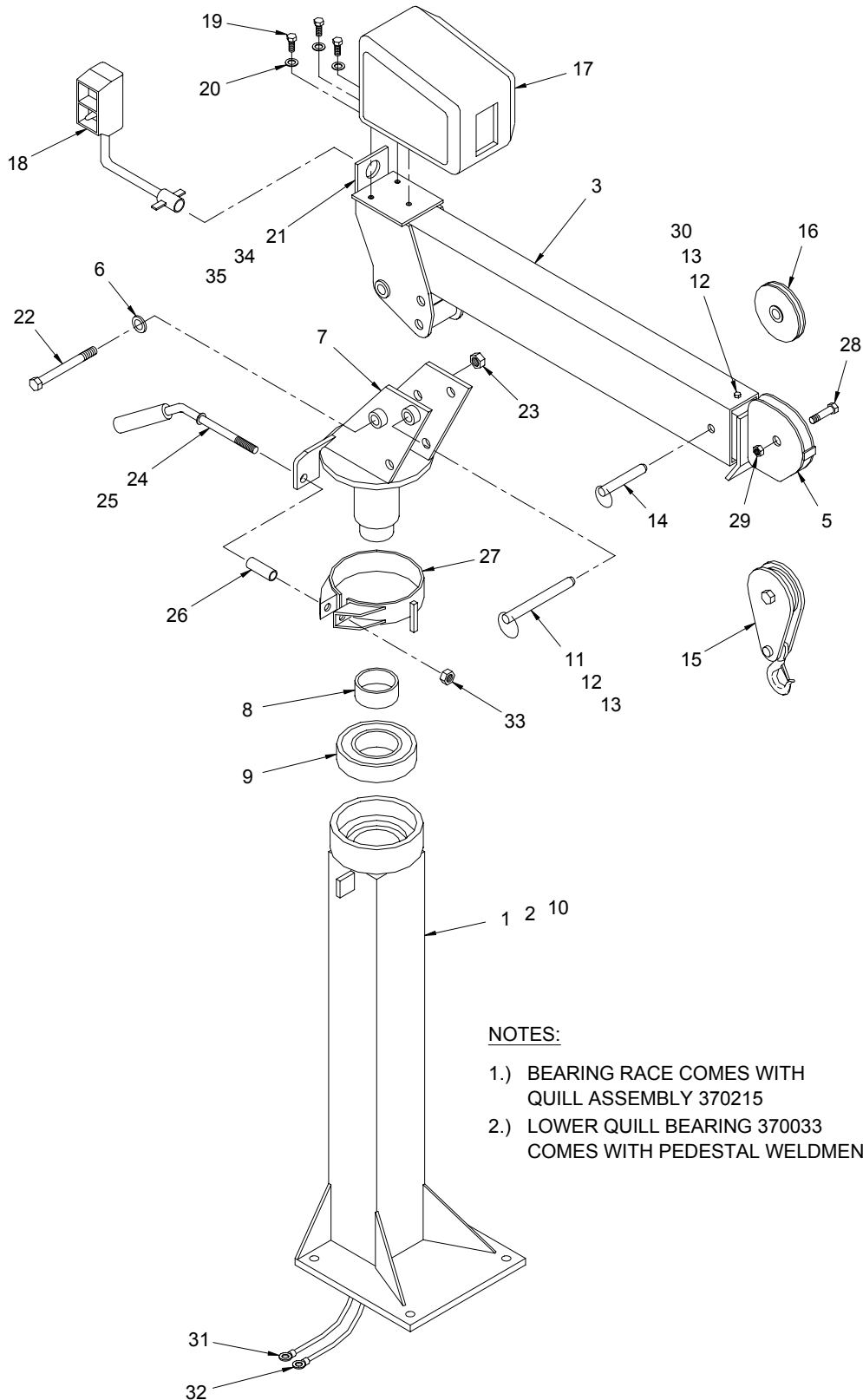

NOTES:

- 1.) BEARING RACE COMES WITH
QUILL ASSEMBLY 370215
- 2.) LOWER QUILL BEARING 370033
COMES WITH PEDESTAL WELDMENT

GENERAL ASSEMBLY - ECONO-TON II
P/N: 37000000 – 5' BOOM

ITEM NO.	QTY.	PART NO.	DESCRIPTION
1	1	370216000	PEDESTAL WELDMENT
2	1	370065000	DECAL KIT
3	1	370040000	LOWER BOOM
4	1	370016000	CABLE PROTECTOR - INSTALLATION
5	1	370041000	UPPER BOOM
6	1	022102000	WASHER FL 3/4
7	1	370215000	QUILL ASSEMBLY
8	1	370034000	BEARING RACE (SEE NOTE #1)
9	1	330192000	BEARING BALL
10	1	370033000	BEARING NEEDLE ROLLER (SEE NOTE #2)
11	1	370001000	LOCK PIN
12	2	005901000	SCW HX HD 1/4NC
13	2	020200000	WASHER SP LK 1/4
14	1	370002000	LOCK PIN
15	1	100300000	TRAVELING BLOCK
16	1	227401000	SHEAVE ASSEMBLY (BEARING ONLY 200100)
17	1	272419000	WINCH ASSEMBLY
18	1	370129000	PENDANT
19	3	010000000	SCW 1/2 NC X 1/2
20	3	021500000	WASHER SP LK 1/2
21	1	370022000	RECEPTACLE ASSEMBLY
22	1	014302000	SCW HX HD 3/4 NF X 7
23	1	018600000	NUT HX LK 3/4 NF
24	1	371048000	HANDLE BRAKE
25	1	272055000	GRIP HANDLE
26	1	370220000	SPACER BRAKE
27	1	370217000	BRAKE BAND WELDMENT
28	1	012200000	SCW HDX HD 5/8 NF X 1 3/4
29	1	018100000	NUT HX LK 5/8 NF
30	1	370005000	EXTENSION LOCK PAD
31	1	602005000	POWER CABLE
32	1	602006000	GROUND CABLE
33	1	018301000	NUT HX 5/8 NC
34	2	015900000	NUT 1/4 NC
35	2	020201000	WASHER INT LK 1/4

GENERAL ASSEMBLY - ECONO-TON II

P/N: 37000001 – 7' BOOM

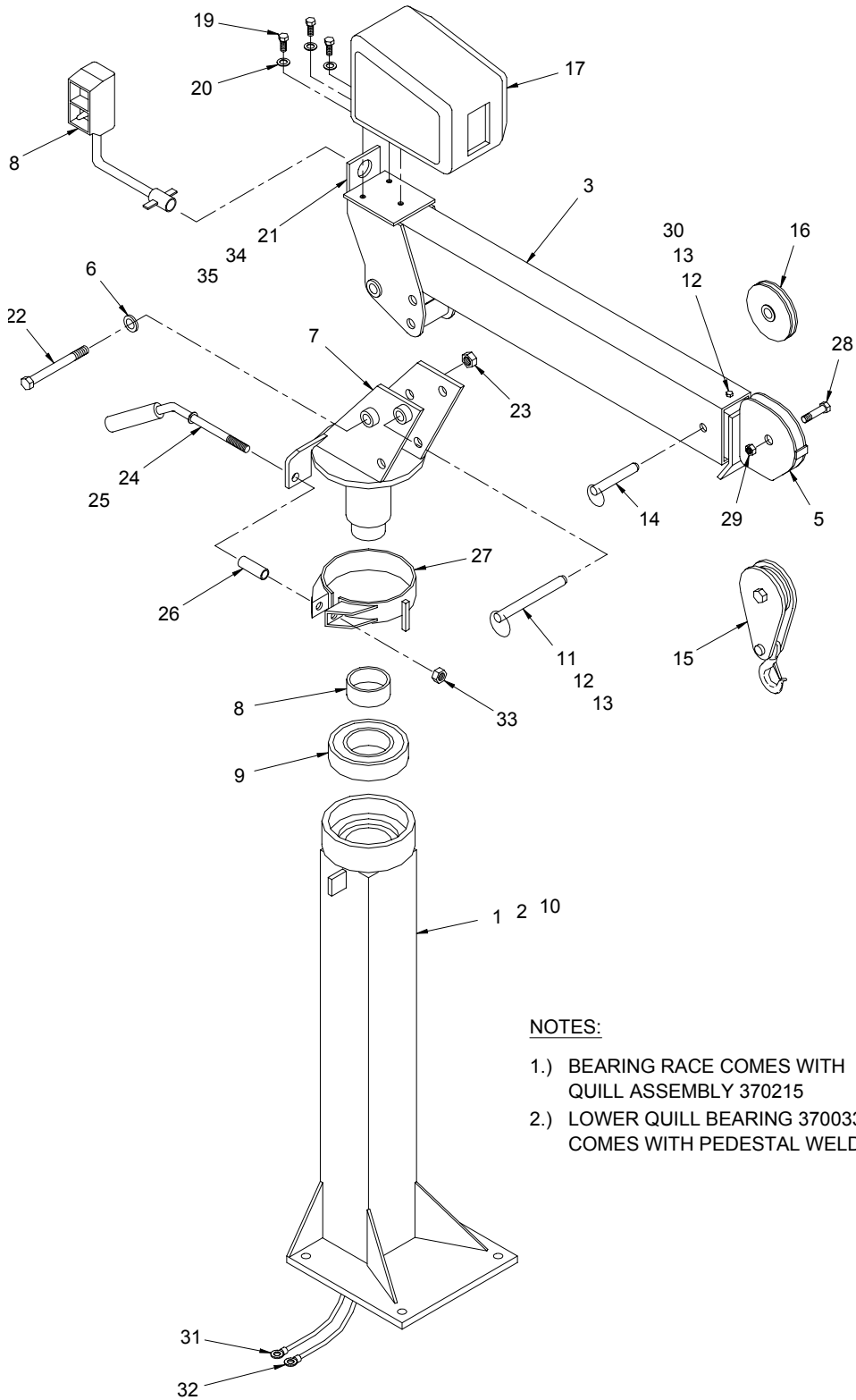

NOTES:

- 1.) BEARING RACE COMES WITH
QUILL ASSEMBLY 370215
- 2.) LOWER QUILL BEARING 370033
COMES WITH PEDESTAL WELDMENT

GENERAL ASSEMBLY - ECONO-TON II
P/N: 37000001 – 7' BOOM

ITEM NO.	QTY.	PART NO.	DESCRIPTION
1	1	370216001	PEDESTAL WELDMENT
2	1	370066000	DECAL KIT
3	1	370045000	LOWER BOOM
4	1	370016000	CABLE PROTECTOR - INSTALLATION
5	1	370046000	UPPER BOOM
6	1	022102000	WASHER FL 3/4
7	1	370215000	QUILL ASSEMBLY
8	1	370034000	BEARING RACE (SEE NOTE #1)
9	1	330192000	BEARING BALL
10	1	370033000	BEARING NEEDLE ROLLER (SEE NOTE #2)
11	1	370001000	LOCK PIN
12	2	005901000	SCW HX HD 1/4NC
13	2	020200000	WASHER SP LK 1/4
14	1	370002000	LOCK PIN
15	1	100300000	TRAVELING BLOCK
16	1	227401000	SHEAVE ASSEMBLY (BEARING ONLY 200100)
17	1	272419000	WINCH ASSEMBLY
18	1	370129000	PENDANT
19	3	010000000	SCW 1/2 NC X 1/2
20	3	021500000	WASHER SP LK 1/2
21	1	370022000	RECEPTACLE ASSEMBLY
22	1	014302000	SCW HX HD 3/4 NF X 7
23	1	018600000	NUT HX LK 3/4 NF
24	1	371048000	HANDLE BRAKE
25	1	272055000	GRIP HANDLE
26	1	370220000	SPACER BRAKE
27	1	370217000	BRAKE BAND WELDMENT
28	1	012200000	SCW HDX HD 5/8 NF X 1 3/4
29	1	018100000	NUT HX LK 5/8 NF
30	1	370005000	EXTENSION LOCK PAD
31	1	602005000	POWER CABLE
32	1	602006001	GROUND CABLE
33	1	018301000	NUT HX 5/8 NC
34	2	015900000	NUT 1/4 NC
35	2	020201000	WASHER INT LK 1/4

GENERAL ASSEMBLY - ECONO-TON II

P/N: 3700865000 – 5' BOOM

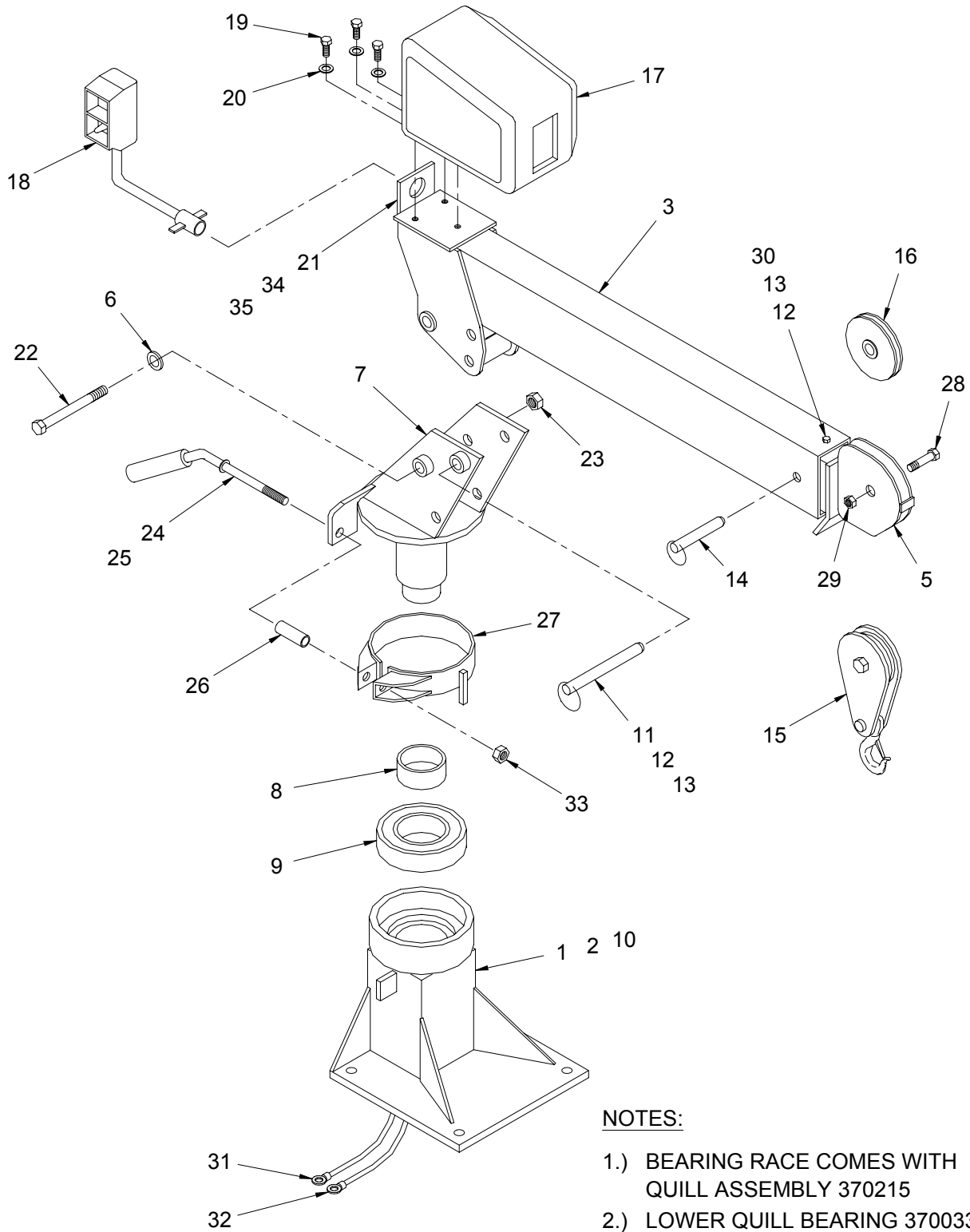

NOTES:

- 1.) BEARING RACE COMES WITH QUILL ASSEMBLY 370215
- 2.) LOWER QUILL BEARING 370033 COMES WITH PEDESTAL WELDMENT

GENERAL ASSEMBLY - ECONO-TON II
P/N: 3700865000 – 5' BOOM

ITEM NO.	QTY.	PART NO.	DESCRIPTION
1	1	370861001	PEDESTAL WELDMENT
2	1	370065001	DECAL KIT
3	1	370040000	LOWER BOOM
4	1	370016000	CABLE PROTECTOR - INSTALLATION
5	1	370041000	UPPER BOOM
6	1	022102000	WASHER FL 3/4
7	1	370215000	QUILL ASSEMBLY
8	1	370034000	BEARING RACE (SEE NOTE #1)
9	1	330192000	BEARING BALL
10	1	370033000	BEARING NEEDLE ROLLER (SEE NOTE #2)
11	1	370001000	LOCK PIN
12	2	005901000	SCW HX HD 1/4NC
13	2	020200000	WASHER SP LK 1/4
14	1	370002000	LOCK PIN
15	1	100300000	TRAVELING BLOCK
16	1	227401000	SHEAVE ASSEMBLY (BEARING ONLY 200100)
17	1	272419000	WINCH ASSEMBLY
18	1	370129000	PENDANT
19	3	010000000	SCW 1/2 NC X 1/2
20	3	021500000	WASHER SP LK 1/2
21	1	370022000	RECEPTACLE ASSEMBLY
22	1	014302000	SCW HX HD 3/4 NF X 7
23	1	018600000	NUT HX LK 3/4 NF
24	1	371048000	HANDLE BRAKE
25	1	272055000	GRIP HANDLE
26	1	370220000	SPACER BRAKE
27	1	370217000	BRAKE BAND WELDMENT
28	1	012200000	SCW HDX HD 5/8 NF X 1 3/4
29	1	018100000	NUT HX LK 5/8 NF
30	1	370005000	EXTENSION LOCK PAD
31	1	602005000	POWER CABLE
32	1	602006000	GROUND CABLE
33	1	018301000	NUT HX 5/8 NC
34	2	015900000	NUT 1/4 NC
35	2	020201000	WASHER INT LK 1/4

GENERAL ASSEMBLY - ECONO-TON II

P/N: 3700860000 – 7' BOOM

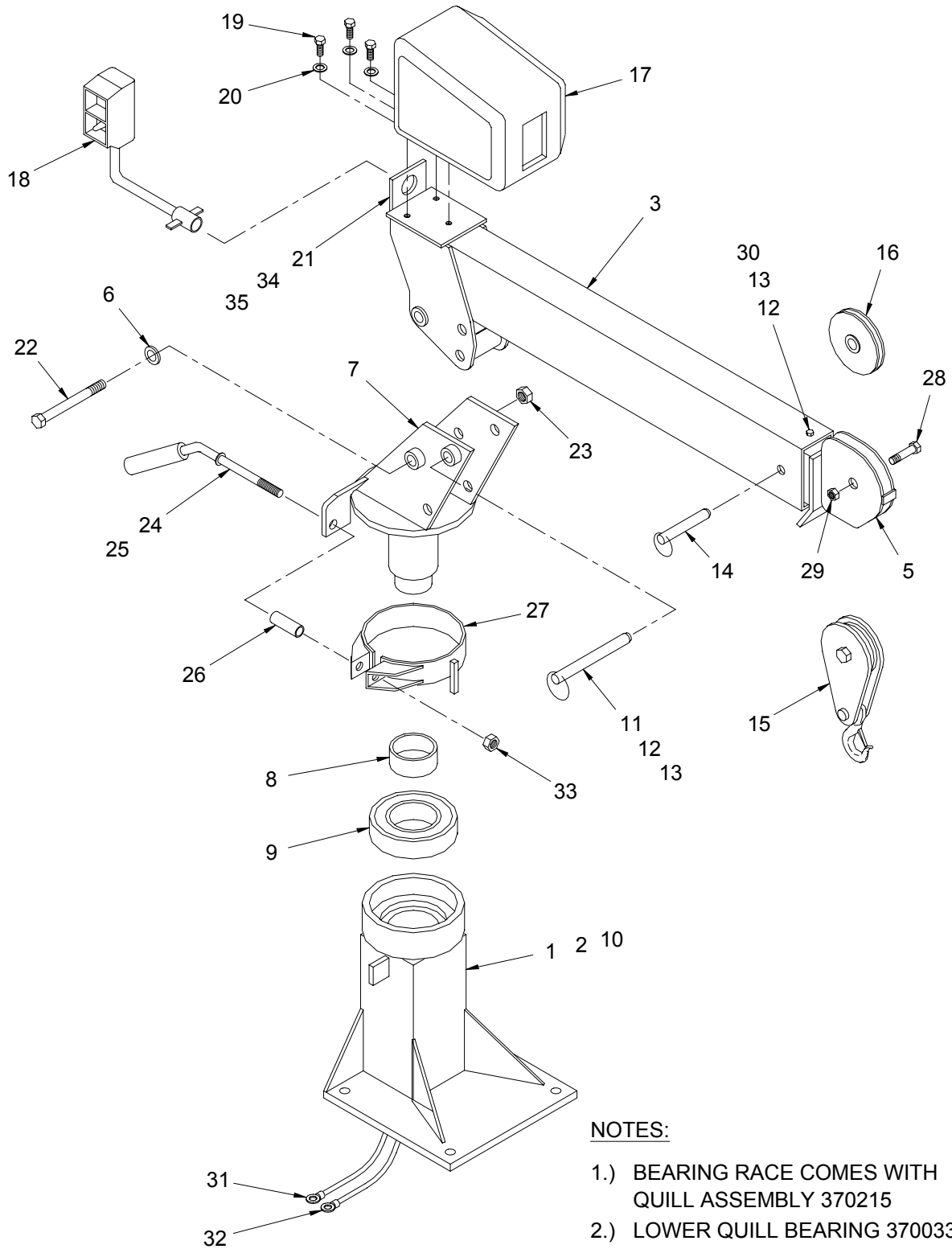

NOTES:

- 1.) BEARING RACE COMES WITH
QUILL ASSEMBLY 370215
- 2.) LOWER QUILL BEARING 370033
COMES WITH PEDESTAL WELDMENT

GENERAL ASSEMBLY - ECONO-TON II
P/N: 3700860000 – 7' BOOM

ITEM NO.	QTY.	PART NO.	DESCRIPTION
1	1	370861000	PEDESTAL WELDMENT
2	1	370066001	DECAL KIT
3	1	370045000	LOWER BOOM
4	1	370016000	CABLE PROTECTOR - INSTALLATION
5	1	370046000	UPPER BOOM
6	1	022102000	WASHER FL 3/4
7	1	370215000	QUILL ASSEMBLY
8	1	370034000	BEARING RACE (SEE NOTE #1)
9	1	330192000	BEARING BALL
10	1	370033000	BEARING NEEDLE ROLLER (SEE NOTE #2)
11	1	370001000	LOCK PIN
12	2	005901000	SCW HX HD 1/4NC
13	2	020200000	WASHER SP LK 1/4
14	1	370002000	LOCK PIN
15	1	100300000	TRAVELING BLOCK
16	1	227401000	SHEAVE ASSEMBLY (BEARING ONLY 200100)
17	1	272419000	WINCH ASSEMBLY
18	1	370129000	PENDANT
19	3	010000000	SCW 1/2 NC X 1/2
20	3	021500000	WASHER SP LK 1/2
21	1	370022000	RECEPTACLE ASSEMBLY
22	1	014302000	SCW HX HD 3/4 NF X 7
23	1	018600000	NUT HX LK 3/4 NF
24	1	371048000	HANDLE BRAKE
25	1	272055000	GRIP HANDLE
26	1	370220000	SPACER BRAKE
27	1	370217000	BRAKE BAND WELDMENT
28	1	012200000	SCW HDX HD 5/8 NF X 1 3/4
29	1	018100000	NUT HX LK 5/8 NF
30	1	370005000	EXTENSION LOCK PAD
31	1	602005000	POWER CABLE
32	1	370863000	GROUND CABLE
33	1	018301000	NUT HX 5/8 NC
34	2	015900000	NUT 1/4 NC
35	2	020201000	WASHER INT LK 1/4

WINCH ASSEMBLY

P/N: 272419000

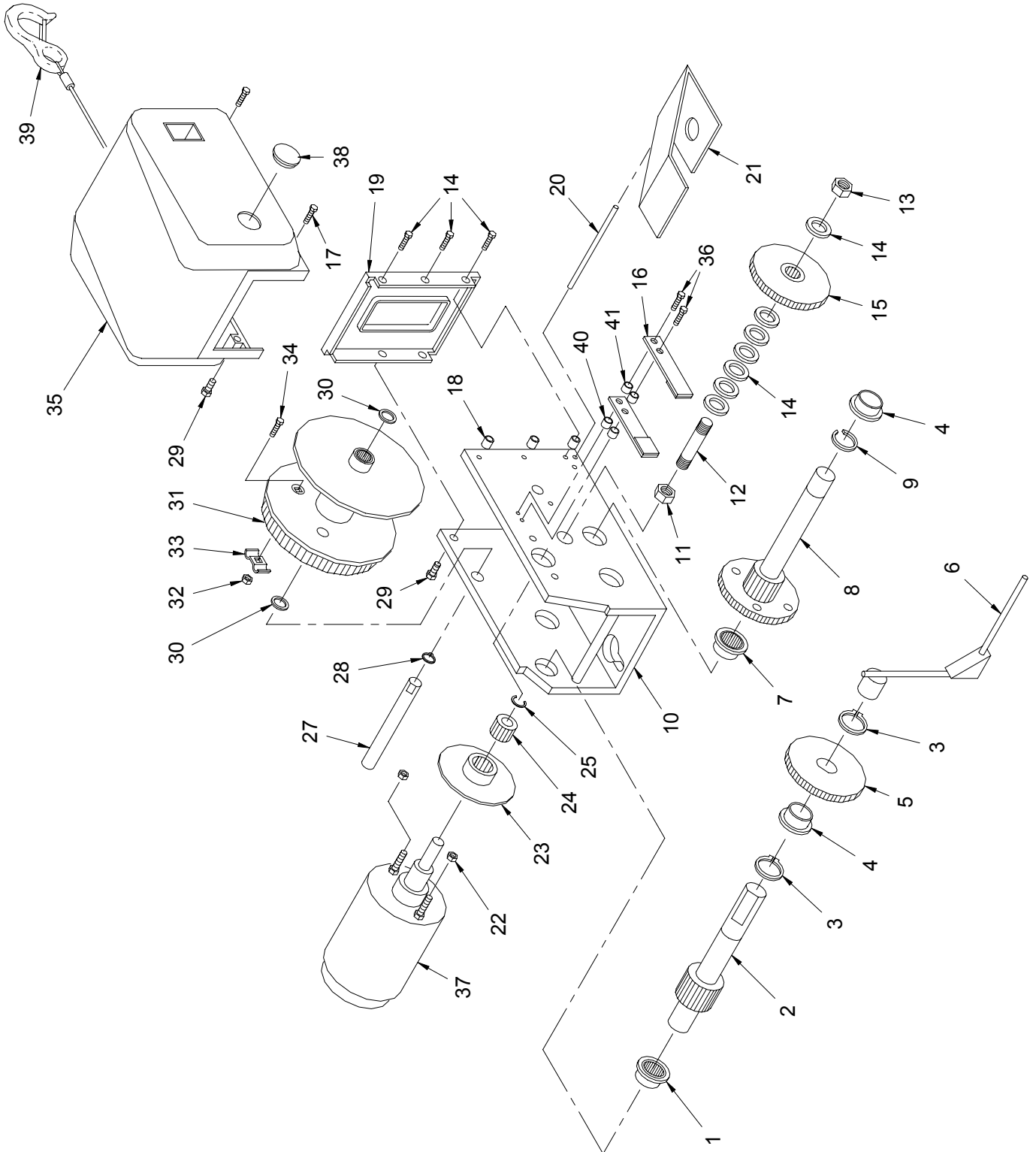

WINCH ASSEMBLY

P/N: 272419000

ITEM NO.	QTY.	PART NO.	DESCRIPTION
1	1	272500000	BEARING HOUSING ASSEMBLY
2	1	272151000	PRIMARY DRIVE SHAFT ASSEMBLY
3	2	272152000	RETAINING RING
4	2	272153000	BUSHING
5	1	272154000	GEAR 56 T
6	1	272155000	HANDLE ASSEMBLY
7	1	272501000	DRIVE SHAFT BEARING HOUSING ASSEMBLY
8	1	272158000	INTERMEDIATE DRIVE SHAFT ASSEMBLY
9	1	272159000	"E" RING
10	1	272160000	BASE
11	1	330011000	NUT HX LK 7/16 NF
12	1	330012000	CLUTCH STUD
13	1	330018000	NUT LK 1/2
14	7	272502000	WASHER
15	1	330015000	GEAR ASSEMBLY
16	2	272434000	BRAKE SPRING ASSEMBLY
17	5	272162000	SCW 1/4 NC X 1 1/16
18	3	272163000	SPACER
19	1	272164000	FRONT PLATE
20	1	272165000	LEVEL WIND PIN
21	1	330019000	LEVEL WIND
22	2	330022000	NUT HX LK #10 NF
23	1	272433000	BRAKE DISC ASSEMBLY
24	1	272170000	12 T PINION GEAR
25	1	272171000	"E" RING
26	1	272172000	BASE SPACER
27	1	272173000	REEL SHAFT
28	1	272174000	RETAINING RING
29	4	272175000	SCW 1/4 NC X 3/4
30	2	272176000	WASHER
31	1	272503000	REEL ASSEMBLY
32	1	272179000	NUT HX 1/4 NC
33	1	272180000	ROPE CLAMP
34	1	272504000	CARRAGE BOLT 1/4 NC X 3/4
35	1	272505000	COVER
36	2	272437000	SCW #10 NF X 1
37	1	272184000	MOTOR ASSEMBLY
38	1	272508000	COVER PLUG
39	1	330028000	CABLE & HOOK (3/16 X 25")
40	2	272435000	SPACER
41	2	272436000	BRAKE SPRING SPACER

NOTES

TRAVELING BLOCK ASSEMBLY

P/N: 10030000

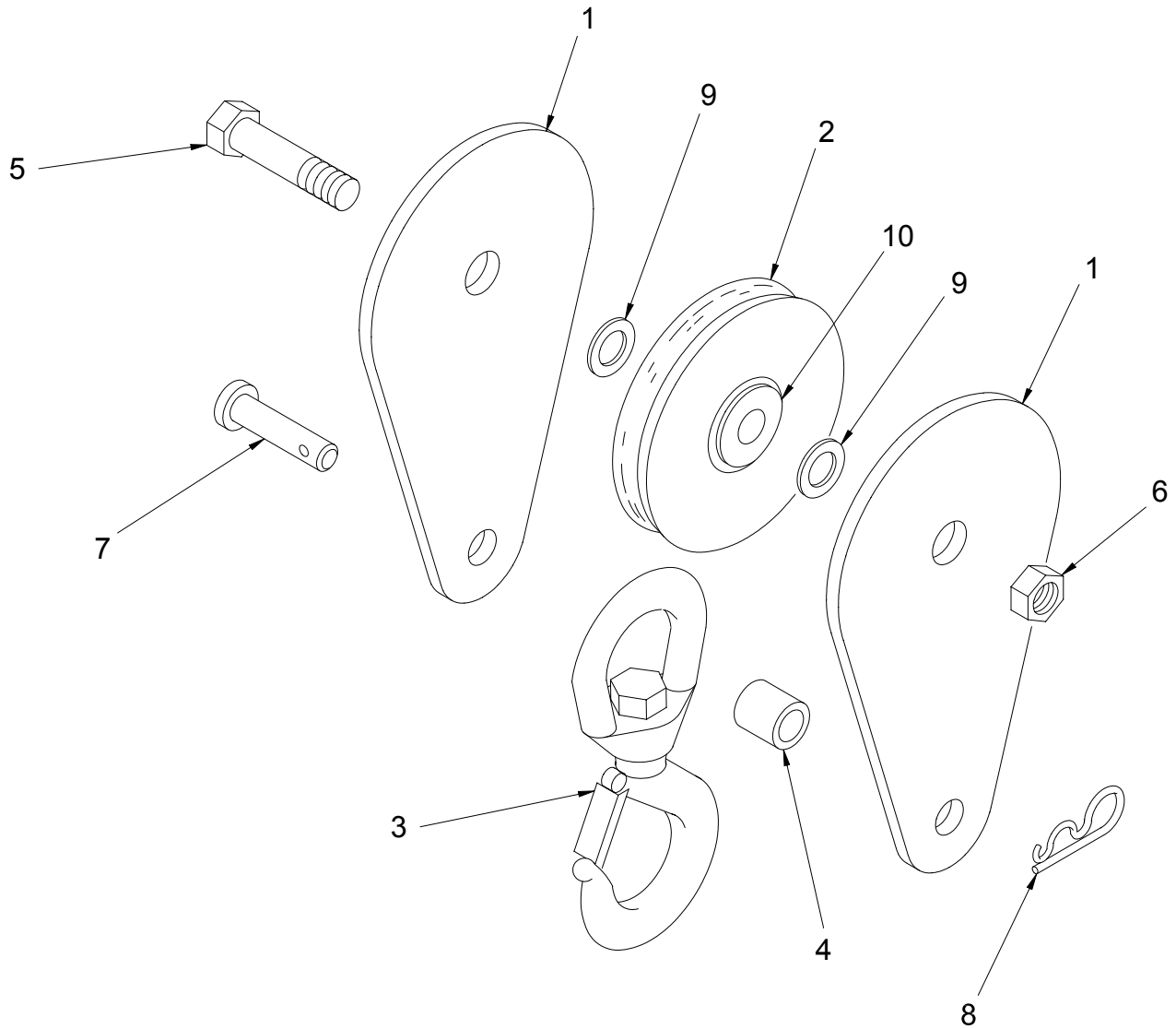

ITEM NO.	QTY.	PART NO.	DESCRIPTION
1	2	100303000	SHEAVE SIDE PLATE
2	1	200909000	SHEAVE ASSEMBLY
3	1	100309000	SWIVEL HOOK ASSEMBLY W/LATCH
4	1	340317000	PIPE BLACK 1/2
5	1	013507000	SCW HX 5/8-18 X 2 GR5
6	1	018100000	NUT HX HLF LK 5/8-18
7	1	330634000	PIN TRAVELING BLOCK
8	1	360124000	HITCH PIN
9	2	330100000	WASHER FL ADJUSTING

CRANE WIRING ECONO-TON II

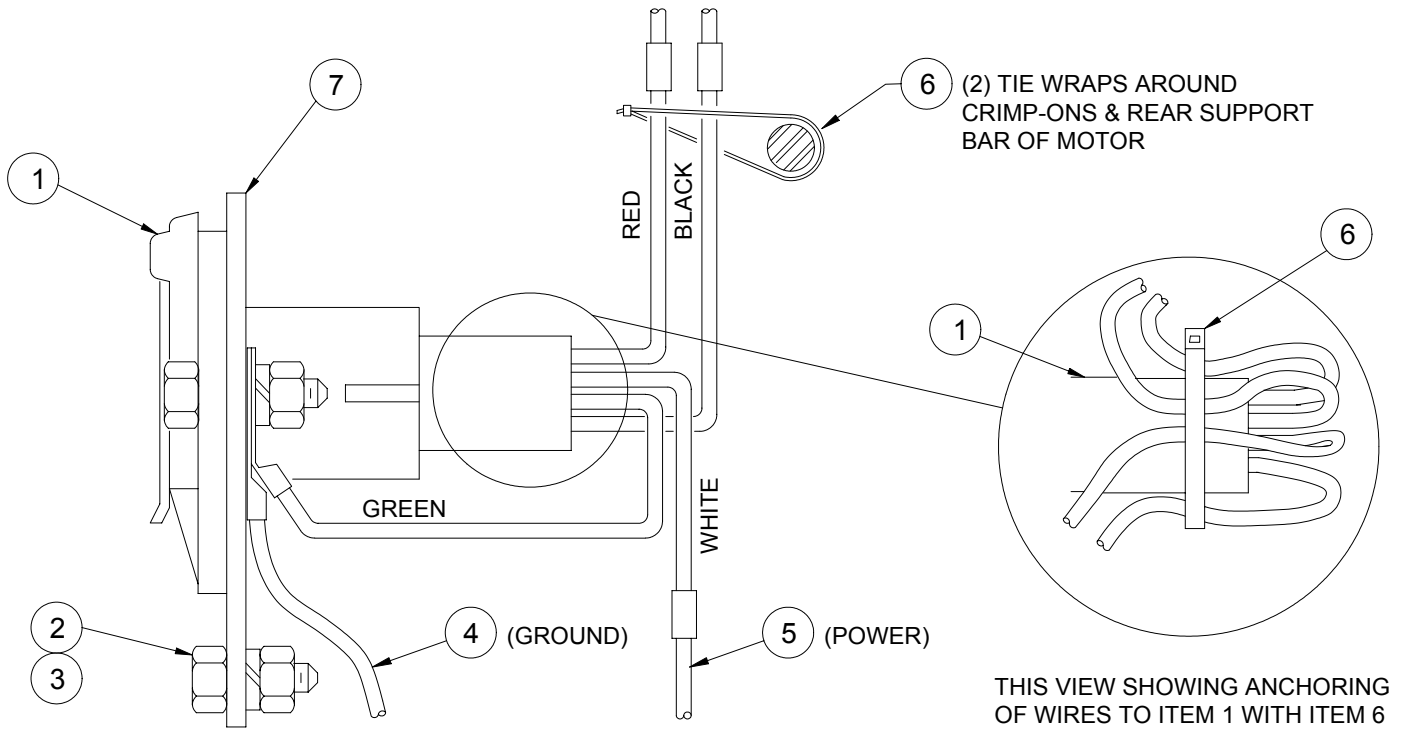

ITEM NO.	QTY.	PART NO.	DESCRIPTION
1	1	370022000	RECEPTACLE ASSEMBLY
2	2	020201000	WASHER INT LK
3	2	015900000	NUT 1/4 NC
4	1	602006000	CABLE GROUND
5	1	602005000	CABLE POWER
6	3	750737000	TIE WRAPS

PENDANT ASSEMBLY

P/N: 370129000

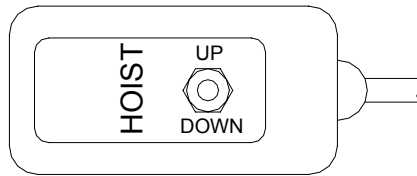
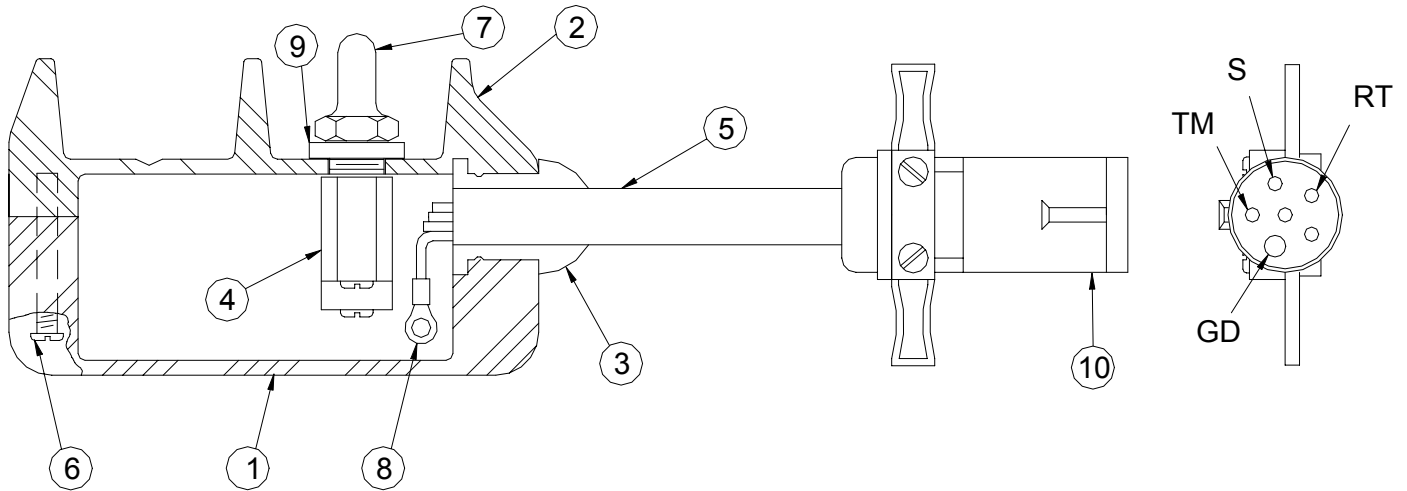

DECAL LAYOUT

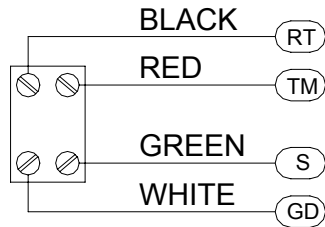

ITEM NO.	QTY.	PART NO.	DESCRIPTION
1	1	370130000	PENDANT BOX
2	1	370131000	PENDANT COVER
3	1	370132000	PENDANT HOUSING GASKET
4	1	370136000	TOGGLE SWITCH
5	10 FT	800616000	CONDUCTOR CABLE
6	4	001207000	SCW RECESSED CROSS PAN HD #8 X 1
7	1	640300000	BOOT
8	4	001002000	TERMINAL RING
9	1	370135000	SEAL WASHER
10	1	642802000	CONNECTOR PLUG
11	1	370202000	DECAL HOIST UP / DOWN

LOAD CHART
P/N: 370053000

ECONO-TON II

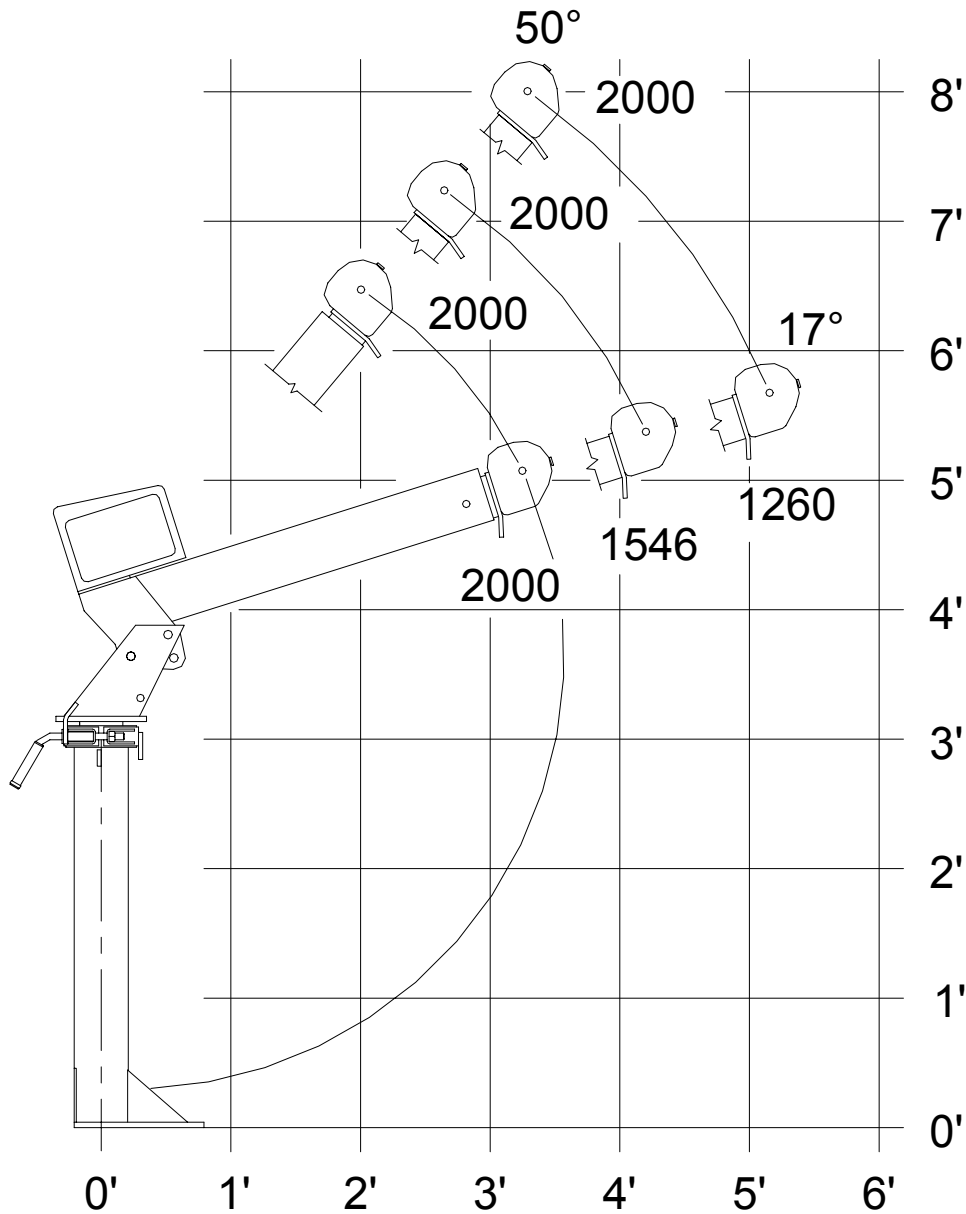

0-1000# SINGLE LINE
 1000# -UP DOUBLE LINE

P/N 370053

LOAD CHART – 7' BOOM

P/N: 370054000

ECONO-TON II

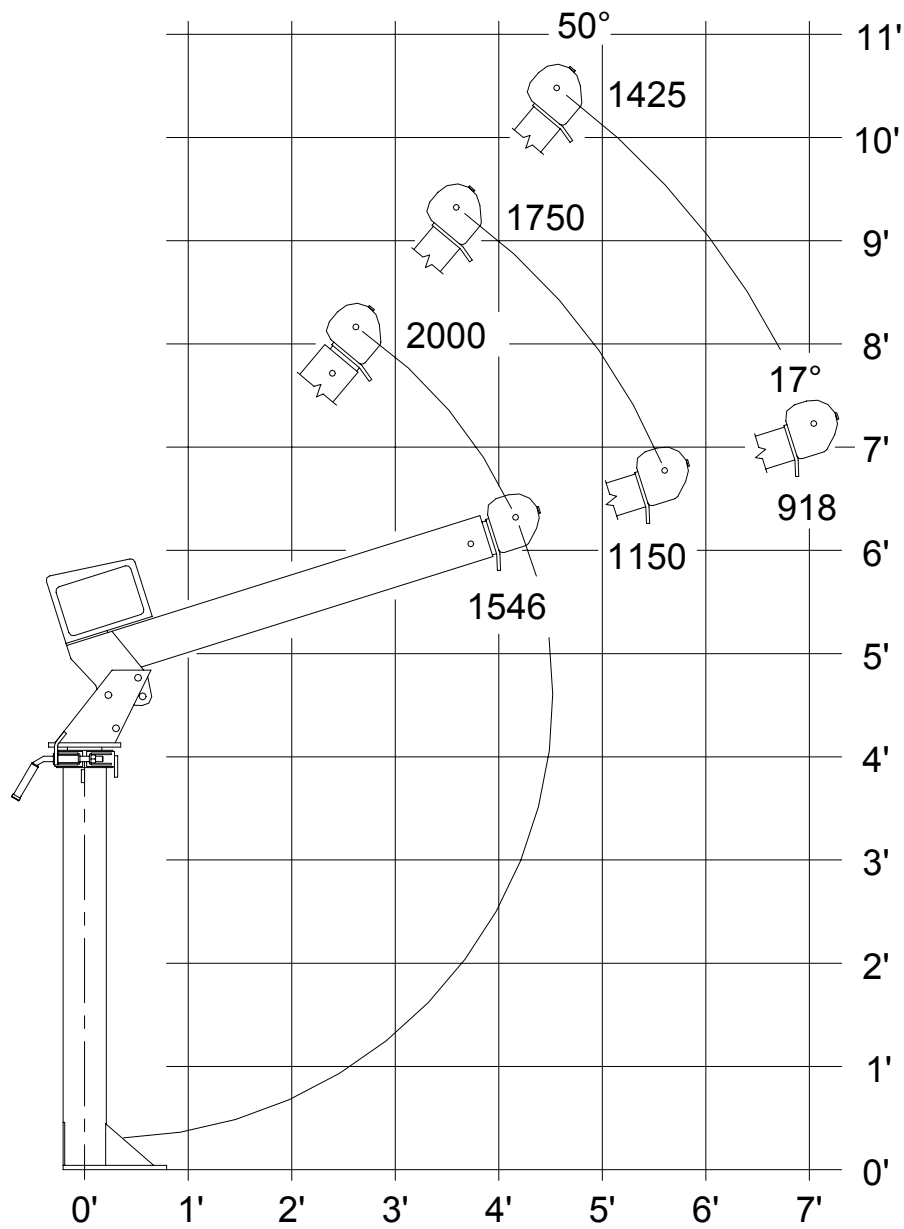

0-1000# SINGLE LINE
1000# -UP DOUBLE LINE

P/N 370054

ADDENDUM SECTION
ECONO-TON IIR
(POWER ROTATION)

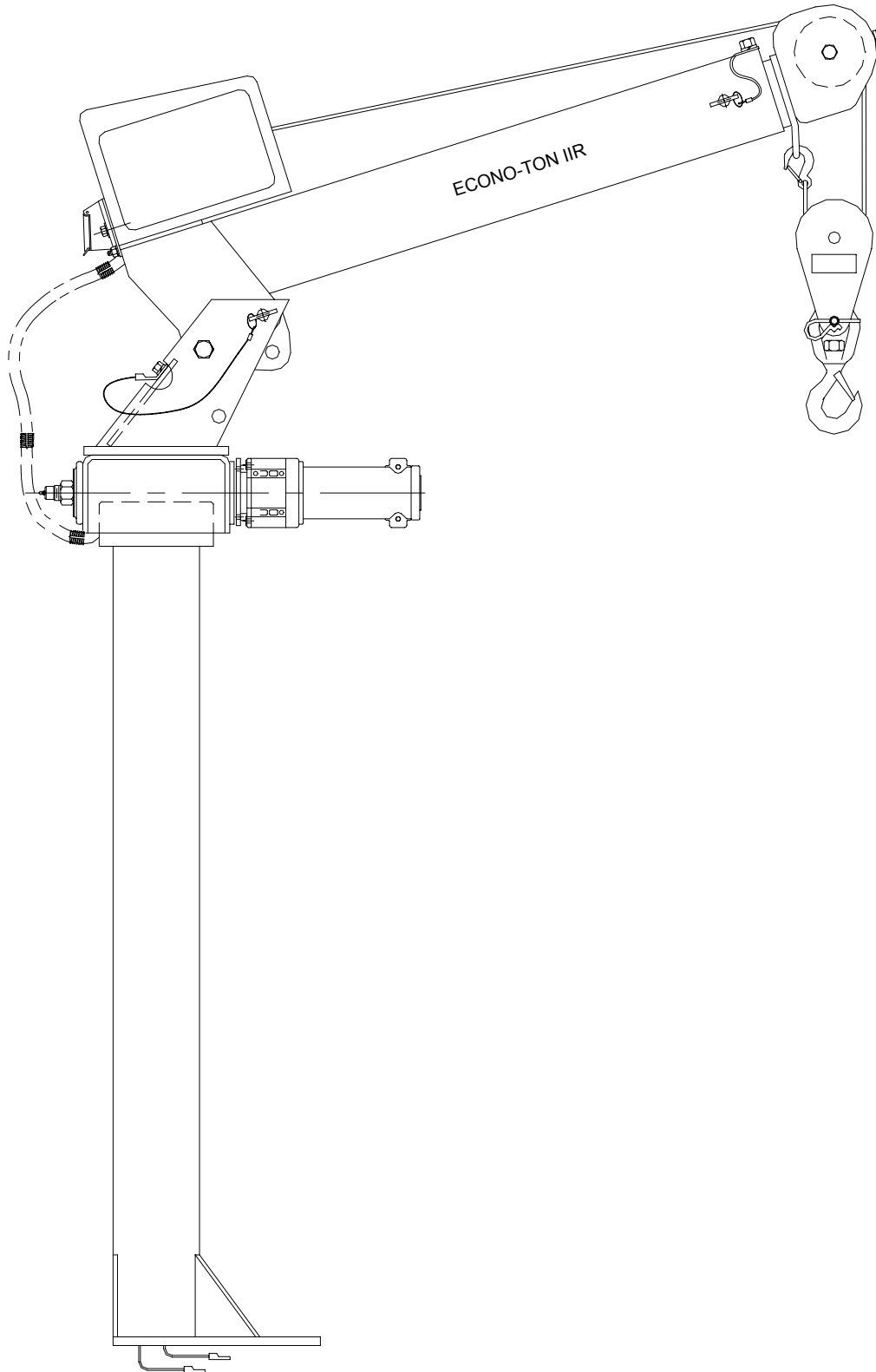

DECAL KIT - ECONO-TON IIR

P/N: 370071000 – 5' BOOM

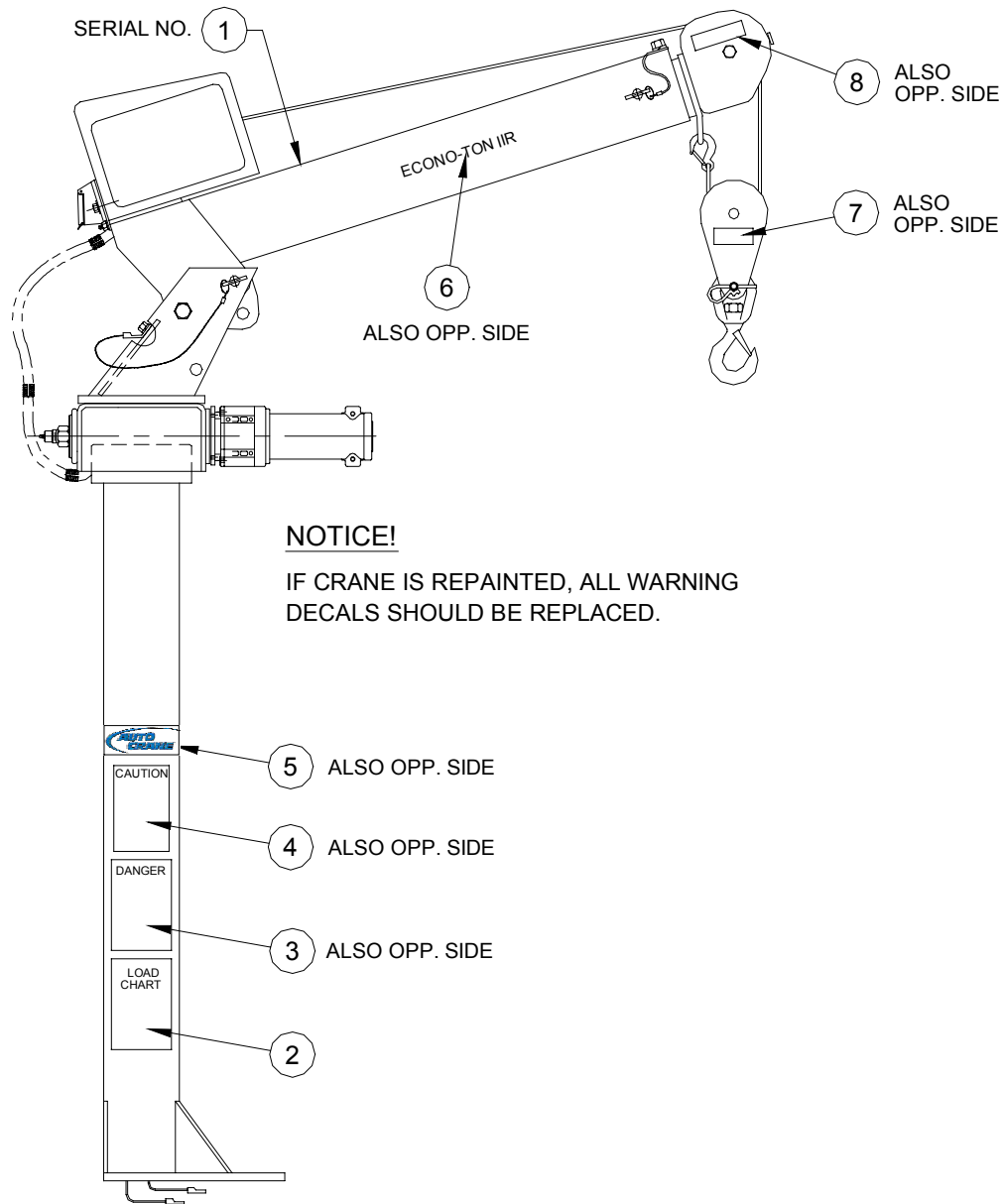

NOTICE!

IF CRANE IS REPAINTED, ALL WARNING DECALS SHOULD BE REPLACED.

ITEM NO.	QTY.	PART NO.	DESCRIPTION
1	1	330622	DECAL, SERIAL NO.
2	1	370055	DECAL, LOAD CHART
3	2	040580	DECAL, DANGER
4	2	040579	DECAL, CAUTION
5	2	040619	DECAL, AUTO CRANE
6	2	370512	DECAL, ECONO-TON IIR
7	2	040630	DECAL, DANGER
8	2	040517	DECAL, DANGER STAY CLEAR OF BOOM

DECAL KIT - ECONO-TON IIR

P/N: 370072000 – 7' BOOM

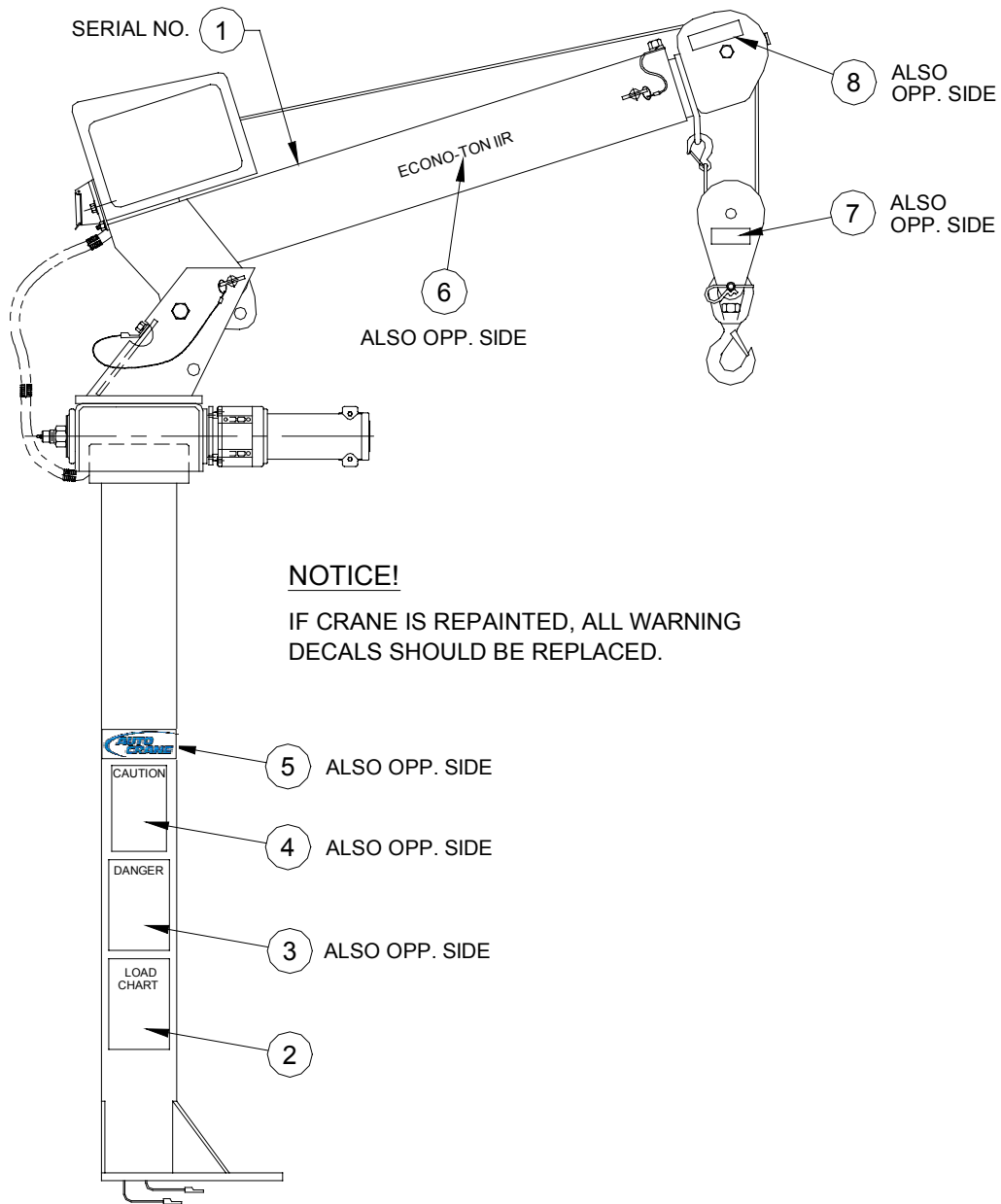

ITEM NO.	QTY.	PART NO.	DESCRIPTION
1	1	330622	DECAL, SERIAL NO.
2	1	370057	DECAL, LOAD CHART
3	2	040580	DECAL, DANGER
4	2	040579	DECAL, CAUTION
5	2	040619	DECAL, AUTO CRANE
6	2	370512	DECAL, ECONO-TON II
7	2	040630	DECAL, DANGER
8	2	040517	DECAL, DANGER STAY CLEAR OF BOOM

GENERAL DIMENSIONS

ECONO-TON IIR – 5' BOOM

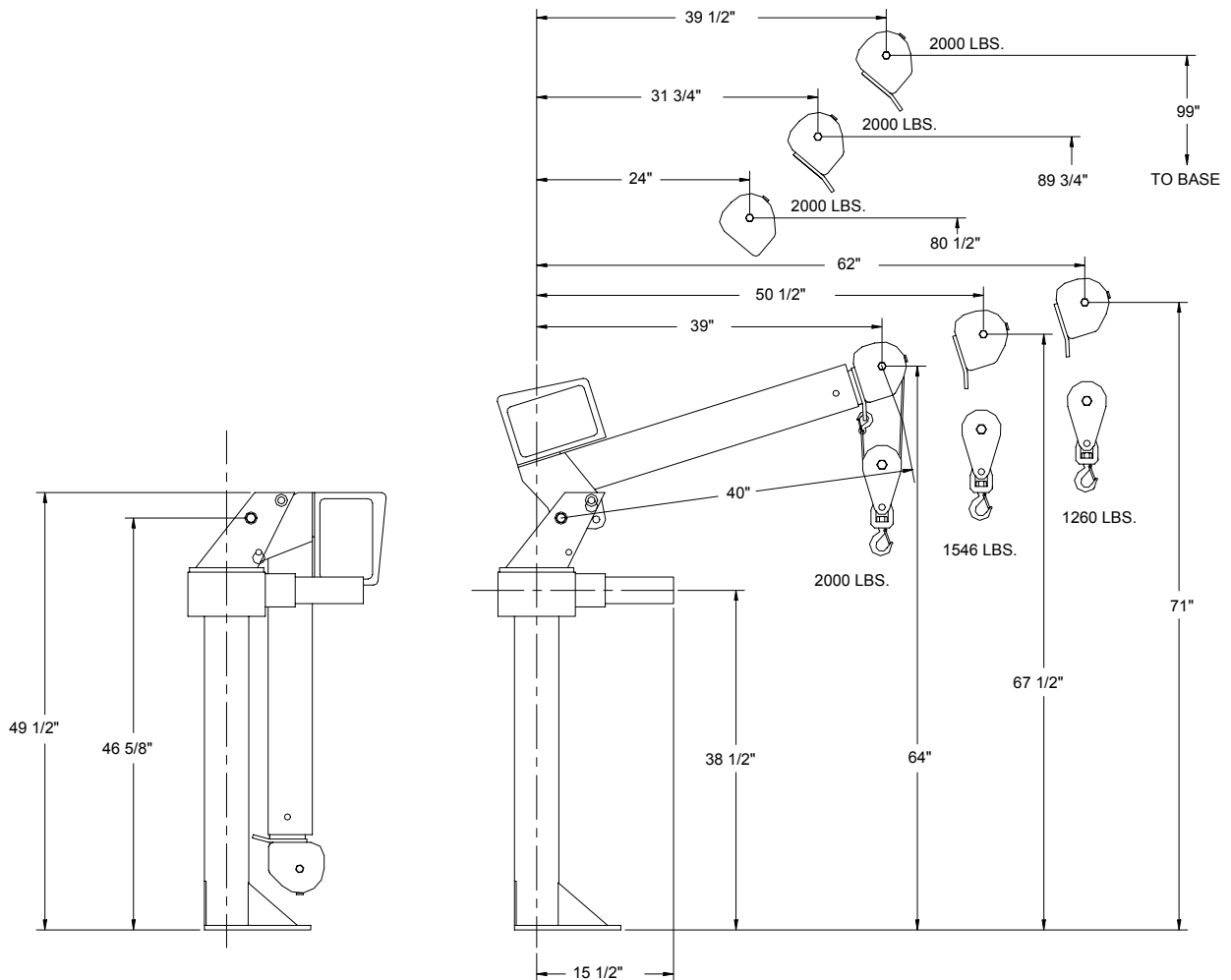
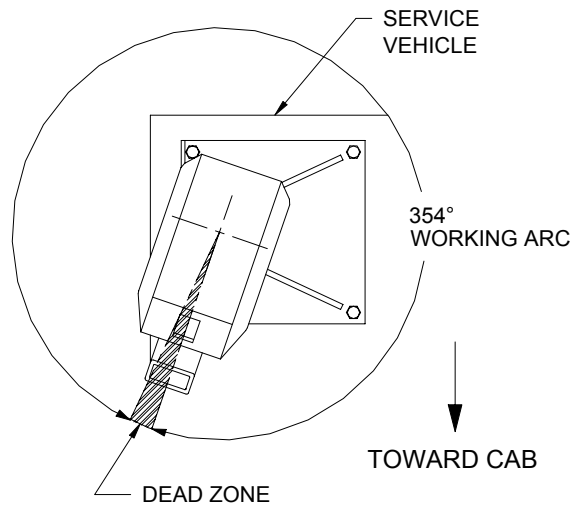
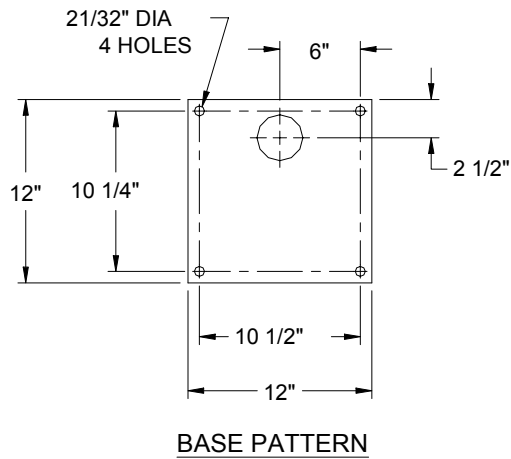

GENERAL DIMENSIONS

ECONO-TON IIR – 7' BOOM

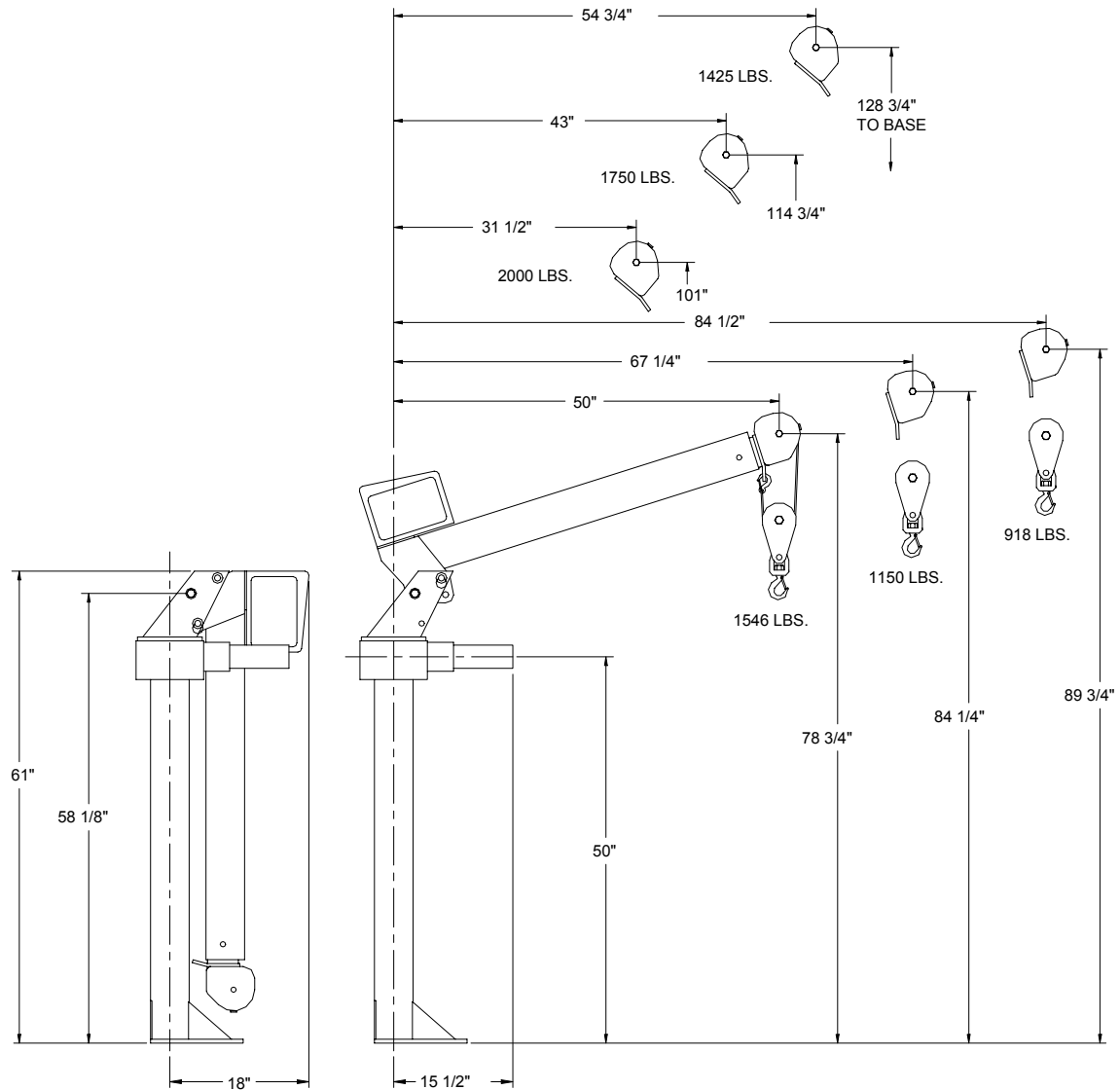
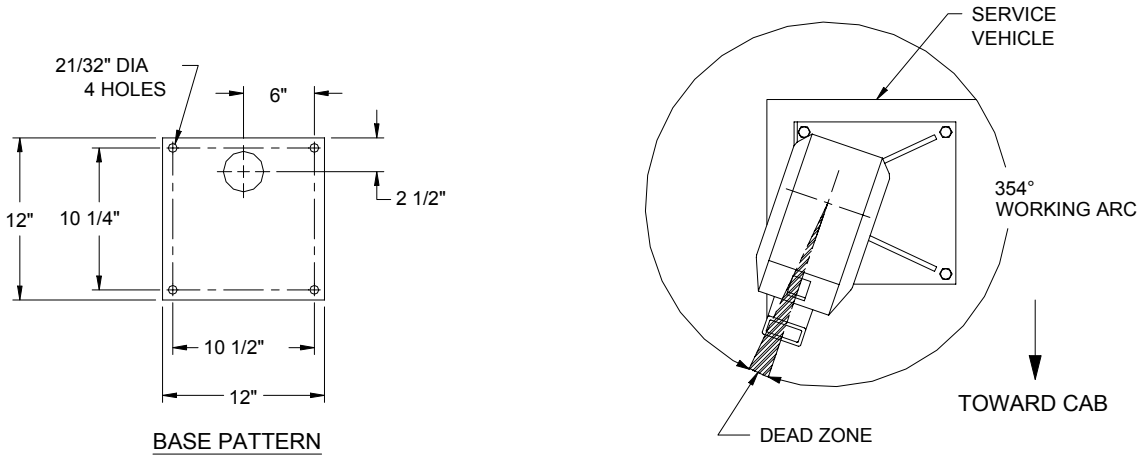

GENERAL ASSEMBLY – ECONO-TON IIR

P/N: 370400200 – 5' BOOM

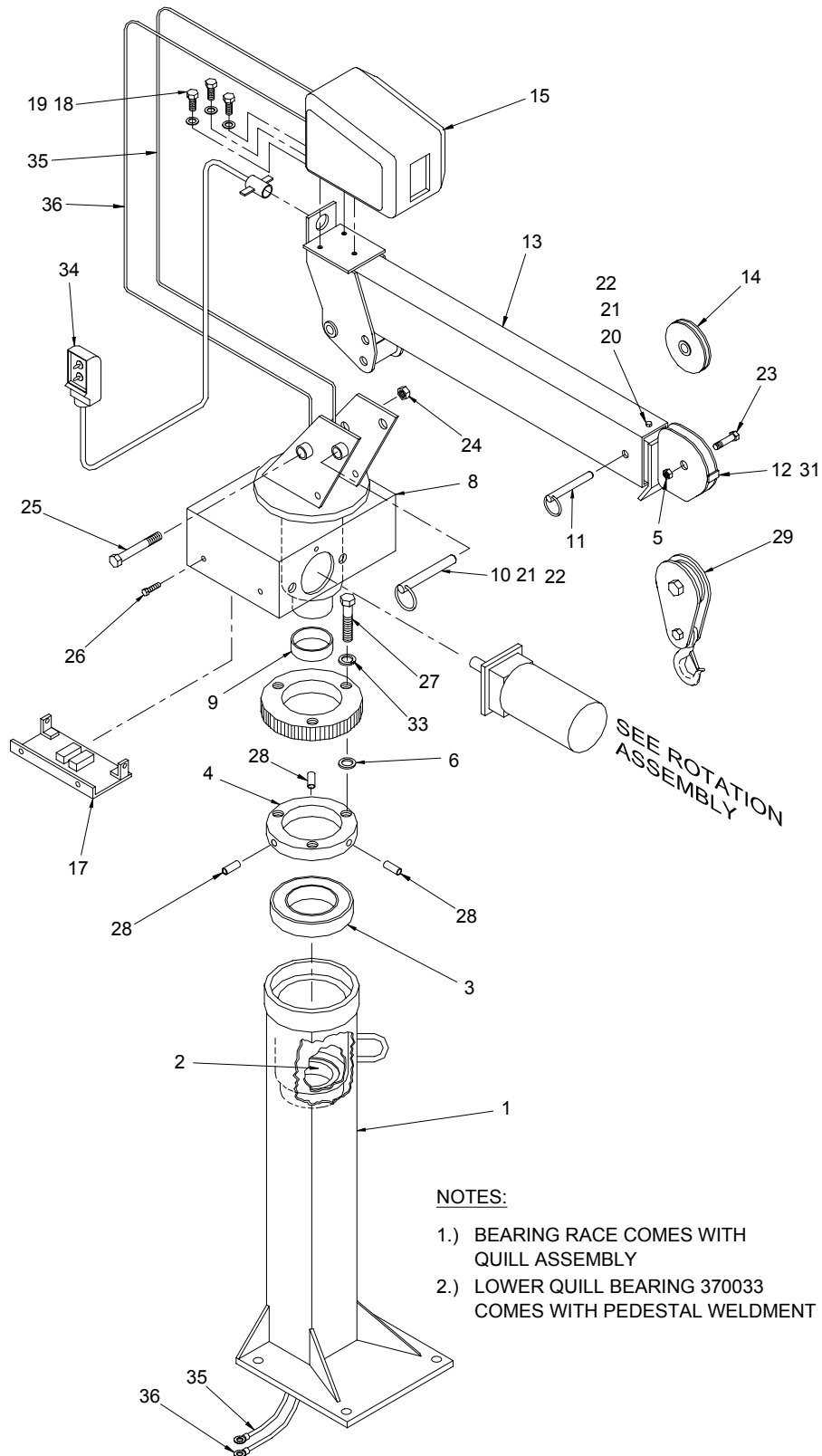

GENERAL ASSEMBLY – ECONO-TON IIR
P/N: 370400200 – 5’ BOOM

ITEM NO.	QTY.	PART NO.	DESCRIPTION
1	1	370491000	PEDESTAL WELDMENT
2	1	370033000	BEARING (SEE NOTE #2)
3	1	330192000	BEARING BALL
4	1	370485000	GEAR SPACER RING
5	1	018100000	NUT LK 5/8 NF
6	A/R	370431000	SHIM
7	1	370418000	WORM GEAR BRONZE
8	1	370487000	QUILL/HOUSING ASSEMBLY
9	1	370034000	BEARING RACE (SEE NOTE #1)
10	1	370001000	LOCK PIN
11	1	370002000	LOCK PIN
12	1	370041000	UPPER BOOM
13	1	370040000	LOWER BOOM
14	1	227401000	SHEAVE ASSEMBLY
15	1	272419000	WINCH ASSEMBLY
16	1	370071000	DECAL KIT
17	1	370490000	LIMIT SWITCH ASSEMBLY
18	3	011510000	SCW HX 1/2 NC X 1 1/4
19	7	021500000	WASHER SP LK 1/2
20	1	370005000	EXTENSION LOCK PAD
21	4	005901000	SCW HX HD 1/4 NC
22	2	020200000	WASHER SP LK 1/4
23	1	012200000	SCW HX HD 5/8 NF
24	1	018600000	NUT LK 3/4 NF
25	1	014302000	SCW HX HD 3/4 NF X 7
26	2	370470000	SCW THRD CUTTER #10-24 X 1/2
27	3	009109000	SCW HX HD 3/8 NC X 1 1/2
28	3	330189000	ROLL PIN 1/4 X 3/4
29	1	100300000	TRAVELING BLOCK
30	1	370436000	RECEPTACLE ASSEMBLY
31	1	370186000	GROMMET
32	3	750737000	TIE WRAPS
33	3	021100000	WASHER SP LK 3/8
34	1	370429000	PENDANT ASSEMBLY
35	1	602005000	POWER CABLE
36	1	602006000	GROUND CABLE

GENERAL ASSEMBLY – ECONO-TON IIR

P/N: 370400300 – 7' BOOM

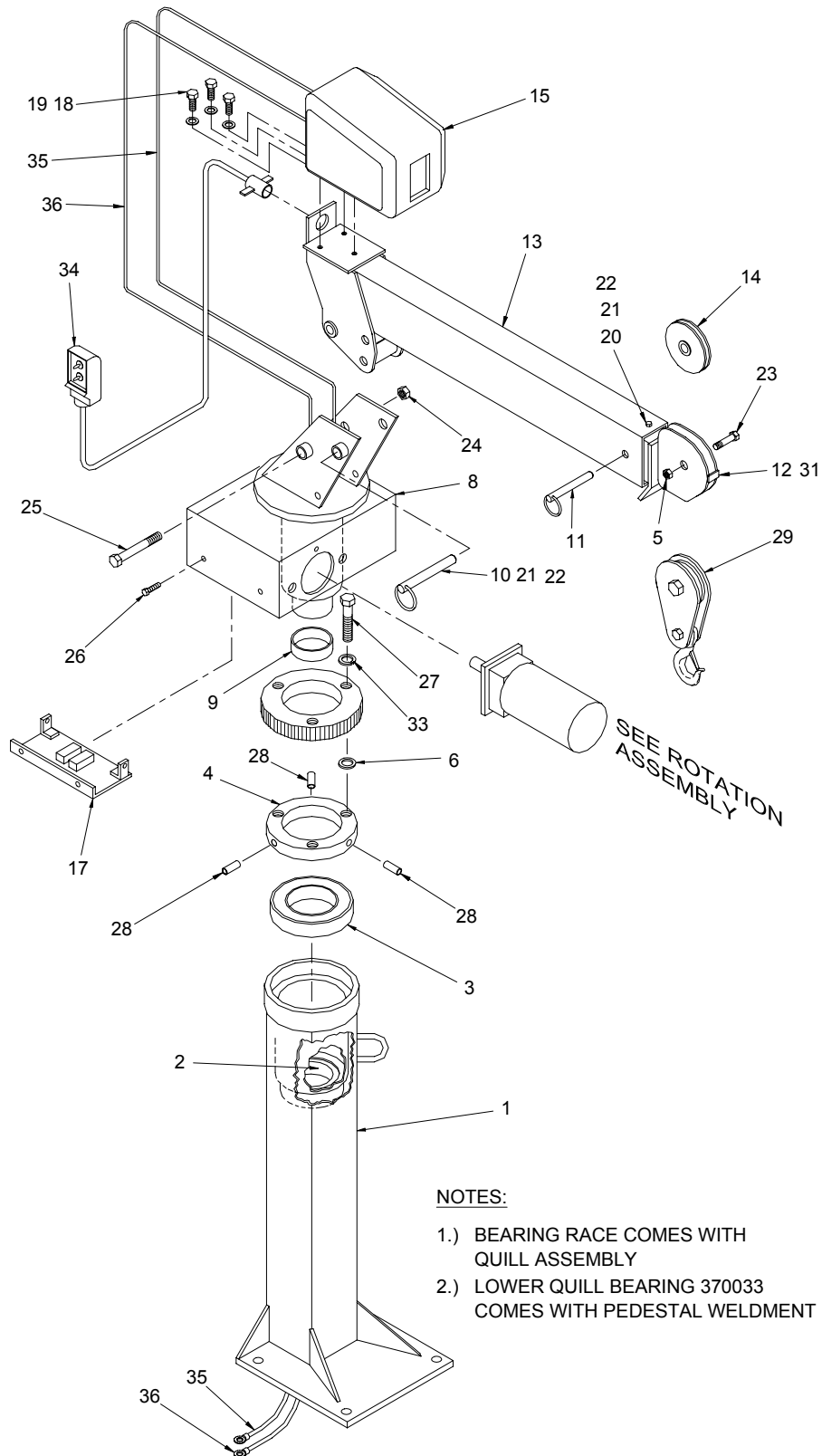

GENERAL ASSEMBLY – ECONO-TON IIR
P/N: 370400300 – 7’ BOOM

ITEM NO.	QTY.	PART NO.	DESCRIPTION
1	1	370491000	PEDESTAL WELDMENT
2	1	370033000	BEARING (SEE NOTE #2)
3	1	330192000	BEARING BALL
4	1	370485000	GEAR SPACER RING
5	1	018100000	NUT LK 5/8 NF
6	A/R	370431000	SHIM
7	1	370418000	WORM GEAR BRONZE
8	1	370487000	QUILL/HOUSING ASSEMBLY
9	1	370034000	BEARING RACE (SEE NOTE #1)
10	1	370001000	LOCK PIN
11	1	370002000	LOCK PIN
12	1	370046000	UPPER BOOM
13	1	370040000	LOWER BOOM
14	1	227401000	SHEAVE ASSEMBLY
15	1	272419000	WINCH ASSEMBLY
16	1	370072000	DECAL KIT
17	1	370490000	LIMIT SWITCH ASSEMBLY
18	3	011510000	SCW HX 1/2 NC X 1 1/4
19	7	021500000	WASHER SP LK 1/2
20	1	370005000	EXTENSION LOCK PAD
21	4	005901000	SCW HX HD 1/4 NC
22	2	020200000	WASHER SP LK 1/4
23	1	012200000	SCW HX HD 5/8 NF
24	1	018600000	NUT LK 3/4 NF
25	1	014302000	SCW HX HD 3/4 NF X 7
26	2	370470000	SCW THRD CUTTER #10-24 X 1/2
27	3	009109000	SCW HX HD 3/8 NC X 1 1/2
28	3	330189000	ROLL PIN 1/4 X 3/4
29	1	100300000	TRAVELING BLOCK
30	1	370436000	RECEPTACLE ASSEMBLY
31	1	370186000	GROMMET
32	3	750737000	TIE WRAPS
33	3	021100000	WASHER SP LK 3/8
34	1	370429000	PENDANT ASSEMBLY
35	1	602005000	POWER CABLE
36	1	602006000	GROUND CABLE

ROTATION ASSEMBLY ECONO-TON IIR

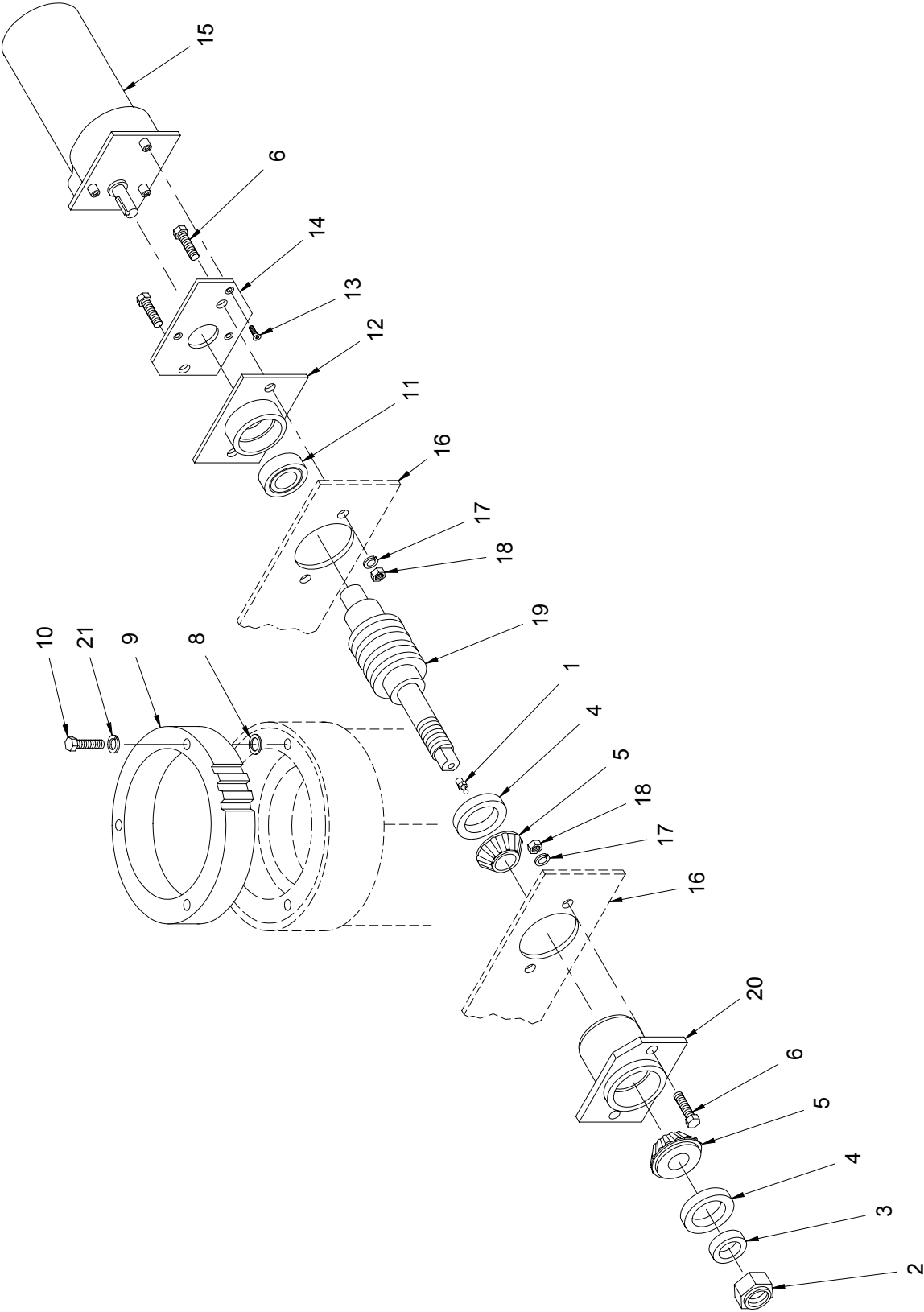

ROTATION ASSEMBLY ECONO-TON IIR

ITEM NO.	QTY.	PART NO.	DESCRIPTION
1	1	239300000	ZERK GREASE
2	1	019000000	NUT HX LK 7/8 NF
3	1	330483000	SPACER
4	2	330486000	OIL SEAL
5	2	330485000	BEARING CONE
6	4	011510000	SCW HX HD 1/2 NC X 1 1/4
7	3	021100000	WASHER SP LK 3/8
8	A/R	370431000	SHIM
9	1	370418000	WORM GEAR BRONZE
10	3	009109000	SCW HX HD 3/8 NC X 1 1/2
11	1	330500000	BEARING (SEE NOTE #1)
12	1	370473000	BEARING HOUSING (SEE NOTE #1)
13	3	330389000	SCW FL HD 1/4 NC X 3/4
14	1	330504000	MOTOR MOUNT
15	1	330313000	MOTOR ELECTRIC
16	1	370487000	HOUSING/QUILL ASEMBLY
17	4	021500000	WASHER SP LK 1/2
18	4	017701000	NUT HX 1/2 NC
19	1	330421000	WORM SHAFT
20	1	330472000	HOUSING BEARING (w/2 BEARING CUPS, 330474)

NOTE:

- ITEM NUMBERS 11 & 12 ARE ORDERED AS AN ASSEMBLY.
P/N: 370474

HIGH SPEED WINCH ASSEMBLY

P/N: 370410000

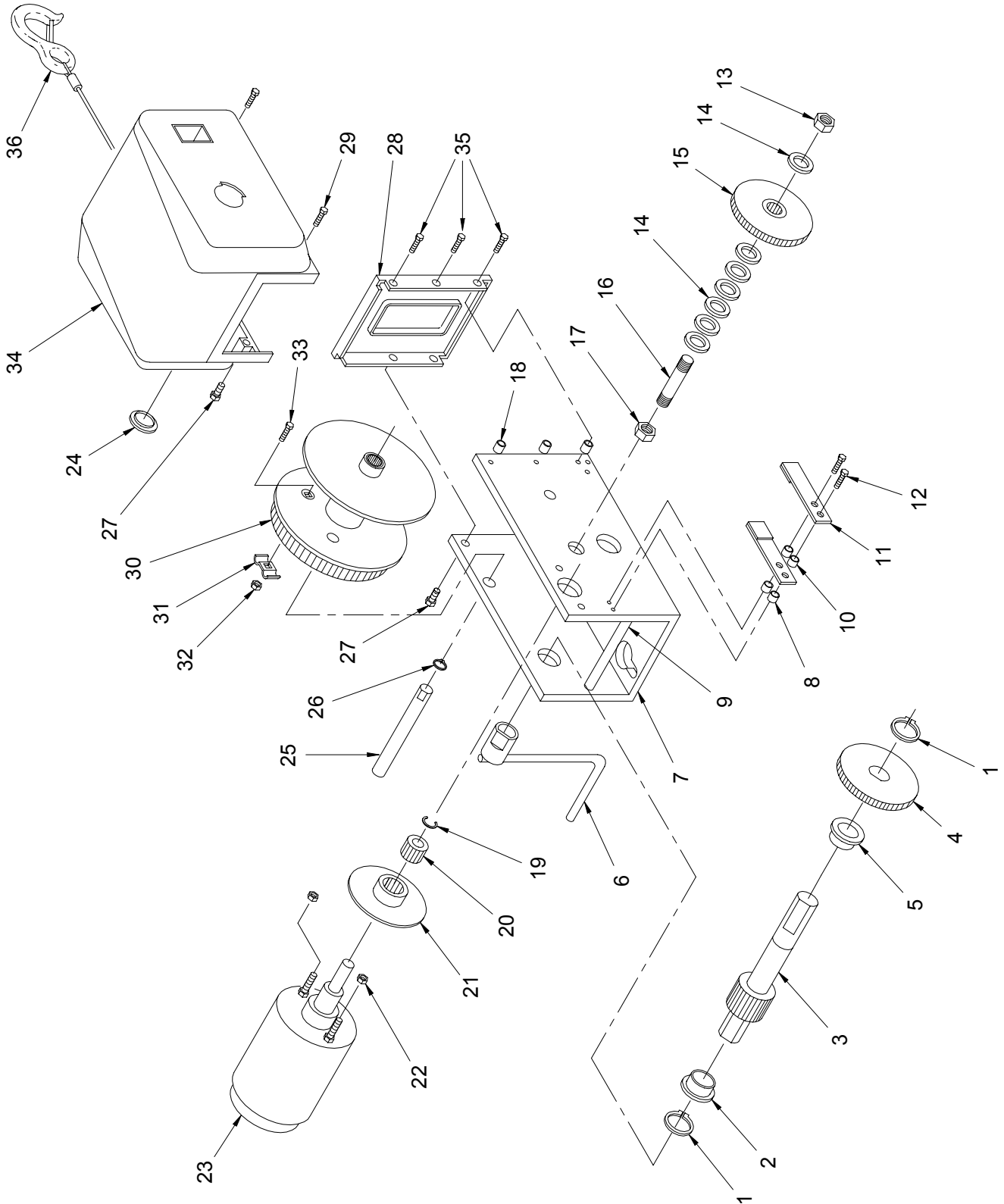

HIGH SPEED WINCH ASSEMBLY

P/N: 370410000

ITEM NO.	QTY.	PART NO.	DESCRIPTION
1	2	272152000	RETAININR RING
2	1	272153000	BUSHING
3	1	370450000	DRIVE SHAFT ASSEMBLY
4	1	370451000	GEAR (56T)
5	1	370467000	BUSHING
6	1	272155000	HANDLE ASSEMBLY
7	1	370452000	BASE
8	2	370453000	SPACER (SEE NOTE)
9	1	370454000	BASE SPACER
10	2	370455000	BRAKE SPRING SPACER (SEE NOTE)
11	2	272434000	BRAKE SPRING ASSEMBLY
12	2	272437000	SCW #10 NF X 1 SELF TAPPING
13	1	330018000	NUT LK 1/2 NC
14	7	272502000	WASHER
15	1	370456000	GEAR (56T)
16	1	330012000	STUD
17	1	330011000	NUT LK 7/16 NF
18	3	370457000	FRONT PLATE SPACER
19	1	272171000	"E" RING
20	1	272170000	MOTOR PINION (22T)
21	1	370458000	BRAKE DISC ASSEMBLY
22	2	330022000	NUT LK #10 NF
23	1	272184000	MOTOR ASSEMBLY (D.C.)
24	1	272508000	COVER PLUG
25	1	370459000	REEL SHAFT
26	1	370460000	RETAINING RING
27	4	272175000	SCW HX HD 1/4 NC X 1/2
28	1	370461000	FRONT PLATE
29	2	370462000	SCW HX HD 1/4 NC X 7/8
30	1	370463000	REEL ASSEMBLY
31	1	272180000	ROPE CLAMP
32	1	272179000	NUT HX 1/4 NC
33	1	370464000	CARRAGE BOLT 1/4 NC
34	1	370465000	COVER
35	3	005500000	SCW HX HD 1/4 NC X 3/4
36	1	370466000	CABLE & HOOK 3/16 X 20'

* ORDER AS BRAKE SPRING KIT P/N: 370468000.

CRANE WIRING ECONO-TON IIR

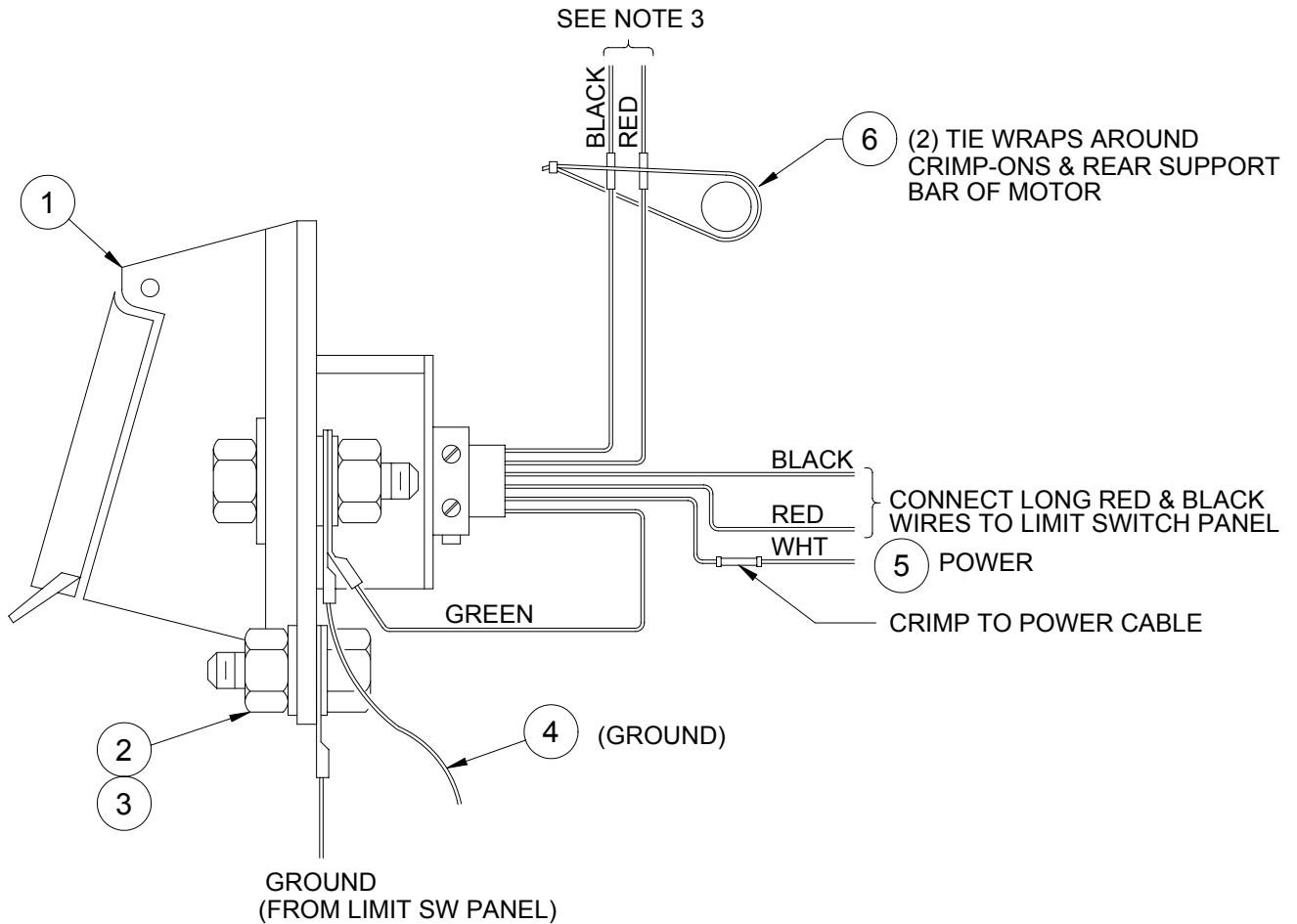

ITEM NO.	QTY.	PART NO.	DESCRIPTION
1	1	370436000	RECEPTACLE ASSEMBLY
2	2	020201000	WASHER INT LK
3	2	015900000	NUT 1/4 NC
4	1	602006000	CABLE GROUND
5	1	602005000	CABLE POWER
6	3	750737000	TIE WRAPS

LIMIT SWITCH PANEL

P/N: 370490000

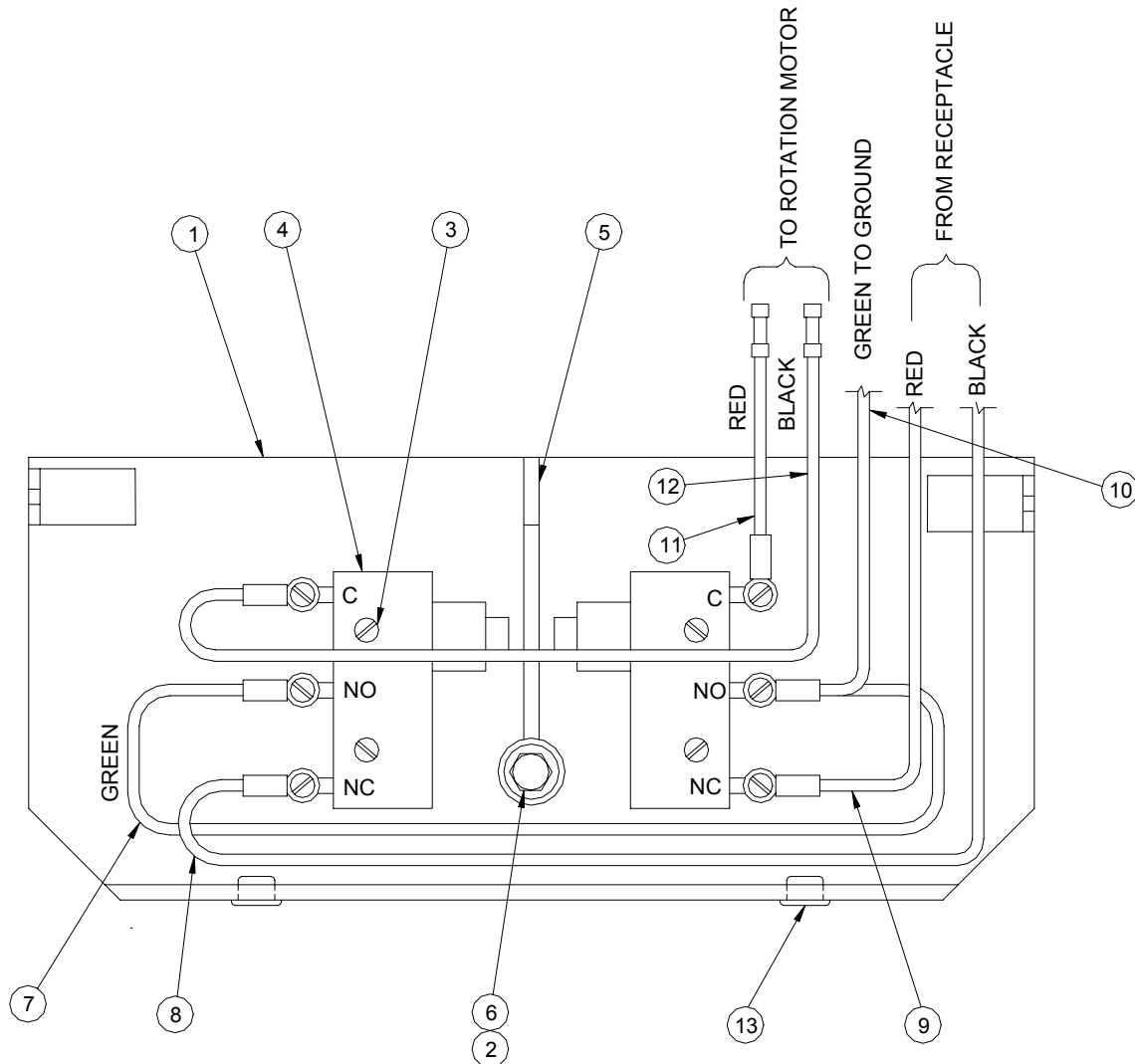

ITEM NO.	QTY.	PART NO.	DESCRIPTION
1	1	370489000	SWITCH PANEL WELDMENT
2	1	015900000	NUT HX 1/4 NC
3	4	000602000	SCW RD HD #6-32 X 1
4	2	370419000	LIMIT SWITCH
5	1	370413000	TRIGGER ASSEMBLY
6	1	005611000	SCW SH 1/4 NC X 1
7	1	370441000	CONDUCTOR ASSEMBLY GREEN
8	1	370442000	CONDUCTOR ASSEMBLY BLACK
9	1	370443000	CONDUCTOR ASSEMBLY RED
10	1	370440000	CONDUCTOR ASSEMBLY GREEN
11	1	370438000	CONDUCTOR ASSEMBLY RED 12 GA
12	1	370437000	CONDUCTOR ASSEMBLY BLACK 12 GA
13	2	736272000	NUT INSEERT 1/4 NC

NOTES

PENDANT ASSEMBLY

P/N: 370429000

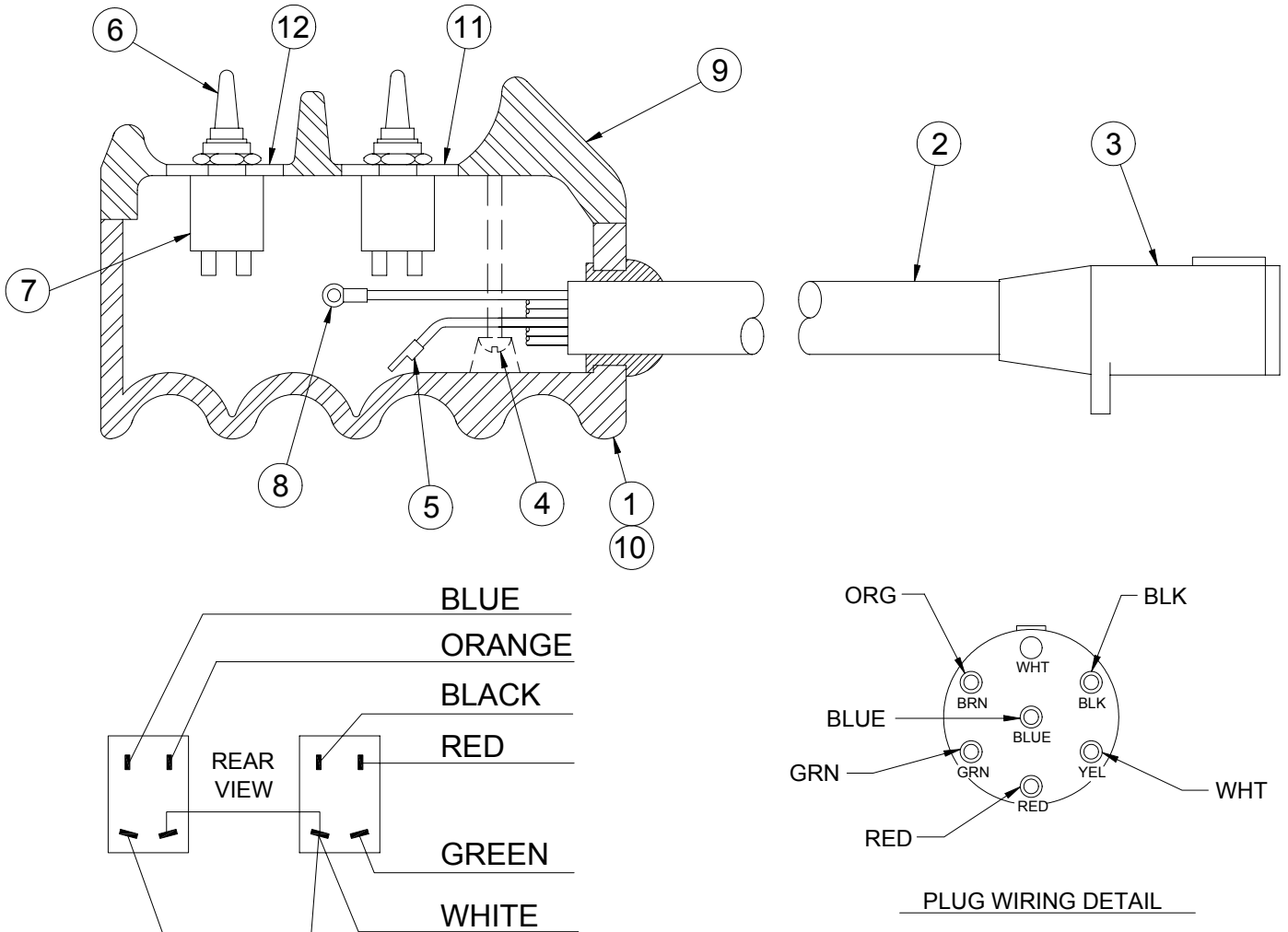

ITEM NO.	QTY.	PART NO.	DESCRIPTION
1	1	370130000	PENDANT HOUSING BOTTOM
2	10'	801005000	CONDUCTOR CABLE (12/6)
3	1	370445000	PLUG PENDANT
4	4	001207000	SCW #8 NC X 1
5	8	000201000	TERMINAL 12 GA
6	2	640300000	BOOT
7	2	370136000	TOGGLE SWITCH
8	2	001002000	TERMINAL - 12 GA (GREEN WIRE ONLY)
9	1	370131000	PENDANT HOUSING TOP
10	1	370132000	PENDANT HOUSING GASKET
11	1	370202000	DECAL HOIST UP/DOWN
12	1	370203000	DECAL ROTATION CW/CCW

LOAD CHART - ECONO-TON IIR

P/N: 370055000

ECONO-TON IIR

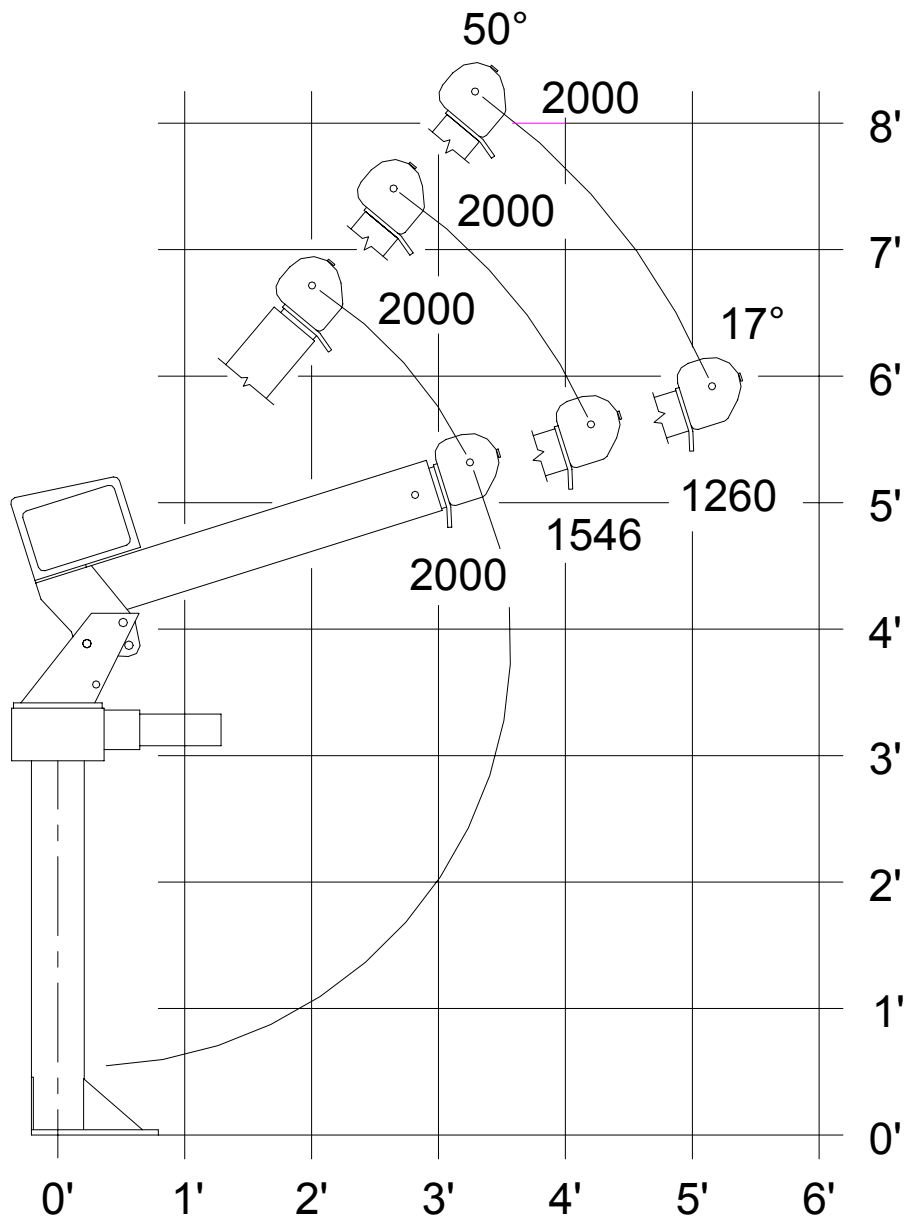

0-1000# SINGLE LINE
1000# -UP DOUBLE LINE

P/N 370055

LOAD CHART - ECONO-TON IIR

P/N: 370057000

ECONO-TON IIR

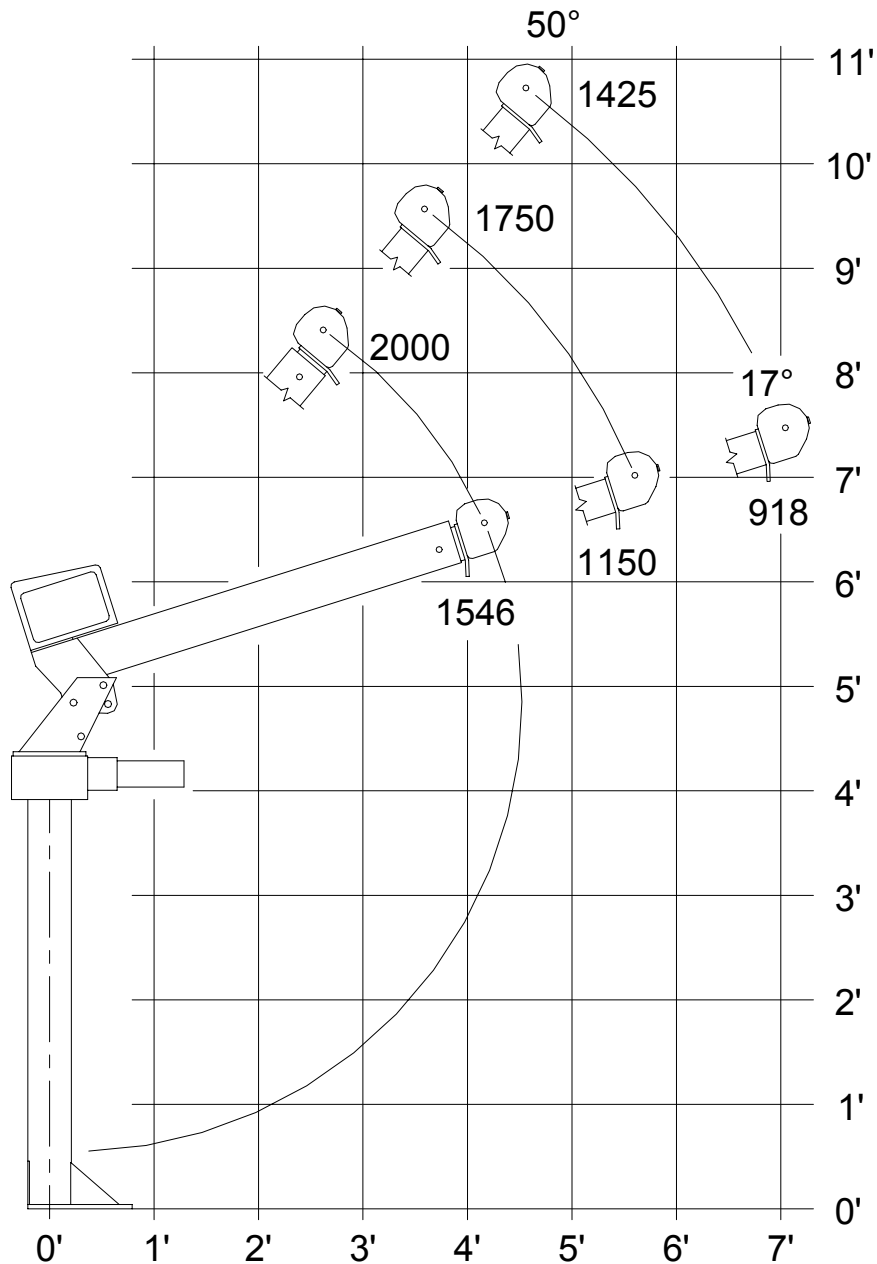

0-1000# SINGLE LINE
1000# -UP DOUBLE LINE

P/N 370057



P.O. Box 580697 * Tulsa, OK 74158-0697
4707 N. Mingo Rd. * Phone (918) 836-0463

LIMITED WARRANTY 2 YEAR PARTS AND LABOR

Auto Crane will warranty to the consumer for a period of (2) years parts and labor from the date of purchase. Each new Auto Crane unit they sell will be free under normal use and service from defects in material and workmanship. Date of purchase will be honored as the date indicated on the Bill of Sale, which must accompany the Warranty Registration and be on file with Auto Crane. Absent a valid Warranty Registration and appropriate documentation, the original date of manufacture, as indicated by the serial number on the product, will be used to determine the effective date of the 2 year warranty.

The obligation of Auto Crane under this warranty is limited to the replacement or repair of parts that appear to the manufacturer after review and/or inspection to be defective and paid flat rate labor for replacing defective parts. This warranty does not obligate Auto Crane to bear the travel time charges in connection with the replacement or repair of defective parts. Responsibility for customer's claims arising from misapplication, abuse, misuse or alteration of equipment or parts lies with the distributor or user and no warranty obligation is assumed in these circumstances by Auto Crane.

Auto Crane will in no event be liable for any consequential damages or contingent liabilities arising out of the failure of any Auto Crane Product or parts to operate properly.

Auto Crane makes no warranty in respect to component accessories, it being subject to the warranties of their respective manufacturers.

If field service, at the request of the distributor, is rendered and fault is found not to be with Auto Crane's product, the distributor shall pay the time and expense of the field representative.

Claims for service labor or other expenses that have incurred by the buyer without approval or authorization or Auto Crane will not be accepted.

When applying for warranty, claims may be handled by contacting your nearest authorized Auto Crane Distributor. All claims are to be filed in writing on an Auto Crane Warranty Claim Form.

AUTO CRANE COMPANY IS UNDER NO OLIGATION TO EXTEND THIS WARRANTY TO ANY CUSTOMER FOR WHICH AN AUTO CRANE DELIVERY REPORT FORM HAS NOT BEEN COMPLETED AND ON FILE WITH AUTO CRANE COMPANY

