



**MODEL RS60AC
AIR COMPRESSOR
OPERATORS, MAINTENANCE
AND PARTS MANUAL**

**OPERATORS, MAINTENANCE, AND PARTS MANUAL
AUTO CRANE MODEL RS60AC**

TABLE OF CONTENTS

Operation & Maintenance Section

Specifications	6
Safety	7
Compressor Terminology	11
Description of Components	12
Inspection, Lubrication, and Maintenance	16
Troubleshooting	24
Compressor Operation	27
Parts and Illustration Section	29
Recommended Spare Parts	36
Service Questionnaire	37
Instructional Procedures for Installation	38

SPECIFICATIONS

DELIVERY @ 150 PSIG	CFM	45	60
Input Speed to Compressor	RPM GPM	1500 10.9 @ 2900 PSI	1950 14.2 @ 2900 PSI
Fluid Capacity-Compressor (not hydraulic)	1.0 Gallons System .75 Compressor Sump		
Components - Compressor System	(Overall Dimensions) see below		
Weight (dry)	300 lbs.		
Maximum Operation Angle	10 °		

SPECIFICATIONS SUBJECT TO CHANGE WITHOUT PRIOR NOTICE

*CALCULATIONS PERFORMED @ 85% EFFICIENCY MECHANICAL AND 96% EFFICIENCY VOLUMETRIC.

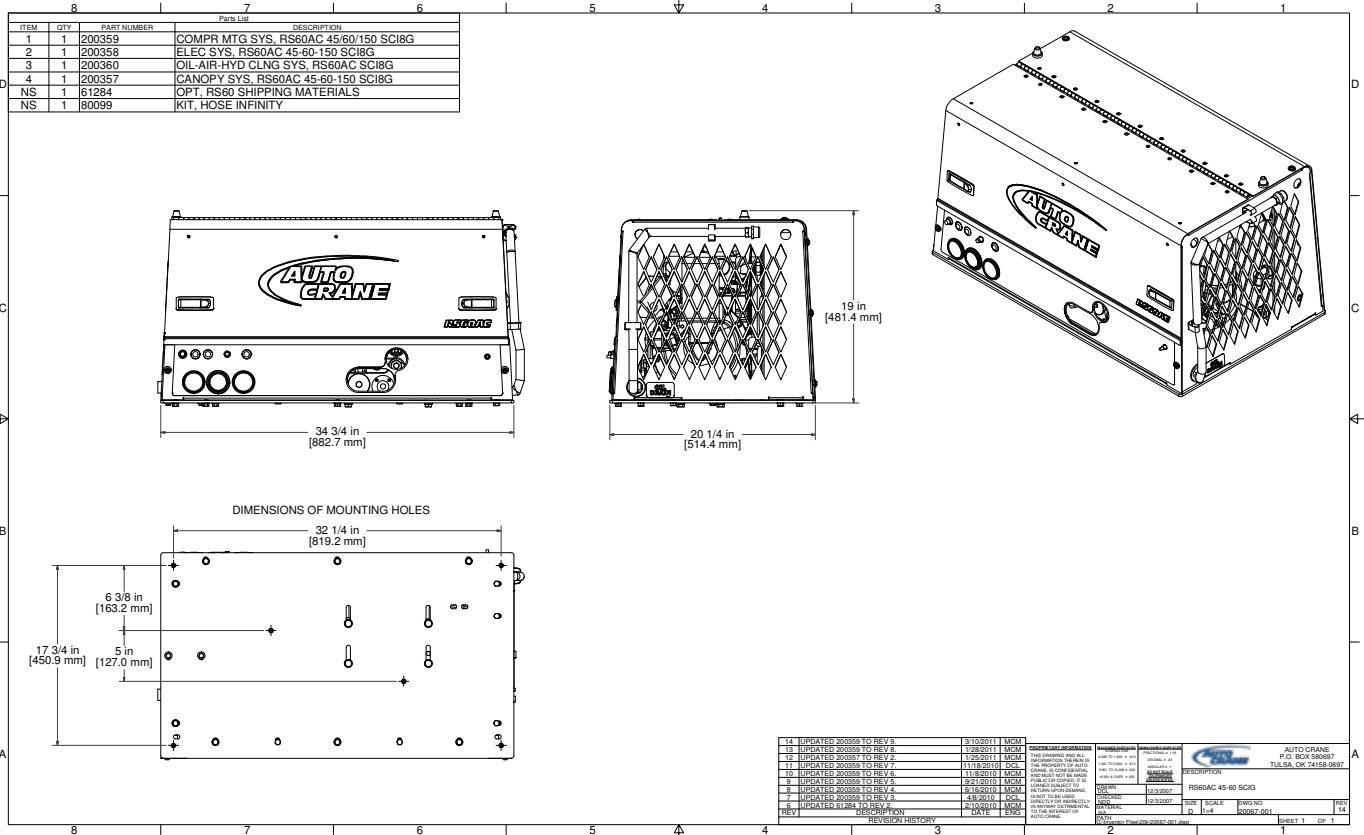

SAFETY

WARNING

ALL UNITS ARE SHIPPED WITH A DETAILED OPERATORS AND PARTS MANUAL. THIS MANUAL CONTAINS VITAL INFORMATION FOR THE SAFE USE AND EFFICIENT OPERATION OF THIS UNIT. CAREFULLY READ THE OPERATORS MANUAL BEFORE STARTING THE UNIT. FAILURE TO ADHERE TO THE INSTRUCTIONS COULD RESULT IN SERIOUS BODILY INJURY OR PROPERTY DAMAGE.

AIR COMPRESSOR SAFETY PRECAUTIONS

Safety is basically common sense. While there are standard safety rules, each situation has its own peculiarities that cannot always be covered by rules. Therefore with your experience and common sense, you are in a position to ensure your safety. Lack of attention to safety can result in: accidents, personal injury, reduction of efficiency and worst of all - Loss of Life. Watch for safety hazards. Correct them promptly. Use the following safety precautions as a general guide to safe operation:

Do not attempt to remove any compressor parts without first relieving the entire system of pressure.

Do not attempt to service any part while machine is operating.

DANGER

CHECK THE COMPRESSOR SUMP OIL LEVEL ONLY WHEN THE COMPRESSOR IS NOT OPERATING AND SYSTEM IS COMPLETELY RELIEVED OF PRESSURE. OPEN SERVICE VALVE TO ENSURE RELIEF OF SYSTEM AIR PRESSURE WHEN PERFORMING MAINTENANCE ON COMPRESSOR AIR/OIL SYSTEM. FAILURE TO COMPLY WITH THIS WARNING MAY CAUSE DAMAGE TO PROPERTY AND SERIOUS BODILY HARM.

Do not operate the compressor at pressure(s) or speed in excess of its rating as indicated in "Compressor Specifications".

Periodically check all safety devices for proper operation.

Do not play with compressed air. Pressurized air can cause serious injury to personnel.

Exercise cleanliness during maintenance and when making repairs by covering parts and exposed openings.

SAFETY

Do not install a shut-off valve between the compressor and compressor oil sump.

DANGER

DO NOT USE AUTO CRANE COMPRESSOR SYSTEMS TO PROVIDE BREATHING AIR. SUCH USAGE, WHETHER SUPPLIED IMMEDIATELY FROM THE COMPRESSOR SOURCE, OR SUPPLIED TO BREATHING TANKS FOR SUBSEQUENT USE, CAN CAUSE SERIOUS BODILY INJURY.

AUTO CRANE DISCLAIMS ANY AND ALL LIABILITIES FOR DAMAGE FOR LOSS DUE TO PERSONAL INJURIES, INCLUDING DEATH, AND/OR PROPERTY DAMAGE INCLUDING CONSEQUENTIAL DAMAGES ARISING OUT OF ANY AUTO CRANE COMPRESSORS USED TO SUPPLY BREATHING AIR.

Do not disconnect or bypass safety circuit system.

Do not install safety devices other than authorized AUTO CRANE replacement devices.

Close all openings and replace all covers and guards before operating compressor unit.

Tools, rags, or loose parts must not be left on the compressor or drive parts.

Do not use flammable solvents for cleaning parts. This can cause the unit to ignite during operation.

Keep combustibles out of and away from the Compressor/Inlet and any associated enclosures.

The owner, lessor, or operator of the Compressor are hereby notified and forewarned that any failure to observe these safety precautions may result in damage or injury.

AUTO CRANE expressly disclaims responsibility or liability for any injury or damage caused by failure to observe these specified precautions or by failure to exercise that ordinary caution and due care required when operating or handling the Compressor, even though not expressly specified above.

SAFETY

A compliment of warning decals is supplied with each unit. These decals must be affixed to the compressor package in the locations noted in this manual. If for any reason a safety decal is removed it is the owners responsibility to make sure it is replaced.



DANGER

DRIVE COUPLING IN
ROTATION DURING
COMPRESSOR OPERATION.
DO NOT RUN COMPRESSOR
WITH CANOPY OFF.

SAFETY

**HYDRAULIC
PRESSURE**

302443

**HYDRAULIC
TANK**

302444

AIR

302445

DIRECTION OF ROTATION

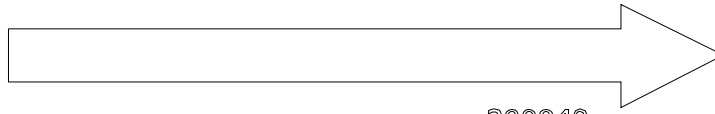

300048



P.O. BOX 580697 TULSA, OK 74158-0697

1-800-815-0198

WWW.AUTOCRANE.COM

SERIAL NO.

305763

COMPRESSOR TERMINOLOGY

AIR/OIL COALESCER - Performs second stage separation of oil from compressed air feeding air tools. Sometimes referred to as the separator element.

CFM - Refers to the volume of compressed air being produced, expressed as cubic feet of air per minute.

COMPRESSOR LUBRICANT - DEXTRON III ATF.

GPM - Refers to the amount of gallons per minute of hydraulic fluid flowing through the pump.

OIL SUMP - The first stage of oil separation from compressed air. Also serves as reservoir area for compressor lubricant and sometimes referred to as the receiver tank.

PSI - Refers to the operating pressure the system is set up at, expressed as pounds per square inch.

SAFETY VALVE - A valve located on the oil sump which opens in case of excessive pressure. Sometimes referred to as the pop-off or pressure relief valve.

DESCRIPTION OF COMPONENTS

COMPRESSOR ASSEMBLY

The AUTO CRANE hydraulic drive compressor assembly is a positive displacement, oil flooded, rotary screw type unit employing one stage of compression to achieve the desired pressure. Components include a housing (stator), two screws (rotors), bearings, and bearing supports. Power from the hydraulic motor shaft is transferred to the male rotor through a drive coupling. The female rotor is driven by the male rotor. There are five lobes on the male rotor while the female rotor has six roots.

PRINCIPLES OF OPERATION

In operation, two helical grooved rotors mesh to compress air. Inlet air is trapped as the male lobes roll down the female grooves, pushing trapped air along, compressing it until it reaches the discharge port in the end of the stator and delivers smooth-flowing, pulse-free air to the receiver.

During the compression cycle, oil is injected into the compressor and serves these purposes:

1. Lubricates the rotating parts and bearings.
2. Serves as a cooling agent for the compressed air.
3. Seals the running clearances.

LUBRICATION SYSTEM

Oil from the compressor at discharge pressure, is directed into its integral housing, through the thermal valve and filter, and then out of the integral housing to the oil cooling system, and then back to the side of the compressor stator, where it is injected into the compressor. At the same time oil is directed internally to the bearings and shaft seal of the compressor.

OIL SUMP

Compressed, oil-laden air enters the sump from the compressor. As the oil-laden air enters the sump, most of the oil is separated from the air as it passes through a series of baffles and diffusion plates. The oil accumulates at the bottom of the sump for recirculation. However, some small droplets of oil remain suspended in the air and are passed on to the Coalescer.

SAFETY VALVE

The pop safety valve is set at 200 PSI and is located at the top of the air/oil sump. This valve acts as a backup to protect the system from excessive pressure that might result from a malfunction.

DESCRIPTION OF COMPONENTS

AIR/OIL COALESCER

The coalescer is self-contained within a spin-on housing. When air is demanded at the service line, it passes through the coalescer which efficiently provides the final stage of oil separation.

OIL RETURN LINE

The oil that is removed by the coalescer accumulates and is returned through an internal oil return line leading to the compressor.

MINIMUM PRESSURE VALVE

The minimum pressure valve is located at the outlet of the coalescer head and serves to maintain a minimum discharge pressure of 75 PSIG in operation, which is required to assure adequate compressor lubrication pressure.

OIL FILTER

The compressor oil filter is a removable and cleanable screen built into the side of the compressor housing. Screen replacement may be necessary after several cleanings.

COMPRESSOR OIL COOLING SYSTEM

The compressor cooling system consists of a combination hydraulic cooler and compressor cooler mounted on the common frame. Compressor oil temperature is controlled by a thermal valve located down stream of the oil filter. The thermal valve maintains the compressor oil temperature at 185°F. Cool air is drawn through the vented end panel and across the combo cooler. The air is heated by the coolers and the hot air exits out the back vented panel . Allow for adequate clearance (12") for the air to exit. Also, the package location should not be subjected to above ambient air temperatures.

HYDRAULIC COOLING SYSTEM

The machine is equipped with an integrated hydraulic cooler that is effective up to 90°F ambient temperature. If running at a higher ambient temperature, an additional hydraulic cooler is required. The system cooler is not designed for any additional heat load created from auxiliary components.

For hydraulic cooler recommendations, please contact your local Auto Crane distributor.

DESCRIPTION OF COMPONENTS

INSTRUMENTATION

The AUTO CRANE hydraulic drive compressor unit incorporates a gauge panel that monitors temperature, pressure and hours of operation.

HOURMETER

The hourmeter records the total number of operating hours. It serves as a guide in following the recommended inspection and maintenance schedule. The hourmeter will only run when there is pressure in the system.

COMPRESSOR DISCHARGE AIR/OIL TEMPERATURE SWITCHGAUGE

This switchgauge indicates compressor air discharge temperature. The switchgauge ensures safety shutdown in case of excessive operating temperatures, preventing compressor damage, by stopping hydraulic flow to the compressor motor.

ELECTRICAL AND SAFETY SYSTEM

The AUTO CRANE compressor's standard electrical system consists of:

- Gauge panel with a temperature switchgauge, hourmeter and discharge pressure switchgauge.
- Compressor and hydraulic oil cooler fan assembly and relay.
- Compressor after cooler/oil cooler fan assembly and relay.
- 3-way pressure switch and relay to control hourmeter and blowdown.
- 12VDC N.O. hydraulic solenoid and relay.
- Switch relay for customer equipment interface during compressor operation.
- Differential pressure switch for air filter maintenance.
- Optical oil level switch and relay.

DESCRIPTION OF COMPONENTS

CONTROL SYSTEM

The prime component of the compressor control system is the compressor inlet valve. The control system is designed to match air supply to air demand and to prevent excessive discharge pressure when compressor is at idle. Control of air delivery is accomplished by the inlet valve regulation and modulation as directed by the discharge pressure regulator.

NORMALLY OPEN REGULATOR SOLENOID

A closed Furnas air pressure switch will energize the normally open regulator solenoid, thus closing it. When the normally open regulator solenoid is closed, air pressure will rise. When it is open air pressure falls only in the compressor sump.

NOTE: Most air tools operating pressure range is between 90 and 125 psi. Operating above the tools recommended pressures will decrease the life of the tool. Higher operating pressure can also over torque nuts and bolts fatiguing the fastener and mating parts. Strictly adhere to tool operating pressures and torque standards set forth by the tool manufacturer and the specifications of the equipment that work is being performed on.

FURNAS SWITCH DESCRIPTION

The Furnas switch is a N.C. electrical switch set to open at 150 PSI and set to close at 115 PSI. The Furnas switch controls the N.O. regulator solenoid. If service air pressure is under 150 PSI, the Furnas switch will not trip keeping the N.O. inlet valve open and the compressor making air. If the service valve is closed or the tool using the air is off, service line pressure will rise over 150 PSI. This will trip the Furnas switch to open. The regulator solenoid will open and send air pressure to the inlet valve to close. With the inlet valve closed, the compressor will stop making air. If the tool is turned on or the service valve is opened, the service line pressure will drop. When the pressure falls to 115 PSI the Furnas switch will close energizing the N.O. regulator solenoid closing off the air supply to the inlet valve. This will allow the inlet valve to open, and the compressor will start making air to meet the demand.

INLET VALVE

The compressor inlet valve is a piston operated disc valve that regulates the inlet opening to control capacity and serves as a check valve at shutdown.

INSPECTION, LUBRICATION, AND MAINTENANCE

This section contains instructions for performing the inspection, lubrication, and maintenance procedures required to maintain the compressor in proper operating condition. The importance of performing the maintenance described herein cannot be over emphasized.

The periodic maintenance procedures to be performed on the equipment covered by this manual are listed below. It should be understood that the intervals between inspections specified are maximum interval. More frequent inspections should be made if the unit is operating in a dusty environment, in high ambient temperature, or in other unusual conditions. A planned program of periodic inspection and maintenance will help avoid premature failure and costly repairs. Daily visual inspections should become a routine.

The LUBRICATION AND MAINTENANCE CHART lists serviceable items on this compressor package. The items are listed according to their frequency of maintenance, followed by those items which need only “As Required” maintenance.

The maintenance time intervals are expressed in hours. The hourmeter shows the total number of hours your compressor has run. Use the hourmeter readings for determining your maintenance schedules. Perform the maintenance at multiple intervals of the hours shown. For example, when the hourmeter shows “100” on the dial, all items listed under “EVERY 10 HOURS” should be serviced for the tenth time, and all items under “EVERY 50 HOURS” should be serviced for the second time, and so on.

DANGER

COMPRESSOR MUST BE SHUT DOWN AND COMPLETELY RELIEVED OF PRESSURE PRIOR TO CHECKING FLUID LEVELS. OPEN SERVICE VALVE TO ENSURE RELIEF OF SYSTEM AIR PRESSURE. FAILURE TO COMPLY WITH THIS WARNING MAY CAUSE DAMAGE TO PROPERTY AND SERIOUS BODILY HARM.

LUBRICATION AND MAINTENANCE CHART

INTERVAL	ACTION
PERIODICALLY DURING OPERATION	<ol style="list-style-type: none"> 1. Observe all gauge readings. Note any change from the normal readings and determine the cause. Have necessary repairs made. (NOTE: "NORMAL" is the usual gauge reading when operating at similar conditions on a day to day basis.)
DAILY	<ol style="list-style-type: none"> 1. Check the compressor oil level. 2. Check air filter. Pressure drop indicator while compressor is operating. 3. Check for oil and air leaks. 4. Check safety circuit switches.
EVERY 25 HOURS OR MONTHLY	<ol style="list-style-type: none"> 1. Drain water from compressor oil.
EVERY 500 HOURS OR 6 MONTHS	<ol style="list-style-type: none"> 1. Change compressor oil and replace screen 2. Check compressor shaft seal for leakage. 3. Check air filter piping, fittings and clamps. 4. Check compressor supports. 5. Install new air filter element. (Shorter interval may be necessary under dusty conditions.) 6. Check sump safety valve.
EVERY 1000 HOURS OR 1 YEAR	<ol style="list-style-type: none"> 1. Change coalescing element.
PERIODICALLY OR AS REQUIRED	<ol style="list-style-type: none"> 1. Inspect and clean air filter element. 2. Inspect and replace spin-on coalescer element if necessary. 3. Inspect and clean oil cooler fins.

NOTE: Compressor oil and filter is to be changed after the first 50 hours of operation. After this, normal intervals are to be followed.

LUBRICANT RECOMMENDATIONS

WARNING

IT IS IMPORTANT THAT THE COMPRESSOR OIL BE OF A RECOMMENDED TYPE AND THAT THIS OIL AS WELL AS THE AIR FILTER, OIL FILTER, AND COALESCER ELEMENTS BE INSPECTED AND REPLACED AS STATED IN THIS MANUAL.

THE COMBINATION OF A COALESCER ELEMENT LOADED WITH DIRT AND OXIDIZED OIL PRODUCTS TOGETHER WITH INCREASED AIR VELOCITY AS A RESULT OF THIS CLOGGED CONDITION MAY PRODUCE A CRITICAL POINT WHILE THE MACHINE IS IN OPERATION WHERE IGNITION CAN TAKE PLACE AND COULD CAUSE A FIRE IN THE OIL SUMP.

FAILURE TO COMPLY WITH THIS WARNING MAY CAUSE DAMAGE TO PROPERTY AND SERIOUS BODILY HARM.

The following are general characteristics for a rotary screw lubricant. Due to the impossibility of establishing limits on all physical and chemical properties of lubricants which can affect their performance in the compressor over a broad range of environmental influences, the responsibility for recommending and consistently furnishing a suitable heavy duty lubricant must rest with the individual supplier if they choose not to use the recommended AUTO CRANE rotary screw lubricant. The lubricant supplier's recommendation must, therefore, be based upon not only the following general characteristics, but also upon his own knowledge of the suitability of the recommended lubricant in helical screw type air compressors operating in the particular environment involved.

CAUTION

MIXING DIFFERENT TYPES OR BRANDS OF LUBRICANTS IS NOT RECOMMENDED DUE TO THE POSSIBILITY OF A DILUTION OF THE ADDITIVES OR A REACTION BETWEEN ADDITIVES OF DIFFERENT TYPES.

LUBRICANT RECOMMENDATIONS

LUBRICANT CHARACTERISTICS

1. Flash point 400°F minimum.
2. Pour point -40°F.
3. Contains rust and corrosion inhibitors.
4. Contains foam suppressors.
5. Contains oxidation stabilizer.

NOTE

DUE TO ENVIRONMENTAL FACTORS THE USEFUL LIFE OF ALL “EXTENDED LIFE” LUBRICANTS MAY BE SHORTER THAN QUOTED BY THE LUBRICANT SUPPLIER. AUTO CRANE ENCOURAGES THE USER TO CLOSELY MONITOR THE LUBRICANT CONDITION AND TO PARTICIPATE IN AN OIL ANALYSIS PROGRAM WITH THE SUPPLIER.

NOTE

NO LUBRICANT, HOWEVER GOOD AND/OR EXPENSIVE, CAN REPLACE PROPER MAINTENANCE AND ATTENTION. SELECT AND USE IT WISELY.

MAINTENANCE

If some of the maintenance intervals in the schedule outlined in this manual seem to be rather short, it should be considered that one hour's operation of a compressor is equal to about 40 road miles on an engine. Thus, eight hours operation is equal to 320 road miles, 250 hours is equal to 10,000 road miles, etc.

COMPRESSOR OIL SUMP FILL, LEVEL, AND DRAIN

Before adding or changing compressor oil make sure that the compressor is completely relieved of pressure. Oil is added at the fill cap on the side of the compressor body. A drain valve/hose assembly is provided at the bottom of the compressor body. The proper oil level is between the top and the midpoint of the oil sightglass, when the unit is shut down and has had time to settle. The truck must be level when checking the oil. **DO NOT OVERFILL.** The oil sump capacity is given in "Compressor Specifications".

DANGER

DO NOT ATTEMPT TO DRAIN CONDENSATE, REMOVE THE OIL LEVEL FILL PLUG, OR BREAK ANY CONNECTION IN THE AIR OR OIL SYSTEM WITHOUT SHUTTING OFF COMPRESSOR AND MANUALLY RELIEVING PRESSURE FROM THE SUMP. FAILURE TO COMPLY WITH THIS WARNING MAY CAUSE DAMAGE TO PROPERTY AND SERIOUS BODILY HARM.

WARNING

IF COMPRESSOR IS NOT OPERATED AT FULL SYSTEM TEMPERATURE (170°F) WEEKLY, COMPRESSOR OIL SHOULD BE CHANGED MONTHLY.

AIR INTAKE FILTER

The air intake filter is a heavy-duty dry type high efficiency filter designed to protect the compressor from dust and foreign objects. Optional two-stage available.

Optional filter is equipped with an evacuator cup for continuous dust ejection while operating and when stopped.

Frequency of maintenance of the filter depends on dust conditions at the operating site. The filter element must be serviced when clogged (maximum pressure drop for proper operation is 15" of water). The filter is equipped with a pressure drop indicator, and the element should be changed based on its reading first and then by the maintenance intervals outlined.

MAINTENANCE

AIR/OIL COALESCER

The air/oil coalescer employs an element permanently housed within a spin-on canister. This is a single piece unit that requires replacement when it fails to remove the oil from the discharge air, or pressure drop across it exceeds 15 PSI. Dirty oil clogs the element and increases the pressure drop across it.

To replace element proceed as follows:

1. Shutdown compressor and wait for complete blow down (zero pressure).
2. Turn element counterclockwise for removal (viewing element from bottom).
3. Apply a film of fluid directly to seal on the new element.
4. Rotate element clockwise by hand until element contacts seal (viewing element from bottom).
5. Rotate element approximately one more turn clockwise with band wrench near the top of element.
6. Run system and check for leaks.

WARNING

DO NOT SUBSTITUTE ELEMENT. USE ONLY A GENUINE AUTO CRANE REPLACEMENT ELEMENT. THIS ELEMENT IS RATED AT 200 PSI WORKING PRESSURE. USE OF ANY OTHER ELEMENT MAY BE HAZARDOUS AND COULD IMPAIR THE PERFORMANCE AND RELIABILITY OF THE COMPRESSOR, POSSIBLY VOIDING THE WARRANTY AND/OR RESULTING IN DAMAGE TO PROPERTY AND SERIOUS BODILY HARM.

COALESCER OIL RETURN

This originates at the bottom of the air/oil coalescer and flows through a special recovery pipe and venturi nozzle. If the coalescer starts to fill with oil there is a good chance the venturi or pipe has been plugged. Consult factory for cleaning instructions.

MAINTENANCE

OIL FILTER

The compressor oil filter is a throwaway type cartridge. It is designed with a built-in bypass so that if there is a large restriction, due to cold oil or clogged element, the compressor will still be lubricated.

To replace filter proceed as follows:

1. Make sure system pressure is relieved.
2. Unscrew with 14mm allen wrench.
3. Remove oil filter from housing.
4. Replace the oil filter screen element.
5. Reinsert oil filter screen into housing and tighten with 14mm allen wrench.
6. Add oil (total system takes one gallon), re-tighten filler cap.
7. Check for leaks in operation.

WARNING

DO NOT SUBSTITUTE ELEMENT. USE ONLY A GENUINE AUTO CRANE REPLACEMENT ELEMENT. USE OF ANY OTHER ELEMENT MAY BE HAZARDOUS AND COULD IMPAIR THE PERFORMANCE AND RELIABILITY OF THE COMPRESSOR, POSSIBLY VOIDING THE WARRANTY AND/OR RESULTING IN DAMAGE TO PROPERTY AND SERIOUS BODILY HARM.

HYDRAULIC OIL COOLER AND COMPRESSOR OIL COOLER COMBINATION

The interior of the oil cooler should be cleaned when the pressure drop across it at full flow exceeds 25 PSI. The following procedure has been recommended by the vendor who supplies the cooler:

1. Remove cooler.
2. Circulate a suitable solvent to dissolve and remove varnish and sludge.
3. Flush generously with compressor lubricant (compressor oil cooler section only, use hydraulic oil to flush the hydraulic cooler portion on the combo cooler).
4. Once the coolers are reinstalled, fill the compressor and hydraulic systems with the proper fluids to their appropriate levels.

MAINTENANCE

SHAFT SEAL

SHAFT SEAL INSTALLATION INSTRUCTIONS:

1. Remove hydraulic motor, drive coupling and adapter housing from face of compressor.
2. Remove coupling hub from compressor shaft.
3. Remove 4 screws from shaft seal cover and press seal out.
4. Pull seal wear sleeve off shaft with puller.
5. Clean shaft surface removing all burrs from shaft where the wear sleeve gets installed.
6. Press new wear sleeve on to shaft. Oil heating new wear sleeve to 212°F approximately aids in the installation of this ring.
7. Press new seal into housing with seal assembly tool, until contact with snapping.
8. Temporarily install new seal installation cone over shaft to protect seal during reinstallation.
9. Reinstall cover.
10. Reinstall coupling hub to compressor shaft.
11. Reinstall adapter housing, drive coupling, and hydraulic motor to face of compressor.

TROUBLESHOOTING

This section contains instructions for troubleshooting the equipment following a malfunction.

The troubleshooting procedures to be performed on the equipment are listed below. Each symptom of trouble for a component or system is followed by a list of probable causes of the trouble and suggested procedures to be followed to identify the cause.

In general, the procedures listed should be performed in the order in which they are listed, although the order may be varied if the need is indicated by conditions under which the trouble occurred. In any event, the procedures which can be performed in the least amount of time and with the least amount of removal or disassembly of parts, should be performed first.

UNPLANNED SHUTDOWN

When the operation of the machine has been interrupted by an unexplained shutdown, check the following:

1. Check the fuel level and truck dash gauges and indications for possible engine problems.
2. Check the compressor discharge temperature/switchgauge. If the latching relay circuit is tripped the 12VDC solenoid will lose power and divert hydraulic oil back to the reservoir. The compressor blowdown pressure switch and the temperature switchgauge will not allow power to the hydraulic solenoid until the air has blown down and the temperature has dropped into its normal operating range and the push button has been reset. Take compressor in for service once a high temperature shutdown has occurred. Failure to do so will void your warranty.
3. Check that the compressor oil is at proper level.
4. Check oil cooler for dirt, slush, ice on the fins, or any other obstructions to the cooling air flow.
5. Make a thorough external check for any cause of shutdown such as broken hose, broken oil lines, loose or broken wire, etc.

TROUBLESHOOTING

IMPROPER DISCHARGE PRESSURE

1. If discharge pressure is too low, check the following:
 - A. Too much air demand. (Air tools require more air than what the compressor can produce, air tools are free wheeling without resistance.)
 - B. Service valve wide open to atmosphere.
 - C. Leaks in service line.
 - D. Restricted compressor inlet air filter.
 - E. Faulty control system operation (i.e.N.O. regulated air solenoid is allowing air through all the time.)
 - F. Furnas Switch is not closing at 115 psi.
 - G. Low compressor oil level.
2. If discharge pressure is too high, safety valve blows, or system shuts down on high pressure, check the following:
 - A. Faulty discharge pressure switchgauge.
 - B. Coalescer plugged up.
 - C. Faulty safety valve.
 - D. N.O. regulated air solenoid is not opening.
 - E. Furnas switch is not opening at 150 psi.
3. Sump relief valve activates:
 - A. Inlet valve leaking or open.
 - B. Faulty relief valve.
 - C. Faulty Furnas switch, or N.O. regulated air solenoid, or pressure switchgauge.

SUMP PRESSURE DOES NOT BLOW DOWN

If after the compressor is shutdown, pressure does not automatically blow down, check for:

1. Normally open regulated air solenoid may be stuck closed.
2. Blockage in air line from downstream of the coalescer to the inlet valve.
3. Inlet valve orifice is clogged.

OIL CONSUMPTION

Abnormal oil consumption or oil in service line, check for the following:

1. Over filling of oil sump.
2. Leaking oil lines or oil cooler.
3. Plugged oil return line: check nozzle beneath the sightglass.
4. Defective coalescer element.
5. Compressor shaft seal leakage.

TROUBLESHOOTING

COALESCER PLUGGING

If the coalescer element has to be replaced frequently because it is plugging up, it is an indication that foreign material may be entering the compressor inlet or the compressor oil is breaking down.

Compressor oil can break down prematurely for a number of reasons.

(1) Extreme operating temperature, (2) negligence in draining condensate from oil sump, (3) using the improper type of oil, (4) dirty oil, (5) oil return nozzle plugged.

The complete air inlet system should be checked for leaks.

HIGH COMPRESSOR DISCHARGE TEMPERATURE

1. Check compressor oil level. Add oil if required (see Section for oil specifications).
2. Check thermal valve operation.
3. Clean outside of oil cooler.
4. Clean oil system (cooler) internally.
5. Check fan relay harness.

COMPRESSOR OPERATION

Before starting the compressor, read this section thoroughly. Familiarize yourself with the controls and indicators, their purpose, location, and use.

CONTROL OR INDICATOR	PURPOSE
TEMPERATURE SWITCHGAUGE	Monitors the temperature of the air/fluid mixture leaving the compressor. The normal reading should be approximately 175 to 210 degrees F. Sends signal to relay when the compressor reaches 240 degrees temperature and the compressor will shut down.
PRESSURE SWITCHGAUGE	Monitors the pressure inside the sump tank. When the pressure reaches 165 PSI the compressor will shut down
HOURMETER	Indicator accumulated hours of actual compressor operation.
FLUID LEVEL SIGHTGLASS	Indicates fluid level in the sump. Proper level should be between midpoint and top of the sightglass. Check this level when the compressor is disengaged and the vehicle is parked on level ground.
PRESSURE RELIEF VALVE	Vents sump pressure to the atmosphere if the pressure inside the sump exceeds 175 PSI.
COMPRESSOR INLET CONTROL VALVE	Regulates the amount of air intake in accordance with the amount of compressed air being used. Isolates fluid in compressor unit on shutdown.
FURNAS SWITCH	Senses air pressure from sump to provide automatic control of the N.O.regulated air solenoid.
N.O. REGULATED AIR SOLENOID	Sends air pressure to intake valve for automatic regulation.
MINIMUM PRESSURE VALVE	Restricts air flow to balance sump and service air pressure. Assures a minimum of 65 PSI to maintain compressor lubrication.

COMPRESSOR OPERATION

OPERATING CONDITIONS

The following conditions should exist for maximum performance of the compressor. The truck should be as close to level as possible when operating. The compressor will operate on a 15 degree sideward and lengthwise tilt without any adverse problems. Operation in ambient temperatures above 100°F (38°C) may experience high temperature shutdown.

NOTE

IF THE COMPRESSOR IS BEING USED TO POWER SANDBLASTING EQUIPMENT, OR AN AIR STORAGE TANK, USE A CHECK VALVE DIRECTLY AFTER THE MINIMUM PRESSURE VALVE TO PREVENT BACKFLOW INTO THE SUMP. THIS CHECK VALVE SHOULD HAVE A MAXIMUM PRESSURE DROP RATING OF 2 PSIG (13.78kPa) OPERATING AND A CAPACITY RATING EQUAL TO THE COMPRESSOR.

NOTE

A COMPRESSOR SERVICE VALVE SHOULD BE LOCATED TO THE HOSE REEL INLET OR THE CUSTOMERS AIR CONNECTION PORT WHEN A HOSE REEL IS NOT USED. TYPICAL PLUMBING FROM THE MACHINE'S AIR OUTLET PORT OCCURS IN THE FOLLOWING ORDER:

- 1. MINIMUM PRESSURE ORIFICE.**
- 2. CHECK VALVE.**
- 3. AIR TANK (WHEN USED).**
- 4. OSHA VALVE.**
- 5. SERVICE VALVE**
- 6. MOISTURE TRAP/GAUGE/OILER COMBINATION (WHEN USED).**
- 7. HOSE REEL (WHEN USED).**

**PARTS AND
ILLUSTRATION
SECTION**

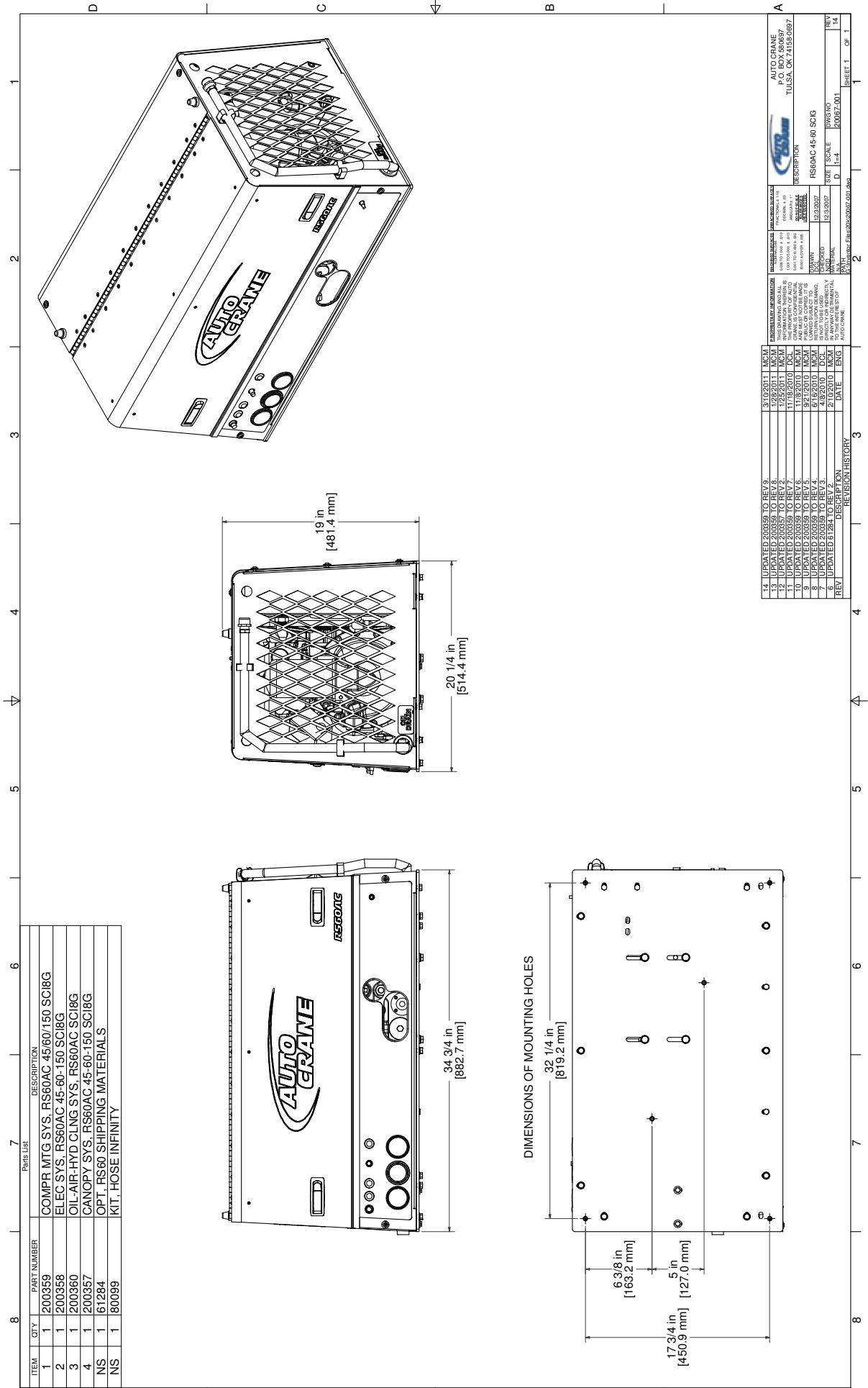

PART LIST		
ITEM	QTY	PART NUMBER
1	1	200359
2	1	200358
3	1	200360
4	1	200357
NS	1	61284
NS	1	80099

DESCRIPTION
COMPR MTG SYS. RS60AC 45/60/150 SCI8G
ELEC SYS. RS60AC 45-60-150 SCI8G
OIL-AIR-HYD CLNG SYS. RS60AC SCI8G
CANOPY SYS. RS60AC 45-60-150 SCI8G
OPT. RS60 SHIPPING MATERIALS
KIT, HOSE INFINITY

NO.	REV	DATE	DESCRIPTION
1	1	05/11/2007	REVISED FOR MANUFACTURING
2	1	12/20/2007	REVISED FOR MANUFACTURING
3	1	05/11/2007	REVISED FOR MANUFACTURING
4	1	12/20/2007	REVISED FOR MANUFACTURING
5	1	05/11/2007	REVISED FOR MANUFACTURING
6	1	12/20/2007	REVISED FOR MANUFACTURING
7	1	05/11/2007	REVISED FOR MANUFACTURING
8	1	12/20/2007	REVISED FOR MANUFACTURING
9	1	05/11/2007	REVISED FOR MANUFACTURING
10	1	12/20/2007	REVISED FOR MANUFACTURING
11	1	05/11/2007	REVISED FOR MANUFACTURING
12	1	12/20/2007	REVISED FOR MANUFACTURING
13	1	05/11/2007	REVISED FOR MANUFACTURING
14	1	12/20/2007	REVISED FOR MANUFACTURING

THIS DRAWING AND ALL INFORMATION CONTAINED HEREIN ARE THE PROPERTY OF MCGRAW-HILL CONSTRUCTION EQUIPMENT DIVISION. ALL RIGHTS ARE RESERVED. NO PART OF THIS DRAWING IS TO BE REPRODUCED OR TRANSMITTED IN ANY FORM OR BY ANY MEANS, ELECTRONIC OR MECHANICAL, INCLUDING PHOTOCOPYING, RECORDING, OR BY ANY INFORMATION STORAGE AND RETRIEVAL SYSTEM, WITHOUT PERMISSION IN WRITING FROM MCGRAW-HILL CONSTRUCTION EQUIPMENT DIVISION. © 2007 MCGRAW-HILL CONSTRUCTION EQUIPMENT DIVISION. ALL RIGHTS RESERVED.

DESCRIPTION: RS60AC 45-60 SCI8G
SCALE: D 1:4
DATE: 12/20/2007
DESIGNER: J. WAGNER
DRWING NO: 20037.001

NO.	REV	DATE	DESCRIPTION
1	1	05/11/2007	REVISED FOR MANUFACTURING
2	1	12/20/2007	REVISED FOR MANUFACTURING
3	1	05/11/2007	REVISED FOR MANUFACTURING
4	1	12/20/2007	REVISED FOR MANUFACTURING
5	1	05/11/2007	REVISED FOR MANUFACTURING
6	1	12/20/2007	REVISED FOR MANUFACTURING
7	1	05/11/2007	REVISED FOR MANUFACTURING
8	1	12/20/2007	REVISED FOR MANUFACTURING
9	1	05/11/2007	REVISED FOR MANUFACTURING
10	1	12/20/2007	REVISED FOR MANUFACTURING
11	1	05/11/2007	REVISED FOR MANUFACTURING
12	1	12/20/2007	REVISED FOR MANUFACTURING
13	1	05/11/2007	REVISED FOR MANUFACTURING
14	1	12/20/2007	REVISED FOR MANUFACTURING

AUTO CRANE
 P O BOX 800897
 TULSA, OK 74158-0897

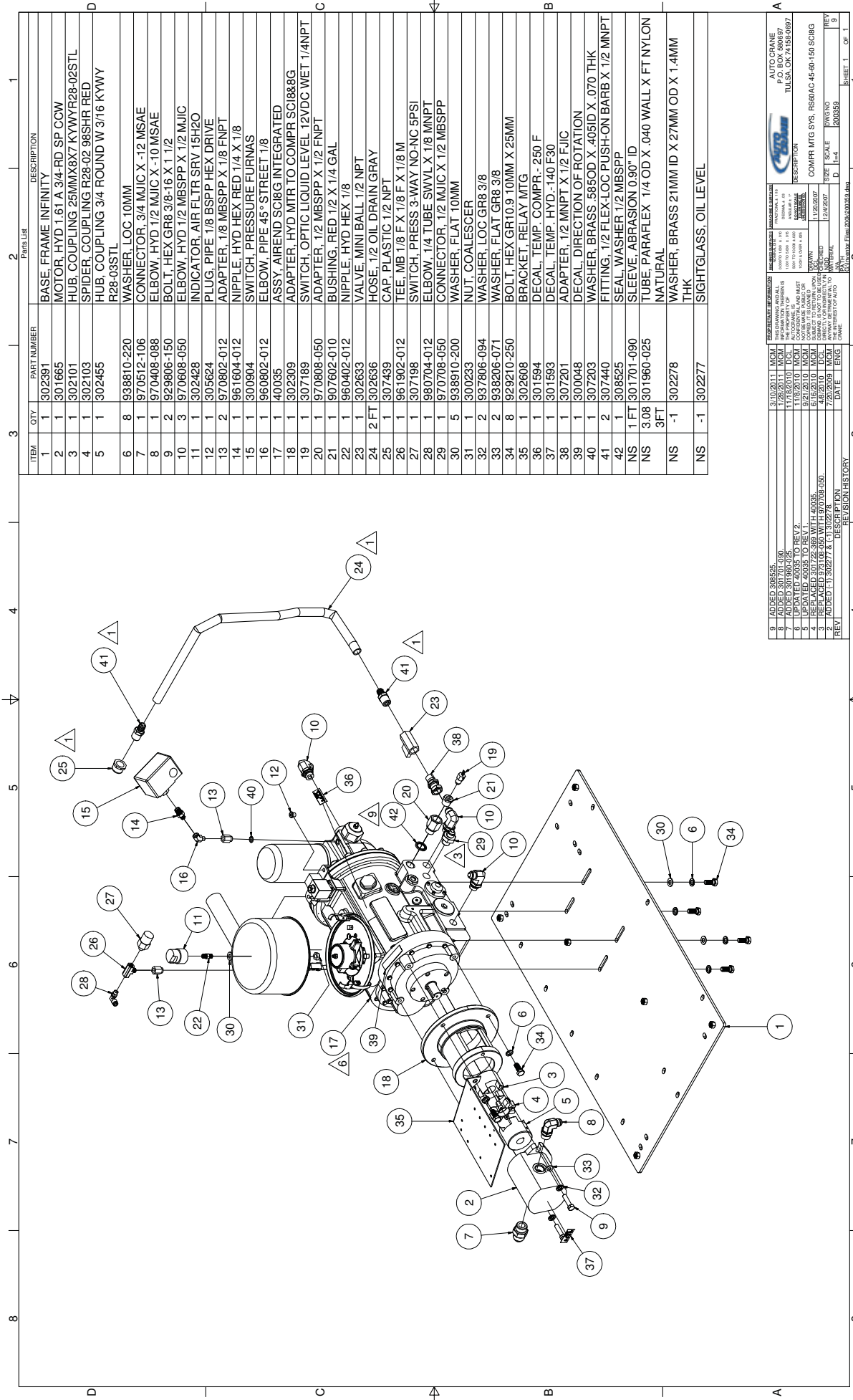

ITEM	QTY	PART NUMBER	DESCRIPTION
1	1	302391	BASE, FRAME INFINITY
2	1	301665	MOTOR, HYD 1.61 A 3/4-RD SP CCW
3	1	302101	HUB, COUPLING 25MMX8X7 KYWYR28-02STL
4	1	302103	SPIDER, COUPLING R28-02 98SHR RED
5	1	302455	HUB, COUPLING 3/4 ROUND W 3/16 KYWY R28-03STL
6	8	938810-220	WASHER, LOC 10MM
7	1	970512-106	CONNECTOR, 3/4 MJIC X -12 MSAE
8	1	970408-088	ELBOW, HYD 1/2 MJIC X -10 MSAE
9	2	929806-150	BOLT, HEX GR8 3/8-16 X 1 1/2
10	3	970608-050	ELBOW, HYD 1/2 MBSPP X 1/2 MJIC
11	1	302428	INDICATOR, AIR FLTR SRV 15H20
12	1	305624	PLUG, PIPE 1/8 BSPP HEX DRIVE
13	2	970802-012	ADAPTER, 1/8 MBSPP X 1/8 FNPT
14	1	961604-012	NIPPLE, HYD HEX RED 1/4 X 1/8
15	1	300904	SWITCH, PRESSURE FURNAS
16	1	960802-012	ELBOW, PIPE 45° STREET 1/8
17	1	40035	ASSY, AIREND SC18G INTEGRATED
18	1	302309	ADAPTER, HYD MTR TO COMPR SC188&G
19	1	307189	SWITCH, OPTIC LIQUID LEVEL 12VDC WET 1/4NPT
20	1	970808-050	ADAPTER, 1/2 MBSPP X 1/2 FNPT
21	1	907602-010	BUSHING, RED 1/2 X 1/4 GAL
22	1	960402-012	NIPPLE, HYD HEX 1/8
23	1	302633	VALVE, MINI BALL 1/2 NPT
24	2 FT	302636	HOSE, 1/2 OIL DRAIN GRAY
25	1	307439	CAP, PLASTIC 1/2 NPT
26	1	961902-012	TEE, MB 1/8 F X 1/8 F X 1/8 M
27	1	307198	SWITCH, PRESS 3-WAY NO-NC 5PSI
28	1	960704-012	ELBOW, 1/4 TUBE SWVL X 1/8 MNPT
29	1	970708-050	CONNECTOR, 1/2 MJIC X 1/2 MBSPP
30	5	938910-200	WASHER, FLAT 10MM
31	1	300233	NUT, COALESCER
32	2	937806-094	WASHER, LOC GR8 3/8
33	2	938206-071	WASHER, FLAT GR8 3/8
34	8	929210-250	BOLT, HEX GR10.9 10MM X 25MM
35	1	302608	BRACKET, RELAY MTG
36	1	301594	DECAL, TEMP. COMPR.-250 F
37	1	301593	DECAL, TEMP. HYD.-140 F30
38	1	307201	ADAPTER, 1/2 MNPT X 1/2 FJIC
39	1	300048	DECAL, DIRECTION OF ROTATION
40	1	307203	WASHER, BRASS .5850D X .4051 X .070 THK
41	2	307440	FITTING, 1/2 FLEX-LOC PUSH-ON BARB X 1/2 MNPT
42	1	308525	SEAL, WASHER 1/2 MBSPP
NS	1 FT	301701-090	SLEEVE, ABRASION 0.90" ID
NS	3.08	301960-025	TUBE, PARAFLEX 1/4 OD X .040 WALL X FT NYLON NATURAL
NS	-1	302278	WASHER, BRASS 21MM ID X 27MM OD X 1.4MM THK
NS	-1	302277	SIGHTGLASS, OIL LEVEL

REV	DATE	BY	REASON	DESCRIPTION
9	11/28/2011	11/28/2011	11/28/2011	11/28/2011
8	11/18/2010	11/18/2010	11/18/2010	11/18/2010
7	11/18/2010	11/18/2010	11/18/2010	11/18/2010
6	11/18/2010	11/18/2010	11/18/2010	11/18/2010
5	11/18/2010	11/18/2010	11/18/2010	11/18/2010
4	11/18/2010	11/18/2010	11/18/2010	11/18/2010
3	11/18/2010	11/18/2010	11/18/2010	11/18/2010
2	11/18/2010	11/18/2010	11/18/2010	11/18/2010
1	11/18/2010	11/18/2010	11/18/2010	11/18/2010

REV	DATE	BY	REASON	DESCRIPTION
9	11/28/2011	11/28/2011	11/28/2011	11/28/2011
8	11/18/2010	11/18/2010	11/18/2010	11/18/2010
7	11/18/2010	11/18/2010	11/18/2010	11/18/2010
6	11/18/2010	11/18/2010	11/18/2010	11/18/2010
5	11/18/2010	11/18/2010	11/18/2010	11/18/2010
4	11/18/2010	11/18/2010	11/18/2010	11/18/2010
3	11/18/2010	11/18/2010	11/18/2010	11/18/2010
2	11/18/2010	11/18/2010	11/18/2010	11/18/2010
1	11/18/2010	11/18/2010	11/18/2010	11/18/2010

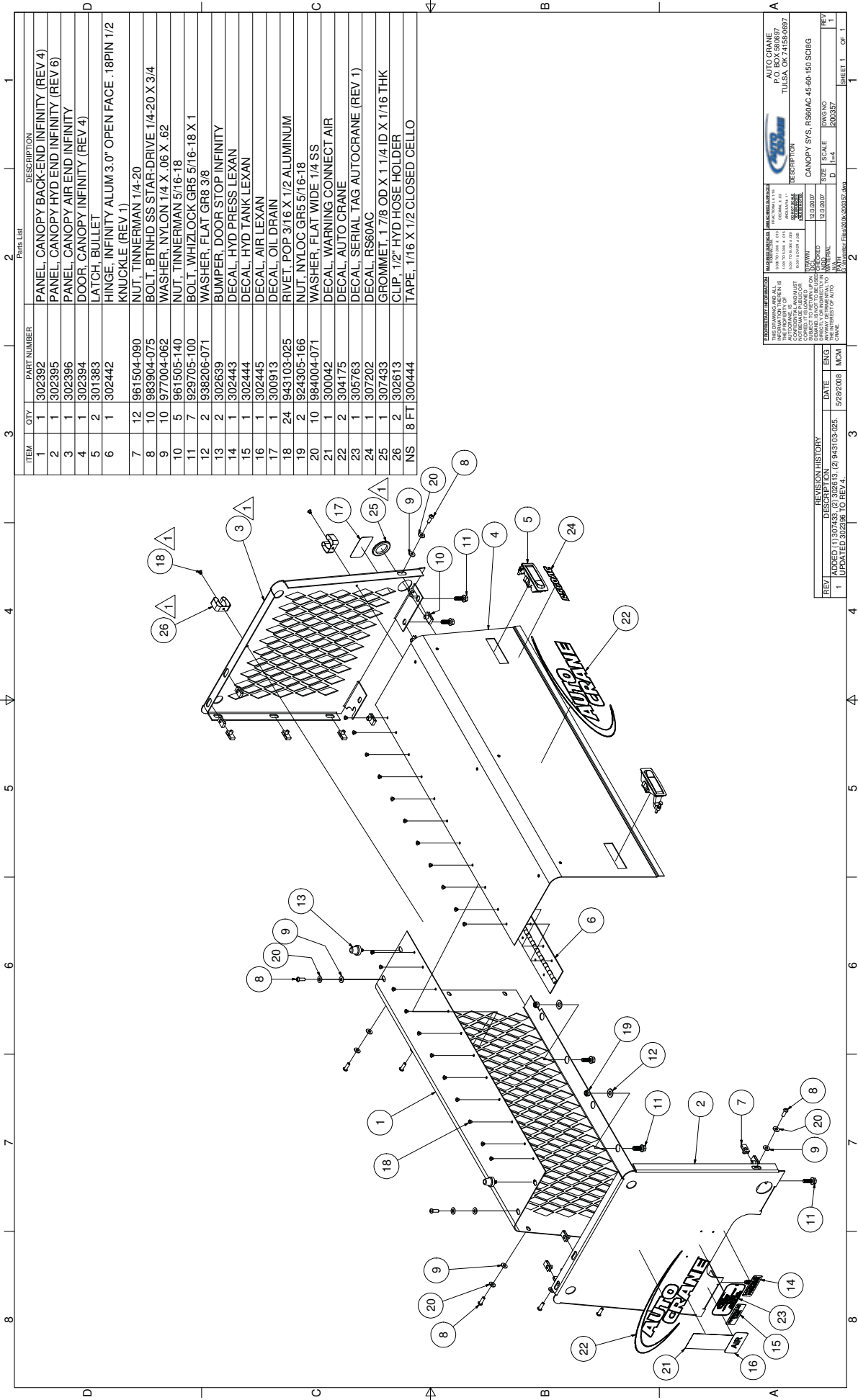

ITEM	QTY	PART NUMBER	DESCRIPTION
1	1	302392	PANEL, CANOPY BACK-END INFINITY (REV 4)
2	1	302395	PANEL, CANOPY HYD-END INFINITY (REV 6)
3	1	302396	PANEL, CANOPY AIR END INFINITY
4	1	302394	DOOR, CANOPY INFINITY (REV 4)
5	2	301383	LATCH, BULLET
6	1	302442	HINGE, INFINITY ALUM 3.0" OPEN FACE .18PIN 1/2
7	12	961504-090	NUT, TINNERMAN 1/4-20
8	10	983904-075	BOLT, BTINHD SS STAR-DRIVE 1/4-20 X 3/4
9	10	977004-062	WASHER, NYLON 1/4 X .06 X .62
10	5	961505-140	NUT, TINNERMAN 5/16-18
11	7	929705-100	BOLT, WHIZLOCK GR5 5/16-18 X 1
12	2	938206-071	WASHER, FLAT GR8 3/8
13	2	302639	BUMPER, DOOR STOP INFINITY
14	1	302443	DECAL, HYD PRESS LEXAN
15	1	302444	DECAL, HYD TANK LEXAN
16	1	302445	DECAL, AIR LEXAN
17	1	300913	DECAL, OIL DRAIN
18	24	943103-025	RIVET, POP 3/16 X 1/2 ALUMINUM
19	2	924305-166	NUT, NYLOC GR5 5/16-18
20	10	984004-071	WASHER, FLAT WIDE 1/4 SS
21	1	300042	DECAL, WARNING CONNECT AIR
22	2	304175	DECAL, AUTO CRANE
23	1	305763	DECAL, SERIAL TAG AUTO CRANE (REV 1)
24	1	307202	DECAL, RS60AC
25	1	307433	GROMMET, 1 7/8 OD X 1 1/4 ID X 1/16 THK
26	2	302613	CLIP, 1/2" HYD HOSE HOLDER
NS	8 FT	300444	TAPE, 1/16 X 1/2 CLOSED CELLO

THIS DRAWING AND ALL INFORMATION CONTAINED HEREIN ARE THE PROPERTY OF AUTO CRANE. IT IS TO BE USED FOR THE MANUFACTURE OF AUTO CRANE EQUIPMENT ONLY. IT IS NOT TO BE REPRODUCED OR TRANSMITTED IN ANY FORM OR BY ANY MEANS, ELECTRONIC OR MECHANICAL, INCLUDING PHOTOCOPYING, RECORDING, OR BY ANY INFORMATION STORAGE AND RETRIEVAL SYSTEM. WITHOUT THE WRITTEN PERMISSION OF AUTO CRANE, INC.

REV	DESCRIPTION	DATE	ENG	INCH
1	ADDED (1) 307433, (2) 302613, (2) 943103-025, 5282008	5/28/2008	MCN	
1	UPDATED 302396 TO REV 4.			

REVISION	DATE	BY	CHKD	APP'D
1	12/03/07			
2	12/03/07			

DESCRIPTION: AUTO CRANE
 P.O. BOX 680897
 TULSA, OK 74155-0897

REV	DATE	BY	CHKD	APP'D
1	12/03/07			
2	12/03/07			

DESCRIPTION: CANOPY SYS. RS60AC-45-60-150 SCIRG
 SIZE: SCALE: 1:1
 D: 1:4
 200357

REV	DATE	BY	CHKD	APP'D
1	12/03/07			
2	12/03/07			

DESCRIPTION: CANOPY SYS. RS60AC-45-60-150 SCIRG
 SIZE: SCALE: 1:1
 D: 1:4
 200357

REV	DATE	BY	CHKD	APP'D
1	12/03/07			
2	12/03/07			

DESCRIPTION: CANOPY SYS. RS60AC-45-60-150 SCIRG
 SIZE: SCALE: 1:1
 D: 1:4
 200357

4		3		2		1	
Parts List		Parts List		Parts List		Parts List	
ITEM	QTY	PART NUMBER	DESCRIPTION	ITEM	QTY	PART NUMBER	DESCRIPTION
1	1	307192	PANEL, GAUGE & LIGHTS INFINITY 08	13	1	901215-005	COUPLING, PIPE 1/8 GAL 150PSI
2	1	300074	GAUGE, HOURMETER	14	1	980604-012	CONNECTOR, TUBE 1/4 PAR X 1/8 NPT
3	1	302449	LIGHT, INDICATING GREEN	15	3	300211	RELAY, POWER
4	2	302450	LIGHT, INDICATING RED	16	1	307196	ENCLOSURE, COMPACT RELAY
5	1	302592	SWITCH, N O MOMENTARY SPST	17	4	931601-050	SCREW, MACH RD HD #8-32 X 1/2
6	1	302486	BREAKER, PANEL MTG RESET	18	4	924301-156	NUT, NYLOC GR5 #8-32
7	3	929705-100	BOLT, WHIZLOCK GR5 5/16-18 X 1	19	1	302678	BRACKET, RELAY HOLDER INFINITY
8	3	961505-140	NUT, TINNEMAN 5/16-18	20	2	929102-050	BOLT, HEX GR5 #6-32 X 1/2
9	1	307191	DECAL, INFINITY 08 GAUGE PANEL	21	1	302780	TIMER, RELAY 12V 30 SEC N.C.
10	1	300076-004	SWITCHGAUGE, TMP 4 ft - 250	22	2	924200-114	NUT, MACH #6-32
11	1	300075	SWITCHGAUGE, PRESSURE	NS	1	307190	RELAY, COMPACT 12VDC 30MA
12	1	302591	SWITCH, SHUTDOWN 117LF WITHOUT FUSE	NS	1	307193	HARNES, WIRING INFINITY 08

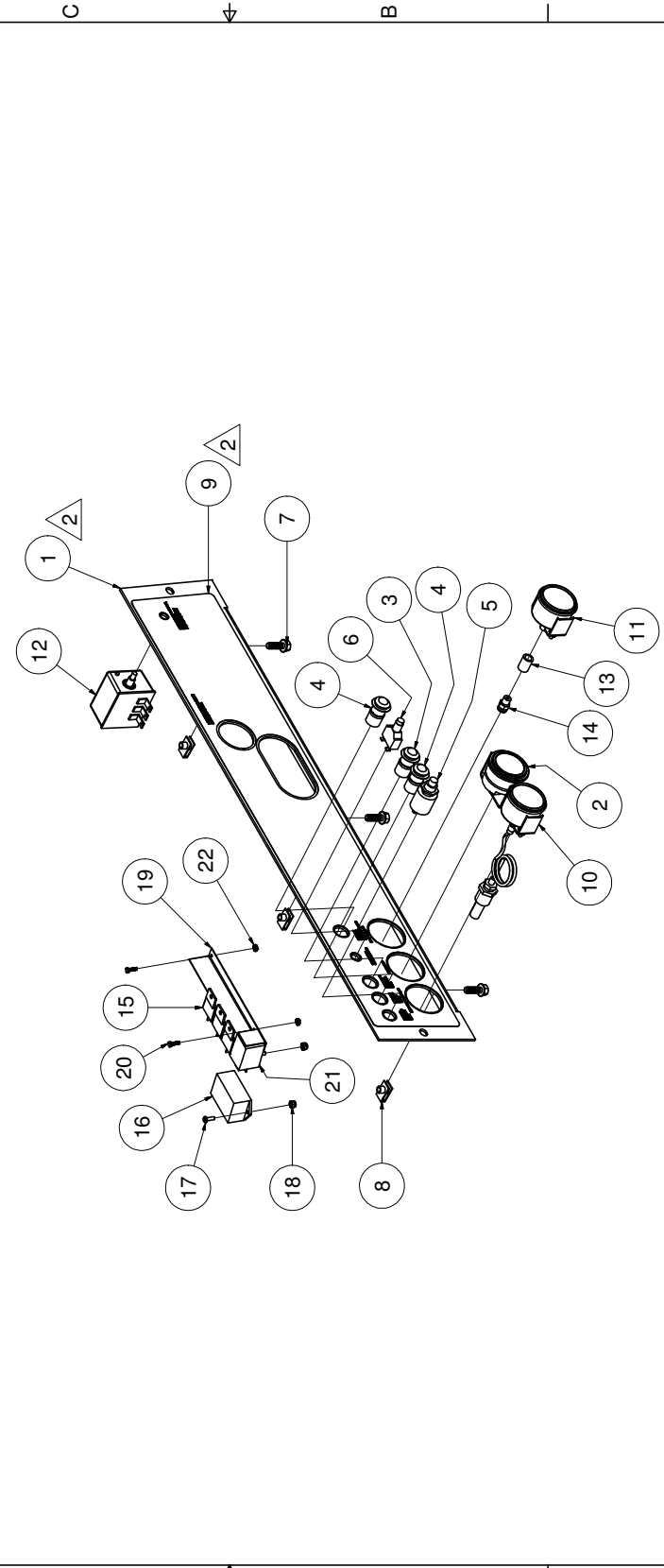

PROPRIETARY INFORMATION THIS DRAWING AND ALL INFORMATION THEREIN IS THE PROPERTY OF INFINITY CRANE. IT IS CONFIDENTIAL AND MUST NOT BE MADE PUBLIC IN ANY MANNER WITHOUT THE WRITTEN CONSENT OF INFINITY CRANE. LOANED SUBJECT TO RETURN UPON DEMAND. IS DIRECTLY OR INDIRECTLY TO THE INTEREST OF AUTO CRANE.		INCHES SUBJECT TO 1/16" TOLERANCE FRACTIONAL & 1/8" ANGULARS 1/16" TOLERANCE 1000 TO 10000 & 0.001 1000'S OVER & 0.02	DRAWN: DCL CHECKED: DCL MATERIAL: 12/4/2007 PATH: C:\inventor\Files\2006\200358.dwg	AUTO CRANE P.O. BOX 586897 TULSA, OK 74158-0897
2 UPDATED 307191 TO REV 1 & 307192 TO REV 1 1 307190 QTY (1) WAS (083)		DATE: 9/14/2009 ENG: MCM DATE: 4/16/2009 ENG: MCM	DESCRIPTION: ELEC SYS, RS60AC 45-60-150 SCIRG SIZE: C 1=4 DWG NO: 200358	REV: 2 SHEET 1 OF 1

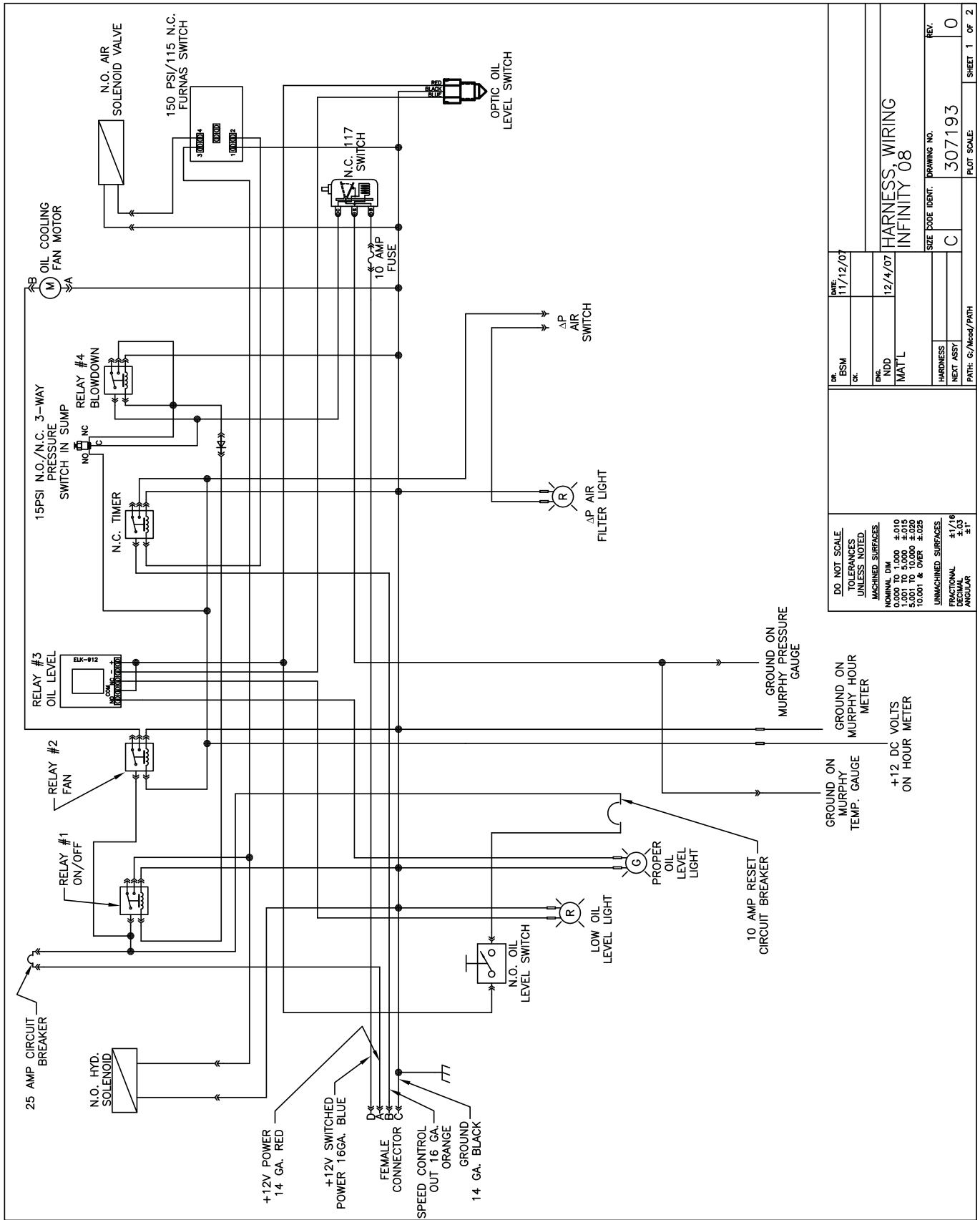

DR.	BSM	DATE:	11/12/07
OC.	OC.		
ENC.	NDD		12/4/07
	MAT'L		
HARDNESS:		SIZE CODE IDENT:	C
NEXT ASST:		DRAWING NO.	307193
PATH: G./Mcd/PATH		REV.	0
		PLOT SCALE:	SHEET 1 OF 2

DO NOT SCALE
TOLERANCES
UNLESS NOTED.

MACHINED SURFACES:
NOMINAL DIM
0.001 TO 0.005 ±0.010
0.005 TO 0.010 ±0.015
0.010 TO 0.030 ±0.020
0.030 TO 0.060 ±0.025
0.060 TO 0.125 ±0.030
0.125 TO 0.250 ±0.040
0.250 TO 0.500 ±0.050
0.500 TO 1.000 ±0.060
1.000 TO 2.000 ±0.080
2.000 TO 5.000 ±0.100
5.000 TO 10.000 ±0.125
10.000 & OVER ±0.150

UNMACHINED SURFACES:
FRACTIONAL
DECIMAL
ANGULAR
±1/16
±.03
±1°

RECOMMENDED SPARE PARTS

PART NUMBER	DESCRIPTION
755500-001	ELEMENT, OIL FILTER SCI8
755500-002	ELEMENT, AIR FILTER SCI 7/8
755500-003	COALESCER, SPIN-ON SCI8
755500-005	KIT, SHAFT SEAL REPAIR SCI8G
755500-007	SPIDER, COUPLING
755500-008	KIT, HYD MOTOR SHAFT SEAL REPAIR
755500-009	VALVE, THERMAL SCI8
755500-010	MOTOR, 1.58 CIR SAE "A" 3/4 RO
755500-011	HUB, COUPLING 25MMX8X7 KYWYR28
755500-012	HUB, COUPLING 3/4 ROUND W 3/16
755500-013	VALVE, INLET SCI 8
755500-046	GASKET, SCI8 AIR FILTER

SERVICE QUESTIONNAIRE

DATE: _____

1. Information given by: _____
2. Information received by: _____
3. Has anyone helped you: Yes _____ No _____
4. Distributor: _____
5. End-User: _____
6. Phone Number: _____
7. Make and Model for PTO: _____
8. AUTO CRANE Serial #: _____
9. Make and Model of Engine: _____
10. Engine: _____
11. Transmission: _____
12. Nature of Problem: _____

13. Engine RPM: _____
14. Compressor RPM: _____
15. Action Taken: _____

Additional Comments: _____

Instructional Procedures for Installation of AUTO CRANE RS60AC Geared Rotary Screw Air Compressor

This air compressor should be installed only by those who have been trained and delegated to do so and who have read and understand both the operators' manual and the installation manual. Failure to follow the instructions, procedures, and safety precautions in this manual may result in accidents and injuries.

Install, use, and operate this air compressor only in full compliance with all pertinent O.S.H.A. requirements and all pertinent Federal, State, and Local codes or requirements and with AUTO CRANE instructions.

Do not modify this compressor except with written factory approval.

WARNING

TO AVOID ANY POTENTIAL OVERHEATING ISSUES, ENSURE CLEARANCE OF ATLEAST 12" AROUND ALL CANOPY OPENINGS.

1. MOUNTING COMPRESSOR

When mounting the compressor care should be taken to ensure that its location does not impede the operation of other components on the vehicle. For example, if your vehicle is equipped with a crane, you must make sure the compressor will not interfere with the swing of the crane. In addition, the compressor should be installed in an area that permits cool ambient air to enter the air filter and the hot air from the cooler to exhaust without recirculating into the air filter. One last consideration in the mounting should be the routing of hoses and electrical wires. The frame mounting holes are shown below and the unit should be secured to the vehicle with 3/8 inch grade 8 bolts, washers should be used on the mounting surface. Hardware supplied with unit, may not work in all applications.

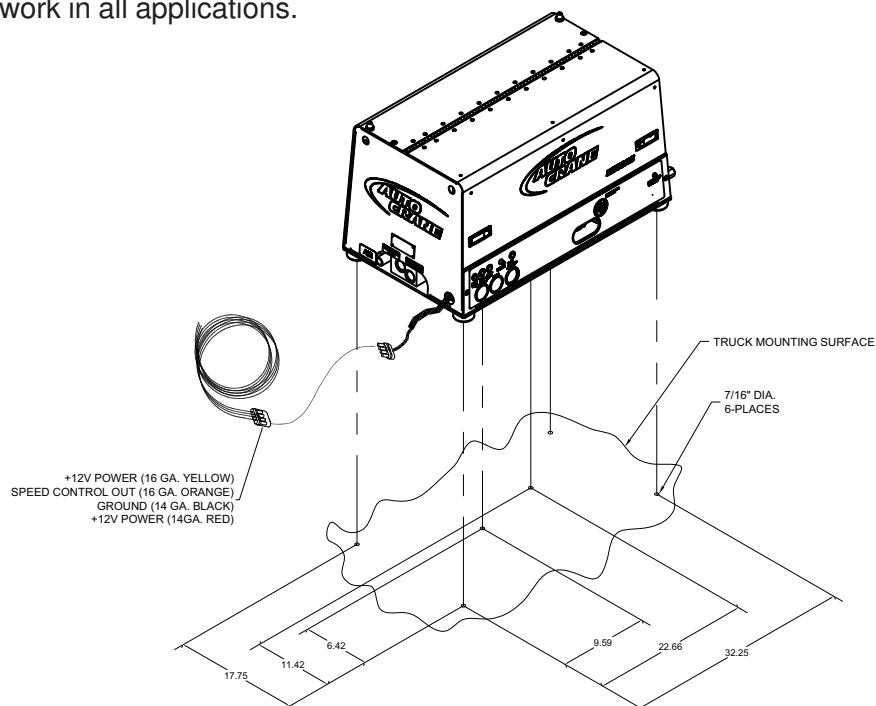

INSTRUCTIONAL PROCEDURES

2. INSTALLING THE WIRING & CONNECTING THE HYDRAULIC HOSES

This unit is shipped from the factory with all necessary internal wiring installed. The only remaining wiring necessary is the wiring needed to interface your vehicle/power source with the AUTO CRANE compressor. (Please refer to drawing 307193 on page 35) The unit is shipped with 4 loose wires, they need to be connected as follows:

1. Connect red wire to switched 12 vdc power. (or 24 VDC if you have this option)
2. The yellow wire should be spliced into the 12 vdc switched feed for the on/off switch per the end-users location.(or 24 VDC if you have this option)
3. Connect black wire to ground.
4. The orange wire is used to activate an electronic speed control circuit if required.
Please contact the factory with engine specific information for further assistance.

CONNECTING THE HOSES

The hydraulic hoses to the compressor should be connected directly to the hydraulic control block. The pressure "P" input line should be made from a good quality high pressure (min. 3000 PSI) hydraulic hose 3/4" i.d. The return line to tank "T" can be made from a medium pressure (min. 1000 PSI) hydraulic hose 1" i.d. Care should be taken to see that the hoses are not installed with kinks or bends that inhibit flow of the hydraulic oil. Lack of flow could result in damage to the motor and compressor. Lastly check to make sure hoses are not in contact with sharp objects or edges that may fray, chafe or cut them over time. Secure all hoses with tie down straps or clamps.

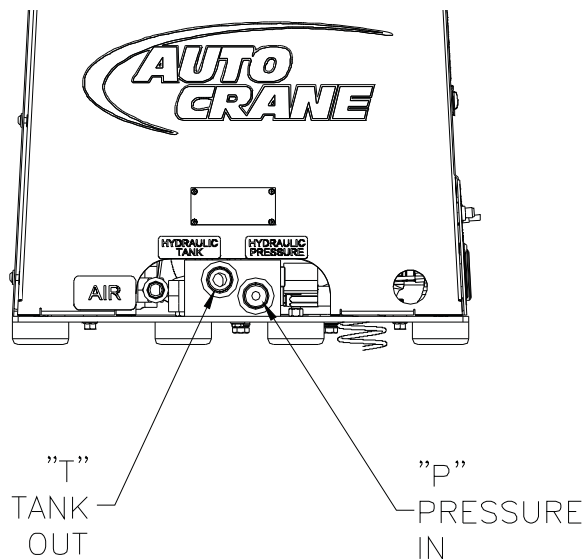

HYDRAULIC RESERVIOR

The RS60AC is designed to operate with a 25 gallon hydraulic reservoir minimum. If additional hydraulic components are utilized, the reservoir should be sized for 25 gallons plus the recommended capacity by the other component manufacturers.

INSTRUCTIONAL PROCEDURES

3. PRE-START-UP INSPECTION CHECKS

This inspection should be done prior to removing truck from bay. Final testing of the system, including checking for leaks, is to be done outside.

ALL TRUCKS SHOULD BE ROAD TESTED PRIOR TO STARTING INSTALLATION TO ISOLATE ANY PREVIOUS TRUCK PROBLEMS.

- I. Check sales order to verify that all compressor related items originally ordered have been installed or are ready to ship with the truck. This would include any special filters, oils, hoses, options, etc.
- II. Vacuum all areas that have metal or plastic shavings. Wipe all fingerprints off unit and vehicle.
- III. Apply decals to proper location. Make sure that the area is cleaned prior to applying decals. All decals should have a professional appearance upon application.
- IV. Check all assemblies, clamps, fittings, drivelines, angles, nuts, and bolts to ensure they are properly tied and secured to the vehicle. This is a very critical area of inspection. The vehicle should not be moved until this inspection has been completed.
- V. Record all serial numbers for this installation.
 - A. Vehicle V.I.N.
 - B. Hydraulic Pump Data
 - C. Air-End Serial Number
 - D. AUTO CRANE Serial Number
 - E. Receiver Tank Serial Number
 - F. Note any special applications relating to specific installations.
- VI. Check all fluid levels (position the unit on a level surface so that proper amount of fluids can be added).
 - A. Fuel to provide for three hours of operation.
 - B. Transmission fluid and PTO box.
 - C. Compressor.
Check the compressor oil sump level (see lubricant section of the operator and parts section for type of lubricant to use). 1. Add oil if needed. 2. Additional oil may need to be added after test. 3. Top off oil level to half the sightglass when finished with the test.
 - D. Any other applicable fluids.

4. INITIAL START-UP AND TEST

- A. Start power source and allow for warm-up.
- B. Read the operation section in the operator and parts manual carefully before proceeding onto the initial start-up.

INSTRUCTIONAL PROCEDURES

C. Engage hydraulic system. A direction of rotation arrow is attached to the compressor package above the hydraulic coupling. The coupling/hub must be rotating in the direction the arrow is pointing. If for any reason this arrow has been removed the correct compressor rotation is clockwise when looking directly at the compressor shaft. Check the direction of rotation by quickly engaging and then disengaging the compressor.

CAUTION

DO NOT RUN THE COMPRESSOR IN A REVERSE ROTATION FOR PERIODS LONGER THAN 5 SECONDS. CONTINUED OPERATION IN THIS MANNER WILL RESULT IN EXTENSIVE COMPRESSOR UNIT DAMAGE.

The safety shutdown switch should be wired in series with the solenoid that opens the flow of the hydraulic oil to the compressor drive motor. In cases of high temperature and/or pressure, the closing of the valve will stop the compressor operation.

Safety circuit testing for RS60AC

Safety circuit testing can be done in the following manner. Start the truck. Engage the compressor. Take a screwdriver and touch the 1/16" allen head screw on the face of the temperature gauge and simultaneously touch the outside ring on the face of the gauge. This should shut off the power to the solenoid of the hydraulics. Push the button in on the shutdown switch to reset. Repeat the test with the pressure gauge if solenoid does not stop flow to compressor, check wiring.

RS60AC WITH AIR RESERVOIR APPLICATION RECOMMENDATION

The RS60AC is designed to provide continuous CFM output and constant pressure without the use of an air reservoir. Air reservoirs are not typically installed on vehicle mounted rotary screw compressors and Auto Crane does not recommend an air reservoir be included as standard equipment for use with the RS60AC compressors

The above notwithstanding, Auto Crane understands that some of our customers want an air reservoir installed on their vehicle in order to facilitate air usage when the vehicle's compressor is not running. Auto Crane also understands that unless properly installed, the air reservoir, plumbing to the reservoir, and subsequent connections and plumbing to the hose reel, along with the hose reel itself, may restrict the flow of usable air delivered to the tool.

The following is a recommendation for using an air reservoir in conjunction with the RS60AC product.

- I. Air Reservoir
 - a. The recommended minimum size of the air reservoir should be 6930 cubic inches (30 gallons). The actual size of the air reservoir can be larger or smaller depending on the duration and demand of air required during the periods of time that the vehicle is not running.
- II. Specifications of the Air Reservoir
 - a. Must meet DOT requirements for air reservoir construction
 - b. Must include a safety relief valve with a maximum relief valve setting of 175psi.
 - c. Must include drain port located at the lowest point to permit the drainage of moisture that normally occurs during the compression of air.
 - d. The drain port should be fitted with a pet cock or other easily operable drain valve to promote regular maintenance of the air system.
- III. Connections and Plumbing
 - a. RS60AC compressor discharge line should be .75" ID and rated for 250F, 300psi minimum.
 - b. Fittings should be .75" ID to minimize air system restrictions.
 - c. Hose reel should be .75" ID to minimize air system restrictions.
 - d. Line droops or condensate traps plumbed into the system should be avoided.

IV. Air System Plumbing

The air reservoir plumbing should be designed to maximize the capabilities of the RS60AC product and air delivery from the hose reel for the operation high volume air consuming tools. The following schematic is recommended.

RS60AC WITH AIR RESERVOIR APPLICATION RECOMMENDATION

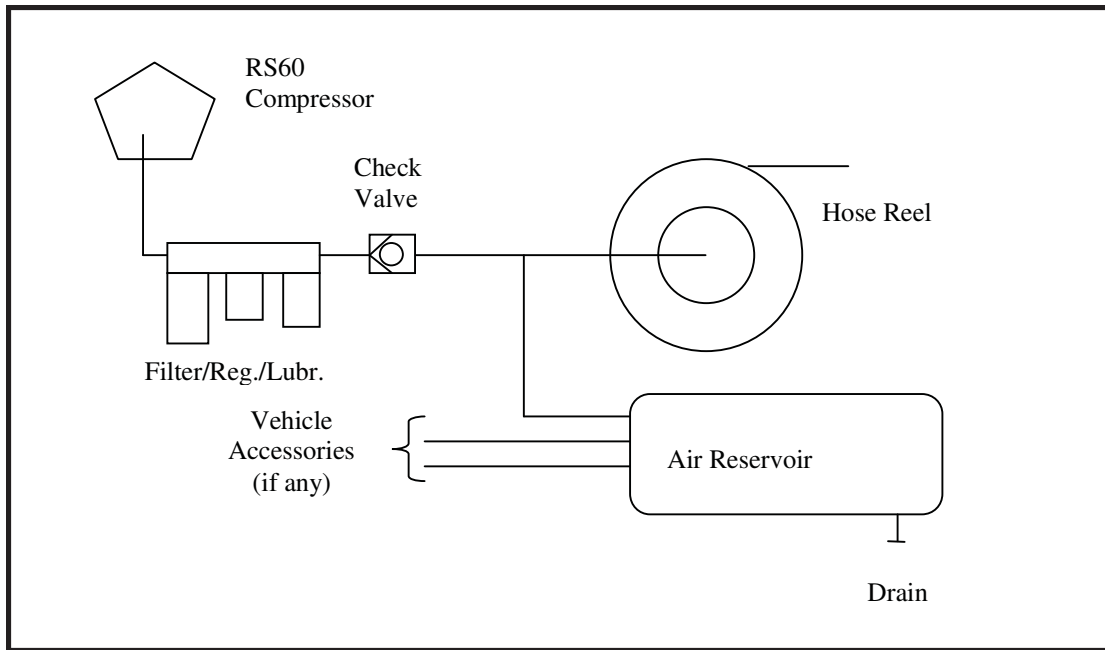

RS60AC with Air Reservoir Schematic Recommendation