

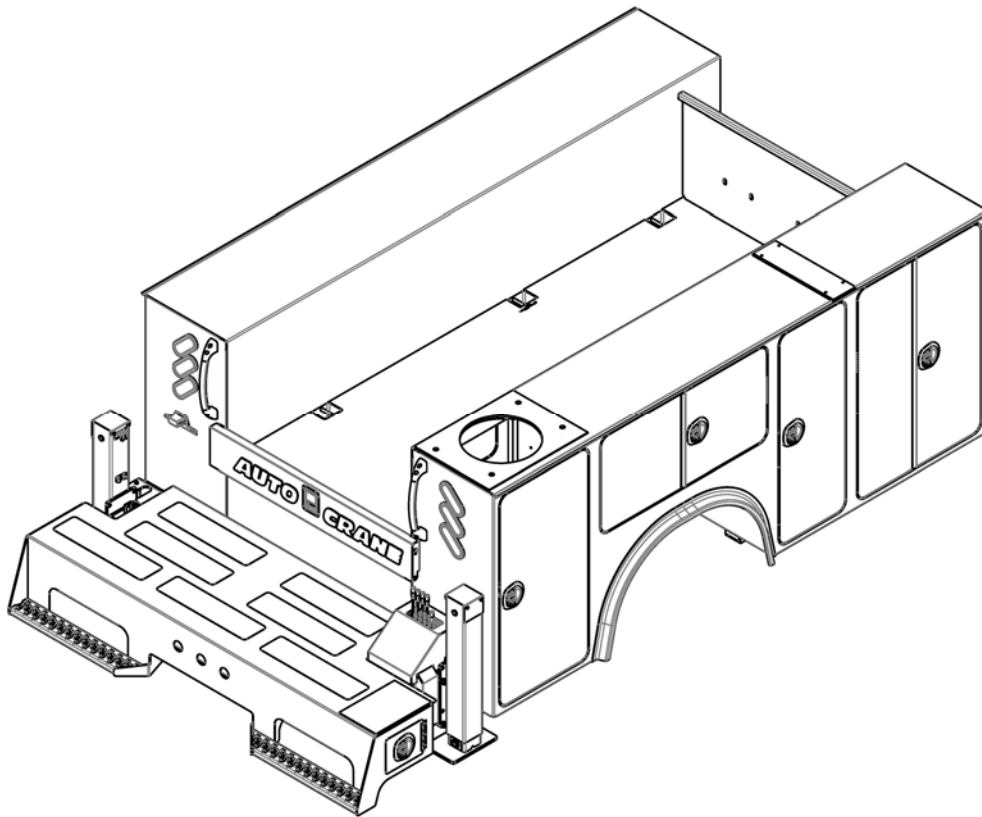

# **TITAN™ 60**

# **OWNERS MANUAL**



**Serial No.** \_\_\_\_\_

**Mailing Address:**  
P.O. Box 580697  
Tulsa, OK 74158-0697  
**Physical Address:**  
4707 N. Mingo Rd.  
Tulsa, OK 74117-5904

**Phone 1-800-777-2760**  
**Fax 1-888-848-5445**  
<http://www.autocrane.com>





# Auto Crane Warranty Registration

Fax Transmission

To: Warranty Department Fax: 1-888-848-5445  
 From: \_\_\_\_\_ Date: \_\_\_\_\_  
 Re: Product Registration Pages: \_\_\_\_\_

**End User Information:** (Required for Warranty Activation)

Name: \_\_\_\_\_ Phone: \_\_\_\_\_  
 Address: \_\_\_\_\_  
 City: \_\_\_\_\_ State: \_\_\_\_\_ Zip: \_\_\_\_\_  
 Contact: \_\_\_\_\_ E-mail Address: \_\_\_\_\_

**Distributor Information:** (Required for Warranty Activation)

Name: \_\_\_\_\_  
 Address: \_\_\_\_\_  
 City: \_\_\_\_\_ State: \_\_\_\_\_ Zip: \_\_\_\_\_  
 Contact: \_\_\_\_\_ E-mail Address: \_\_\_\_\_

**Product Information:** (Required for Warranty Activation)

Model No.: \_\_\_\_\_ Serial No.: \_\_\_\_\_  
 Date Product Delivered: \_\_\_\_\_ Date Processed: \* \_\_\_\_\_  
 VIN # \_\_\_\_\_ \* For Auto Crane use only

## ONE REGISTRATION FORM PER UNIT (CRANE OR BODY)

Registration form must be mailed or faxed within 15 days of customer installation.

Mail to:  
 Warranty Department  
 Auto Crane Company  
 P.O. Box 581510  
 Tulsa, OK 74158-0697



# TITAN 60 OWNER'S MANUAL REVISION RECORD

Revision Date	Section(s) Or Page(s)	Description of Change
5/19/2011	All	New Manual

**Notes:**

1. The information contained in this manual is in effect at the time of this printing. It does not cover all instructions, configurations, accessories, etc. If you require additional information, please contact **Auto Crane Company**.
2. **Auto Crane Company** reserves the right to update this material without notice or obligation.

# ***NOTES***

# WARNINGS

**WARNING!** Federal law (49 CFR 571) requires that the Final Stage Manufacturer of a vehicle certify that the vehicle complies with all applicable federal regulations. Any modifications performed on the vehicle prior to the final state are also considered intermediate stage manufacturing and must be certified as to compliance. The installer of this crane and body is considered one of the manufacturers of the vehicle. As such a manufacturer, the installer is responsible for compliance with all applicable federal and state regulations, and is required to certify that the vehicle is in compliance.

**WARNING!** It is the further responsibility of the installer to comply with the OSHA Truck Crane Stability Requirements as specified by 29 CFR 1910.180 (C) (1).

**WARNING! NEVER OPERATE THE CRANE NEAR ELECTRICAL POWER LINES!**

**Death** or serious injury will result from boom, line, or load contacting electric lines. Do not use crane within 10 feet (3.05m) of electric power lines carrying up to 50,000 volts. One-foot additional clearance is required for every additional 30,000 volts or less. **SEE DANGER DECAL (P/N 040529)** in this Owner's Manual.

**WARNING!** Failure to correctly plumb and wire crane can cause inadvertent operation and damage to crane and/or personnel!

**WARNING!** Vehicle must meet Federal law (49 CFR 393) which states the required parts and accessories necessary for safe operation. This includes lighting, reflectors, etc...

**WARNING!** Federal law (49 CFR 568) requires each final-stage manufacturer to complete the vehicle in such a manner that it conforms to the standards in effect on the date of manufacture of the incomplete vehicle, the date of final completion, or a date between those two dates. This requirement shall, however, be superseded by any conflicting provisions of a standard that applies by its terms to vehicles manufactured in two or more stage. Each final-stage manufacturer shall affix a label to the completed vehicle in accordance with 49 CFR 567.5.

**READ THIS PAGE**





# **TABLE OF CONTENTS**

## **TITAN 60 BODY**

TITAN BODY INTRODUCTION	1-1.0
GENERAL DIMENSIONS	1-2.0
MOUNTING AND INSTALLATION	2-1.0
VEHICLE OPERATION AND PREPARATIONS	3-1.0
TITAN 60 DOOR	4-1.0
TITAN 60 TAILGATE	4-2.0
OUTRIGGER, FULLY MANUAL, DIMENSIONAL	5-1.0
OUTRIGGER, FULLY HYDRAULIC, RIGHT SIDE DIMENSIONAL	5-2.0
OUTRIGGER, FULLY HYDRAULIC, LEFT SIDE DIMENSIONAL	5-3.0
OUTRIGGER SHIP KIT	5-4.0
OUTRIGGER INSTALLATION	5-5.0
OUTRIGGER ASSY, FULLY MANUAL	5-7.0
OUTRIGGER ASSY, FULLY HYDRAULIC	5-9.0
OUTRIGGER HYDRAULIC LEG ASSEMBLY	5-15.0
BUMPER ASSEMBLY 30" MANUAL	6-1.0
BUMPER ASSEMBLY 30" HYDRAULIC	6-3.0
RECEIVER HITCH INSTALLATION	6-5.0
MASTER LOCK SYSTEM	7-1.0
SHELF LOCATION	8-1.0
SLIDE OUT TRAY	8-5.0
TOOL BOX	8-7.0
OXY/ACET ASSY	9-1.0
OXY DIVIDER/SHELVING PACKAGE	9-2.0
DROP WELL	9-3.0
PARTS WASHER	9-4.0
ROPE LIGHT KIT	10-1.0
COMPARTMENT LIGHT KIT	10-5.0
FLOOD LIGHT KIT	11-1.0
BOOM SUPPORT	12-1.0
BULKHEAD RESERVOIR	13-1.0
AIR RECEIVER TANK 30 GALLON	13-2.0
FIRE EXTINGUISHER	14-1.0
BACK UP ALARM	15-1.0
BODY PREVENTIVE MAINTENANCE	16-1.0

# TITAN BODY INTRODUCTION

Auto Crane products are designed to provide many years of safe, trouble-free, dependable service when properly used and maintained.

To assist you in obtaining the best service from your crane and to avoid untimely crane and/or vehicle failure, this manual provides the following operating and service instructions. It is specifically recommended that all operating and service personnel consider this manual as mandatory material for reading and study before operating or servicing Auto Crane products. It is highly recommended that crane owners, equipment managers, and supervisors also read this manual.

For your convenience the overall dimensions of the Titan are included on the General Dimension Drawing. Center of gravity and door openings are also shown.

Remember, the body adds weight to the vehicle. Adding weight may change the driving and riding characteristics of the vehicle unless the appropriate overload spring(s) are installed on the truck. The payload of the vehicle is reduced by the weight of the body. The operator should exercise care when loading the vehicle. Distributing the payload on the vehicle evenly will greatly improve the driving and riding characteristics of the vehicle.

**Auto Crane Company issues a limited warranty certificate with each unit sold. See last page for warranty.**

It has always been Auto Crane Company policy to handle all warranty claims we receive as promptly as possible. If a warranty claim involves discrepant material or workmanship, Auto Crane will take immediate corrective action. It is understandable that Auto Crane Company cannot assume responsibility of liability when it is obvious that our products have been abused, misused, overloaded or otherwise damaged by inexperienced persons trying to operate the equipment without reading the manual.

**Auto Crane will not assume responsibility or liability for any modifications or changes made to unit, or installation of component parts without authorization.**

Auto Crane maintains a strong distributor network and a knowledgeable Customer Service Department. In most cases, an equipment problem is solved via phone conversation with our customer service department. The customer service department also has the ability to bring a local distributor, a regional sales manager, or a factory serviceman into the solution of an equipment problem.

If, through no fault of Auto Crane Company, it is necessary to send an experienced factory serviceman on a field service call the rates stated in the Auto Crane Distributor's Flat Rate Manual will apply.

Auto Crane Company's extensive Research and Development Program allow our customers to use the best equipment on the market. Our Engineering Staff and our knowledgeable sales people are always available to our customers in solving crane and winch-type application problems. When in doubt, call the Auto Crane factory.

**Note: This manual should remain with the body at all times.**

## **DISTRIBUTOR ASSISTANCE:**

Should you require any assistance not given in this manual, we recommend that you consult your nearest Auto Crane Distributor. Our distributors sell authorized parts and have service departments that can solve almost any needed repair. This manual does not cover all maintenance, operating, or repair instructions pertinent to all possible situations. **If you require additional information, please contact the Auto Crane Company.**

The information contained in the manual is in effect at the time of this printing. Auto Crane Company reserves the right to update this material without notice or obligation.

# TITAN 60 / 84CA GENERAL DIMENSIONS

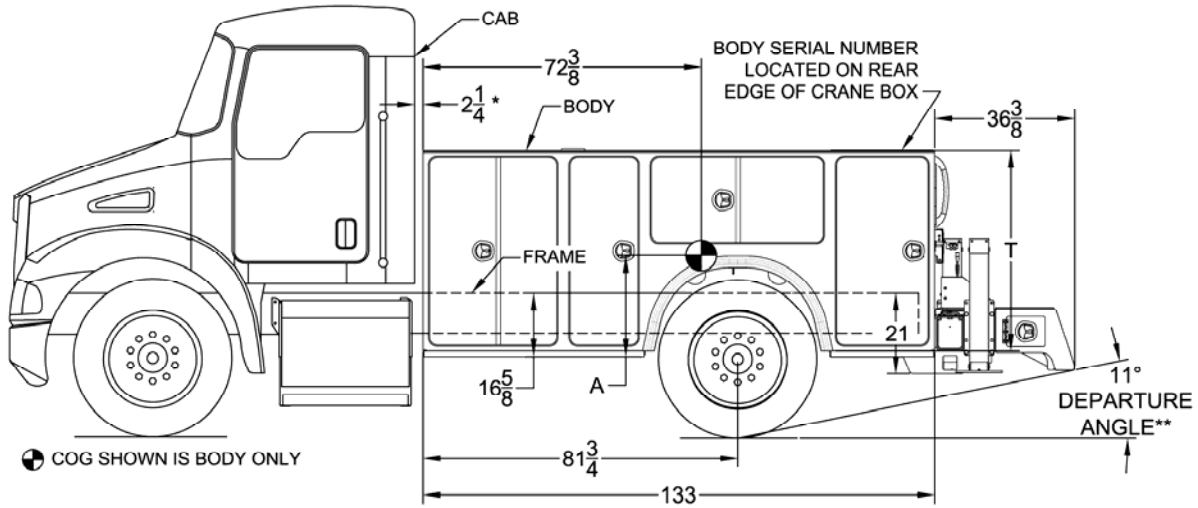

\* STANDARD GAP USING 84CA BODY. CHECK CHASSIS BODY BUILDER BOOK FOR REQUIRED GAP BETWEEN BODY & CHASSIS  
 \*\*DEPARTURE ANGLE SHOWN FOR REFERENCE ONLY. ANGLE WILL VARY DEPENDING ON CHASSIS.

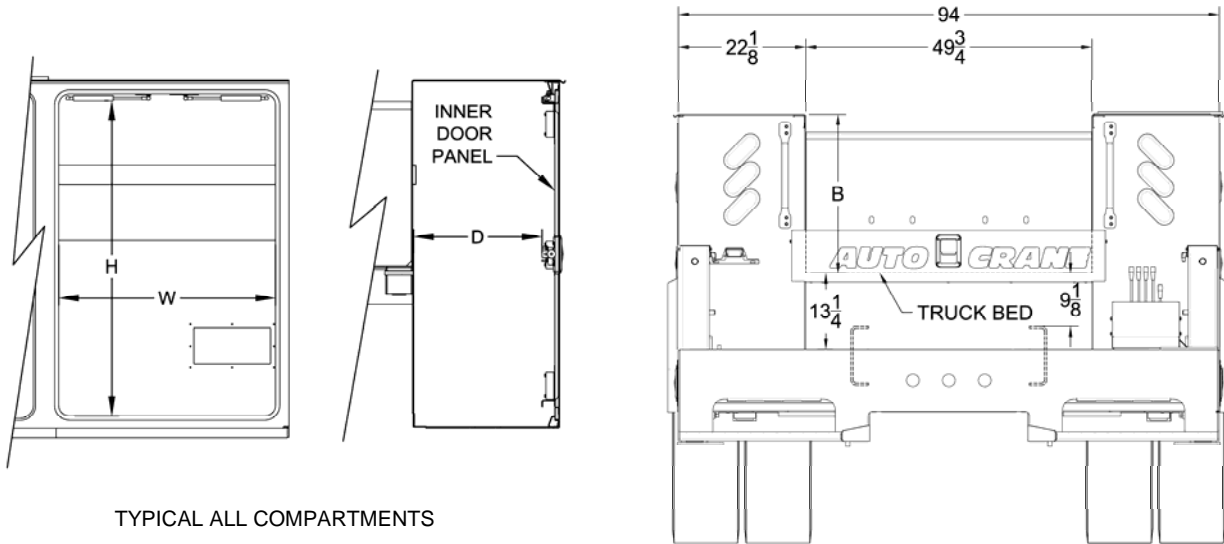

TYPICAL ALL COMPARTMENTS

	84CA / 52" TALL				84CA / 58" TALL				
	B	T	A	WEIGHT	B	T	A	WEIGHT	
GENERAL INFO	27 7/8	52 1/8	27 1/4	3330 LBS.	34	58 1/8	29 1/2	3545 LBS.	
DOOR OPENING SIZES/DEPTH	WIDTH (W)	HEIGHT (H)	DEPTH (D)	VOLUME (FT <sup>3</sup> ) <sup>^</sup>	WIDTH (W)	HEIGHT (H)	DEPTH (D)	VOLUME (FT <sup>3</sup> ) <sup>^</sup>	
FRONT	32 1/2	47 3/8	19 1/8	23.14	32 1/2	53 3/8	19 1/8	25.85	
MID	17	47 3/8	19 1/8	13.52	17	53 3/8	19 1/8	15.10	
HORIZONTAL	44	20 1/2	19 1/8	14.70	44	26 1/2	19 1/8	18.26	
REAR***	23 1/8	47 3/8	19 1/8	17.28	23 1/8	53 3/8	19 1/8	19.30	
TOTAL BODY VOLUME				134.39	TOTAL BODY VOLUME				153.78

\*\*\* REAR COMPARTMENT DIMENSIONS/VOLUME ARE FOR NON CRANE BOX ONLY  
 ^ VOLUME IS TAKEN FROM WALL TO WALL DIMENSIONS **NOT DOOR OPENING SIZES**

# TITAN 60—120CA GENERAL DIMENSIONS

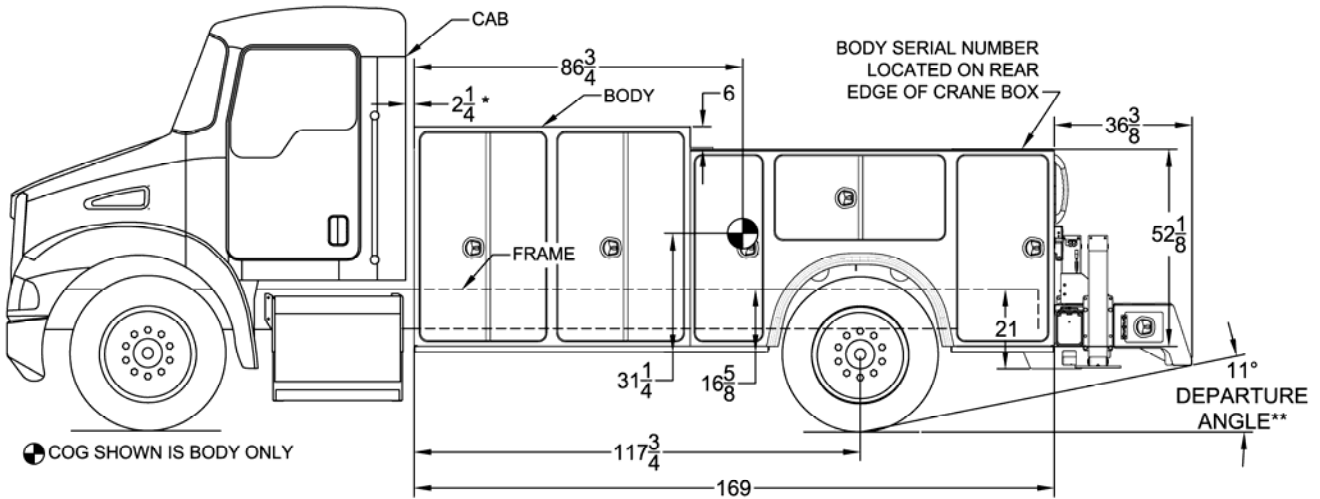

\* STANDARD GAP USING 84CA BODY. CHECK CHASSIS BODY BUILDER BOOK FOR REQUIRED GAP BETWEEN BODY & CHASSIS  
 \*\*DEPARTURE ANGLE SHOWN FOR REFERENCE ONLY. ANGLE WILL VARY DEPENDING ON CHASSIS.

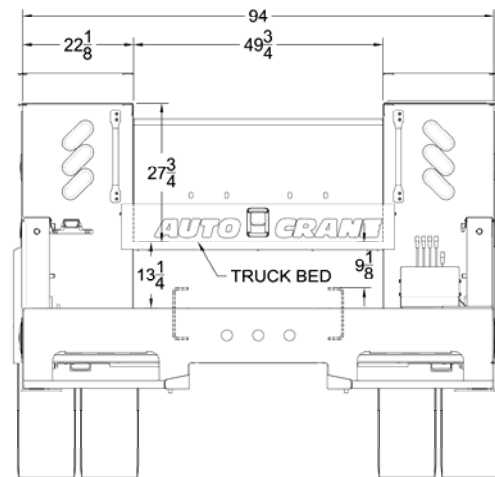
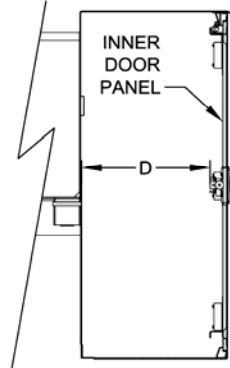
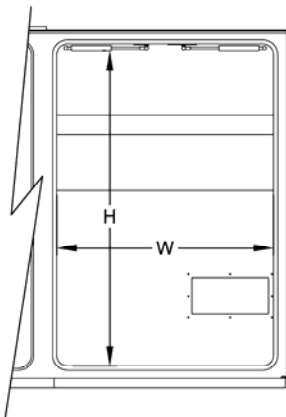

TYPICAL ALL COMPARTMENTS

	120CA			
	WEIGHT		4134 LBS.	
DOOR OPENING SIZES/DEPTH	WIDTH (W)	HEIGHT (H)	DEPTH (D)	VOLUME (FT <sup>3</sup> ) <sup>^</sup>
FRONT (1)	32 3/8	53 1/4	19 1/8	25.85
FRONT (2)	32 3/8	53 1/4	19 1/8	25.98
MID	16 3/8	47 1/4	19 1/8	13.15
HORIZONTAL	44	20 1/2	19 1/8	14.70
REAR***	23 1/8	47 1/4	19 1/8	17.28
TOTAL BODY VOLUME				191.03

\*\*\* REAR COMPARTMENT DIMENSIONS/VOLUME ARE FOR NON CRANE BOX ONLY  
 ^ VOLUME IS TAKEN FROM WALL TO WALL DIMENSIONS **NOT DOOR OPENING SIZES**

# ***NOTES***

# TITAN 60 MOUNTING AND INSTALLATION

Check to make sure the following items are with your Titan body. If components are missing, contact AutoCrane Customer Service Department.

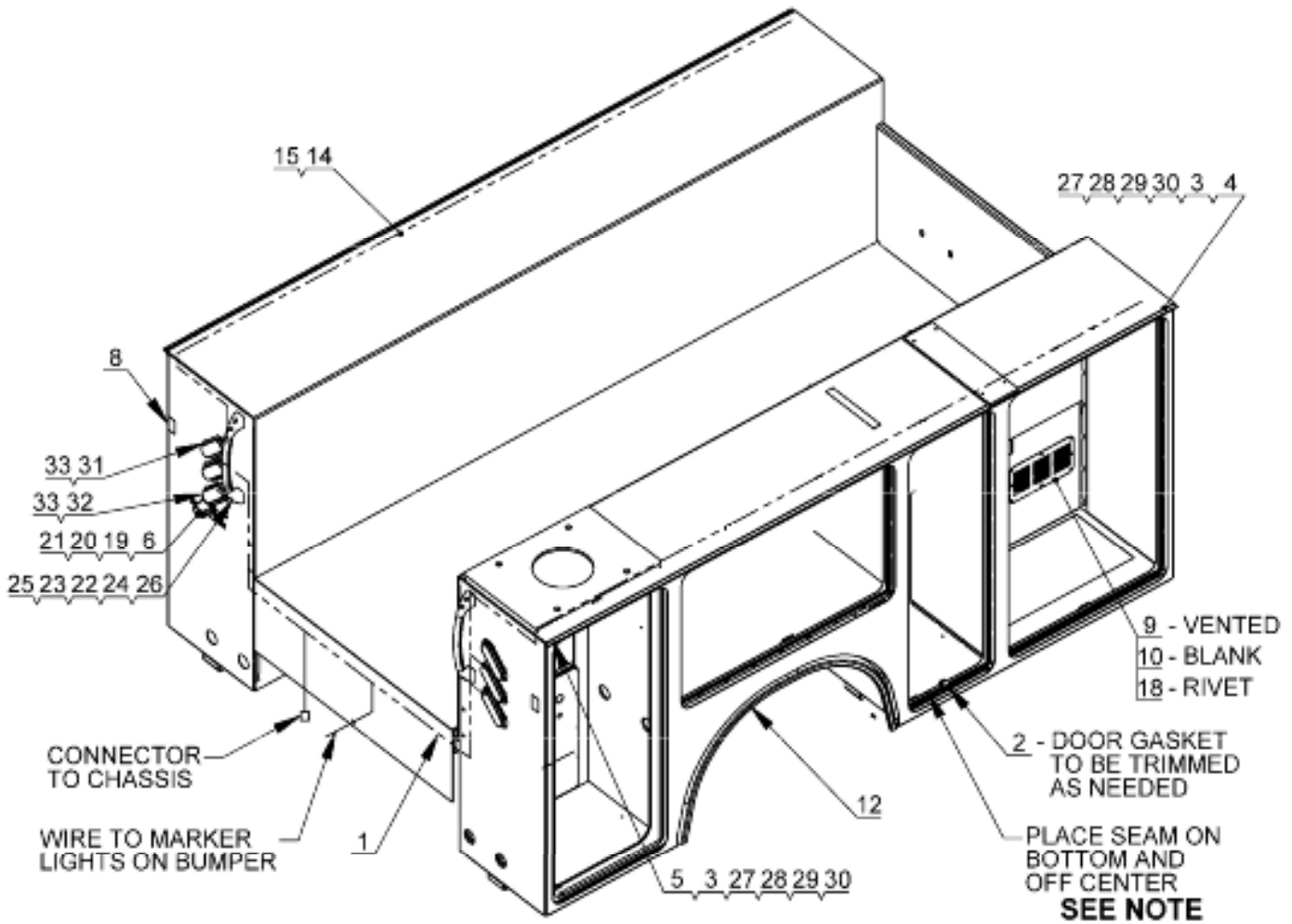

NOTE: APPLY ATV SEALANT TO ONE END OF DOOR GASKET. PRESS BOTH ENDS TOGETHER AFTER INSTALLING. SMEAR ANY EXCESS SEALANT AROUND THE SEAM WHEN COMPLETE.

ITEMS LISTED ON THE FOLLOWING PAGE ARE INCLUDED IN THE BODY SHIP KIT.

P/N 760710105—TITAN 60/84 CA SHIPKIT  
P/N 760720000—TITAN 60/120CA SHIPKIT

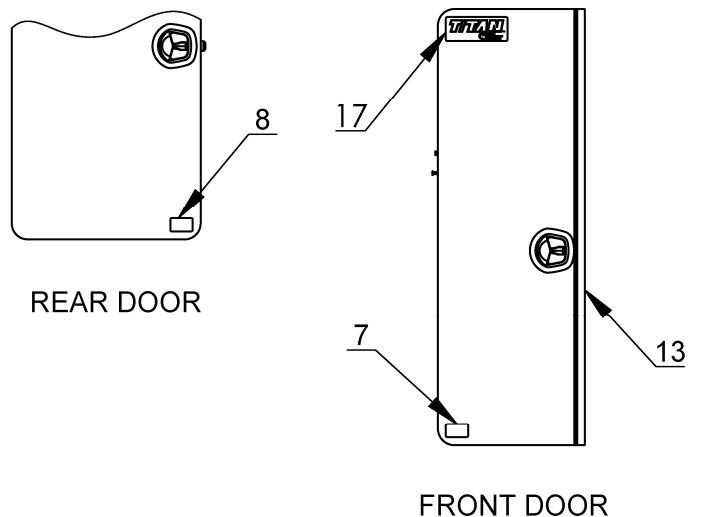

# **TITAN 60**

## **MOUNTING AND INSTALLATION**

<b>ITEM NO.</b>	<b>84 CA</b>	<b>120 CA</b>	<b>PART NUMBER</b>	<b>DESCRIPTION</b>
1	1	1	560106003	HARNES, BODY WIRING W/ACCESSORY OPTION
2	1	2	560114000	DOOR GASKET
3	4	4	560449000	MOUNTING BRACKET
4	2	2	560450000	CLEARANCE MARKER (AMBER)
5	2	2	560451000	CLEARANCE MARKER (RED)
6	1	1	750980000	LAMP, LICENSE W/BRACKET
7	2	2	560452000	REFLECTOR (AMBER)
8	4	4	560453000	REFLECTOR (RED)
9	1	1	752221000	PANEL LOUVER
10	2	2	752222000	PANEL BLANK
11	2	2	750732000	ROCK GUARD
12	1	1	752912000	FENDERETTE INSTALLATION KIT
13	168"	260"	750740000	FLAT GASKET 1" X 1/8 THICK
14	12	12	750737000	TIE-WRAP (PUSH IN)
15	12	12	750738000	STICK-ON, CABLE TIE MOUNT
16	32	32	750736000	CONVOLUTED LOOM 7/16" DIA
17	2	2	560510000	"TITAN" DECAL
18	20	20	754028000	POP RIVET 3/16 DIA X 1/4-3/8 GRIP SS
19	2	2	002609000	SCREW, ROUND HEAD #10-32UNF X 5/8LG
20	2	2	019900000	FLAT WASHER #10
21	2	2	015800000	HEX NUT NYLOCK #10-32UNF GR3 ZINC-PLATED
22	2	2	760629000	GRAB HANDLE BLACK PLASTIC W/GRIP
23	4	4	739408008	SCREW, FLAT 1/4-20UNC 1-3/8LG SOCKET HEAD
24	4	4	739408007	SCREW, FLAT 1/4-20UNC 1-3/4LG SOCKET HEAD
25	8	8	020200000	LOCK WASHER 1/4
26	8	8	015900000	HEX NUT 1/4-20UNC SS
27	5	5	560540000	NYLON GROMMET
28	8	8	000602000	SCREW PAN HEAD #6-32UNC X 1"LG
29	8	8	019600000	LOCK WASHER #6
30	8	8	015400000	HEX NUT, #6-32 UNC
31	4	4	739408003	STOP/TAIL/TURN OVAL LIGHT
32	2	2	759056010	BACK-UP OVAL LIGHT
33	6	6	739408005	OVAL LIGHT GROMMET

# TITAN 60 MOUNTING AND INSTALLATION

## !! WARNINGS !!

DO NOT WELD TO TRUCK FRAME. REFER TO BODY-BUILDERS MANUAL FOR FUTURE INFORMATION

INSTALLATION INSTRUCTIONS BELOW ARE COMMON MOUNTING PRACTICES, ALWAYS REFER TO CHASSIS BODY-BUILDERS MANUAL FOR ACCEPTABLE MOUNTING OPTIONS

CUTTING AFTER-FRAME MAY BE REQUIRED. REFER TO CHASSIS BODY-BUILDERS MANUAL FOR PROPER CUTTING PROCEDURE.

### MINIMUM CHASSIS REQUIREMENTS

- 26,000 LBS GVWR
- 34" FRAME WIDTH
- HEAVY-DUTY REINFORCED FRAME

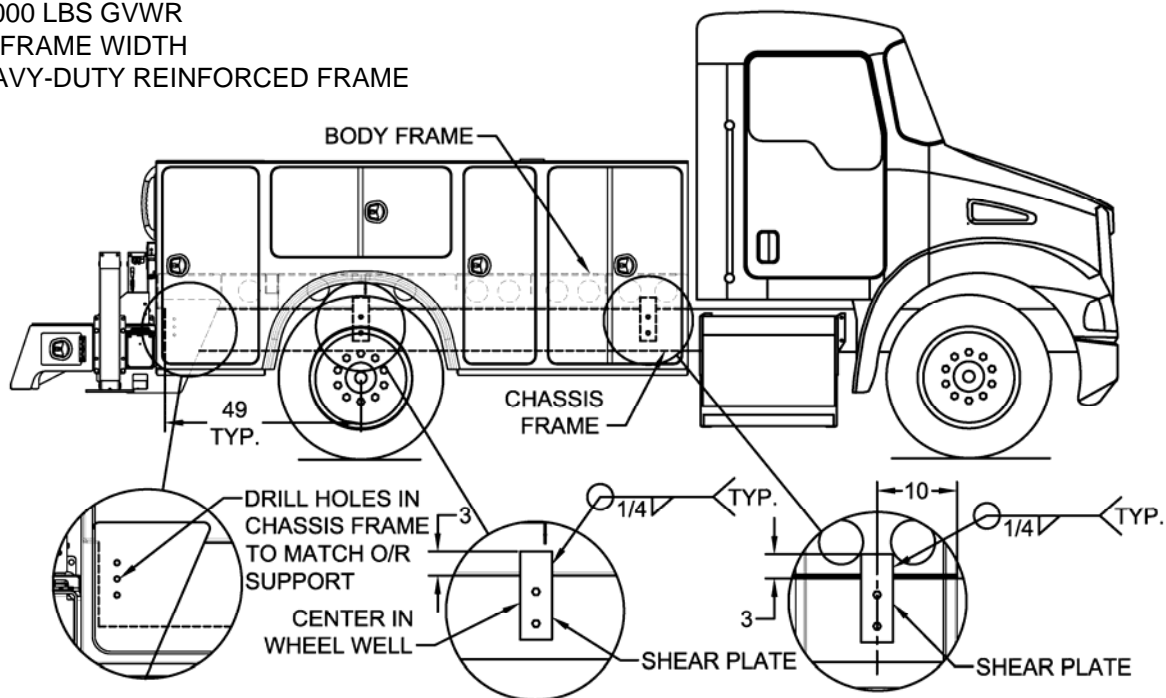

ALL DIMENSIONS SHOWN ARE IN INCHES.

### MOUNTING INSTRUCTIONS:

AVAILABLE MOUNTING KIT—560581000 INCLUDES HARDWARE & SHEAR PLATES

1. Pick up body using a 4-point choke chain rated for the body weight shown in Gen. Dimension page. Use the tie down locations in bed for lifting points.
2. Center body along the width of the chassis and center the wheel well with the tires.  
**NOTE: MAKE SURE YOU HAVE ENOUGH CLEARANCE BETWEEN BODY AND CHASSIS CAB PER THE MANUFACTURERS REQUIREMENTS.**
3. Locate the shear plates as shown in the above diagram. Drill (2)  $21/32\text{\O}$  holes into each shear plate and chassis frame.

**NOTE: LOCATE HOLE FOR BOLT SO THAT THE BOLT, WASHER, AND NUT WILL NOT INTERFERE WITH ANY CHASSIS COMPONENTS. LOCATIONS OF SHEAR PLATES SHOWN ABOVE ARE PREFERRED LOCATIONS. THEY MAY NEED TO BE MOVED TO ACCOMMODATE COMPONENTS ON THE CHASSIS RAILS.**



# TITAN 60

## MOUNTING AND INSTALLATION

- Using the pre-drilled holes in the outrigger support, drill (3)21/32"Ø holes into chassis rail per side.
- Weld shear plates to the body frame.

**NOTE: FOLLOW CHASSIS RECOMMENDATIONS WHEN WELDING BODY COMPONENTS.**

- Bolt Body to Chassis Frame using 5/8" UNC Grade 8 Hardware (Bolt, Washer, Nut, Etc...) Torque to 180 Ft-Lbs

**Note: If you would like to mount the body using another method, please refer to the chassis manufacturer's body builder guide or the NTEA handbook.**

- Install Fenderettes (Supplied) to the body: (Reference figure below)
  - Wipe mounting surface with clean cloth to remove any dirt or oils.
  - Locate Fenderette to sidepack, aligning the bottom edges and centering it on fender well opening.
  - Draw lines on fender with oil pencil or other erasable marker to assist with alignment when adhesive is applied.
  - Apply adhesive to fenderette flange per instructions on cartridge. 1/8" bead in center of flange is recommended. The nozzle does not need to be cut to provide 1/8" bead.
  - Use lines from step 3 to locate fenderette to sidepack, aligning the bottom edges and centering it on the fender well opening as before.
  - Using wide surface area clamps, clamp fenderette into place to insure full contact between the fenderette flange and the sidepack.
  - Remove any excess adhesive from outer edges.
  - Allow adhesive to cure 3 to 4 hours before removing clamps. Adhesive will be fully cured in 8 to 24 hours.

(If you would like to paint the fenderette, you must use the following components. Surface must be cleaned with DuPont #3919S Prep-Sol or equivalent, Primed with Polypropylene primer (Ditzler DPX800 or equivalent), and use a flex additive (Ditzler DX369 or equivalent).

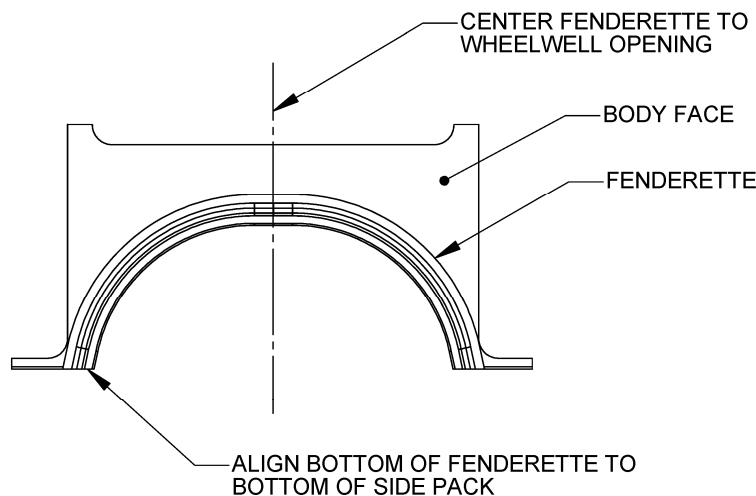

- Install wiring, lights, and reflectors onto body. Reference schematic on following page for wiring detail. Reference view at beginning of Mounting and Installation section for location of remaining components.

# TITAN 60 MOUNTING AND INSTALLATION

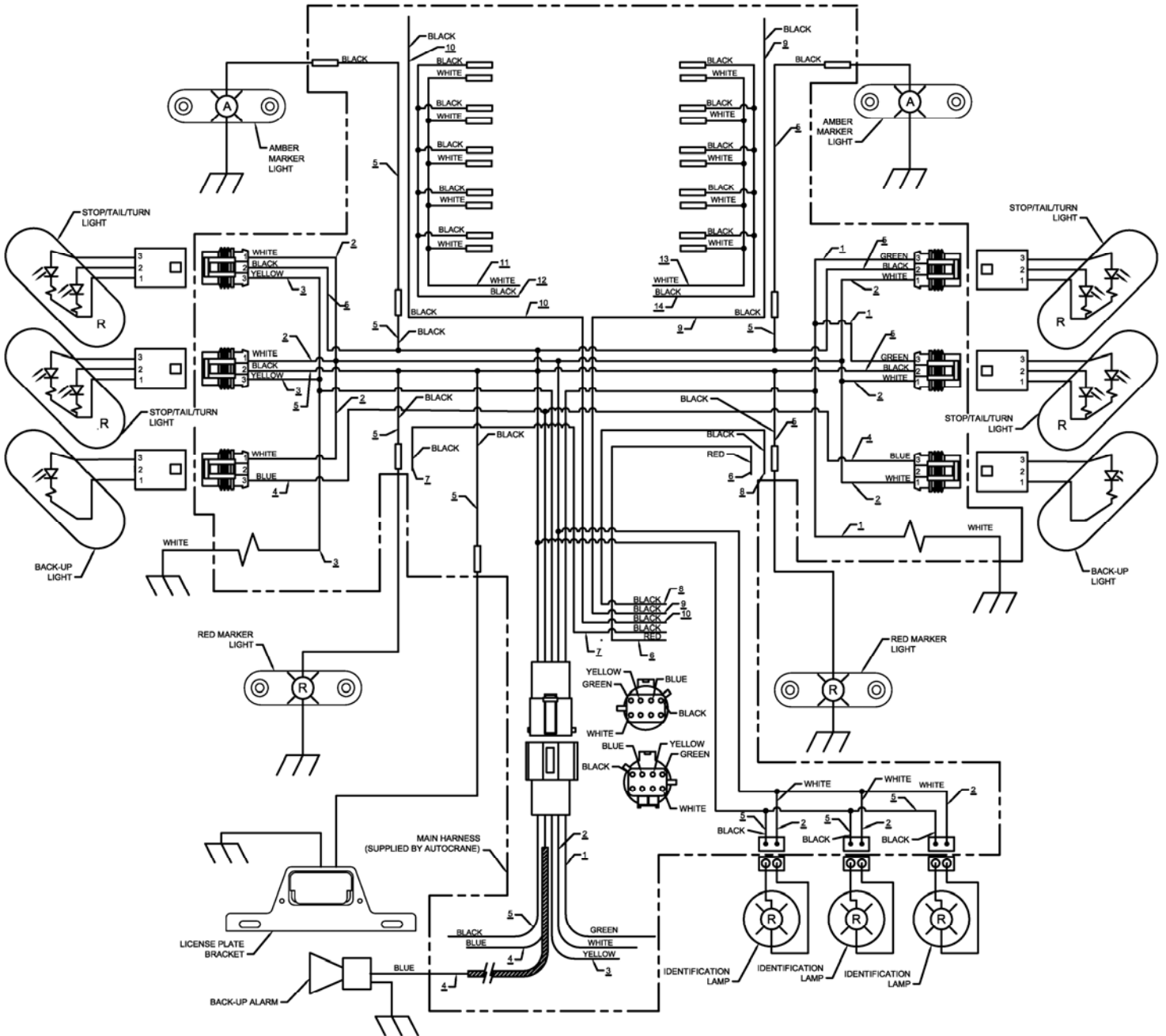

# **TITAN 60 MOUNTING AND INSTALLATION**

<b>WIRE #</b>	<b>COLOR</b>	<b>DESCRIPTION</b>	<b>LABEL</b>
1	GREEN	STOP/TURN SIGNAL RIGHT SIDE	
2	WHITE	GROUND	
3	YELLOW	STOP/TURN SIGNAL LEFT SIDE	
4	BLUE	BACK-UP SIGNAL	
5	BLACK	TAIL LIGHT SIGNAL	
6	RED	OPTIONAL HALOGEN SUPPLY WIRE	HALOGEN
7	BLACK	OPTIONAL REAR WORK LIGHT LEFT SIDE	WRK LT LFT
8	BLACK	OPTIONAL REAR WORK LIGHT RIGHT SIDE	WRK LT RT
9	BLACK	OPTIONAL LIGHTING RIGHT SIDE	OPTIONAL LIGHTING
10	BLACK	OPTIONAL LIGHTING LEFT SIDE	OPTIONAL LIGHTING
11	WHITE	INTERIOR COMPARTMENT LIGHT LEFT SIDE (OPTIONAL)	
12	BLACK	INTERIOR COMPARTMENT LIGHT LEFT SIDE (OPTIONAL)	
13	WHITE	INTERIOR COMPARTMENT LIGHT RIGHT SIDE (OPTIONAL)	
14	BLACK	INTERIOR COMPARTMENT LIGHT RIGHT SIDE (OPTIONAL)	

8. Install all accessories per their installation procedures. If unit has a hydraulic outrigger, you must follow the procedure shown on the following page to set the outrigger relief valve.
9. Verify final truck configuration meets all applicable federal guidelines. Reference 49CFR571.109
10. Read operating section of manual before operating the unit.

# **TITAN 60 MOUNTING AND INSTALLATION**

## **OUTRIGGER RELIEF VALVE SETTING INSTRUCTIONS**

For hydraulic powered outrigger control valves provided by AutoCrane

AutoCrane hydraulic powered outriggers utilize a control valve which contain an integral hydraulic relief valve that is preset at the factory. This preset is NOT the final setting and must be adjusted to account for hydraulic system backpressure once the installation is complete. The adjustment is straight forward and requires basic hand tools, thermometer or means to measure hydraulic oil temperature, and a hydraulic pressure gauge with a minimum rating of 5,000 psi and hydraulic fittings necessary to install the gauge in-line with the incoming pressure line to the outrigger control valve body.

Follow the procedure below to make the final adjustments to this relief valve.

1. The outrigger hydraulic relief valve should be adjusted to 200 psi above the crane hydraulic relief valve. Please consult the appropriate owner's manual for this setting or contact the crane manufacturer for this value.

### **WARNING!**

**Under no circumstances should this relief valve setting exceed any of the hydraulic system components ratings or limitations as component damage or personal injury may result.**

2. Install the hydraulic pressure gauge in-line with the incoming pressure line to the outrigger control valve body.
3. With all personnel clear of the vehicle, start the engine and engage the vehicle PTO. Let the hydraulic oil warm until it reaches 100°F.
4. While watching the hydraulic pressure gauge, activate a hydraulic outrigger function to deadhead the hydraulic system. Read the gauge value quickly and do not hold the function into the deadhead position.
5. Using the hand hold, back off the lock nut on the hydraulic relief valve and make small rotation adjustments (1/2 turn) to the relief valve stem.
6. Repeat step 4 to check if this adjustment meets the system requirements. If not, then repeat Step 5 and Step 4 until correct.
7. Tighten the lock nut on the hydraulic relief valve.
8. Remove the hydraulic pressure gauge and fittings and re-attach the pressure supply line to the hydraulic valve body.

# **TITAN 60**

## **VEHICLE OPERATION & PREPARATIONS**

### **IMPORTANT—READ FIRST!!**

#### **VEHICLE PREPARATION FOR OUTRIGGER AND CRANE OPERATION**

1. Park vehicle within crane operating distance from object that is to be lifted.

Notes:

- Make sure there are no obstructions preventing safe handling of load during crane operation.
  - Verify that no obstructions will prevent the full extension of the outrigger legs on both sides of vehicle.
  - Regardless of load to be lifted the outriggers should always be fully extended to keep vehicle stable.
  - Grade shall not exceed 1° of level. Level truck with blocks if grade exceeds 1° of level.
2. **ALWAYS** set the vehicle emergency brake before beginning crane operations.
  3. Use wheel chocks on the front wheels of vehicle.

#### **INSPECT OUTRIGGERS BEFORE USE**

1. Visually inspect outrigger before use making sure the outrigger is in good working order.
2. Replace or repair any worn or damaged parts before outrigger operation.
3. Check for and repair leaks on hydraulic units if they occur.

#### **MANUAL OUTRIGGER OPERATION**

1. Un-hook the sling from around the outrigger leg.
2. Extend outrigger slides from stowed position by releasing pull pin and extending the outrigger slides fully.
3. Make sure the slides are fully extended and locked into position with pull pin.
4. Lower both outrigger legs until they contact the ground then extend another inch to insure good ground contact.

Notes:

- Use blocks under pads to increase surface area if required for stability on soft ground.
- **DO NOT LIFT TRUCK WHEELS WITH OUTRIGGERS.** The outriggers are intended for vehicle stability during lifting operations not for complete vehicle support.

#### **MANUAL OUTRIGGER STOWING PROCEDURE**

5. Fully retract vertical legs to stowed position.
6. Retract outrigger slides from extended position by releasing pull pin and pushing slides in fully.
7. Make sure the slides are fully retracted and locked into position with pull pin.
8. Make sure the sling is secured in place around the outrigger leg.

# **TITAN 60**

## **VEHICLE OPERATION & PREPARATIONS**

### **HYDRAULIC OUTRIGGER OPERATION**

1. Divert hydraulic flow from control valve to outrigger operations.
2. Use the hydraulic control valve to extend outrigger slides from stowed position to the fully extended position.
3. Make sure the slides are fully extended.
4. Lower both outrigger legs until they contact the ground then extend another inch to insure good ground contact.

#### Notes:

- Use blocks under pads to increase surface area if required for stability on soft ground
- **DO NOT LIFT TRUCK WHEELS WITH OUTRIGGERS.** The outriggers are intended for vehicle stability during lifting operations not for complete vehicle support.

### **HYDRAULIC OUTRIGGER STOWING PROCEDURE**

5. Fully retract vertical legs in stowed position.
6. Retract outrigger slides from extended to the fully retracted position.
7. Make sure the slides are fully retracted in the stowed position.
8. Make sure the sling is secured in place around the outrigger leg.

# TITAN 60 DOOR

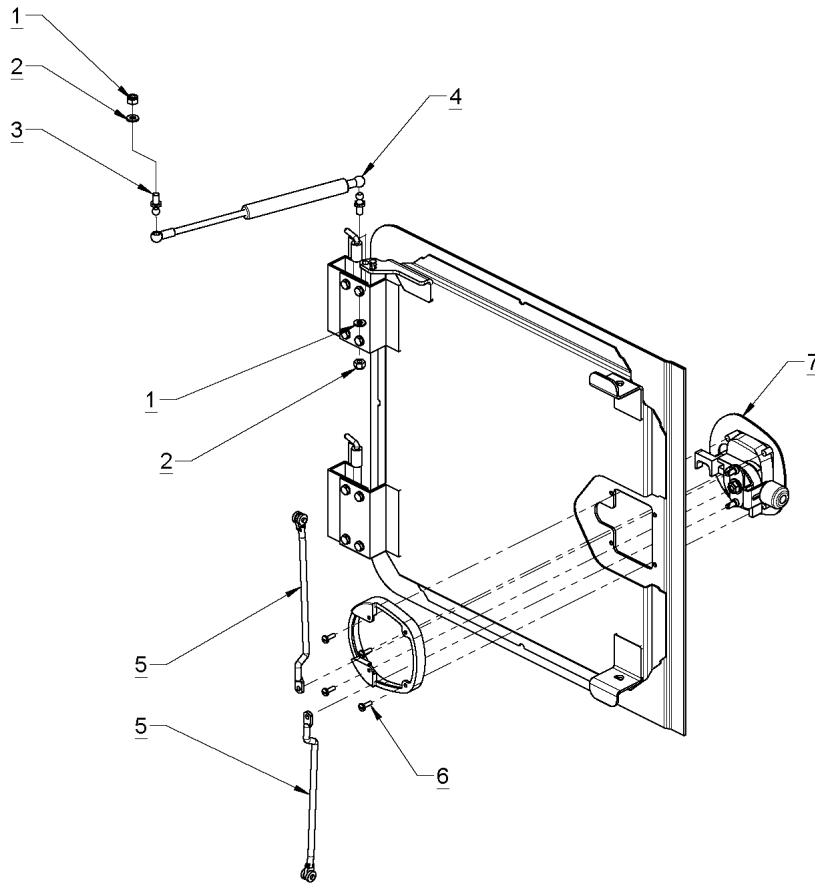

ITEM NO.	QTY	PART NUMBER	DESCRIPTION
1	2	016801000	NUT HX NYLK 5/16-18UNC CP
2	2	020300000	WASHER FL 1/4 CP
3	2	760535002	BALL STUD THREADED 5/16-18
4	1	760535001	DOOR PROP (GAS)
5	2	*SEE CHART	DOOR ROD
6	4	002609000	SCREW RD HD #10UNF X 5/8 CP GR3
7	1	560525000	T-HANDLE

USED ON	PART NUMBER	DESCRIPTION
USED ON ALL 52" COMPARTMENT DOORS, UPPER/LOWER	560101000	DOOR ROD STD
USED ON 58" COMPARTMENT DOORS, UPPER	560102000	DOOR ROD TALL
USED ON HORZ. COMP. LOWER	560103000	DOOR ROD HORIZ
USED ON HORZ. COMP. UPPER	560111000	DOOR ROD HORIZ TALL CAB STYLE

# TITAN 60 TAILGATE

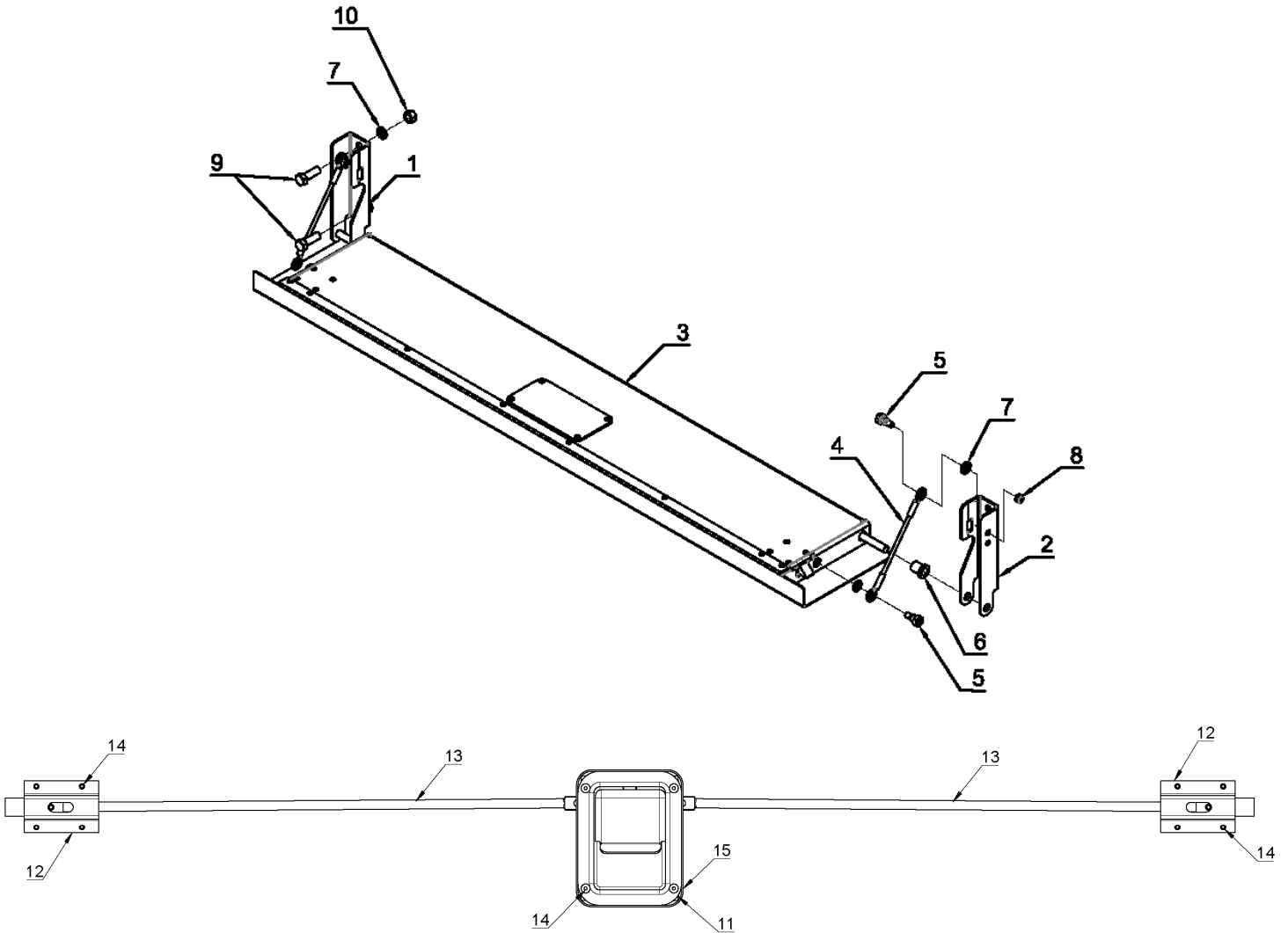

ITEM NO.	QTY	PART NUMBER	DESCRIPTION
1	1	560085000	MTG BRKT WDMT LH
2	1	560088000	MTG BRKT WDMT RH
3	1	560081000	TAILGATE SUB ASSY
4	2	560090000	CABLE ASSY TAILGATE
5	2	560091000	SCREW SHO SET 1/2 X 3/8
6	2	736738000	TAILGATE BUSHING
7	2	021403000	WASHER, FLAT-HARDENED 3/8
8	2	016801000	NUT HX NYLK 5/16-18UNC CP
9	4	010201000	SCREW HX HD 1/2UNC X 1 1/2 GR5
10	4	177010000	NUT HX 1/2 NCCP
11	1	560093000	LATCH ASSY TAILGATE
12	2	560094000	LATCH
13	2	560096000	ROD 3/8
14	12	754028000	RIVET 3/16 POP .251-.375 GRIP SS
15	1	560098000	GASKET



# OUTRIGGER ASSY, FULLY MANUAL GENERAL DIMENSIONS

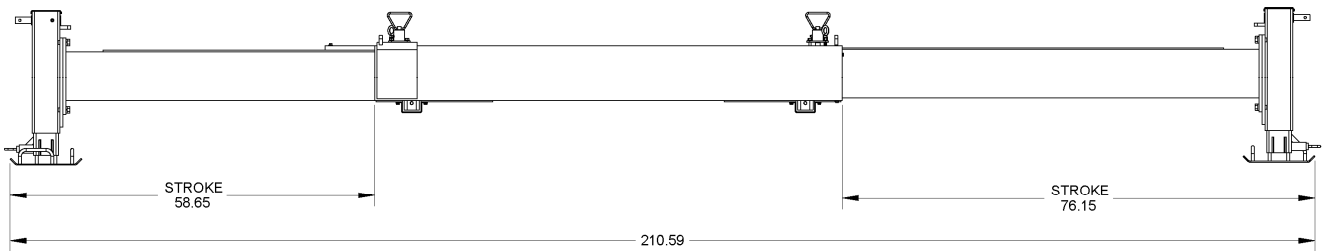
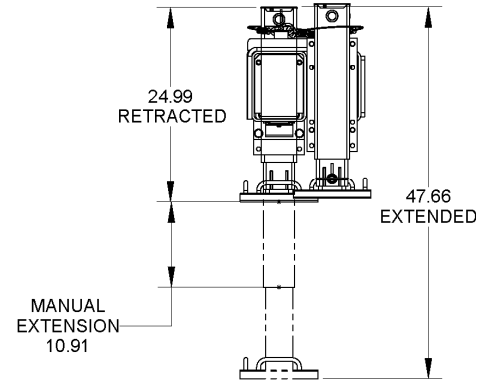
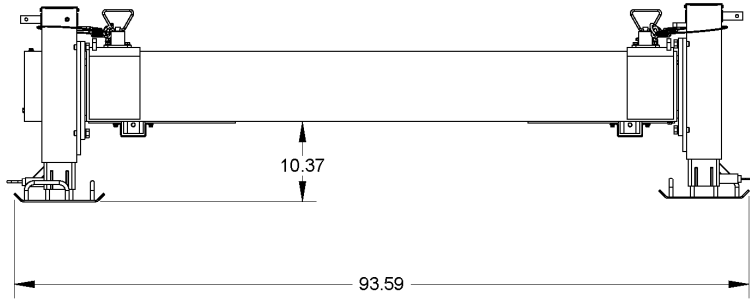

# OUTRIGGER ASSY, FULLY HYDRAULIC GENERAL DIMENSIONS RIGHT SIDE CRANE

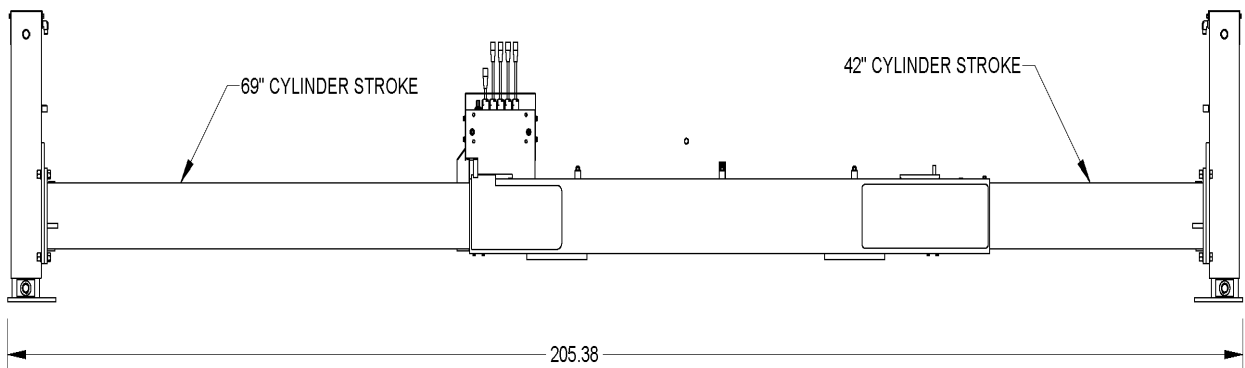
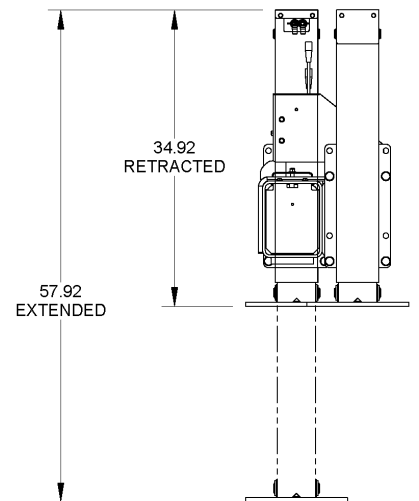
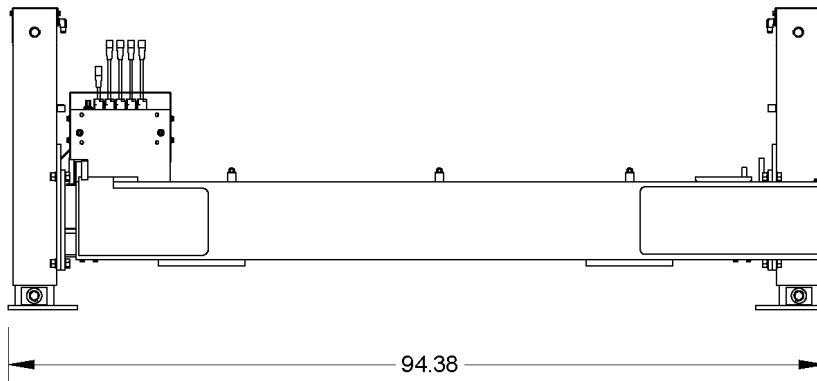
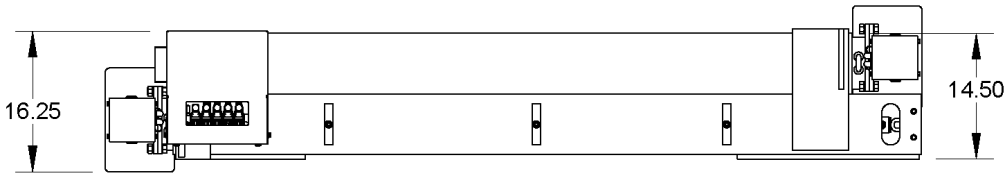

# OUTRIGGER ASSY, FULLY HYDRAULIC GENERAL DIMENSIONS LEFT SIDE CRANE

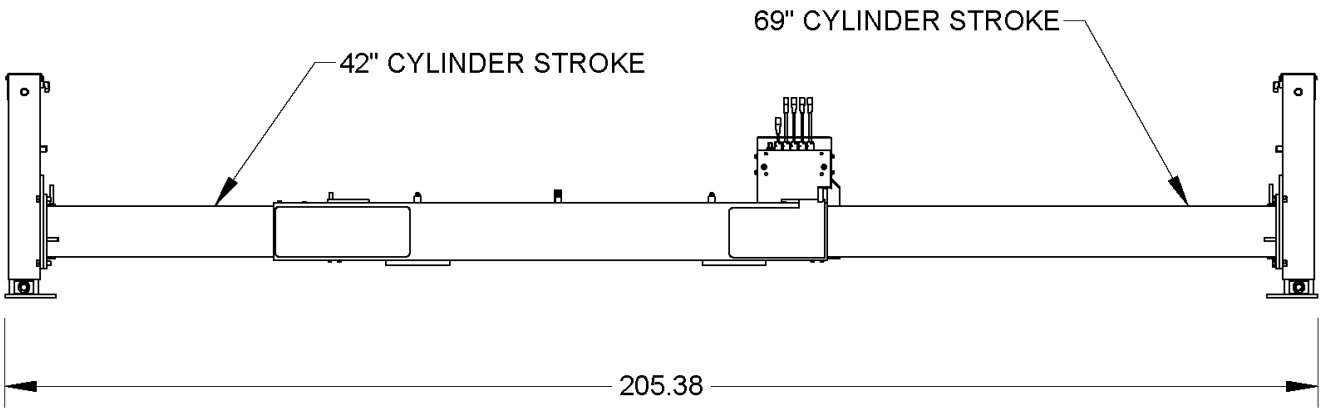
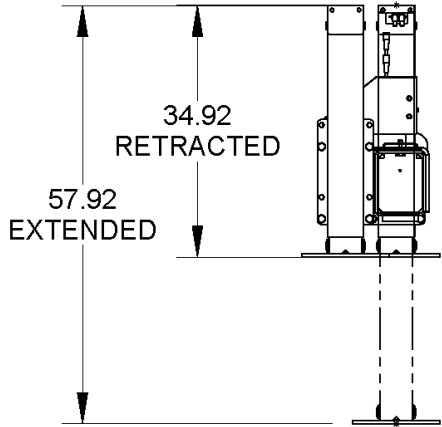
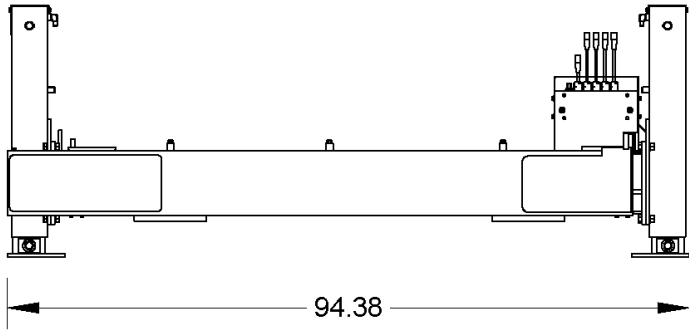
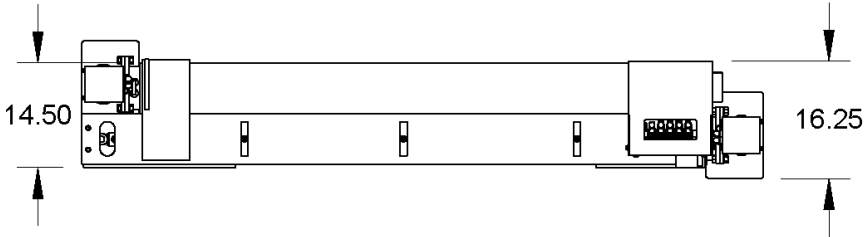

OUTRIGGER EXTENDED

# TITAN 60 OUTRIGGER SHIP KIT

## MANUAL OUTRIGGER SHIP KIT 772090000

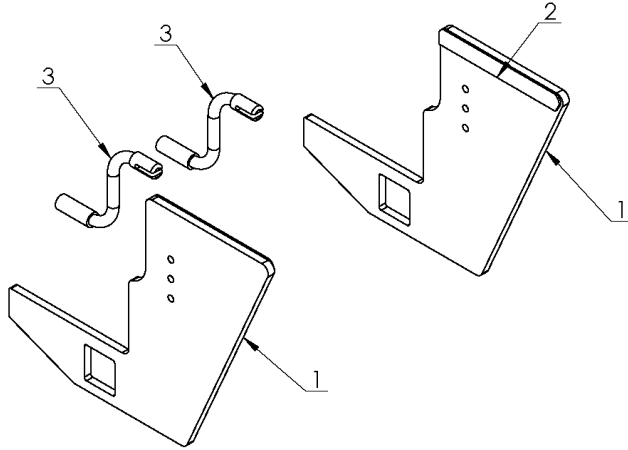

ITEM NO.	QTY	PART NUMBER	DESCRIPTION
1	2	760288001	OUTRIGGER SUPPORT PLATE F/HITCH
2	2	750989000	SPACER, OUTRIGGER SUPPORT, TITAN 50, 60, 70
3	2	480445000	HANDLE MANUAL

## HYDRAULIC OUTRIGGER SHIP KIT 772089000

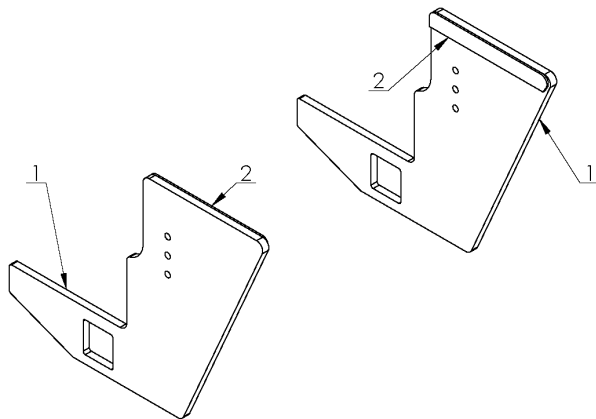

ITEM NO.	QTY	PART NUMBER	DESCRIPTION
1	2	760288001	OUTRIGGER SUPPORT PLATE F/HITCH
2	2	750989000	SPACER, OUTRIGGER SUPPORT, TITAN 50, 60, 70

# TITAN 60 OUTRIGGER INSTALLATION

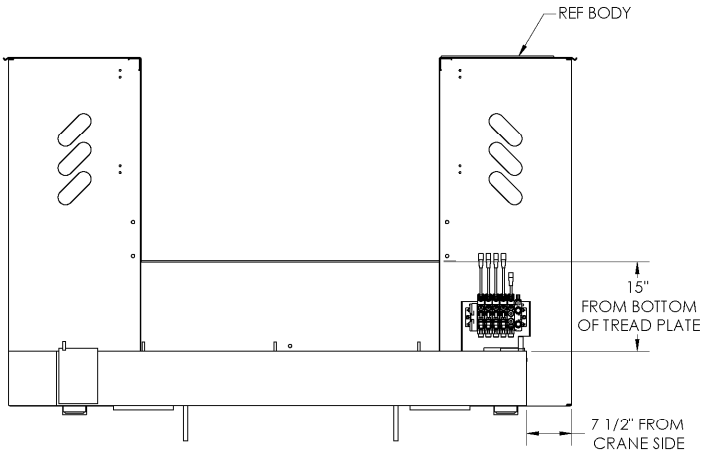

**CROSS TUBE LOCATION  
HYDRAULIC OUTRIGGER**

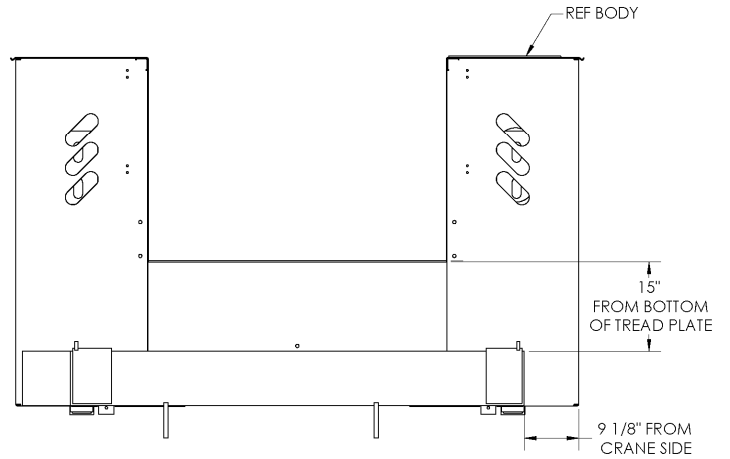

**CROSS TUBE LOCATION  
MANUAL OUTRIGGER**

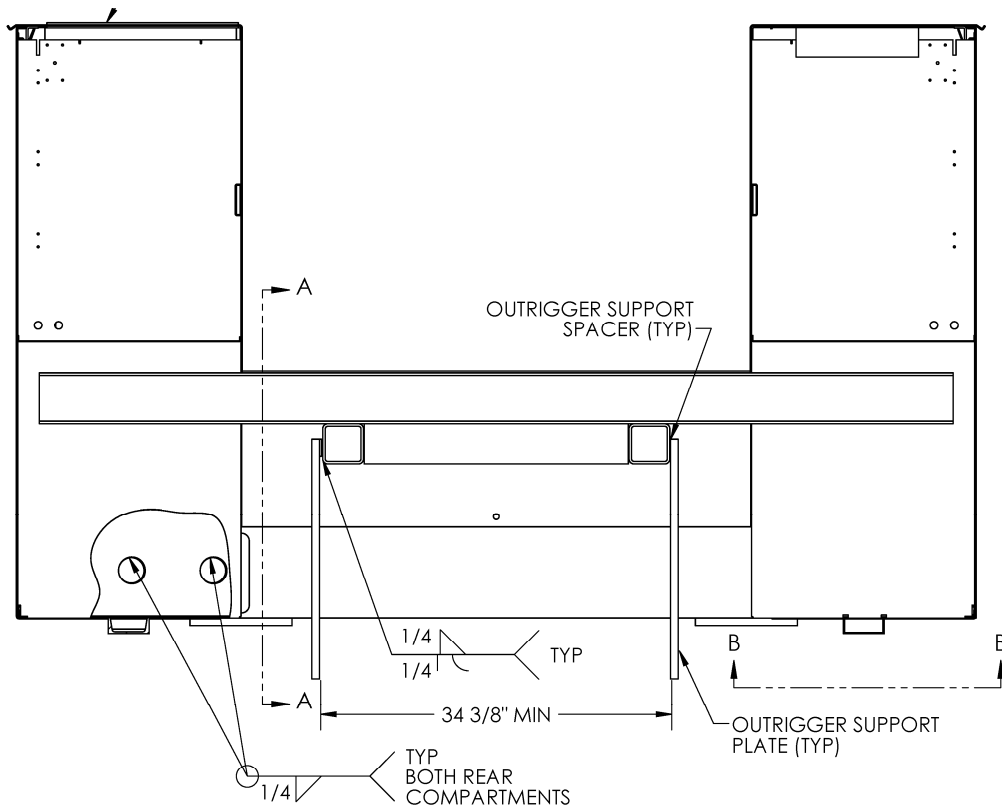

**SECTION VIEW FROM INSIDE FENDER WELL  
TOWARD BACK OF BODY**

# ***NOTES***

# OUTRIGGER ASSY, FULLY MANUAL

PN: 760431000

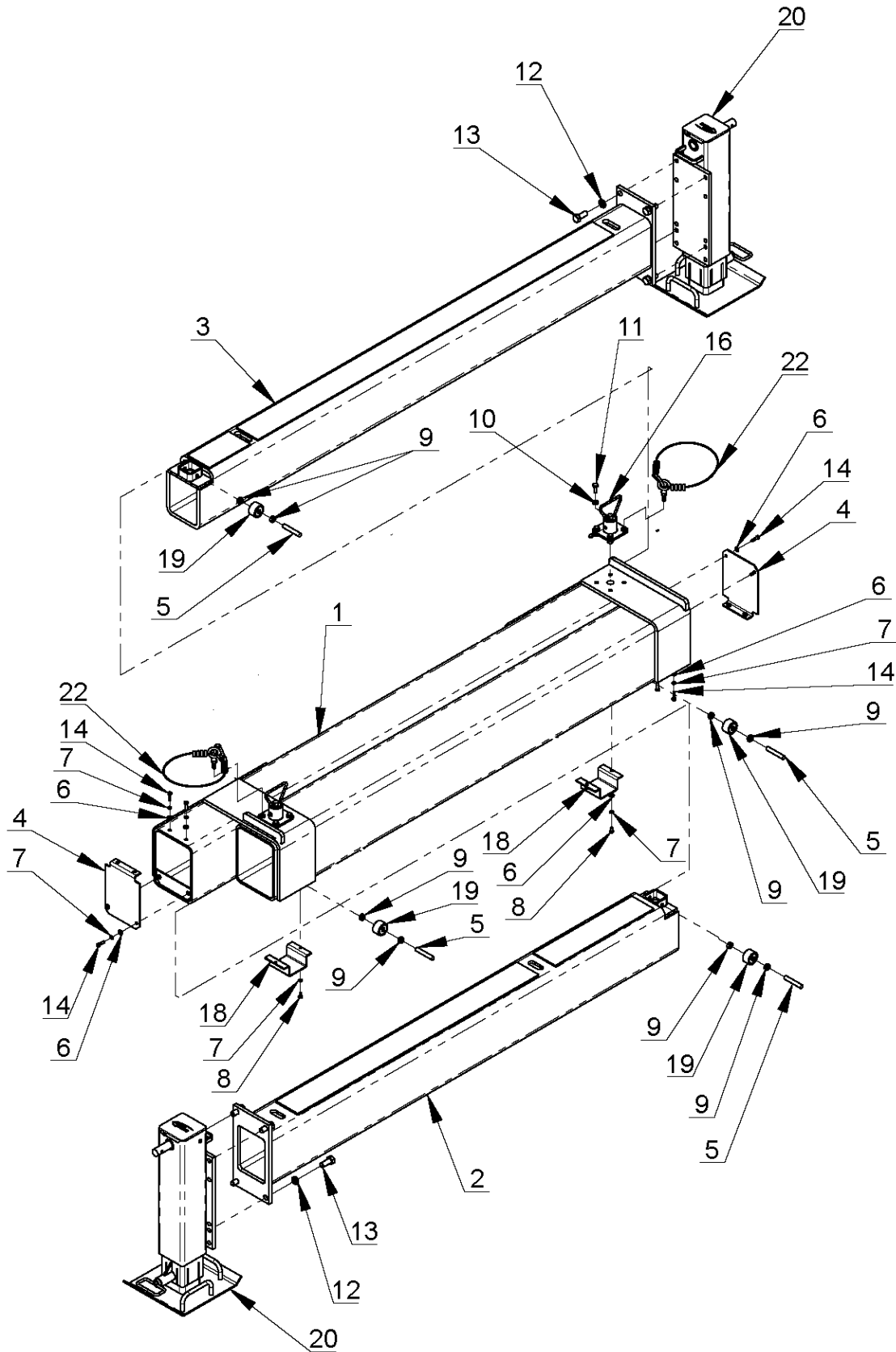

**OUTRIGGER ASSY, FULLY MANUAL**  
**PN: 760431000**

ITEM NO.	QTY	PART NUMBER	DESCRIPTION
1	1	760384001	MAIN CROSS TUBE WDMT, MANUAL TITAN 60/70
2	1	760381001	SLIDE TUBE WELDMENT, SHORT
3	1	760380001	SLIDE TUBE WELDMENT, LONG
4	2	760284000	COVER ASSEMBLY, OUTRIGGER TUBE
5	4	372218000	SCREW SET 1/2-13UNC X 3 LG
6	12	204000000	WASHER FL SAE 1/4
7	12	202000000	WASHER SP LK 1/4
8	4	590100000	SCREW HX HD 1/4-20UNC X 1/2 LG
9	8	372219000	NUT, HX JAM 1/2-13UNC
10	8	211000000	WASHER SP LK 3/8
11	6	870100000	SCW HX 3/8 UNC X 1 GR5
12	8	238000000	WASHER SP LK 5/8
13	8	490172000	SCREW HX HD 5/8-11UNC X 1 1/2 LG
14	8	560400000	SCREW HX HD 1/4-20UNC X 1 LG
15	1	760245000	DECAL INSTALLATION, TITAN 60
16	2	760390110	3/4 PULL PIN WELD W/ MTG BRACKET
17	2	239300000	ZERK, GREASE
18	2	372216000	COVER ROLLER
19	4	240234000	BEARING, NEEDLE
20	2	759950000	OUTRIGGER LEG, MANUAL, TITAN 50
21	1	760290000	INSTALLATION DRAWING, TITAN 60 OUTRIGGER
22	2	772067000	SLING, OUTRIGGER



# OUTRIGGER ASSY, FULLY HYDRAULIC

## PN: 77202XXXX

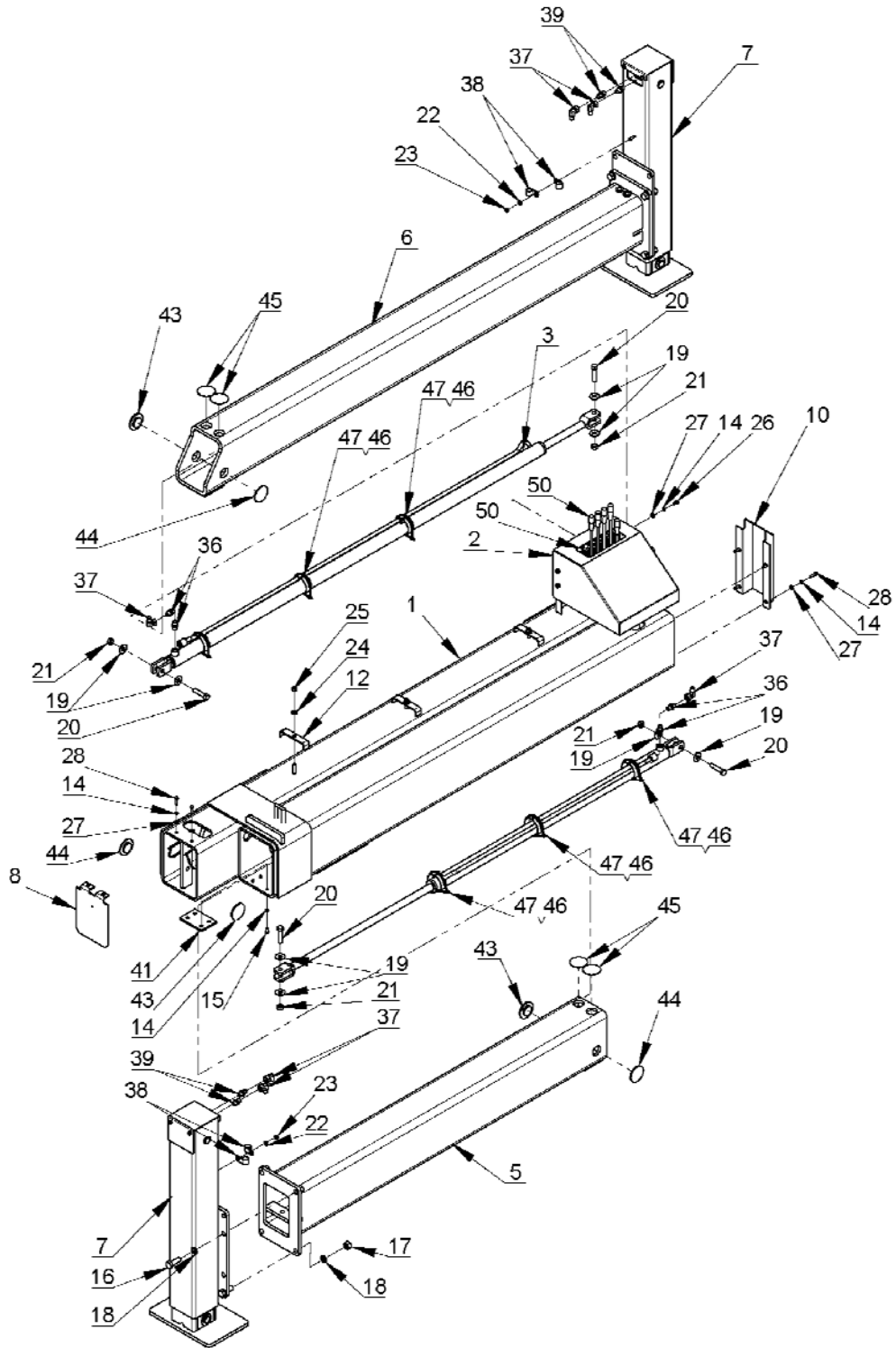

# OUTRIGGER ASSY, FULLY HYDRAULIC RIGHT SIDE PN: 772020000

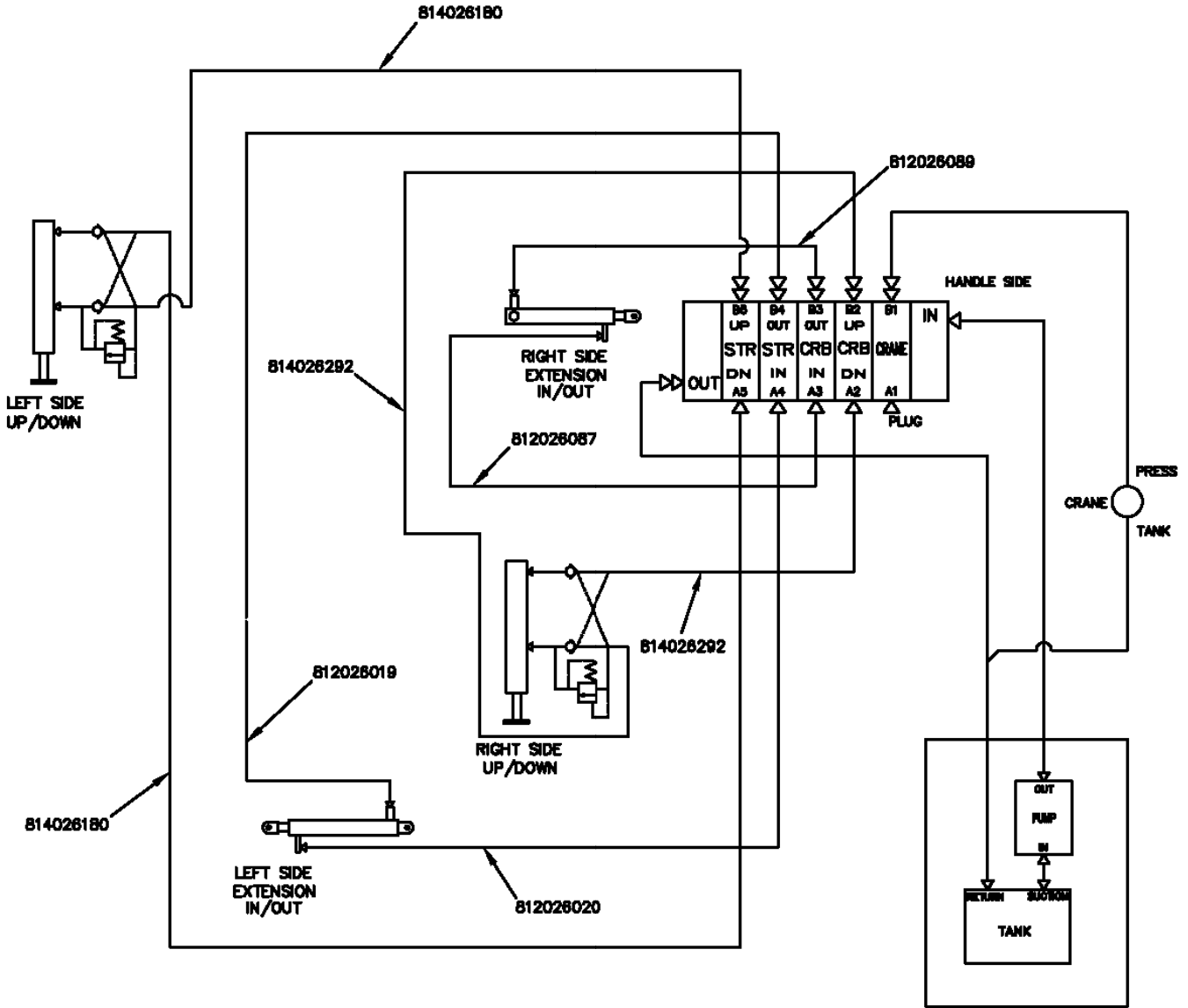

# OUTRIGGER ASSY, FULLY HYDRAULIC LEFT SIDE PN: 772021000

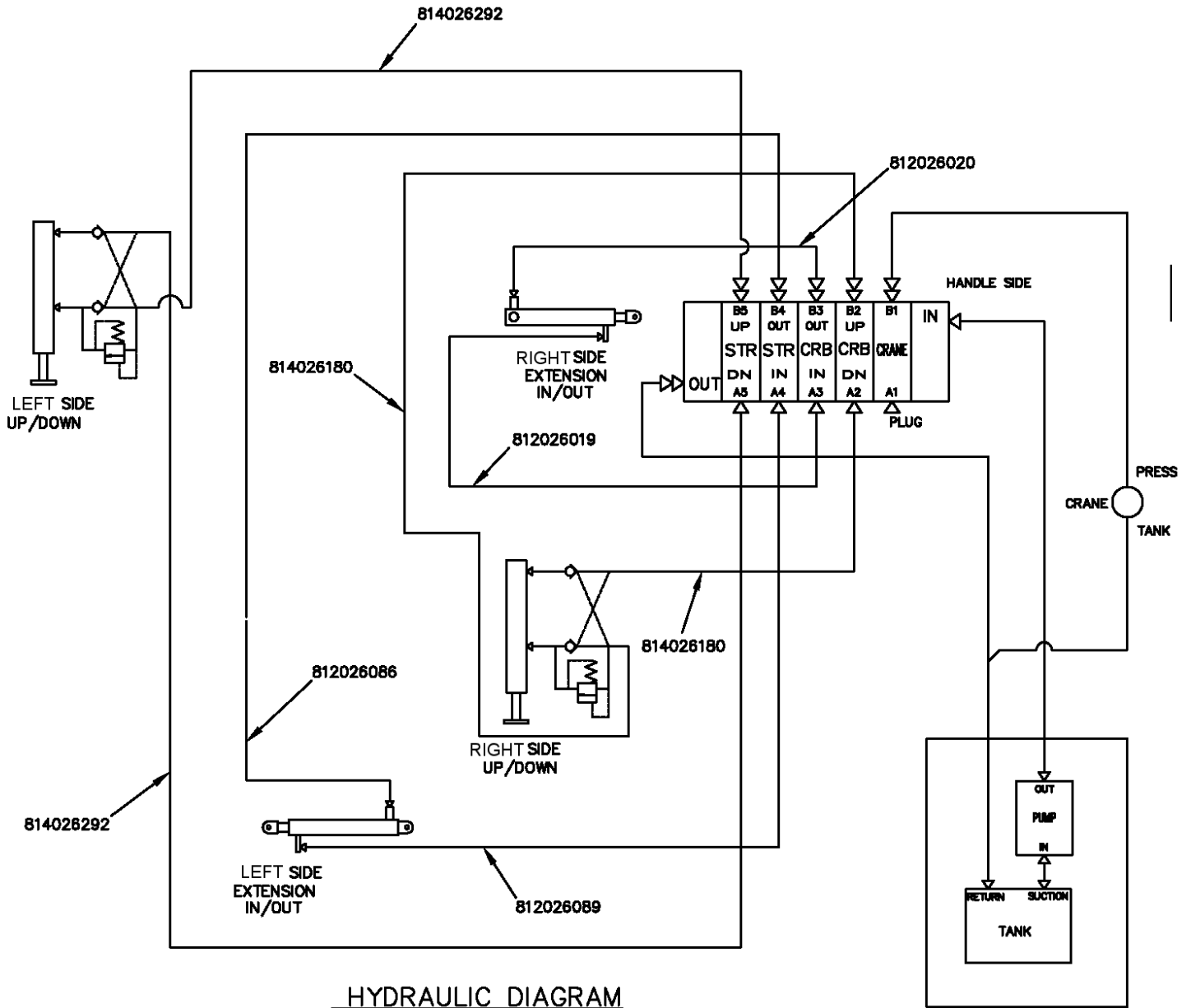

# OUTRIGGER ASSY, FULLY HYDRAULIC

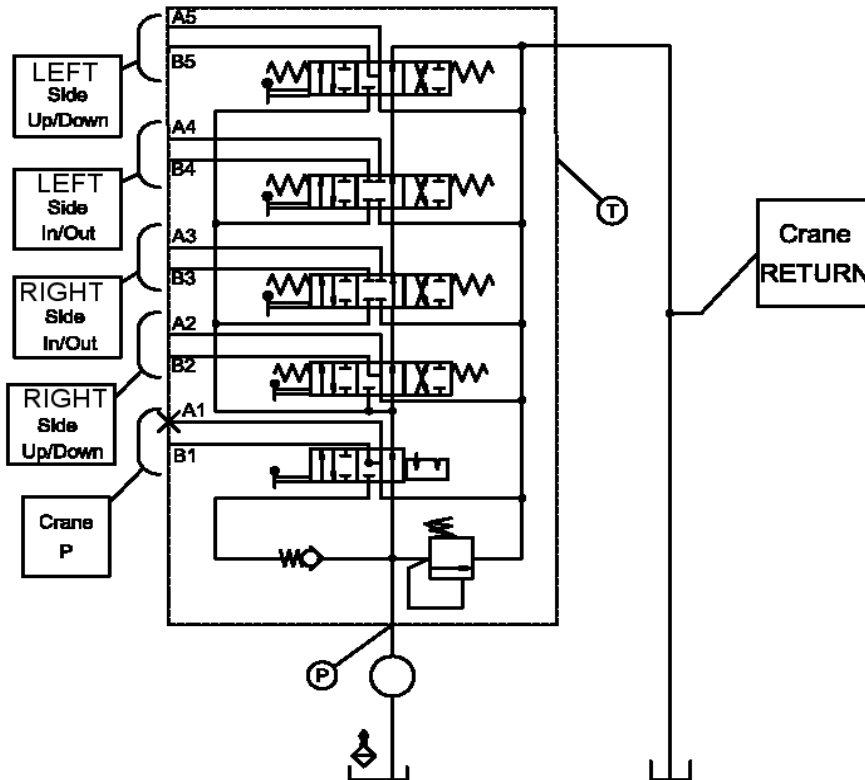

HYDRAULIC SCHEMATIC

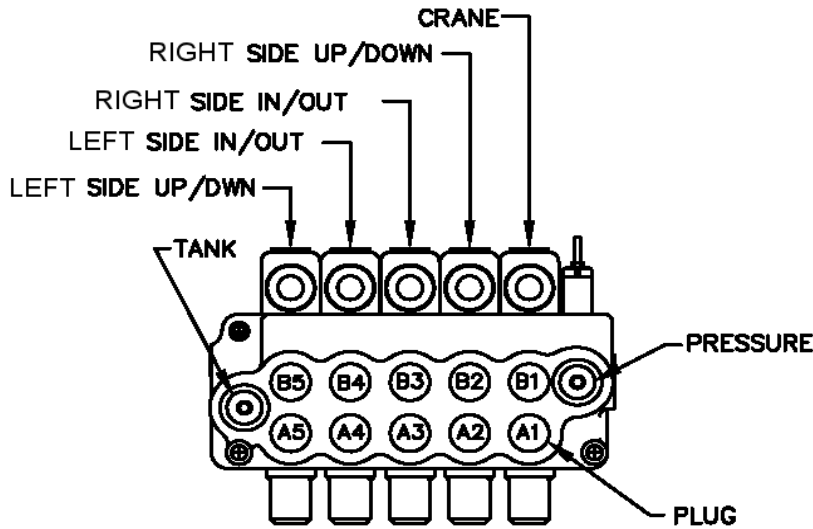

REAR VIEW

DIRECTION CONTROL VALVE

**NOTE:**

A-PORT BOTTOM

B-PORT HANDLE SIDE

# OUTRIGGER ASSY, FULLY HYDRAULIC BOM PN 77202XXXX

ITEM NO.	RS-0000	LS-1000	PART NUMBER	DESCRIPTION
1	0	1	772065000	MAIN CROSS TUBE WELDMENT, TITAN 60/70, LSC
	1	0	772030000	MAIN CROSS TUBE WELDMENT, TITAN 60/70, RSC
2	0	1	760223000	VALVE COVER, LSC TITAN 60
	1	0	760268000	VALVE COVER, TITAN 60
3	1	1	772023000	CYLINDER, 1.5 BORE, 69 IN STROKE
4	1	1	772024000	CYLINDER, 1.50 BORE X 42 STROKE X 1.00 ROD
5	0	1	772045000	SLIDE WELD, SHORT, LSC, T60/70
	1	0	772034000	SLIDE WELD SHORT, RSC, T60/70
6	0	1	772044000	SLIDE WELD, LONG, LSC, T60/70
	1	0	772022000	SLIDE WELD, LONG, RSC, T60/70
7	1	2	772029000	VERTICAL LEG ASSY, TITAN 60/70
8	1	1	760417000	COVER ASSEMBLY, OUTRIGGER TUBE
9	1	1	760248000	BRACKET ASSEMBLY, COVER
10	1	1	760249000	COVER, HOSE
11	18	18	374086000	NYLON HOSE SLEEVE
12	3	3	407216000	HOSE RETAINER, 4.75 WIDE
13	4	4	736272000	NUTSERT 1/4-20UNC X .027-.165 GRIP
14	18	18	202000000	WASHER SP LK 1/4
15	8	8	510200000	SCREW HX HD 1/4-20UNF X 5/8 LG
16	8	8	12198000	SCREW HX HD 5/8-11UNC X 1 3/4 LG GR8
17	8	8	407315000	NUT HX 5/8 NC CP GR8
18	16	16	239020000	WASHER FL 5/8 HARDENED
19	8	8	216000000	WASHER FL 1/2
20	4	4	11511000	SCREW HX HD 1/2-20UNF X 2 1/4 LG GR5
21	4	4	177010000	NUT HX 1/2-13UNC
22	2	2	209010000	WASHER FL 5/16
23	2	2	165000000	NUT HX 5/16-18UNC
24	3	3	212000000	WASHER FL 3/8
25	3	3	173010000	NUT HX NYLK 3/8-16UNC CP
26	4	4	540100000	SCREW HX HD 1/4-20UNC X 5/8 LG CP
27	10	10	204000000	WASHER FL SAE 1/4
28	6	6	560400000	SCREW HX HD 1/4-20UNC X 1 LG
29	1	1	772035000	HYDRAULIC KIT TITAN 60/70

# **OUTRIGGER ASSY, FULLY HYDRAULIC BOM PN 77202XXXX**

<b>ITEM NO.</b>	<b>RS-0000</b>	<b>LS-1000</b>	<b>PART NUMBER</b>	<b>DESCRIPTION</b>
30	2	2	814026180	HOSE ASSY, R7, -6JICF/-6JICF X -4 HOSE, 302"L
31	2	2	814026292	HOSE ASSY, R7, -6JICF/-6JICF X -4 HOSE, 302"L
32	1	1	812026019	HOSE ASSY, -6JICF/-6JICF, -4 HOSE
33	1	1	812026020	6 FEMALE JIC/6 FEMALE JIC, 20 INCHES LONG
34	1	1	812026087	HOSE ASSY, -6JIC/-6JICF x -4 HOSE
34	1	1	812026089	HOSE ASSY, -6JICF/-6JICF x -4 HOSE
35	4	4	760203000	FITTING, STR, -6 SAE/6 JIC RESTRICTED
36	6	6	480194000	FITTING 6 SWIVEL NUT ELBOW
37	4	4	480024000	MOUNT PENDANT CABLE RETAINER
38	4	4	200876000	FITTING 6 SAE/6 JIC STRAIGHT
39	26	26	760229000	TRIM EDGE, 5/16
40	2	2	772033000	PAD, 4.25 X 3.0 X .25, 1/4-28 NUTS
41	4	4	772027000	GROMMET, RUBBER, 1/2" ID, 1/2" THICK
42	4	4	407202000	PAD BOOM 2.50 O.D.
43	4	4	560356000	PAD BOOM 2.50 OD x .125
44	4	4	470048000	PAD, BOOM 2.50 O.D. X 0.063 THICK
45	8	8	772042000	RUBBER STRIP, 1 X 8 X .06
46	12	12	772043000	ZIP TIE STRAP, 12 IN, NYLON, BLACK
47	7	7	772046006	SPIRAL HOSE WRAP, 1/2", 6" LONG
48	1	1	760245000	DECAL INSTALLATION, TITAN 60
49	1	1	760260010	VALVE, 5 SPOOL W/RELIEF

# OUTRIGGER HYDRAULIC LEG ASSEMBLY TITAN SERIES—P/N 772029000

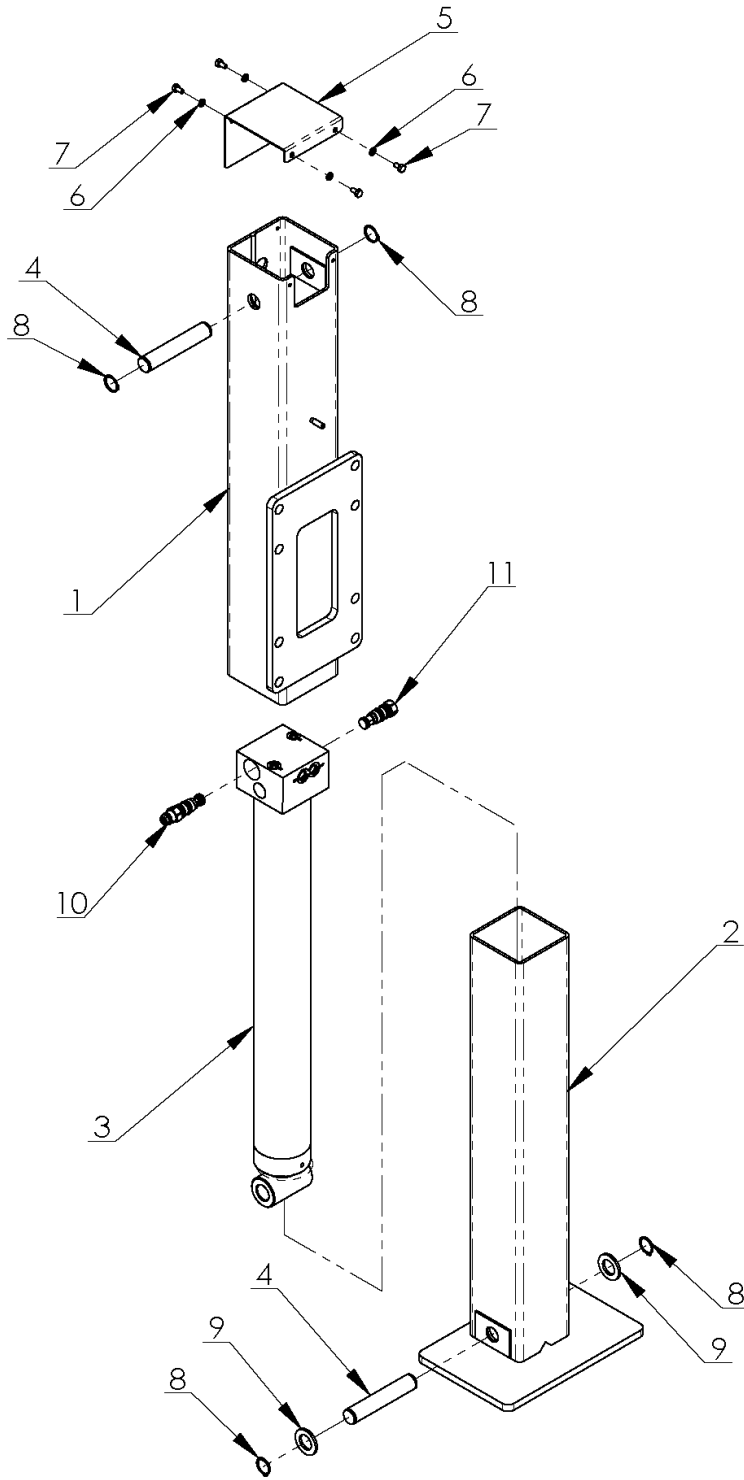

# OUTRIGGER HYDRAULIC LEG ASSEMBLY TITAN SERIES—P/N 772029000

ITEM NO.	QTY	PART NUMBER	DESCRIPTION
1	1	772038000	LEG WELDMENT, UPPER, T60/70
2	1	560150001	LOWER OUTRIGGER WDMT
3	1	560550000	CYLINDER, 3.00 BORE X 23.00, STROKE X 2.50 ROD
4	2	560367000	PIN 1 $\varnothing$ X 5.438 LG
5	1	560156001	COVER OUTRIGGER
6	4	202000000	WASHER SP LK 1/4
7	4	590100000	SCREW HX HD 1/4-20UNC X 1/2 LG
8	4	738734000	RING RETAINING 5100-100
9	2	560562000	WASHER, FL 1.03ID x 1.75OD x .156 THICK ZINC YELL
*10	1	480186000	SPOOL ASSY F/480184
*11	1	480231001	VALVE CARTRIDGE (30 PSI CRACKING PRESSURE)
*	PART OF 560550000 CYLINDER		



# RECEIVER HITCH INSTALLATION TITAN SERIES

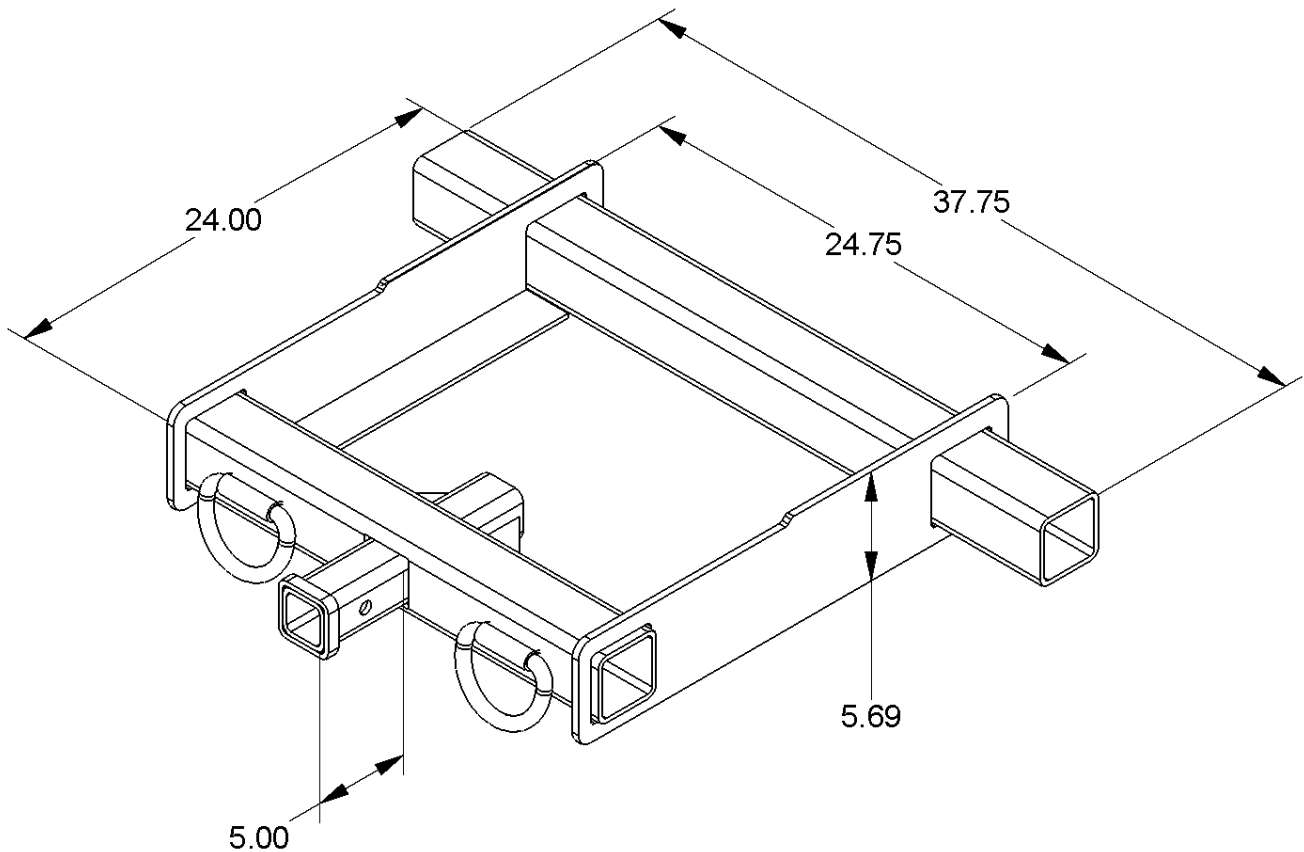

## **SPECIFICATIONS:**

12,000 LBS RATING

3" OPENING

**THIS HITCH IS FOR USE WITH A 30" BUMPER.**

# RECEIVER HITCH INSTALLATION TITAN SERIES

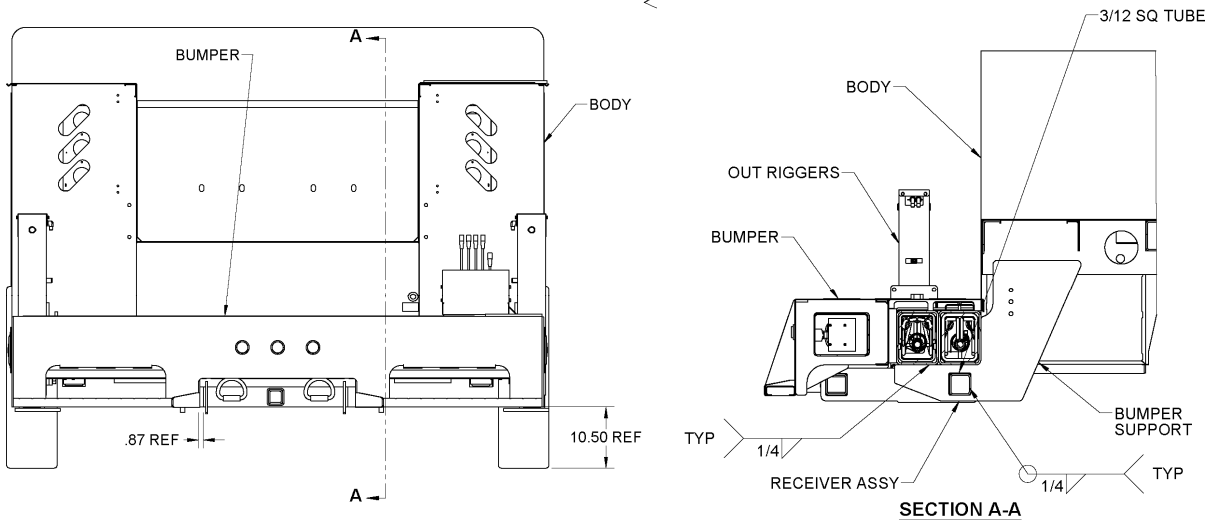
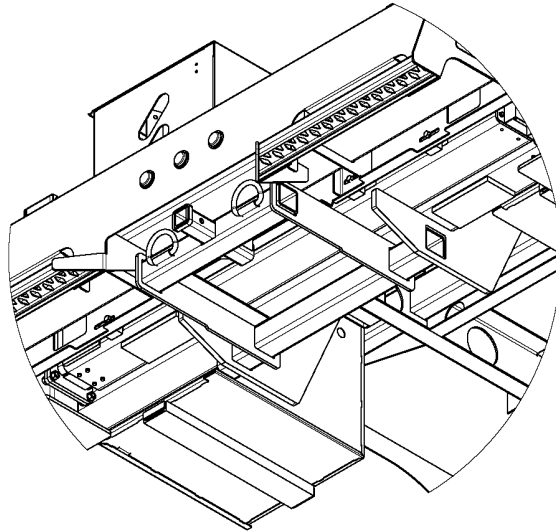

**NOTE:**

1. INSERT THE END OF THE 3 1/2" TUBE OF THE RECEIVER ASSY IN THE HOLE OF THE BUMPER SUPPORT.
2. CONTINUE TO SLIDE RECEIVER ASSY OVER AND INSERT THE OTHER END OF THE TUBE IN THE OTHER BUMPER SUPPORT.
3. LOCATE THE RECEIVER ASSY AS SHOWN AND WELD INTO PLACE.
4. ALSO WELD THE RECEIVER ASSY TO THE BOTTOM OF THE OUTRIGGER TUBE AS SHOWN.

# TITAN 60 BUMPER INSTALLATION

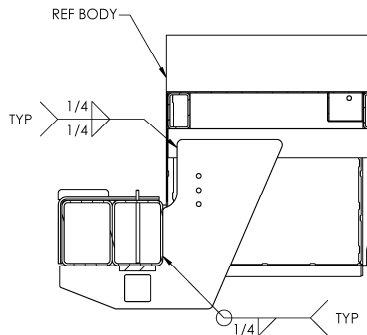

**SECTION A-A**

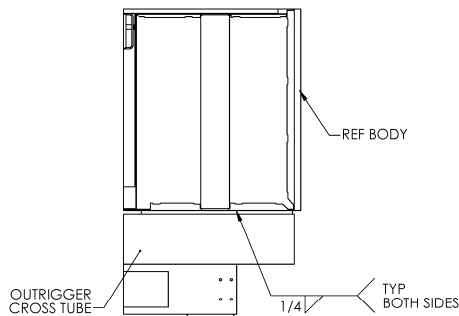

**SECTION B-B**

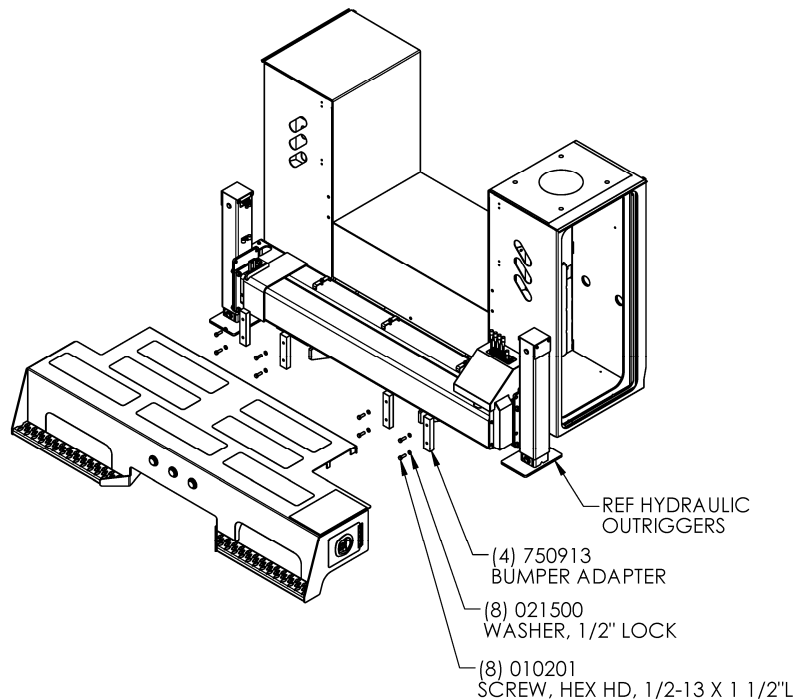
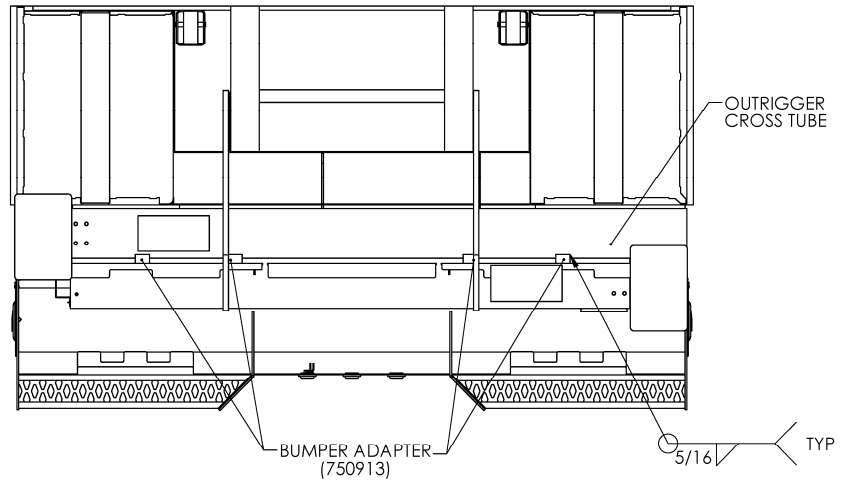

## BUMPER INSTALLATION INSTRUCTIONS

- 1) ATTACH THE (4) BUMPER ADAPTERS (750913) WITH 1/2" BOLT (010201) AND 1/2" LOCK WASHER (021500).
- 2) PLACE THE BUMPER IN PLACE WITH THE BUMPER ADAPTERS AGAINST THE OUTRIGGER CROSS TUBE AND THE BUMPER TOP PLATE RESTING ONTOP OF THE CROSS TUBE.
- 3) SQUARE AND CENTER THE BUMPER TO THE REAR OF THE BODY, THEN TACK WELD THE ADAPTERS TO THE CROSS TUBE.
- 4) REMOVE THE BUMPER BY REMOVING THE 1/2" HARDWARE.
- 5) WELD ALL (4) ADAPTERS WITH A 5/16 FILLET WELD ALL AROUND.
- 6) REINSTALL BUMPER WITH 1/2" HARDWARE.

# BUMPER ASSEMBLY 30", MANUAL TITAN 60/70 - P/N: 772080000

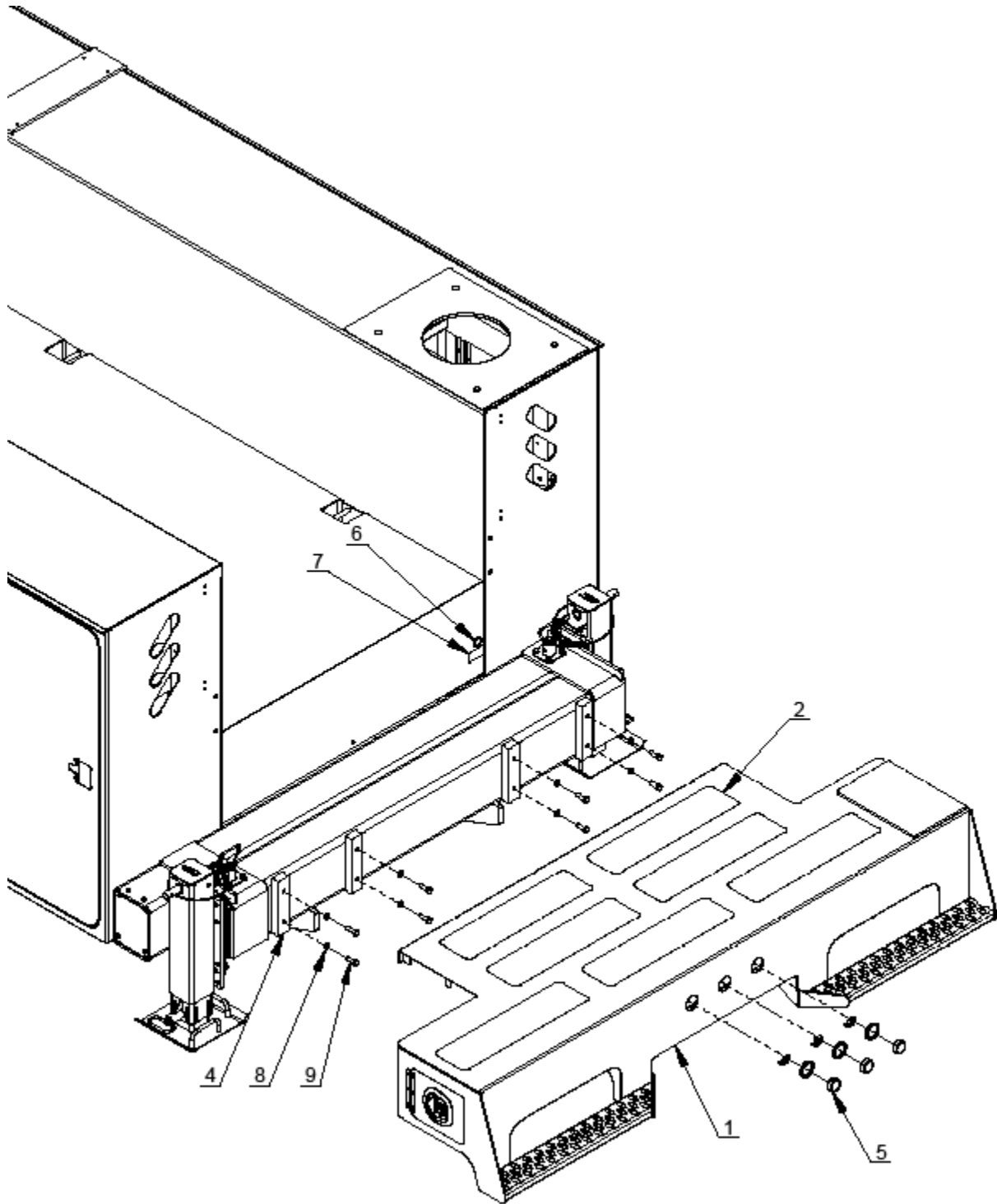

# **BUMPER ASSEMBLY 30", MANUAL TITAN 60/70 - P/N: 772080000**

FOR USE WITH THE 760431000 MANUAL OUTRIGGER

ITEM NO.	QTY	PART NUMBER	DESCRIPTION
1	1	772081000	BUMPER WELDMENT MANUAL
2	7	766141000	DECAL, SAFTEY SURFACE
3	1	560245002	KIT, SHIP BUMPER
*4	4	750913000	BUMPER ADAPTER
*5	3	560105000	LIGHT MARKER LED 2"
*6	1	750282000	GROMMET 1 3/8 OD
*7	12"	752269000	TRIM EDGE
*8	8	21500000	WASHER SP LK 1/2
*9	8	12010000	SCREW HX HD 1/2 -13UNC X 1 1/2LG
*	ITEM PART OF ITEM #3		

# BUMPER ASSEMBLY 30", HYDRAULIC TITAN 60/70

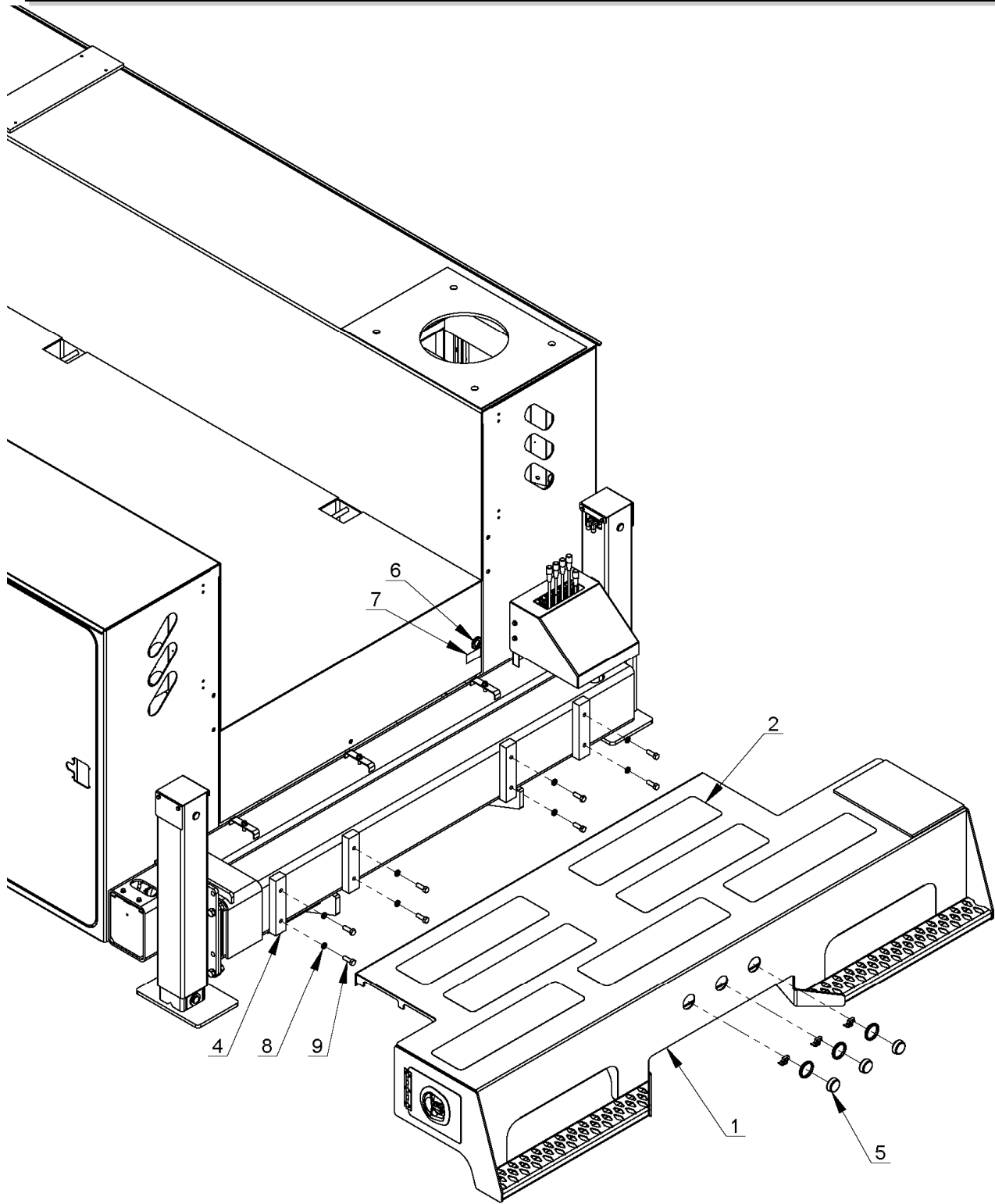

# **BUMPER ASSEMBLY 30", HYDRAULIC TITAN 60/70**

ITEM NO.	LCS	RSC	PART NUMBER	DESCRIPTION
1	1	0	772064000	BUMPER WELMENT, LSC
	0	1	772060000	BUMPER WELMENT, RSC
2	7	7	766141000	DECAL, SAFTEY SURFACE
3	1	1	560245002	KIT, SHIP BUMPER
*4	4	4	750913000	BUMPER ADAPTER
*5	3	3	560105000	LIGHT MARKER LED 2"
*6	1	1	750282000	GROMMET 1 3/8 OD
*7	12"	12"	752269000	TRIM EDGE

RIGHT SIDE CRANE SHOWN  
LEFT SIDE CRANE OPPOSITE

P/N 772069000  
P/N 772063000

# MASTER LOCK SYSTEM TITAN SERIES 84CA - P/N: 560205000

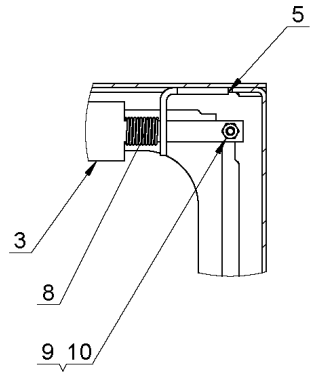
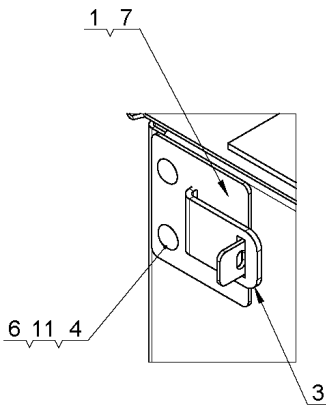

**DETAIL B**

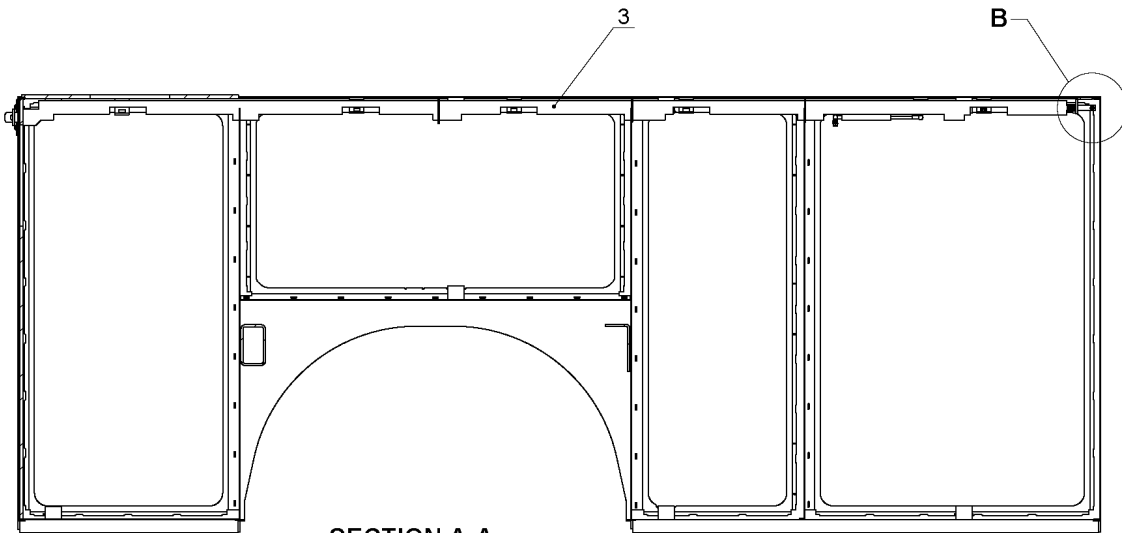

**SECTION A-A**

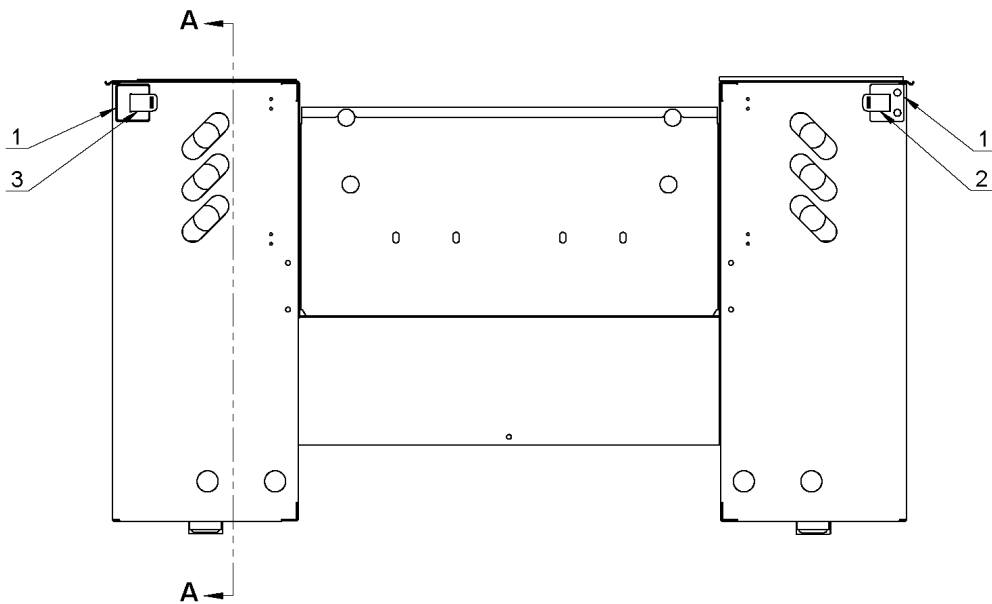



# **MASTER LOCK SYSTEM** **TITAN SERIES 120CA - P/N: 760551000**

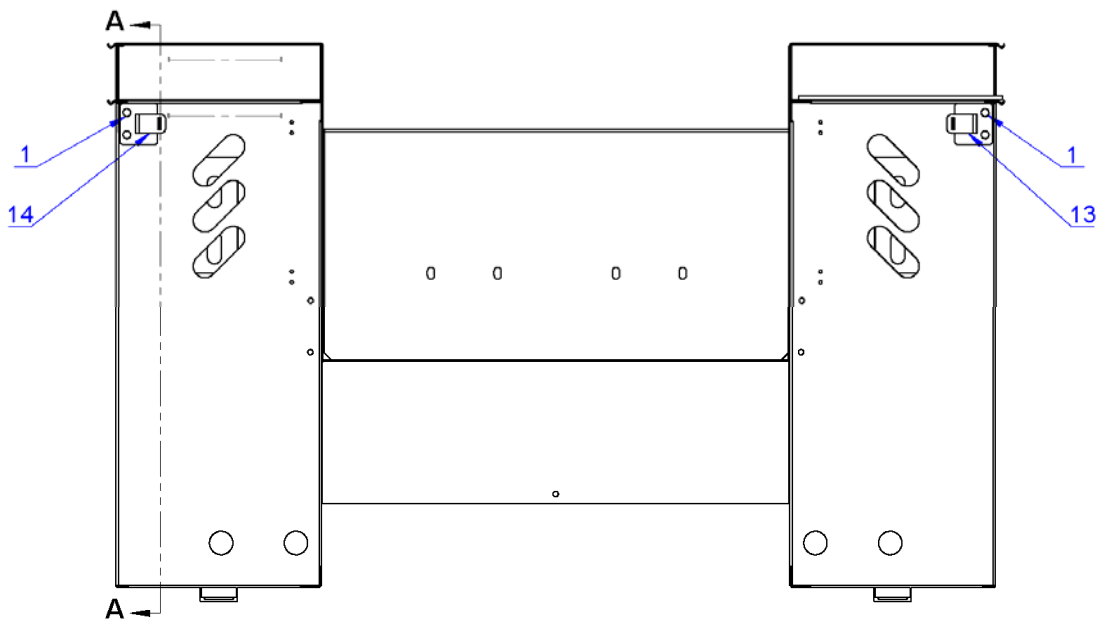
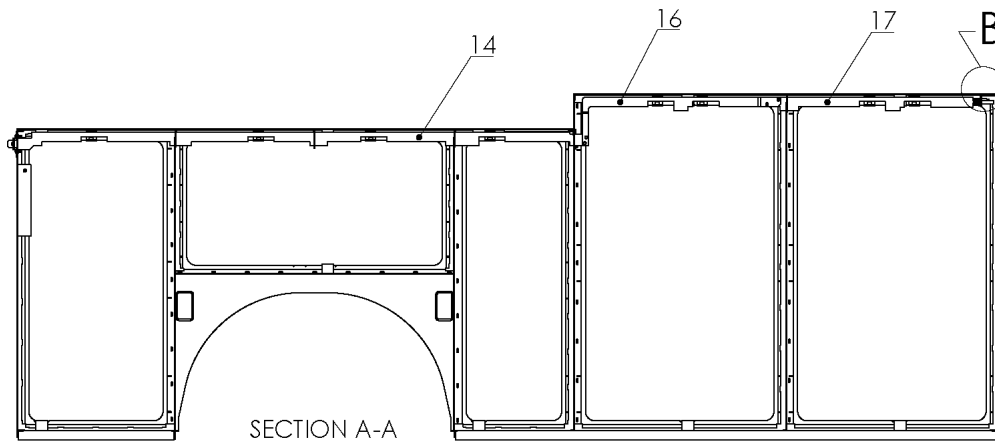
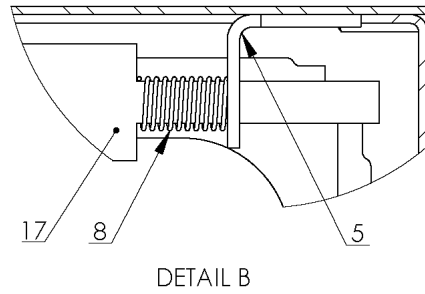
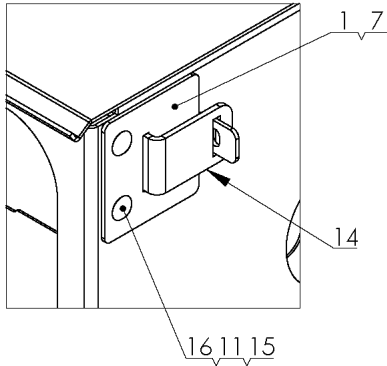

# MASTER LOCK SYSTEM TITAN SERIES 120CA - P/N: 760551000

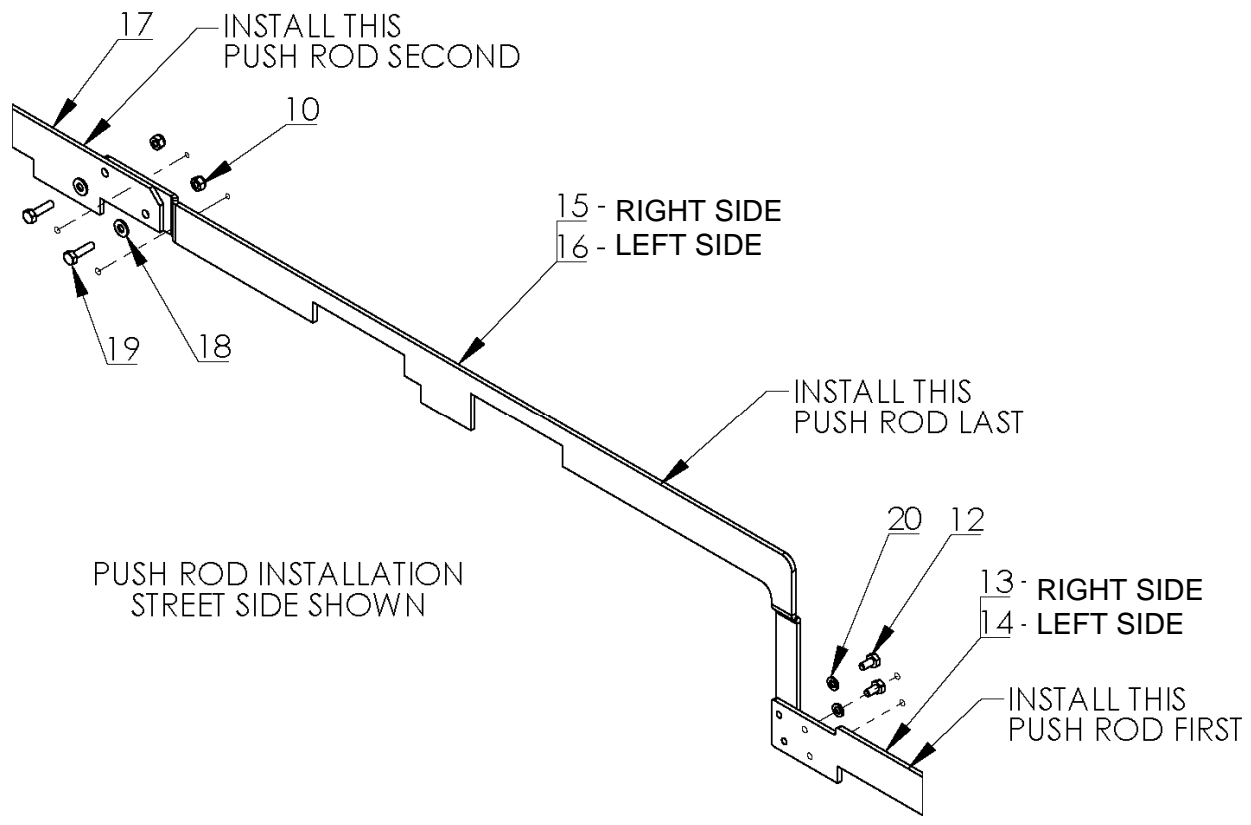

# MASTER LOCK SYSTEM TITAN SERIES

ITEM NO.	120CA	84CA	PART NUMBER	DESCRIPTION
1	2	2	560121001	MASTER LOCK LOCKING PLATE
2	0	1	560404000	PUSH BAR RS
3	0	1	560404002	PUSH BAR LS
4	4	4	330372000	NUT HX 3/8-16UNC
5	2	2	560122000	MASTER LOCK MOUNT
6	4	4	560138000	SCREW CARRIAGE 3/8-16UNC X 1 LG
7	2	2	560139000	GASKET MASTERLOCK
8	2	2	736730000	SPRING
9	0	2	540100000	SCREW HX HD 1/4-20UNC X 5/8 LG CP
10	4	2	016300000	NUT HX NYLK 1/4-20UNC
11	4	4	021100000	WASHER SP LK 3/8
12	4	0	005406000	SCREW HX HD 1/4-28UNF X 1/2 LG
13	1	0	760560000	PUSH BAR SHORT CS, TITAN 60/120CA
14	1	0	760560002	PUSH BAR SHORT SS, TITAN 60/120CA
15	1	0	760561000	PUSH BAR FRONT CS, TITAN 60/120CA
16	1	0	760561002	PUSH BAR FRONT SS, TITAN 60/120CA
17	2	0	760562000	PUSH BAR FRONT FWD, TITAN 60/120CA
18	4	0	020300000	WASHER FL 1/4
19	4	0	005604000	SCREW HX HD 1/4-20UNC X 1 LG
20	4	0	020200000	WASHER SP LK 1/4

# SHELF LOCATION TITAN SERIES 84CA 560535-XXX

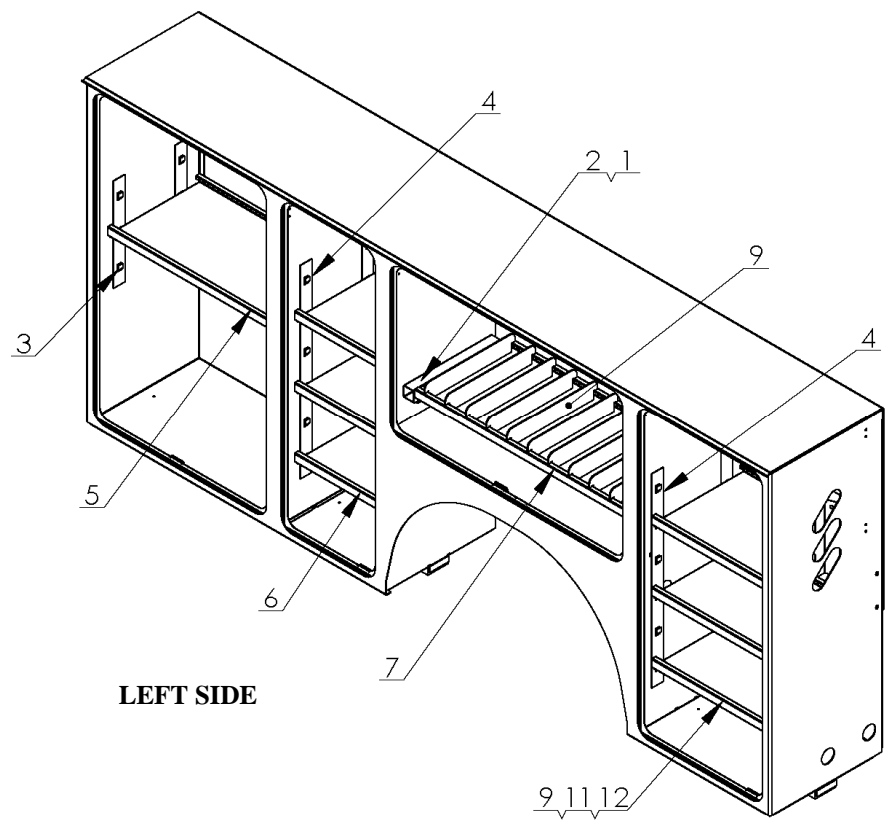

**LEFT SIDE**

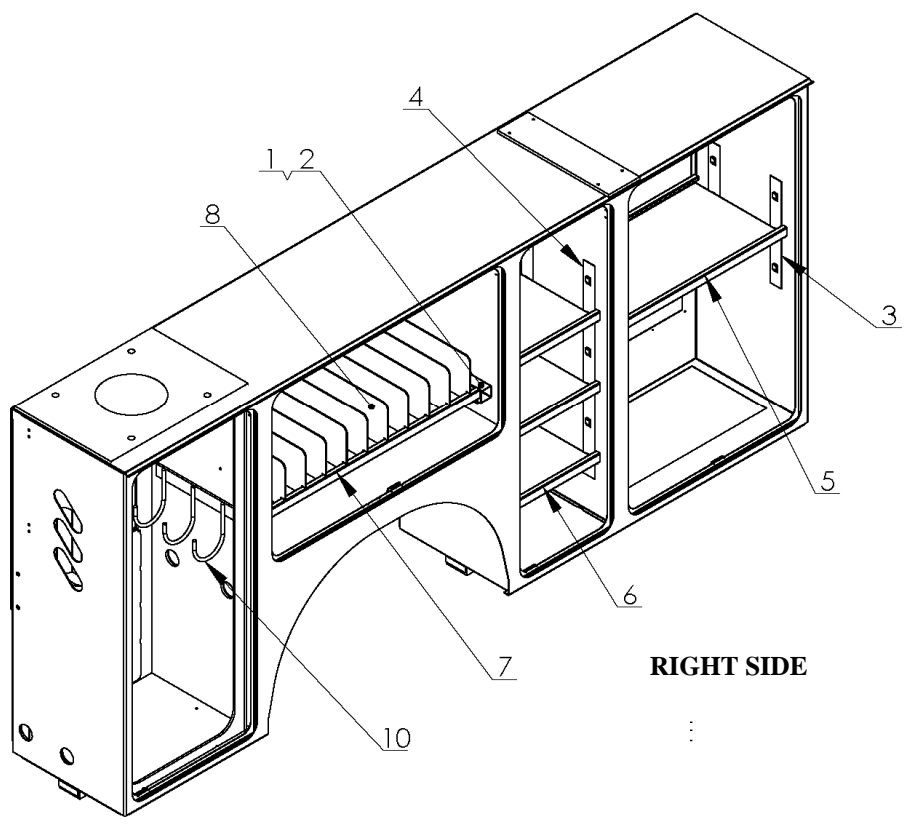

**RIGHT SIDE**

# **SHELF LOCATION**

## **TITAN SERIES 84CA 560535-XXX**

			000	001	002	003	004	005	006	007	008
ITEM	PART NO.	DESCRIPTION	QTY	QTY	QTY	QTY	QTY	QTY	QTY	QTY	QTY
1	750804000	BRACKET SHELF	4			2	2			2	
2	340196000	TBG SQ 2 X .083W X 17	4			2	2				
3	750798000	SHELF STRIP SUPPORT 18"	8	4							
4	750799000	SHELF STRIP SUPPORT 36"	12		4				4		4
5	560476000	SHELF FRONT COMP	2	1							
6	560477000	SHELF MID COMP	6		3						1
7	560536000	SHELF HORIZ (PLASTIC DIVIDERS)	2			1	1				
8	560481001	DIVIDER, SHELF TALL (PLASTIC)	11			11					
9	560480001	DIVIDER, SHELF SHORT (PLASTIC)	14				11		3		
10	750807000	CHAIN HOOK ASSEMBLY	1					1			
11	560537002	SHELF REAR COMP (PLASTIC DIVIDERS)	3						3		
12	760236000	SHELF CRANE COMP								1	

**NOTES:**

- 000 EQUALS ALL PARTS FOR TOTAL SHELF PACKAGE
- 001 EQUALS ONLY SHELVING FRONT COMP. RIGHT OR LEFT
- 002 EQUALS ONLY SHELVING MID COMP. RIGHT OR LEFT
- 003 EQUALS ONLY SHELVING HORIZ. COMP. W / TALL DIVIDERS
- 004 EQUALS ONLY SHELVING HORIZ. COMP. W / SHORT DIVIDERS
- 005 EQUALS ONLY CHAIN HOOK/REAR COMP. (CRANE BOX)
- 006 EQUALS ONLY SHELVING/REAR COMP. (OPPOSITE CRN BOX)
- 007 EQUALS ONLY SHELVING/REAR CRANE COMPT
- 008 EQUALS ONLY SHELVING MID COMP. RIGHT OR LEFT (1 SHELF ONLY)

# SHELF LOCATION TITAN SERIES 120CA 760537-XXX

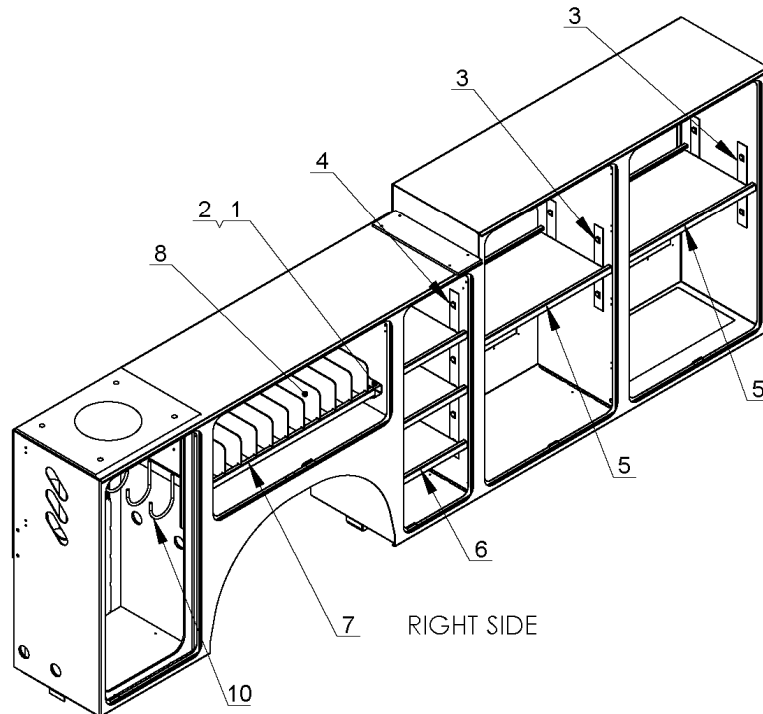
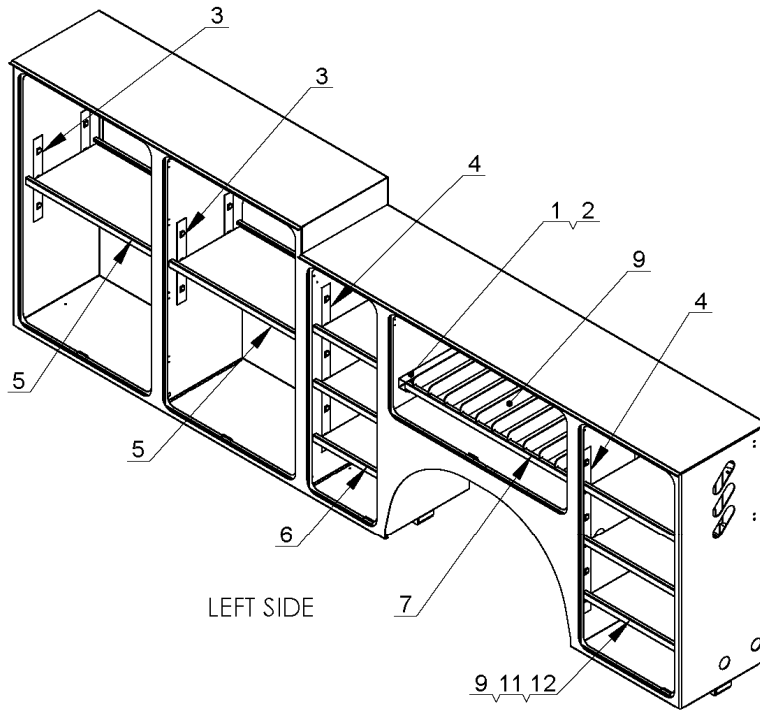

# **SHELF LOCATION TITAN SERIES 120CA 760537XXX**

SHELF LOCATION CHART			- 000	- 001
ITEM	PART NO.	DESCRIPTION	QTY	QTY
1	750804000	BRACKET SHELF	4	4
2	340196000	TBG SQ 2 X .083W X 17	4	4
3	750798000	SHELF STRIP SUPPORT 18"	16	16
4	750799000	SHELF STRIP SUPPORT 36"	12	16
5	560476000	SHELF FRONT COMP	4	4
6	760538000	SHELF MID COMP	6	9
7	560536000	SHELF HORIZ (PLASTIC DIVIDERS)	2	2
8	560481001	DIVIDER, SHELF TALL (PLASTIC)	11	11
9	560480001	DIVIDER, SHELF SHORT (PLASTIC)	14	14
10	750807000	CHAIN HOOK ASSEMBLY	1	1
11	560227000	TBG SQ STL 2 1/2 X .120W X 36	2	2
12	560537000	SHELF REAR COMP (PLASTIC DIVIDERS)	3	3

# SLIDE OUT TRAY TITAN SERIES - P/N:560238002

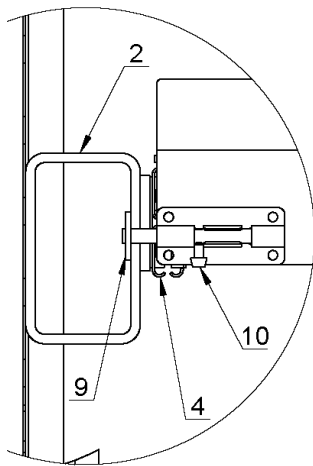
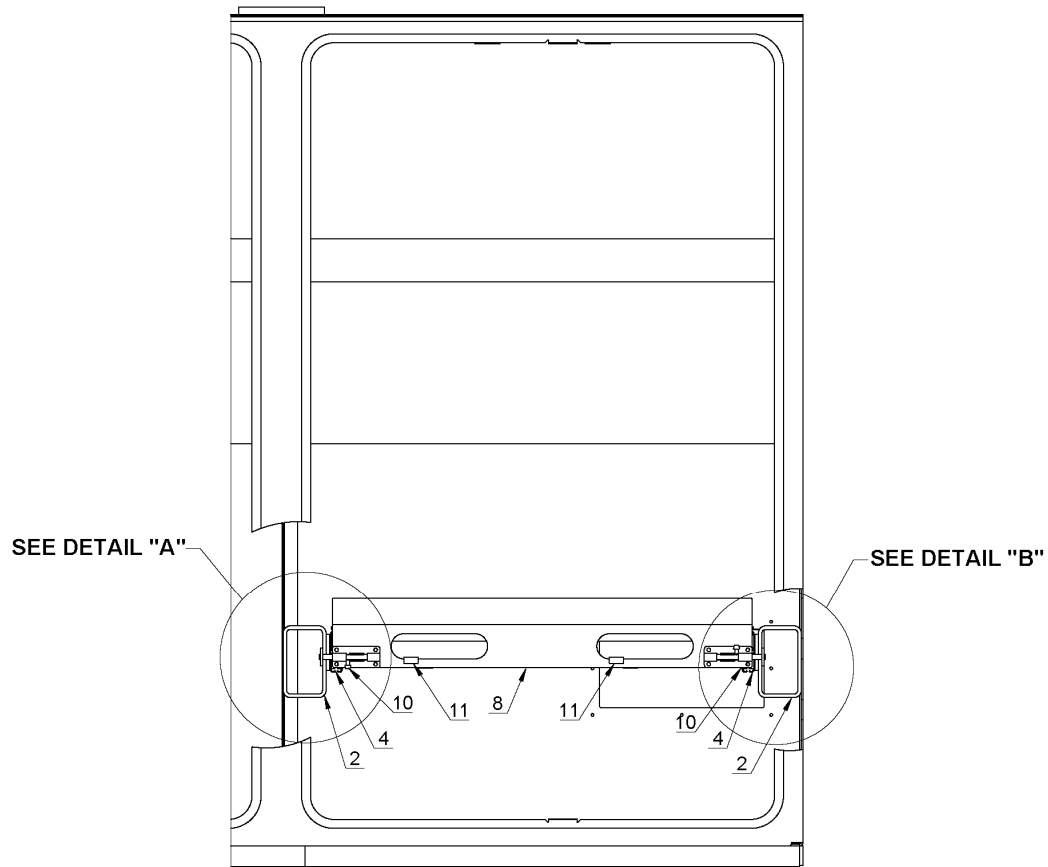

**DETAIL A**

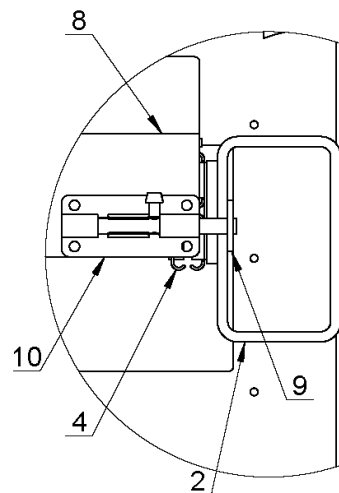

**DETAIL B**



**SLIDE OUT TRAY  
TITAN SERIES - P/N:560238002**

TITAN LEFT/RIGHT SIDE FRONT COMPARTMENT ONLY

<b>ITEM NO.</b>	<b>QTY</b>	<b>PART NUMBER</b>	<b>DESCRIPTION</b>
1	2	340040003	BRACE, SLIDE OUT TRAY
2	2	560577000	TUBE, SUPPORT SLIDE OUT TRAY
3	2	340415000	SHIM, TRAY SUPPORT
4	2	754551000	SLIDE SET 18/550#
5	28	330675000	NUT, KEPS #8-32UNC
6	56	753275000	SCREW SOC BUT HD #8-32UNC X 5/8 LG GR8
7	2	754554000	SUPPORT SHELF
8	1	560241003	SHELF, SLIDE OUT TRAY
9	2	750747001	BARREL BOLT RETAINER
10	2	750742000	BARREL BOLT
11	4	715048000	EDGE TRIM 3/32

# TOOL BOX TITAN 50/60/70

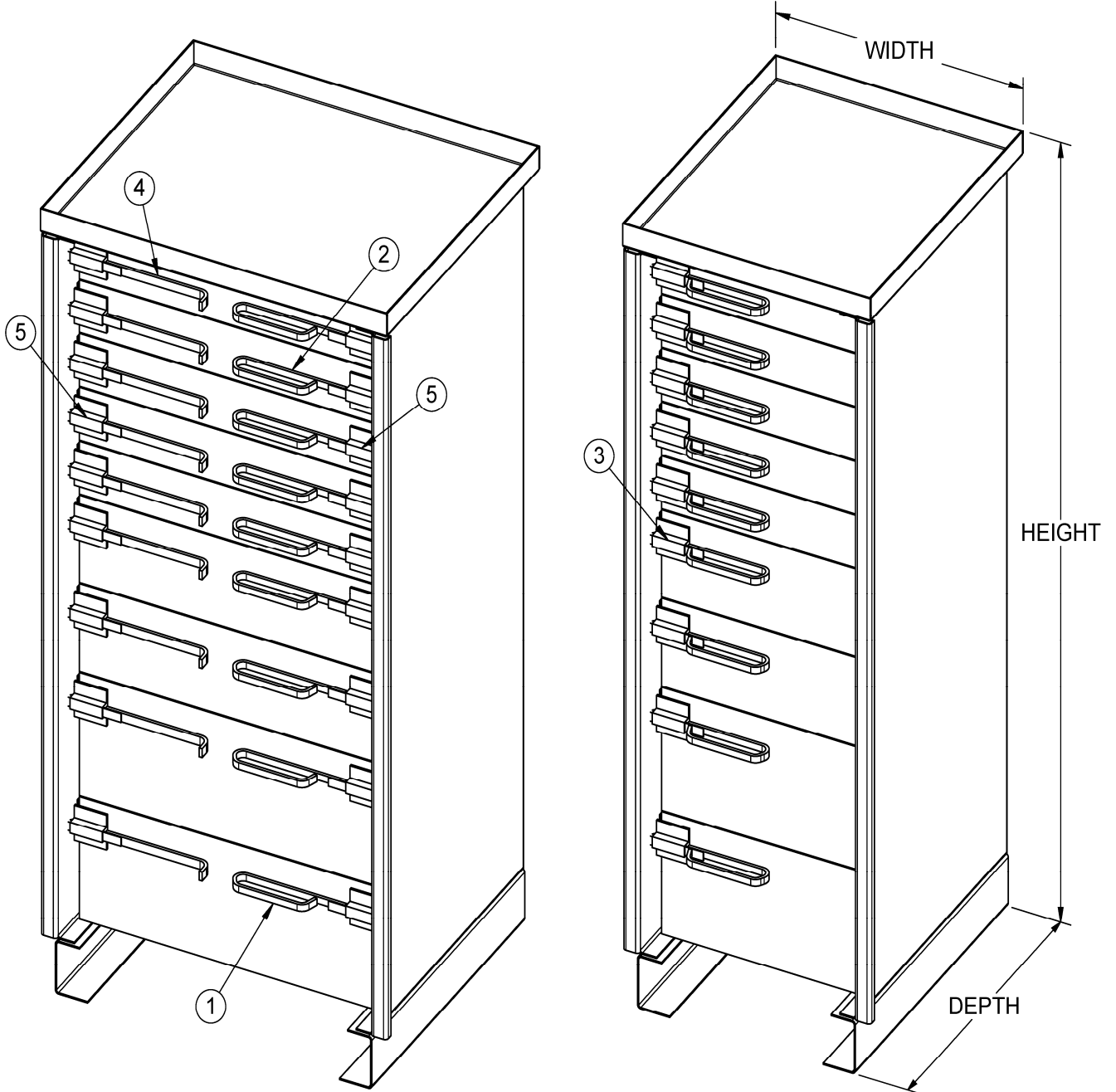

(MORE THAN 20" WIDE)

(20" WIDE OR LESS)

# TOOL BOX TITAN 50/60/70

TOOLBOX PART NUMBERS		
COMPARTMENT	PART NO.	DESCRIPTION
FRONT	560127000	TOOLBOX, (2) 7", (2) 5", (5) 3", 30W x 44.25H x 18D, FRONT, T38(TALL)/50/60/70
MID	560126000	TOOLBOX, (2) 7", (2) 5", (5) 3", 15.5W x 44.25H x 18D, MID, T50/60/70
HORIZONTAL	560124000	TOOLBOX, (1) 5", (3) 3", 41W x 19.25H x 18D, HORIZ, T50/60/70
REAR	560125000	TOOLBOX, (2) 7", (2) 5", (5) 3", 21.5W x 44.25H x 18D, REAR, T50/60/70

TOOLBOX SERVICE PART NUMBERS		
ITEM	PART NO.	DESCRIPTION
1	560330000	BRUSHED HANDL W/O LOGO
2	560330001	8" BAR FOR HANDLE, TOOLBOX (24"W)
	560330006	11" BAR FOR HANDLE, TOOLBOX (30"W)
	560330009	16 1/2" BAR FOR HANDLE, TOOLBOX (41"W)
3	560332000	LATCH, TOOLBOX (14" WIDE UNIT WIDTH)
	560332010	LATCH, TOOLBOX (15-1/2" WIDE UNIT WIDTH)
	560332011	LATCH, TOOLBOX (16" WIDE UNIT WIDTH)
	560322012	LATCH, TOOLBOX (20" WIDE UNIT WIDTH)
4	560332001	5 7/8" THUMB RELEASE BAR, W/O HANDLE, TOOLBOX (21.5"W)
	560332006	10 1/8" THUMB RELEASE BAR, W/O HANDLE, TOOLBOX (30"W)
	560332009	15 5/8" THUMB RELEASE BAR, W/O HANDLE, TOOLBOX (41"W)
5	560331000	LATCH BOLT
*	560333000	HEAVY DUTY DRAWER SLIDES 16"
*	560336000	DIVIDER TOOLBOX 7"HIGH X 16"DEEP
*	560335000	DIVIDER TOOLBOX 5"HIGH X 16"DEEP
*	560334000	DIVIDER, 3" HIGH X 16" DEEP
*		NOT SHOWN

# OXY/ACET ASSY TITAN SERIES - P/N: 736230000

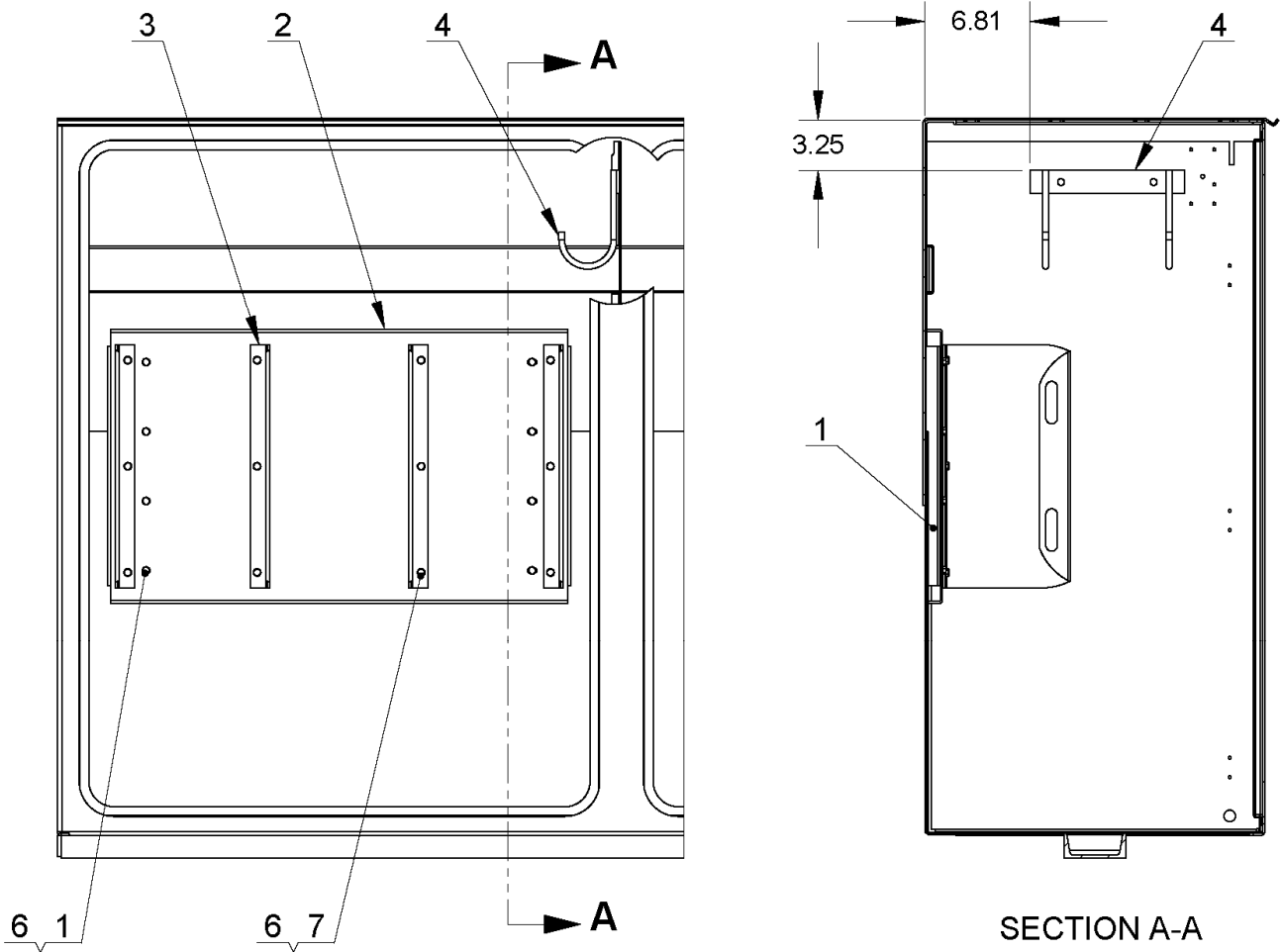

ITEM NO.	QTY.	PART NO.	DESCRIPTION
1	2	738766000	MOUNTING CHANNEL ASSY
2	1	736226000	OXY-ACET MTG PLT ASSY
3	4	736229000	DIVIDER PNL - OXY/ACET
4	1	750613000	HOSE HOOK WDMT
5	1	725039000	STRAP HOLD DOWN OXY/ACET
6	20	020200000	WASHER SP LK 1/4
7	20	005500000	SCREW HX HD 1/4-20UNC X 3/4 LG

# OXY DIVIDER/SHELVING PACKAGE TITAN SERIES - P/N: 560483000

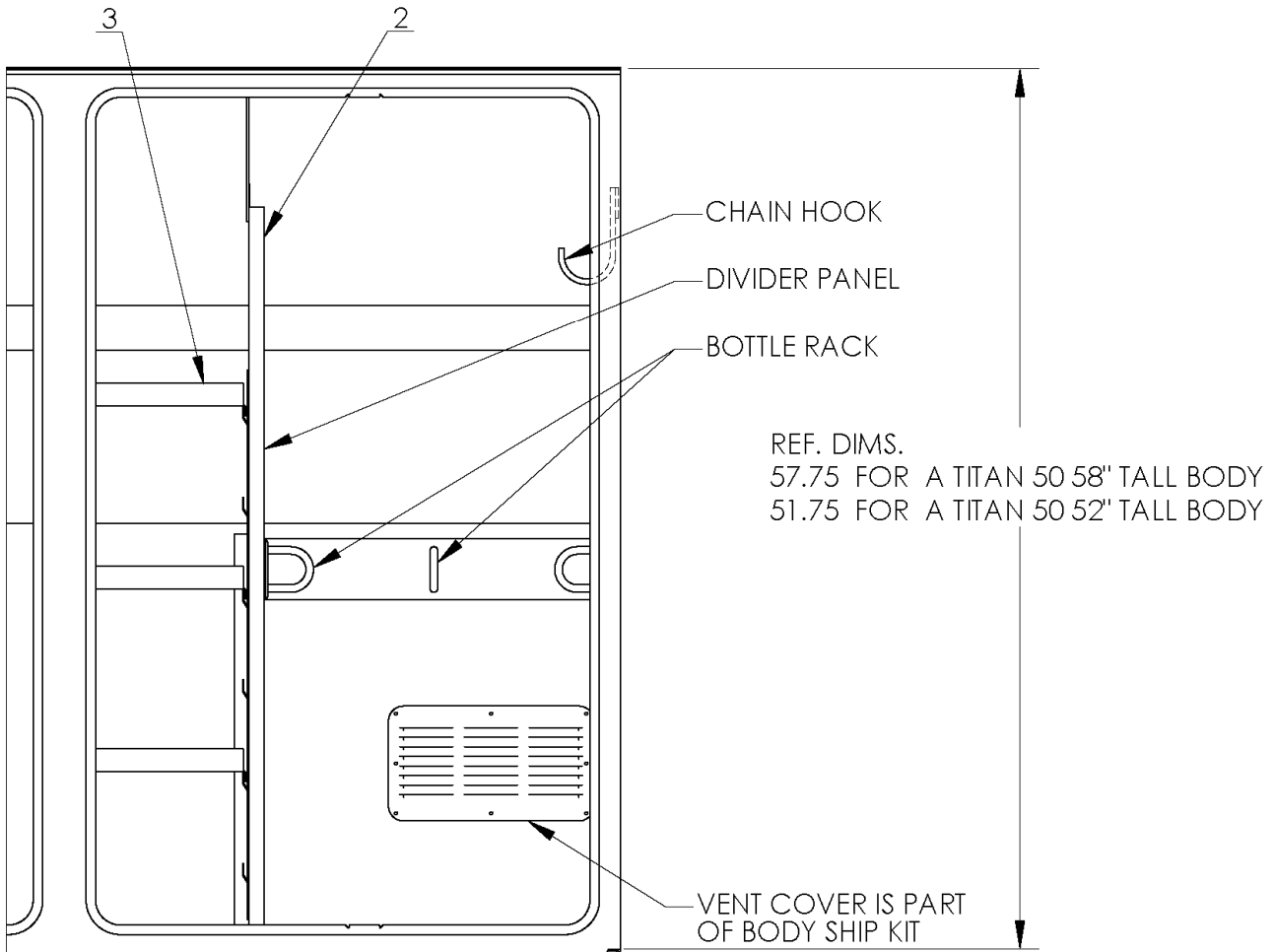

ITEM NO.	QTY.	PART NO.	DESCRIPTION
1	1	725039000	STRAP HOLD DOWN OXY/ACET
2	1	560400000	OXY DIVIDER/SHELVING WELDMENT
3	3	560484000	SHELF FRONT COMP (OXY/DIVIDER)

# DROP WELL TITAN SERIES

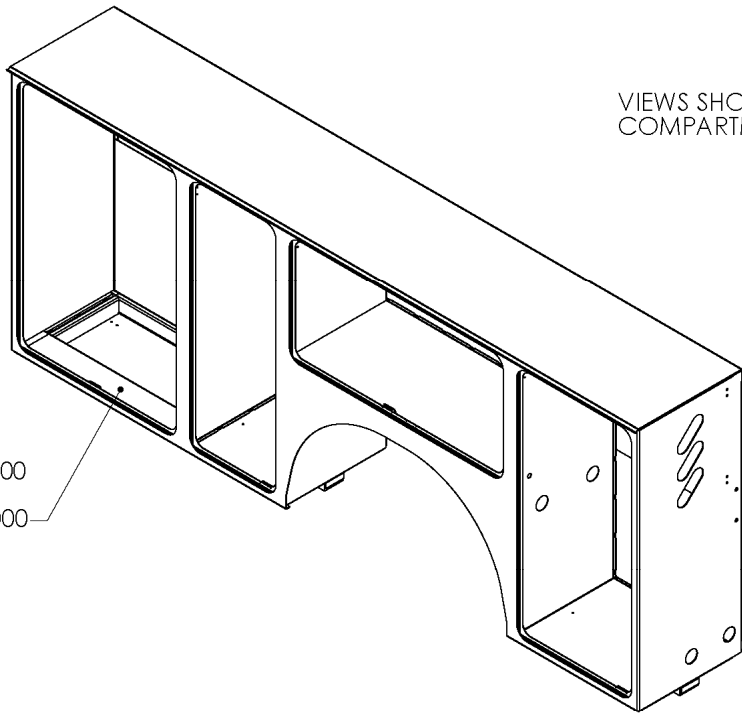

VIEWS SHOWS DROP WELL IN THE FRONT COMPARTMENT

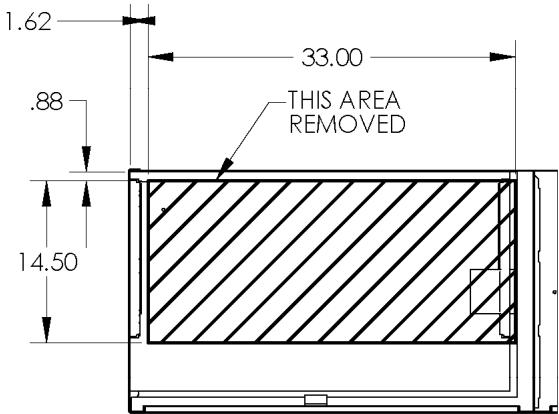

FRONT COMP MODIFICATION  
CUTOUT DETAIL FOR DROP BOX

2" DROP WELL

6" DROP WELL

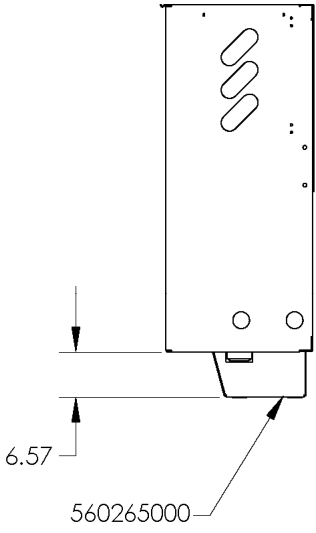
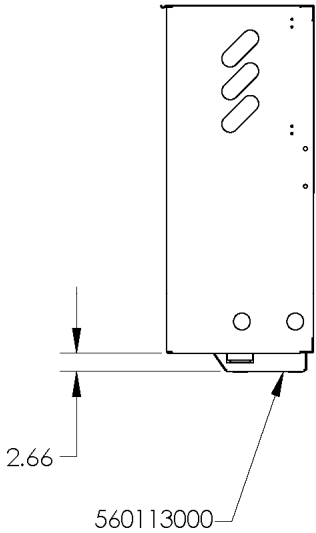

# PARTS WASHER TITAN SERIES

PART NO.	A	B	C	D	E	F	G
560600000	19 3/4	16	11 3/8	18	20 3/8	15 7/8	16 7/8
560601000	18	16	8 15/16	14	16 3/8	12	-

- ELECTRONIC 12V DC PUMP w/ 7-9 PSI 45 GPH DELIVERY CAPACITY.
- TRIM-LOK 4100B3X1/8C TANK LID WEATHERSTRIP
- 20 MESH SUCTION STRAINER
- 10 MICRON SPIN ON FILTER ELEMENT
- WEATHERPAK 2 PRONG SEALED
- ELECTRICAL SWITCH CONNECTOR
- WIRE LEAD INCLUDES TOGGLE AND PILOT LIGHT w/BRACKET

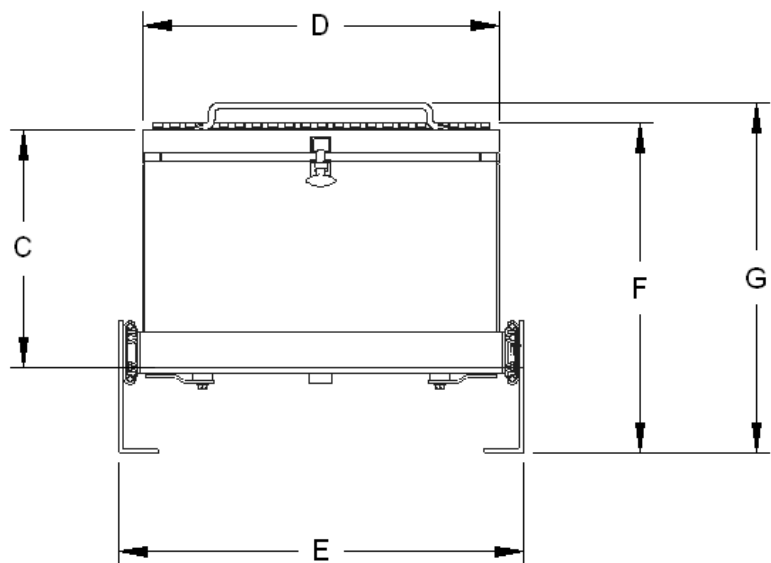
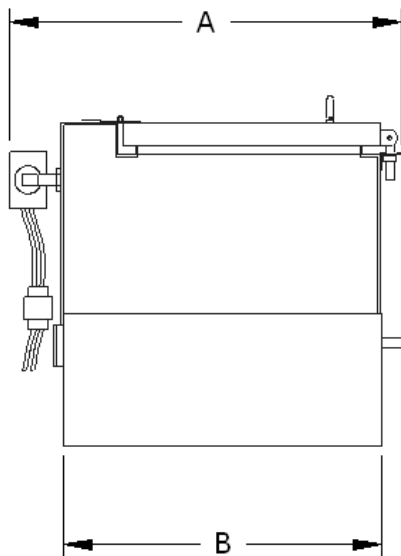
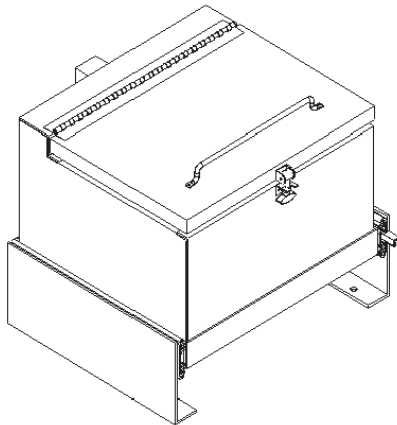

# ROPE LIGHT KIT

## TITAN SERIES - P/N: 560271-XXX

3.36 WATTS PER FOOT  
 LAMPS SPACED EVERY 1"  
 BULB LIFE: 25,000 HOURS  
 TEMP RATING: +140 TO -40 DEGRESS F  
 LUMINOUS INTENSITY: 350 L

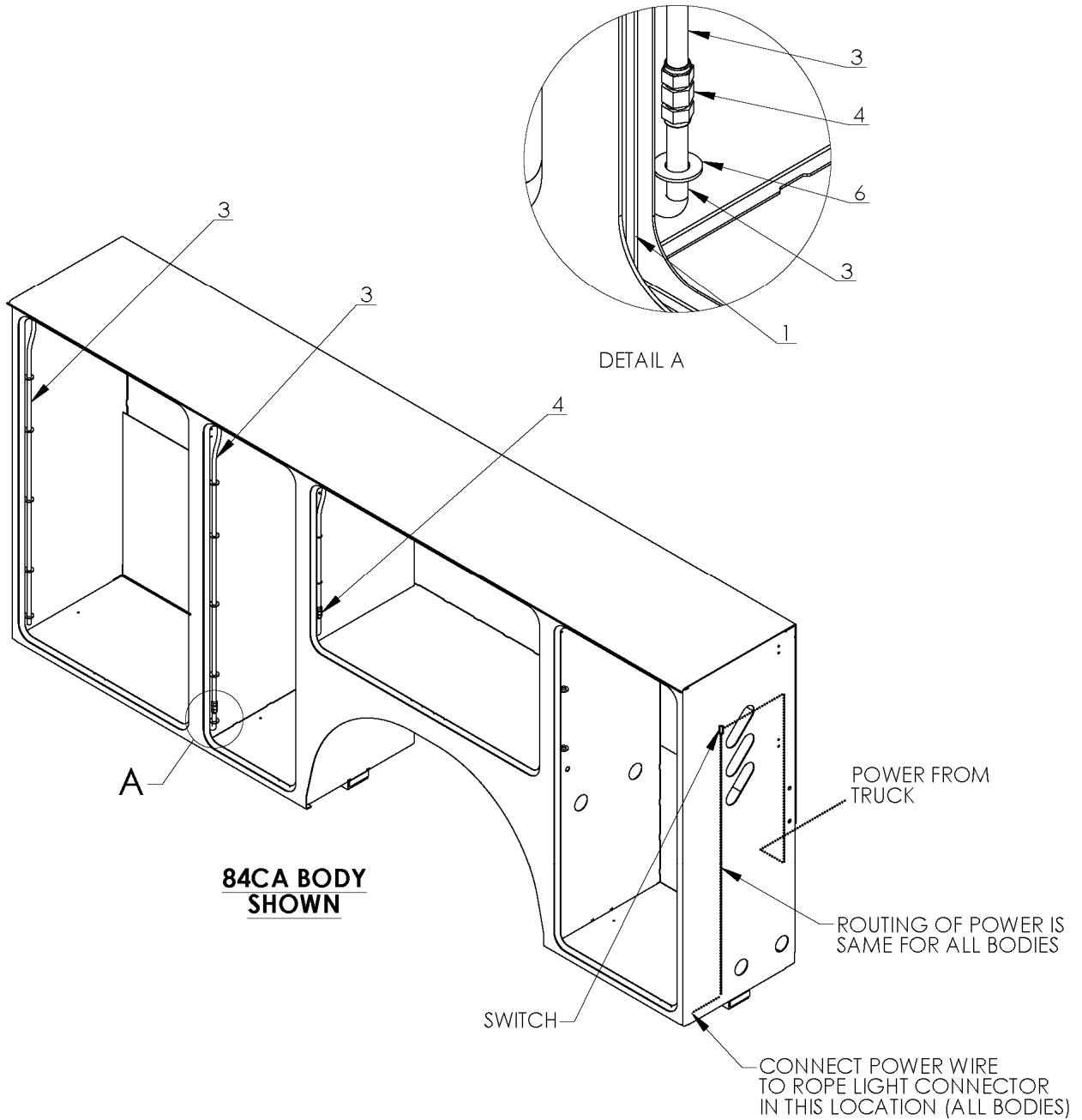



**ROPE LIGHT KIT**  
**TITAN SERIES - P/N: 560271-XXX**

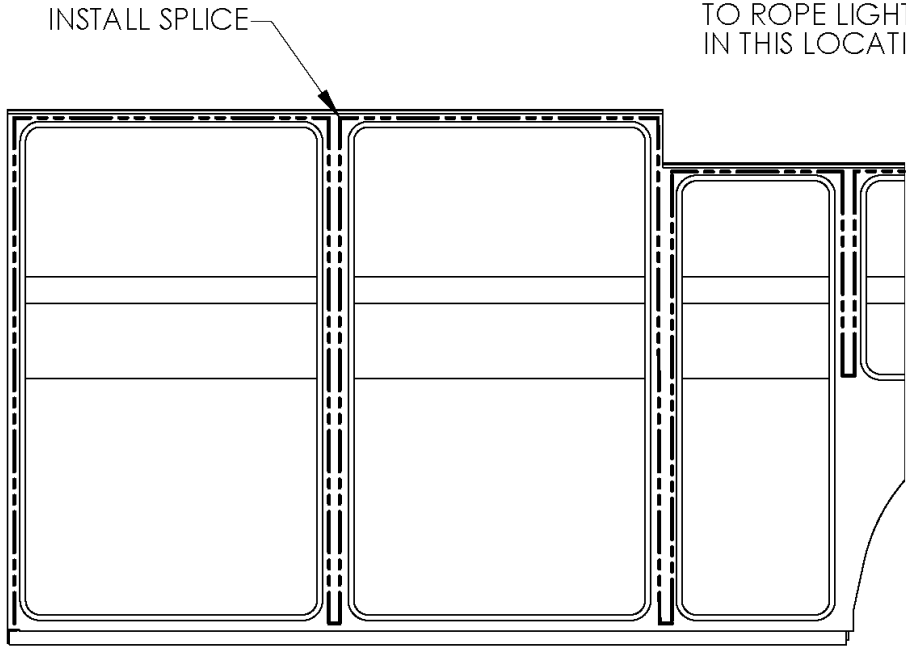
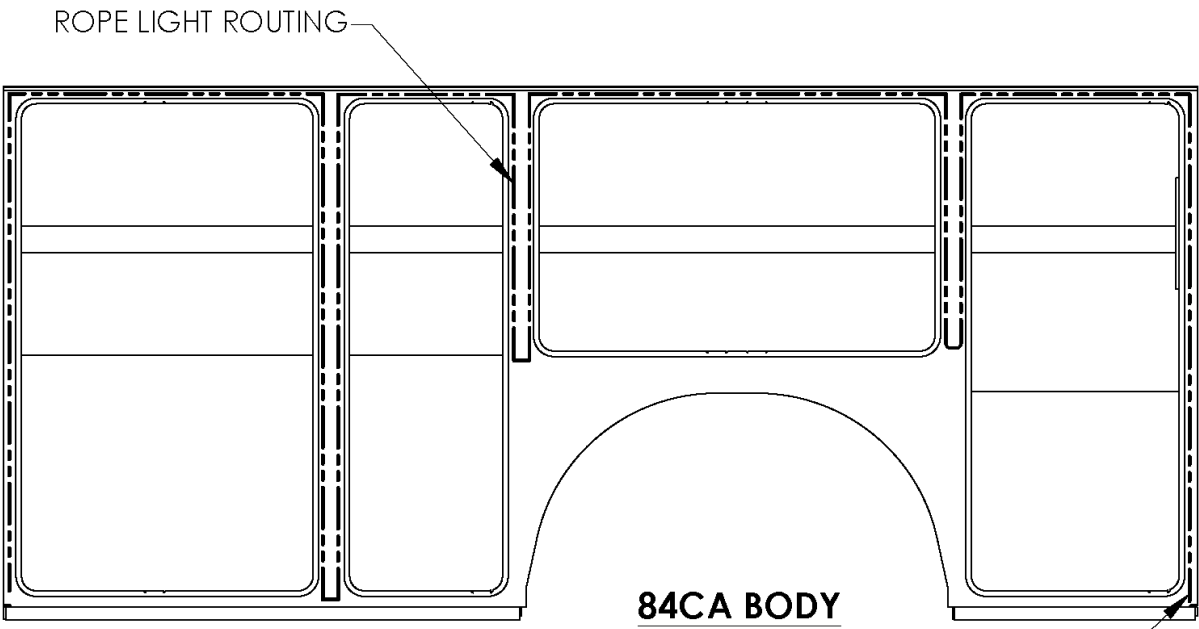

**120CA BODY**  
ROUTING FOR HORIZ. & REAR COMPARTMENTS  
ARE THE SAME AS OTHER BODIES

# ROPE LIGHT KIT

## TITAN SERIES - P/N: 560271-XXX

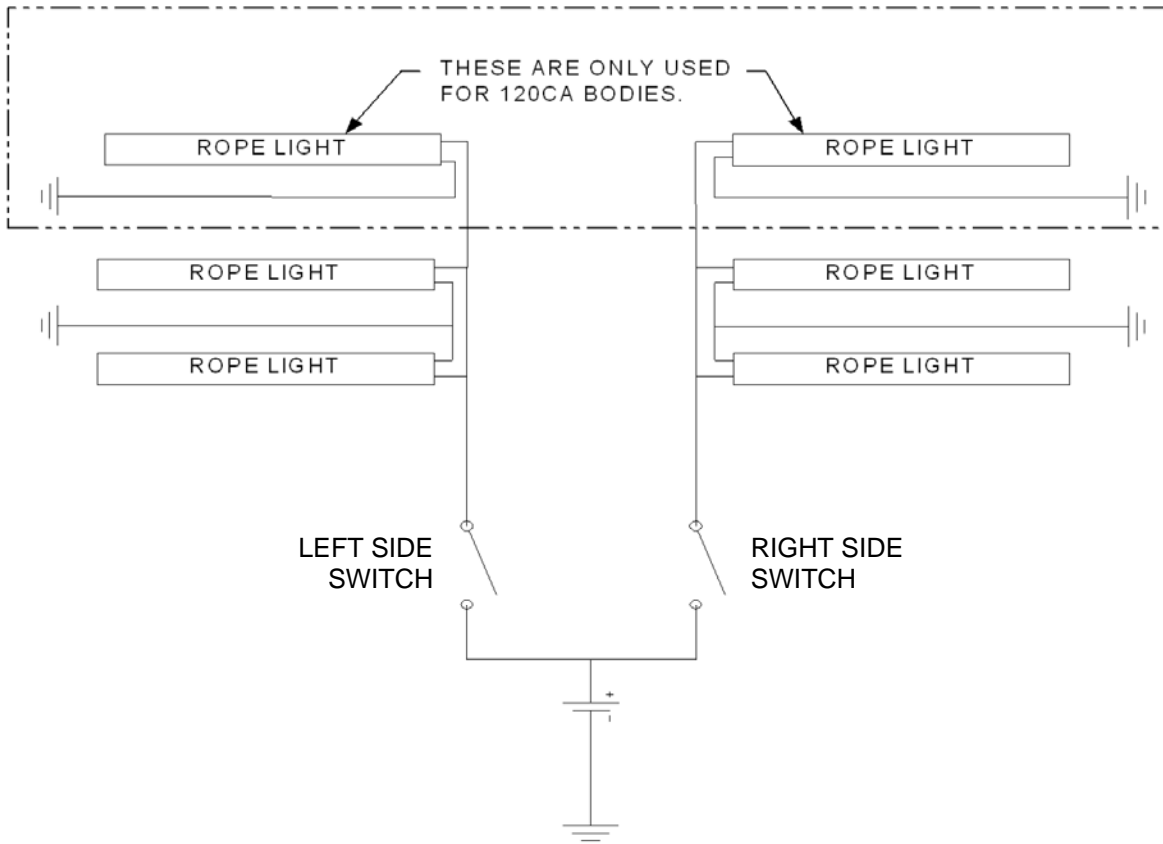

COMPARTMENT LIGHT KIT CHART			-000 (84 CA)	-010 (120 CA)
ITEM NO.	DESCRIPTION PART,NO.	PART NO.	QTY.	QTY.
1	GROMMET, RUBBER	750169000	6	6
2	SWITCH TOGGLE (ON-OFF)	750739000	2	2
3	LIGHTING, ROPE	560116000	3	5
4	SPLICE, 1/2" ROPE LIGHT	560388000	2	4

# COMPARTMENT LIGHT KIT TITAN SERIES - P/N: 560271-XXX

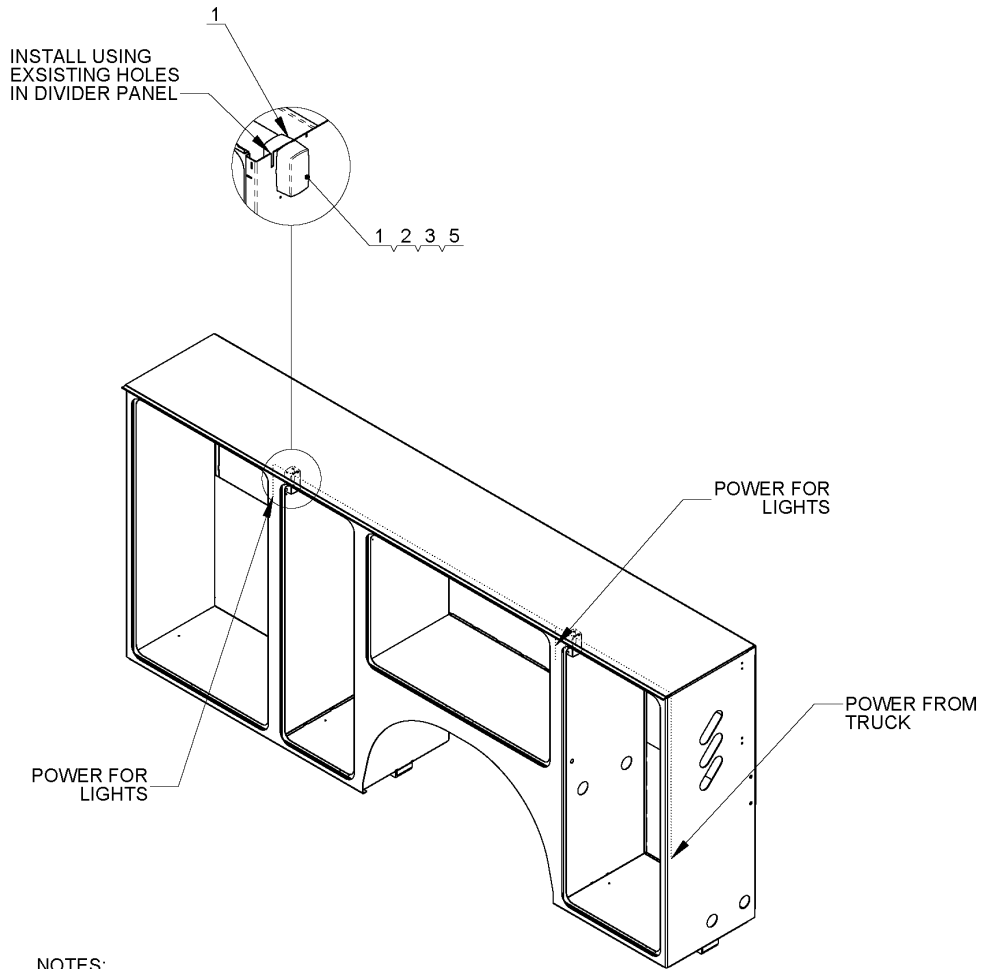

- NOTES:
1. MOUNTING FOR 84 CA IS SHOWN. MOUNTING FOR 120CA AND 60 CA ARE SIMILAR. SEE NEXT SHEET FOR WIRING DIAGRAM.
  2. LEFT SIDE ROUTING SHOWN. RIGHT SIDE OPPOSITE.

COMPARTMENT LIGHT KIT CHART			-001 - 84 CA	-011 - 120 CA
ITEM #	DESCRIPTION	PART. NO.	QTY.	QTY.
1	LIGHT, COMPARTMENT	750730000	8	10
2	WASHER FL #8 ZP	019701000	16	20
3	SCREW RD HD #8-32UNC X 3/4LG	001503000	16	20
4	WASHER SP LK #8	019700000	16	20
5	NUT HX. #8-32UNC CP	015500000	16	20

# **COMPARTMENT LIGHT KIT TITAN SERIES - P/N: 560271-XXX**

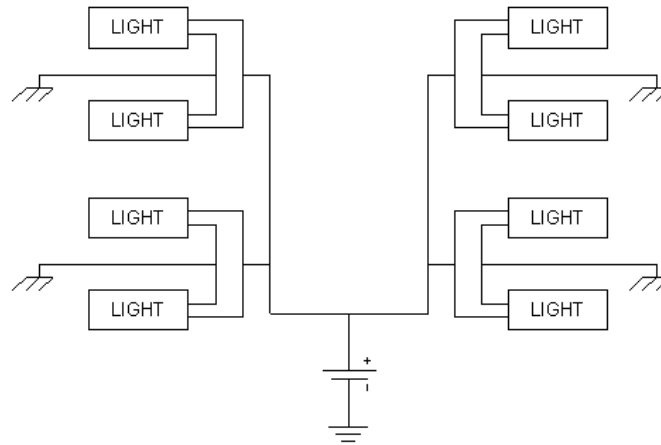

## **560271001 - 84 CA**

THE COMPARTMENT LIGHTS ARE MOUNTED BACK TO BACK ON THE DIVIDER PANEL BETWEEN THE FRONT AND MID COMPARTMENT AS WELL AS THE HORIZONTAL AND REAR COMPARTMENTS.

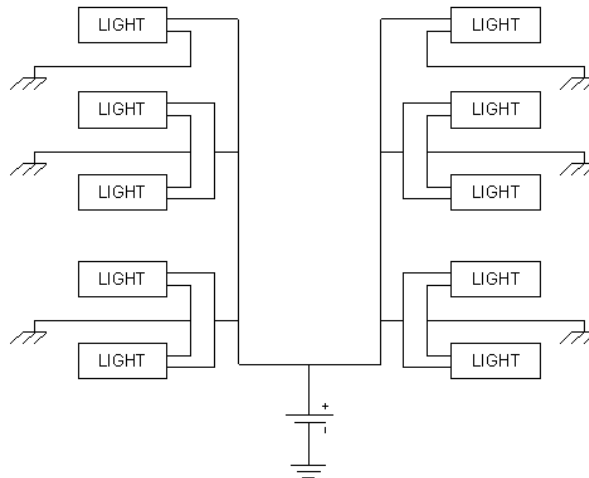

## **560271011 - 120 CA**

THE COMPARTMENT LIGHTS ARE MOUNTED BACK TO BACK ON THE DIVIDER PANEL BETWEEN THE FRONT AND MID COMPARTMENT AS WELL AS THE HORIZONTAL AND REAR COMPARTMENTS. THE OTHER LIGHT IS MOUNTED ON THE DIVIDER PANEL BETWEEN THE TWO FRONT COMPARTMENTS FACING THE CAB.

# FLOOD LIGHT KIT

## TITAN SERIES - P/N:750825000

**SPECIFICATIONS:**

- A. 408 TRACTOR LIGHT
- B. BAKED BLACK ENAMEL FINISH ON BONDERIZED STEEL HOUSING
- C. HOLLOW MOUNTING BOLD W/ SWIVELING BRACKET.
- D. 3000 CANDLE PWR BEAM
- E. 55 WATTS
- F. 12 VOLTS
- G. 4.5 AMPS
- H. 5" DIA,  
6 1/4" HEIGHT  
2 3/4" DEPTH

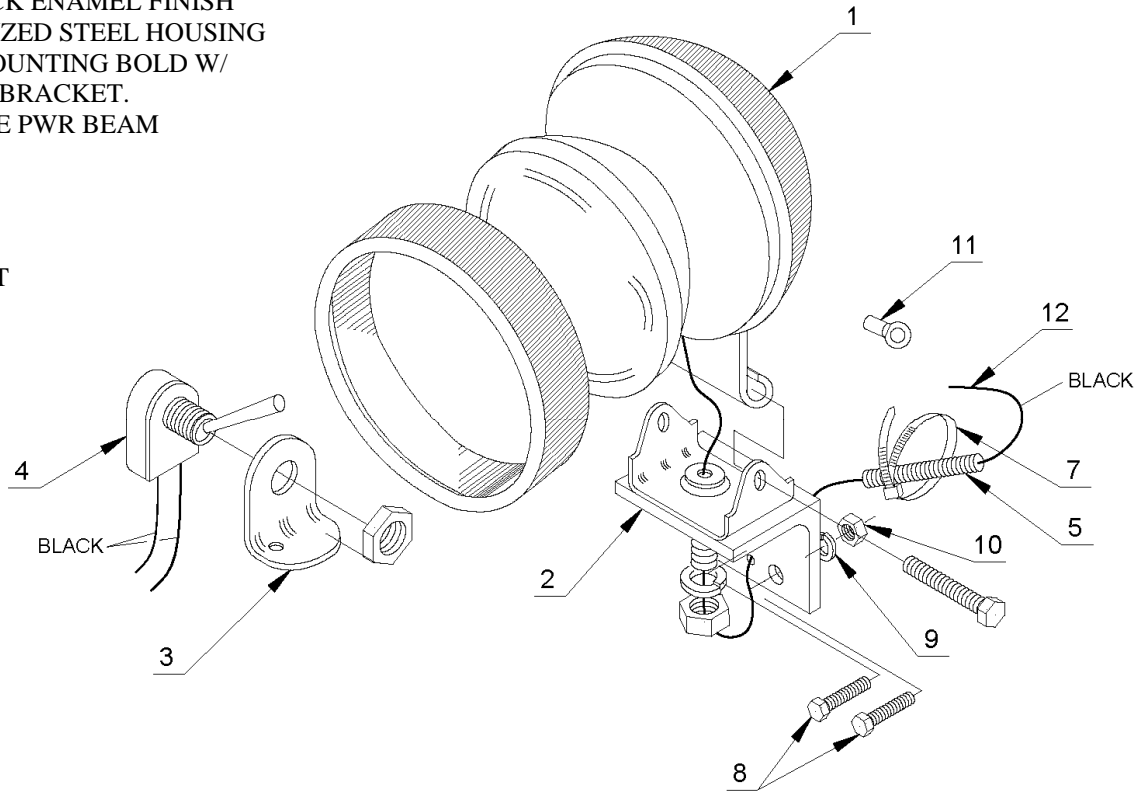

ITEM NO.	QTY	PART NUMBER	DESCRIPTION
1	1	750731000	LIGHT, FLOOD
2	1	750878000	BRKT MNTG SPOTLIGHT
3	1	750877000	BRACKET MOUNTING SWITCH
4	1	750739000	SWITCH TOGGLE(ON-OFF)
5	12 FT	750736000	LOOM CONVOLUTED
6	1	750738000	STICK-ON, CABLE TIE MOUNT
7	1	750737000	TIE, CABLE
8	2	006200000	SCREW HX HD 1/4UNC X 1 1/4 GR5
9	2	020200000	WASHER SP LK 1/4 STAINLESS
10	2	015900000	NUT HX 1/4-20UNC SS
11	2	000302000	TERMINAL WR 2R814
12	12 FT	800590000	WIRE 16G 600V 1C BLK

# FLOOD LIGHT KIT

## TITAN SERIES - P/N:750825001

### SPECIFICATIONS:

- A. HIGH BULB LIFE, 400 HR. AVERAGE
- B. EASILY REPLACEABLE BEAM
- C. FIELD TESTED UNDER EXTREME CONDITIONS.
- D. 80 DEG X 30 FLOOD
- E. TRAPEZOID
- F. SOFT
- G. 12 VOLTS
- H. 50 WATTS
- I. 4 AMPS
- J. 200,000 CANDLE PWR BEAM
- K. EASY SWIVEL MOUNT

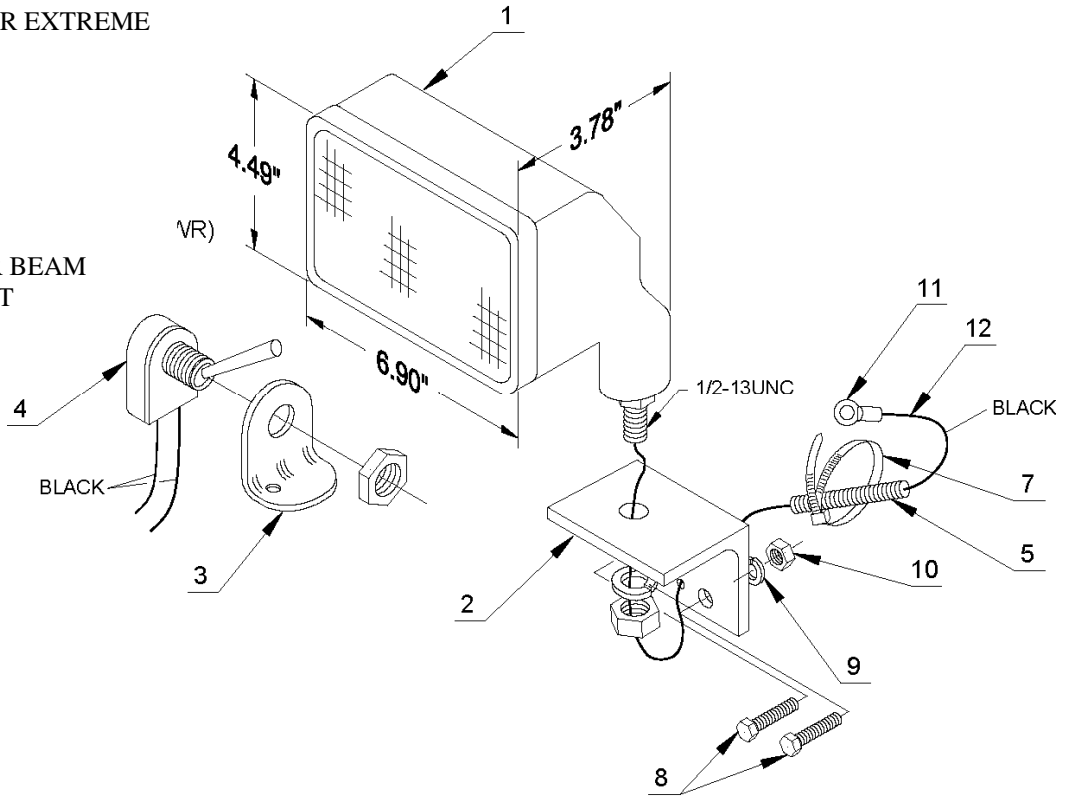

ITEM NO.	QTY	PART NUMBER	DESCRIPTION
1	1	750026000	LIGHT, SEALED BEAM
2	1	750878000	BRKT MNTG SPOTLIGHT
3	1	750877000	BRACKET MOUNTING SWITCH
4	1	750739000	SWITCH TOGGLE(ON-OFF)
5	1 2 FT	750736000	LOOM CONVOLUTED
6	1	750738000	STICK-ON, CABLE TIE MOUNT
7	1	750737000	TIE, CABLE
8	2	006200000	SCREW HX HD 1/4UNC X 1 1/4 GR5
9	2	020200000	WASHER SP LK 1/4 STAINLESS
10	2	015900000	NUT HX 1/4-20UNC SS
11	2	000302000	TERMINAL WR 2R814
12	12 FT	800590000	WIRE 16G 600V 1C BLK

# BOOM SUPPORT TITAN SERIES - P/N: 715064000

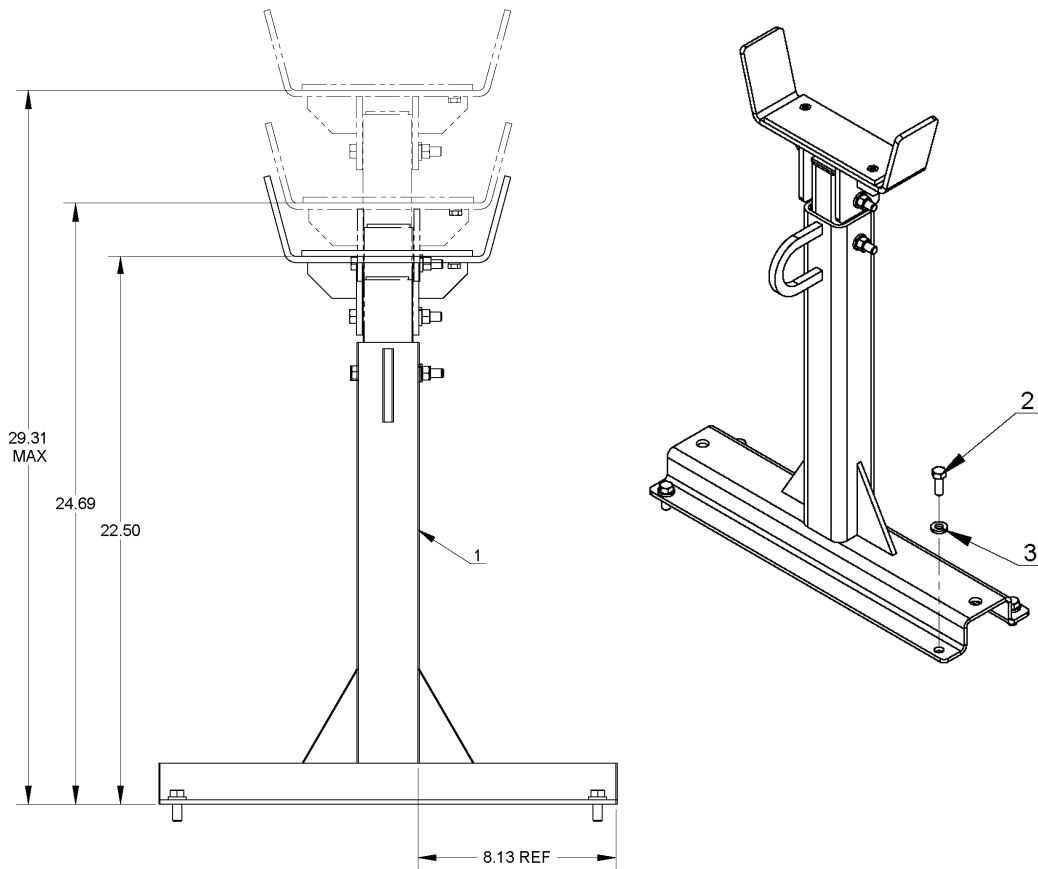
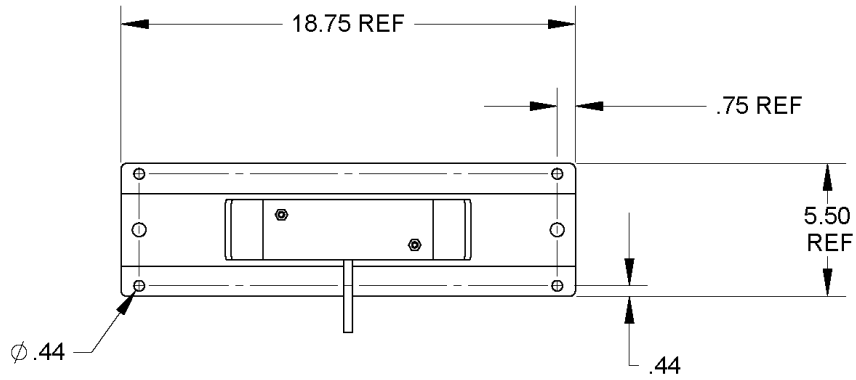

ITEM NO.	QTY.	PART NO.	DESCRIPTION
1	1	715065000	BOOM SUPPORT ASSY (TALL)
2	4	330371000	SCREW HX HD 3/8-16UNC X 1LG GR8
3	4	021100000	WASHER SP LK 3/8

# BULKHEAD RESERVOIR TITAN SERIES

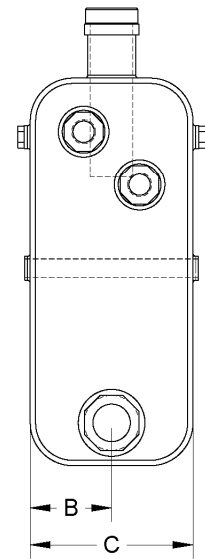
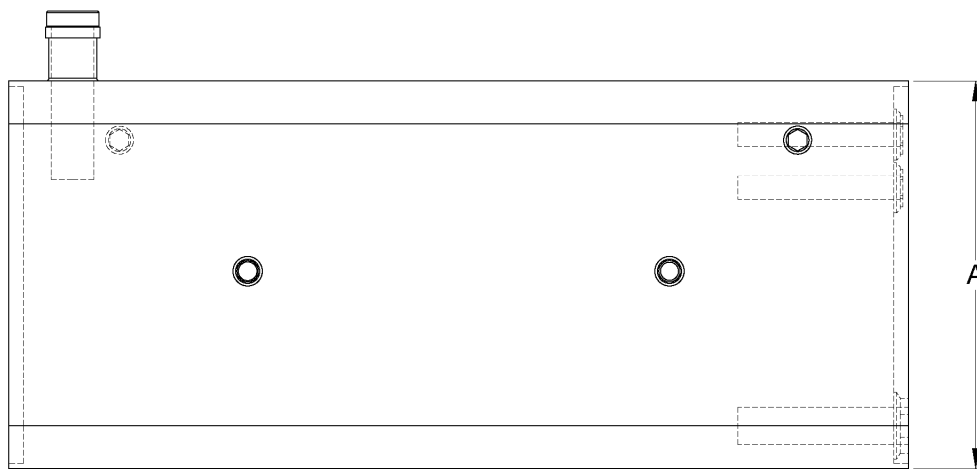
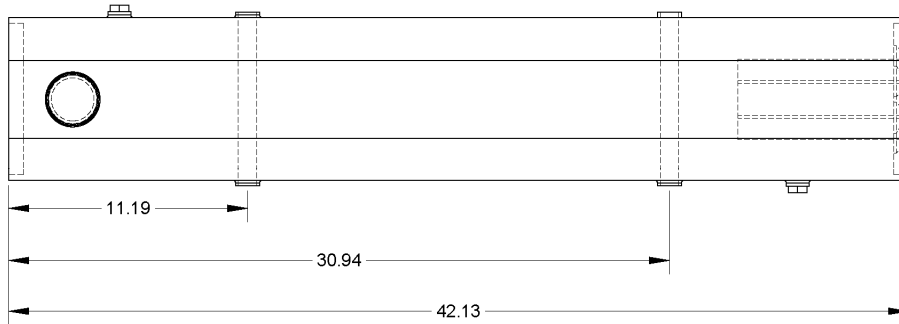

	A	B	C
738498000 (23 GALLON)	18.15	3.81	7.625
751095050 (36 GALLON)	26.06	4.03	8.06

SERVICE PARTS INCLUDE	23 GALLON	36 GALLON
<b>FILTER, RESERVOIR</b>	NA	751095051
<b>CAP, FILLER BREATHER WITH STRAINER</b>	751095055	751095055
<b>FILTER ASSEMBLY</b>	750380000	751095051
<b>REPLACEMENT FILTER</b>	NA	751095056



# AIR RECEIVER TANK TITAN SERIES

	OVERALL LENGTH	OVERALL TANK DIA.
750828000 30 GALLON TANK	36 3/4"	31 1/2"
750848000 60 GALLON TANK	46 1/2"	40"

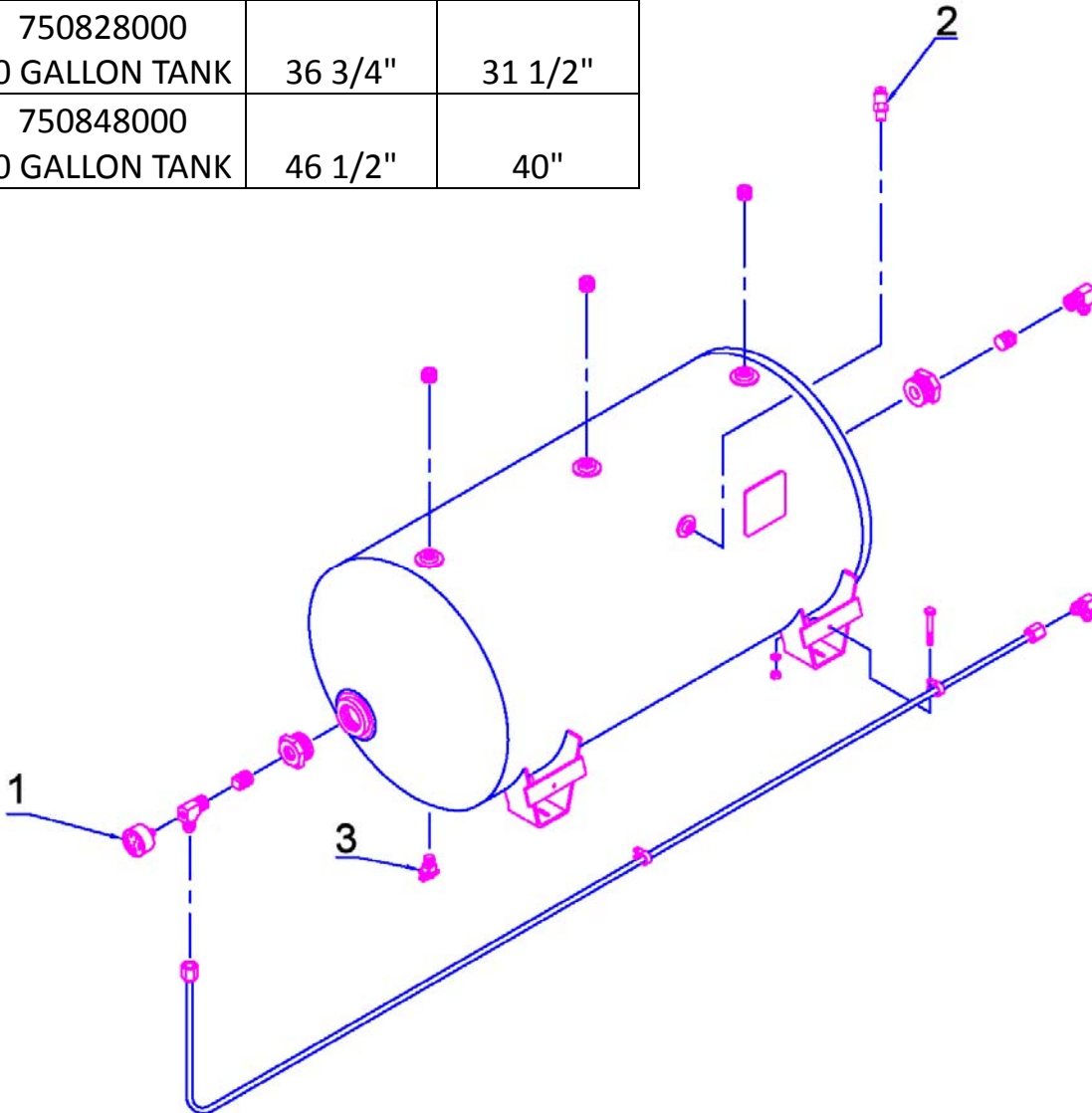

**REPLACEMENT PARTS INCLUDE:**

ITEM NO.	QTY	PART NUMBER	DESCRIPTION
1	1	750205006	GAUGE, 0-200 PSI AIR (REF.)
2	1	750715000	VALVE, BIB DRAIN
3	1	751220100	VALVE RELIEF, 200 PSI, 1/4 NPT, ALUM

# AIR RECEIVER TANK, 30 GALLON TITAN SERIES - P/N:751220000

**NOTE:**

1. THIS RECEIVER TANK IS TO BE MOUNTED UNDER TRUCK CHASSIS.
2. CANNOT BE USED WITH AFT FUEL TANKS.

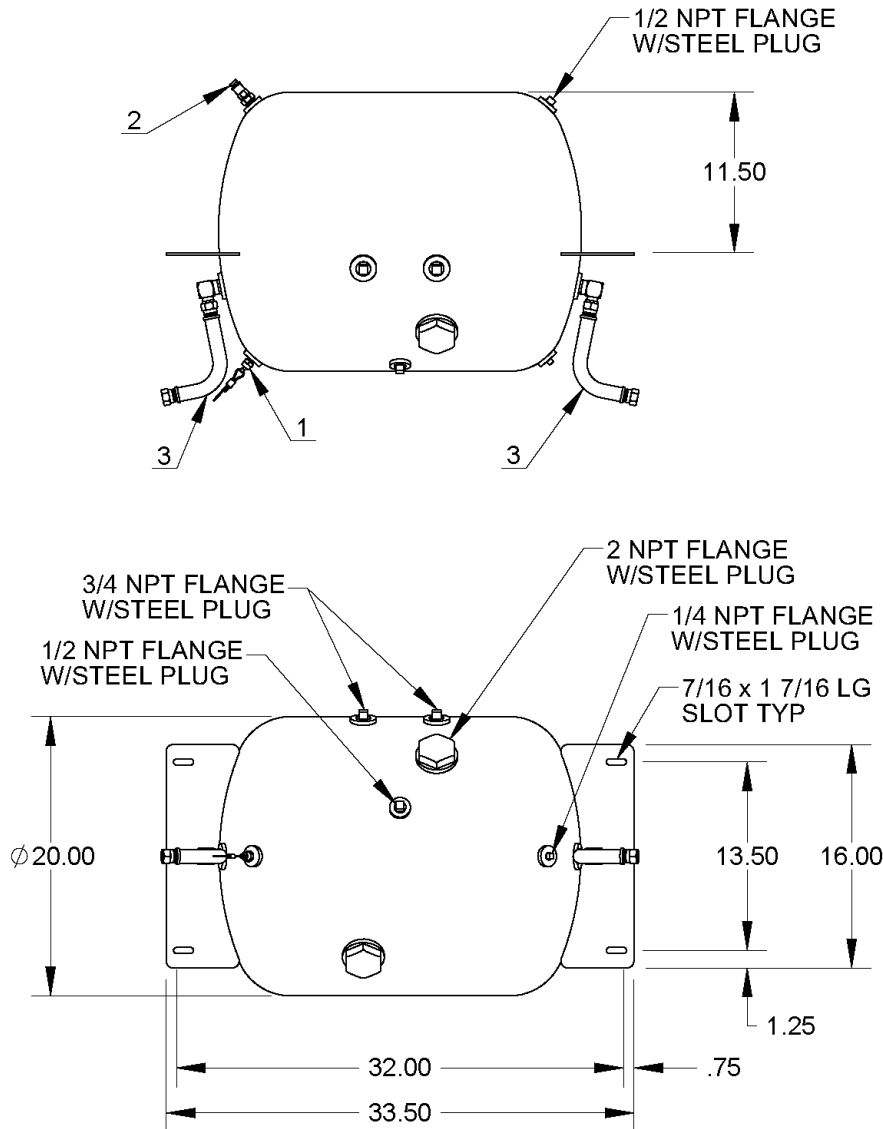

**REPLACEMENT PARTS INCLUDE:**

ITEM NO.	QTY	PART NUMBER	DESCRIPTION
1	1	751089000	VALVE, 1/4 NPT DRAIN W/ 60" CABLE
2	1	751220100	VALVE, RELIEF, 200 PSI, 1/4 NPT, ALUM
3	360 in.	750209000	HOSE, 5/8

# **FIRE EXTINGUISHER**

## **TITAN SERIES - P/N: 750061000**

### **TYPE:**

5LB/LEVER SQUEEZE/HOSE & HOSE/PRESSURE GAUGE  
PER NATIONAL FIRE PROTECTION ASSOCIATION STD. NO.10  
"PORTABLE FIRE EXTINGUISHERS

### **SPECIFICATIONS:**

- (A) UNDERWRITERS LABORATORIES (UL LISTED)
- (B) DRY CHEMICALS FIRE EXTINGUISHERS CLASSIFICATION  
2-A: 10-B-C. TESTED TO ANSI/UL 711 & ANSI/UL299.
- (C) 5 LB (2.27 KG) MULTI-PURPOSE DRY CHEMICAL  
(AMMONIUM PHOSPHATE BASE)
- (D) SUITABLE FOR USE AT TEMPERATURE FROM  
-65° F TO 120° F (54° C TO 49° C)

### **NOTE:**

EXTINGUISHER TO COME WITH OWNERS MANUAL FOR HAND PORTABLE FIRE EXTINGUISHERS.

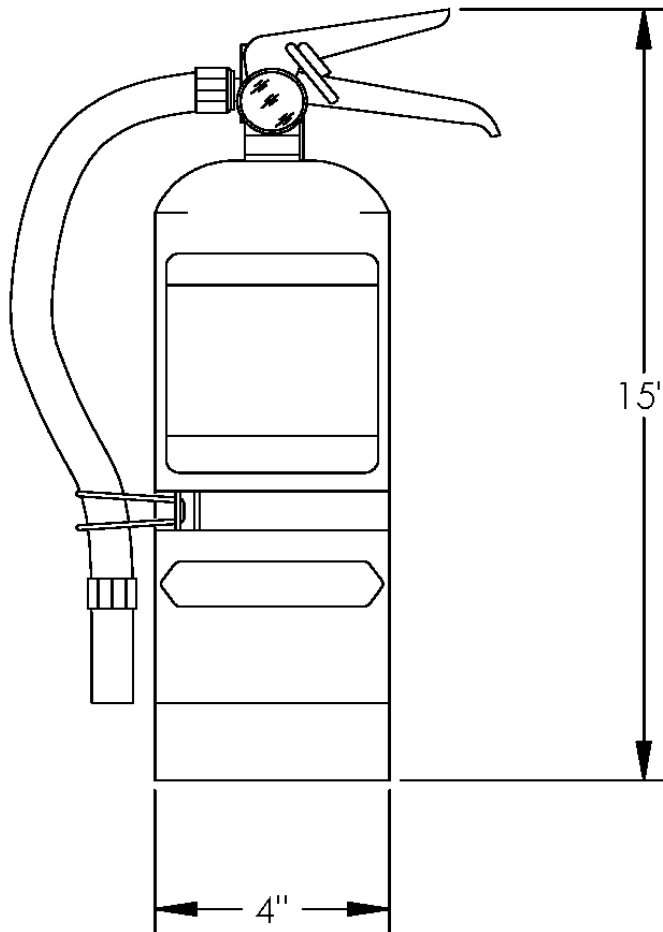

# **BACK-UP ALARM**

## **TITAN SERIES - P/N:750681000**

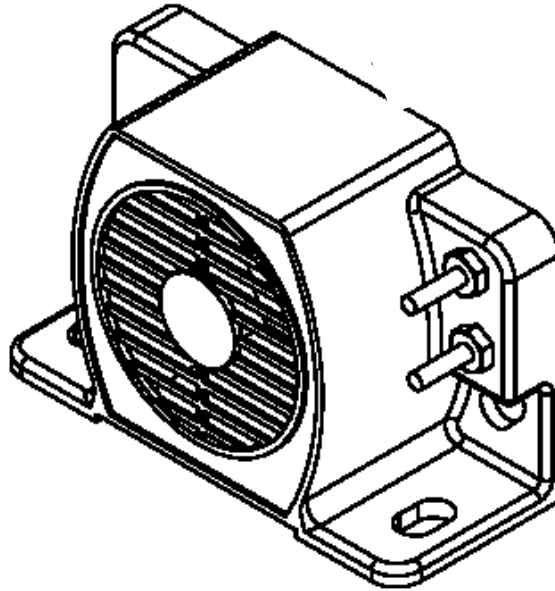

### **DESCRIPTION**

BACK-UP SAFETY ALARM MEETS OR EXCEEDS SAE J99 4B

VOLUME: 102 Db  
VOLTAGE: 12/24 VDC  
PULSE RATE: 90/MINUTE

POWER CONNECTION: 2-18", 16 GA. LEADS; RED LEAD TO POSIVE;  
BLACK LEAD TO GROUND.

### **MOUNTING INSTRUCTIONS**

1. DRILL TWO HOLES FOR 1/4" BOLTS 3 1/4 BETWEEN CENTERS.
2. MOUNT ALARM TO VEHICLE OR BRACKET
3. UNIT MAY BE CONNECTED DIRECTLY INTO THE BACK-UP LIGHT CIRCUIT, IF NOT AVAILABLE, MOUNT A SWITCH SUCH THAT IT OPERATES WHEN THE VEHICLE IS PLACED IN REVERSE. APPLY VOLTAGE 12 THRU 24 VDC VIA SWITCH TO THE RED LEAD, CONNECT THE BLACK LEAD TO GROUND. ALARM WILL SOUND EACH TIME WHEN VEHICLE IS PLACED IN REVERSE.

# BODY PREVENTIVE MAINTENANCE TITAN SERIES

## PREVENTIVE MAINTENANCE RECOMMENDATIONS FOR EXTERIOR SURFACES ON TRUCK SERVICE BODIES

### PAINT FINISH PREVENTIVE MAINTENANCE INSTRUCTIONS

The paint finish on Auto Crane products can become damaged during normal use when chipped, scratched, exposed to harsh chemicals, cleaned with high pressure washers, etc. During periods when the truck is exposed to salt or other corrosive chemicals, the truck should be washed weekly. The paint finish should be inspected when washed or at least monthly. Any exposed bare metal or visible rust should be repaired immediately. The repairs should be performed in the damaged area by following steps 1-5 in the TOP COAT PAINT PREPARATION INSTRUCTIONS section.

### TOP COAT PAINT PREPARATION INSTRUCTIONS

The following paint process steps should be used by Auto Crane distributors when top coating bodies that were primed by Auto Crane: **(Note: Unbolt doors from body and paint separately per the instructions shown below)**

1. Clean all surfaces to be top coated so dirt, oil, and other contaminants do not get embedded in the primer when sanded.
  - a. Wash with a mild detergent in warm water.
  - b. Rinse with clean water.
  - c. Wipe dry with a clean cloth.
2. Scuff sand all primed areas to be top coated with 320 grit sandpaper or an equivalent abrasive. Sand any areas with visible rust to bare metal.
3. Solvent clean all areas to be top coated to remove sanding residue. Wipe dry with a clean cloth to remove any remaining residue.
4. Re-prime the following areas to a minimum 2 mil dry film thickness per the primer manufacturer's instructions. The primer must be compatible with Sherwin Williams' E2W932 epoxy primer.
  - a. All bare metal.
  - b. All exposed corners and narrow edges, such as on doors, door openings, drip rails, and bumpers. This is necessary because excessive primer tends to get removed when sanding corners and narrow edges.
  - c. All areas to be top coated if the body has been stored in an outside environment for more than 3-6 months. This is necessary because more primer tends to get removed when sanding a primed-only body that has been exposed to the sun and outside environment for an extended period.
5. Apply a 2 mil dry film thickness top coat per the manufacturer's instructions within 24 hours of completing steps 1-4. The top coat paint must be compatible with Sherwin-Williams' E2W932 epoxy primer. The final primer and top coat should have approximately a 4 mil dry film thickness. Allow paint to fully cure before delivery to customer.



P.O. Box 580697 \* Tulsa, OK 74158-0697  
4707 N. Mingo Rd. \* Phone (918) 836-0463

## LIMITED WARRANTY 2 YEAR PARTS AND LABOR

Auto Crane will warranty to the consumer for a period of (2) years parts and labor from the date of purchase. Each new Auto Crane unit they sell will be free under normal use and service from defects in material and workmanship. Date of purchase will be honored as the date indicated on the Bill of Sale, which must accompany the Warranty Registration and be on file with Auto Crane. Absent a valid Warranty Registration and appropriate documentation, the original date of manufacture, as indicated by the serial number on the product, will be used to determine the effective date of the 2 year warranty.

The obligation of Auto Crane under this warranty is limited to the replacement or repair of parts that appear to the manufacturer after review and/or inspection to be defective and paid flat rate labor for replacing defective parts. This warranty does not obligate Auto Crane to bear the travel time charges in connection with the replacement or repair of defective parts. Responsibility for customer's claims arising from misapplication, abuse, misuse or alteration of equipment or parts lies with the distributor or user and no warranty obligation is assumed in these circumstances by Auto Crane.

Auto Crane will in no event be liable for any consequential damages or contingent liabilities arising out of the failure of any Auto Crane Product or parts to operate properly.

Auto Crane makes no warranty in respect to component accessories, it being subject to the warranties of their respective manufacturers.

If field service, at the request of the distributor, is rendered and fault is found not to be with Auto Crane's product, the distributor shall pay the time and expense of the field representative.

Claims for service labor or other expenses that have incurred by the buyer without approval or authorization or Auto Crane will not be accepted.

When applying for warranty, claims may be handled by contacting your nearest authorized Auto Crane **Distributor**. **All claims are to be filed in writing on an Auto Crane Warranty Claim Form.**

**AUTO CRANE COMPANY IS UNDER NO OBLIGATION TO EXTEND THIS WARRANTY TO ANY CUSTOMER FOR WHICH AN AUTO CRANE DELIVERY REPORT FORM HAS NOT BEEN COMPLETED AND ON FILE WITH AUTO CRANE COMPANY**



P.O. Box 580697 \* Tulsa, OK 74158-0697  
4707 N. Mingo Rd. \* Phone (918) 836-0463

## 5 YEAR LIMITED BODY WARRANTY

### COVERED PRODUCTS:

- \* Auto Crane Service Bodies - no rust-thru guarantee to the first owner/user of record for five (5) years from the date of purchase.
- \* Door Hinges - Guarantee the hinges will not fail to operate or come off the product, to the first owner/user of record for five (5) years from the date of purchase.

### ELIGIBILITY:

- \* Product(s) warranted must be properly maintained and serviced.
- \* The selling distributor must file for the first owner/user the application for warranty by completing the delivery report form enclosed in the Owners Manual within 30 days of the product purchase date. The complete delivery report form must be forwarded to Auto Crane Company. The warranty agreement issued is not transferable.

### EXCLUSIONS:

- \* Warranty applies to the Auto Crane bodies only and excludes all options, modifications and alterations.
- \* Paint required following repairs or replacement of parts under warranty after the first year from the date of delivery.
- \* Product(s) that have been misused or damaged, inclusive of, but not limited to, accidents.
- \* Absent a completed and valid delivery report form, the original date of manufacture will be used as the effective date for the limited warranty.

### SPECIFIC NON-RUST-THRU WARRANTY EXCLUSIONS:

- \* Product(s) that have been used to carry corrosive materials, where such materials result in rust-thru conditions.
- \* Product(s) purchased by the first owner/user in prime paint condition.
- \* Consequential damages including, but not limited to, transportation costs, lost profit and loss of income, as a result of a vehicle being out of service.
- \* Product(s) purchased and used outside the U.S.A. or Canada.

### APPLYING FOR WARRANTY:

- \* Claims may be handled by contacting your nearest authorized Auto Crane Distributor. All claims are to be filed in writing on an Auto Crane Warranty Claim Form.
- \* The Auto Crane Company reserves the sole right to inspect item(s) claimed for warranty and decide the best way to handle any and all claims, including the replacement or repair of the warranted part.
- \* Should the warranted product rust thru, the hinges fail to operate or come off the product, Auto Crane will pay the cost of parts and flat rate labor to repair or replace as necessary the defective component. NOTE: Paint following repair or replacement of a part is exclusive under warranty after the first year from date of delivery.
- \* DEFECTS FROM MANUFACTURING WORKMANSHIP AND/OR MATERIAL NOT SPECIFIED ABOVE WILL BE SUBJECT TO WARRANTY INCLUSIVE OF MATERIALS AND LABOR TO THE FIRST OWNER/USER OF RECORD FOR TWO (2) YEARS FROM THE DATE OF DELIVERY. Exclusions, as well as methods of applying for warranty remain the same as stated in the limited five (5) year warranty covered above.



P.O. Box 580697 \* Tulsa, OK 74158-0697  
4707 N. Mingo Rd. \* Phone (918) 438-2760

## LIMITED WARRANTY 1 YEAR PURCHASED REPLACEMENT PARTS

Auto Crane will warranty to the consumer for a period of (1) year from the date that a new Auto Crane replacement part was purchased from an authorized Auto Crane distributor. Each new Auto Crane part they sell will be free under normal use and service from defects in material and workmanship. Date of purchase will be honored as the date indicated on the Bill of Sale to the consumer.

The obligation of Auto Crane under this warranty does not apply to parts replaced under the limited warranty for a new Auto Crane product. The warranty for parts replaced under the limited warranty of a new Auto Crane product expires when the warranty for that product expires.

The obligation of Auto Crane under this warranty is limited to the replacement or repair of purchased replacement parts that appear to the manufacturer to be defective after review of documentation (Auto Crane Warranty Claim Form, photos, data, etc.) provided by the Auto Crane distributor and/or inspection of parts returned to Auto Crane. This warranty does not obligate Auto Crane to bear labor costs to replace the defective parts or travel time charges in connection with the replacement or repair of defective parts. Responsibility for customer's claims arising from misapplication, abuse, misuse or alteration of equipment or parts lies with the distributor or user and no warranty obligation is assumed in these circumstances by Auto Crane.

Auto Crane will in no event be liable for any consequential damages or contingent liabilities arising out of the failure of any Auto Crane product or parts to operate properly.

Auto Crane makes no warranty in respect to parts for component accessories, it being subject to the warranties of their respective manufacturers.

If field service, at the request of the distributor, is rendered and fault is found not to be with Auto Crane's product, the distributor shall pay the time and expense of the field representative.

Claims for service labor or other expenses that have incurred by the buyer without approval or authorization or Auto Crane will not be accepted.

When applying for warranty, claims may be handled by contacting your nearest authorized Auto Crane **Distributor**. **All claims are to be filed in writing on an Auto Crane Warranty Claim Form.**





