

REVISIONS				
ECN#	REV.	DESCRIPTION	DATE	BY
700706	A	PRODUCTION RELEASE	1/29/21	MJL

MOUNTING INSTALLATION:

1. INSTALL RIVET AND JACKNUT INTO HOLES SHOWN IN VIEW. WRENCH (366823467) MAY BE REQUIRED TO HOLD 366823462.
2. ATTACH CRADLE SUPPLIED WITH CRANE USING THE HARDWARE PROVIDED.
3. ATTACH RELAYS TO LIGHT COVER USING THE HARDWARE PROVIDED.
4. ATTACH HARNESS TO RELAYS AND CRADLE (REF PAGE 2)
5. RUN CABLE TO CAB AND ATTACH TO CHIME, GROUND, AND POWER FEEDS (REF. PAGE 2)
6. MOUNT CHIME IN CAB. GROUND "-" POST TO GROUND LOCATION
7. TEST FOR PROPER OPERATION. THE CHIME SHOULD ONLY SOUND WHEN THE TRANSMITTER IS OUT OF THE CRADLE, CRANE POWER IS OFF, AND IGNITION IS ON.

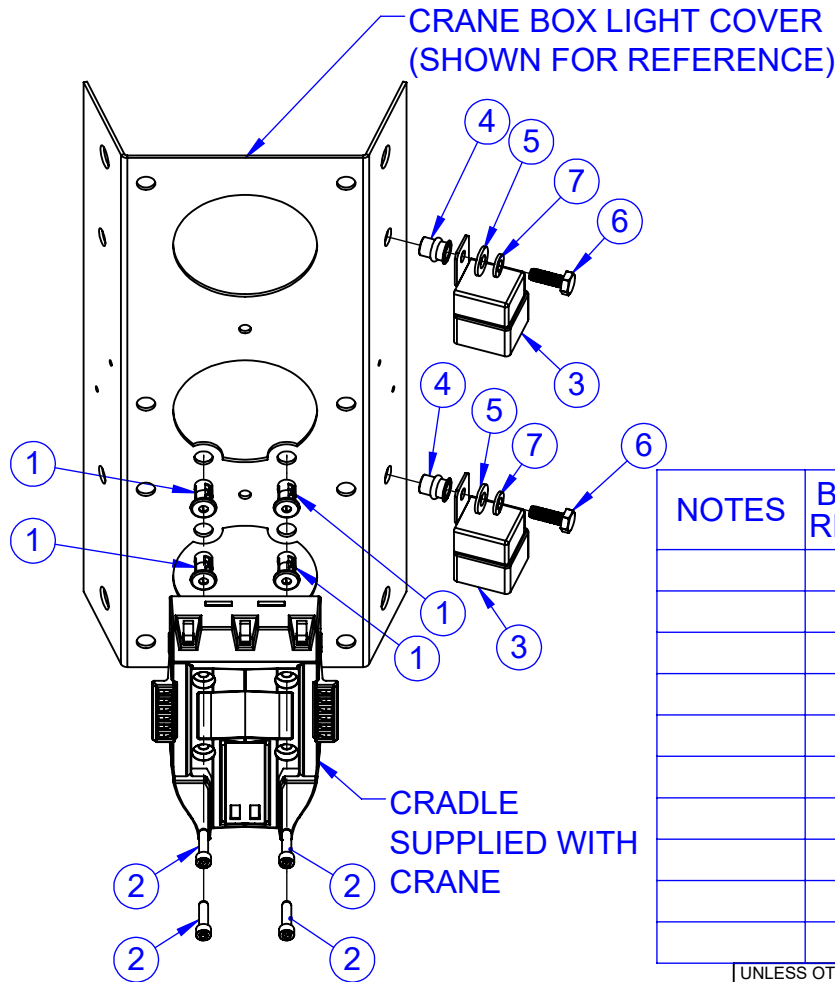

NOTES	BOM REVS	ITEM NO.	QTY	PART NUMBER	DESCRIPTION
		1	4	366823462	RIVET, #10-24 JACKNUT
		2	4	460094001	SCREW, SOC HD, #10-24 X 3/4"L, ZPL
		3	2	320355	RELAY, BOSCH
		4	2	736272	NUTSERT 1/4-20UNC X .027-.165 GRIP
		5	2	020400	WASHER FL SAE 1/4
		6	2	005500000	SCREW HX HD 1/4UNC X 3/4 GR5
		7	2	020200	WASHER SP LK 1/4
		8	1	366823467	HARNESS, CRADLE NS IV
		9	1	366823463	WRENCH, #10 JACKNUT FRICTION
		10	1	739171106	CHIME, 12VDC 65-75dB, SCREW

UNLESS OTHERWISE NOTED
ALL DIMENSIONS ARE IN INCHES.

TOLERANCES UNLESS OTHERWISE SPECIFIED.
 ANGLES $\pm 1/2^\circ$.X $\pm .060$
 FRACTIONAL $\pm 1/16$.XX $\pm .030$
 .XXX $\pm .010$

REMOVE ALL BURRS AND SHARP EDGES. DO NOT SCALE THIS DRAWING.
 TOLERANCES NOT SHOWN ABOVE ARE PER ANSI Y14.5-1973

THIS PRINT IS THE PROPERTY OF AUTO CRANE CO. AND MUST NOT BE USED IN ANY MANNER DETRIMENTAL TO THEIR INTERESTS.



4707 NORTH MINGO ROAD
 P.O. BOX 580697
 TULSA, OKLAHOMA 74158-0697
 918-836-0463

TITLE				
CRADLE, INSTALLATION NS IV				
DRAWN BY	DATE	SIZE	DRAWING NO.	REV
ML	1/29/21	A	366823465	A
SCALE: DO NOT SCALE DRAWING			WEIGHT	SHEET
				1 OF 2

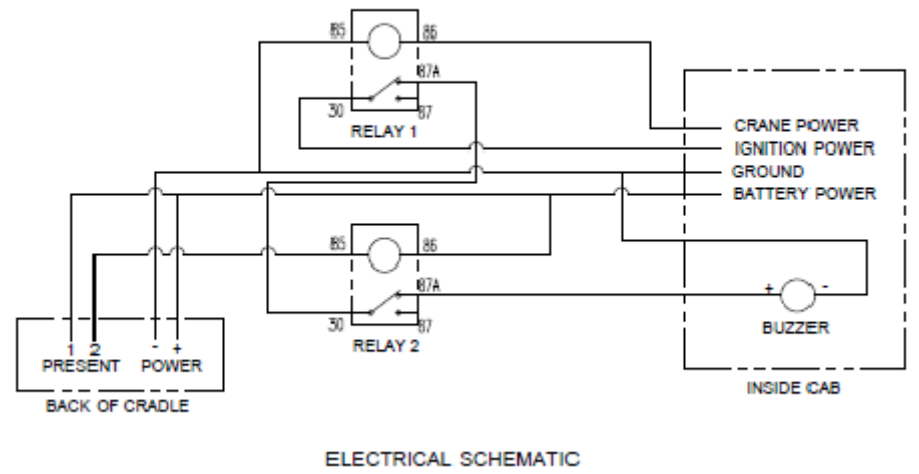
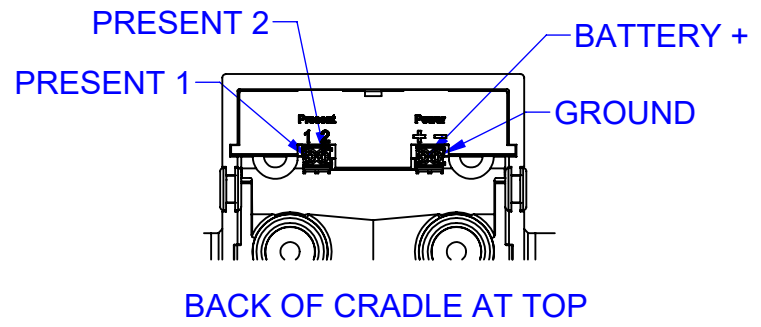
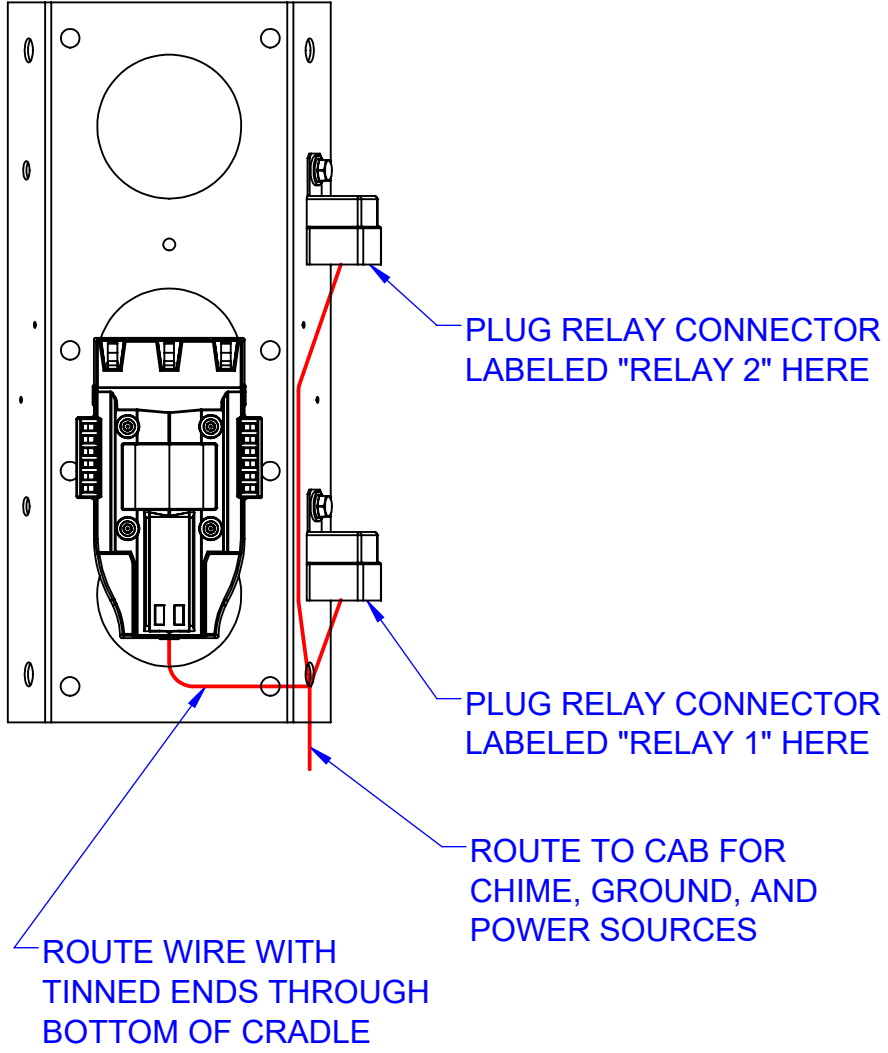

	TITLE CRADLE, INSTALLATION NS IV				
	DRAWN BY ML	DATE 1/29/21	SIZE A	DRAWING NO. 366823465	REV A
<small>THIS PRINT IS THE PROPERTY OF AUTO CRANE CO. AND MUST NOT BE USED IN ANY MANNER DETRIMENTAL TO THEIR INTERESTS.</small>	SCALE: DO NOT SCALE DRAWING	WEIGHT	SHEET 2 OF 2		

PRINTED ON: Monday, February 1, 2021